

DRAWING MADE IN THIRD ANGLE PROJECTION

PART NUMBER	REV	FIRST USED	MACHINE REFERENCE	FEED TYPE
566400-1	B	356462-2	G-SPLICE TERM	AIR FEED
566400-2	D	2161300-1	5K CE & GI THRU SPLICE	AIR FEED
7-566400-7	B	356462-2	SPARE PARTS KIT	-
7-566400-8	D	-	CONV. KIT FOR -1 TO -2	-

566400 566400

TERMINAL NAME: AMPLIVAR™ THRU SPLICE		CRIMPING DATA			
REF PAD LTR	62311-2	CRIMP HEIGHT	MAG WIRE STRANDED WIRE		
		5 .117 ±.002 [2.97 ±0.05mm]	11MAG + 14AWG		
CRIMP	SIZE	TYPE	RANGE		
WIRE	.250 [6.35mm]	F	11MAG + 14AWG		
INSUL	.250 [6.35mm]	OV	.160 MAX		
WIRE STRIP LENGTH	TERM APPL SPEC	FEED	APPL INSTRUCTION	SET UP GAGE	LAYOUT
.279-.341	114-2009	.430	408-8318 (-1) 408-127000 (-2)	-	-

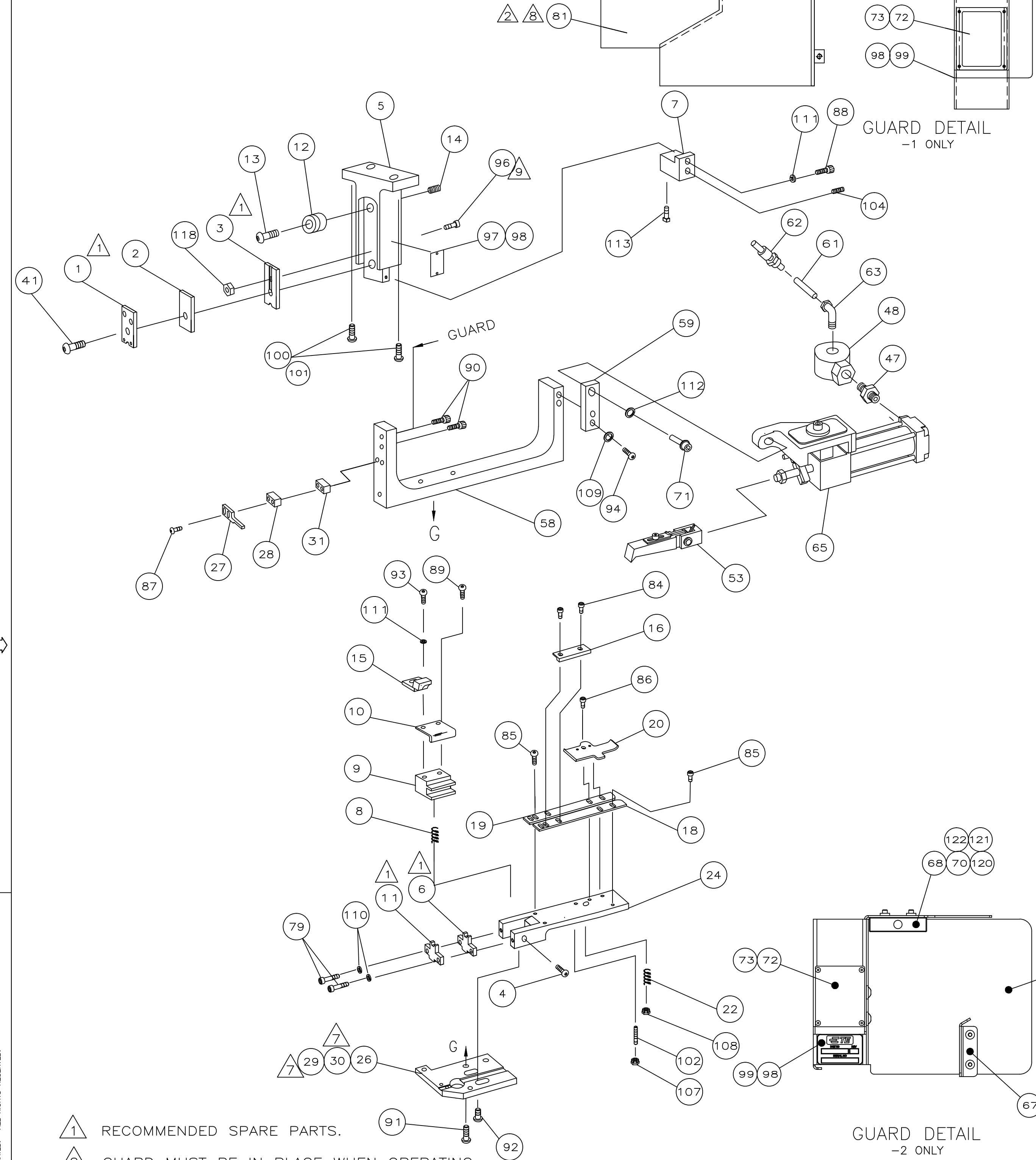

2	-	2	-	-	18029-2	M4 HEX NUT	123	
2	-	2	-	-	18025-2	M4 LOCK WASHER	121	
2	-	2	-	-	18027-2	M4 FLAT WASHER	120	
1	-	1	-	-	408-32162	THRU SPLICE IS SHEET-GII	119	
-	-	1	1	-	21018-5	NUT, HEX (6-32) CRIMPER	118	
-	-	2	2	-	21055-6	WASHER, FLAT (#6)	117	
-	-	1	-	-	408-127000	THRU SPLICE IS SHEET	116	
-	-	1	1	-	217238-1	GENERAL INSTRUCTION PACKAGE	115	
-	-	-	1	-	408-8318	THRU SPLICE IS SHEET	114	
-	-	1	1	-	1424328-2	SQUARE HD SCR	113	
-	-	1	1	-	21024-8	WASHER, LOCK (3/8)	112	
-	-	2	2	-	21024-3	WASHER,LOCK(NO.6)STR & SHR	111	
-	-	2	2	-	21024-4	WASHER,LOCK(NO.8)SHEAR BL	110	
-	-	2	2	-	21024-5	WASHER,LOCK(NO.10)	109	
-	-	1	1	-	21022-4	NUT,HEX SELF LKG(1/4-20)	108	
-	-	2	2	-	21018-6	NUT,HEX(8-32)DRAG	107	
-	-	-	-	-	-	-	106	
-	-	-	-	-	-	-	105	
-	-	1	1	-	22736-3	SCR,SKT,SET NYLON (6-32x.156)	104	
-	-	-	-	-	-	-	103	
-	-	2	2	-	5-21061-5	SCR,SKT,SET CONE PT (8-32x.88)	102	
2	-	2	-	-	3-18023-3	SCR, SHC (M6x50)	101	
-	-	-	2	-	3-18023-1	SCR, SHC (M6x30)	100	
-	-	1	1	-	461264-1	PLATE, IDENTIFICATION	99	
-	-	2.00	2.00	-	25527-6	TAPE, POLYURETHANE	98	
-	-	1	1	-	690701-2	PLATE, IDENTIFICATION	97	
-	-	1	1	-	2-21000-1	SCR, SHC 6-32 X .62 LG.	96	
-	-	-	-	-	-	-	95	
-	-	2	2	-	3-21000-5	SCR, SHC (10-32x.50)	94	
-	-	1	1	-	23030-3	SCR, SHC, SELF-LOCK 6-32x.50 LG.	93	
-	-	4	4	-	3-21002-3	SCR,BHC(1/4-20x.50)ST GD PL	92	
-	-	2	2	-	2-22733-8	SCR, SHC (1/4-20x.62) FEED BKT	91	
-	-	2	2	-	2-21002-5	SCR, BHC 10-32 X .25 LG.	90	
-	-	1	1	-	22733-3	SCR, BHC, SELF-LOCK 6-32x.25 LG.	89	
-	-	1	1	-	1-21000-9	SCR, SHC 6-32 X .38 LG.	88	
-	-	2	2	-	8-21002-9	SCR, BHC 8-32 X 1.00 LG.	87	
-	-	1	1	-	21001-8	SCR,SHC(1/4-20x1.25)DRAG & ARM	86	
-	-	4	4	-	1-21002-7	SCR, BHC 6-32 X .38 LG.	85	
-	-	2	2	-	2-21000-0	SCR, SHC 6-32 X .50 LG.	84	
-	-	-	-	-	-	-	83	
-	-	-	-	-	-	-	82	
-	-	-	1	-	1338307-2	GUARD,APPLICATOR FEED	81	
-	-	-	3	-	1-21100-8	SCR,BHC10-32UNCX.50LG.	80	
-	-	2	2	-	3-21000-1	SCR,SHC(8-32X.1.00)ANVIL	79	
-	-	-	-	-	-	-	78	
-	-	-	-	-	-	-	77	
-	-	-	1	-	1338320-2	GUARD, END FEED	76	
-	-	-	-	-	-	-	75	
-	-	-	-	-	-	-	74	
-	-	4	4	-	1-21000-0	SCR, BHC (2-56x.25) GUARD WINDOW	73	
-	-	1	1	-	1338174-1	WINDOW, GUARD	72	
-	-	1	1	-	3-21001-3	SCR, SHC (3/8-16x.75) FEED ASSY	71	
-78	-77	-2	-1	U/M	PART NO	DESCRIPTION	ITEM NO	
				REVISION OF EACH ASSY NO (WHEN BLANK, USE DWG REVISION)				
QTY REQD PER ASSY				PARTS LIST				

2	-	2	-	-	1-18023-3	SCR, SHC, M4X16	70	
2	-	2	-	-	18024-6	SCR, BHC, M4X8	69	
1	-	1	-	-	2168489-1	ACTUATOR, SPARE MCI	68	
1	-	1	-	-	2161273-1	GUARD, END FEED INSERT	67	
1	-	1	-	-	2161272-2	GUARD, END FEED	66	
-	-	1	1	-	460277-1	AIR FEED ASSY	65	
-	-	-	-	-	-	-	64	
-	-	1	1	-	980285-2	ELBOW, SWIVEL (1 1/8NPT-1/4T)	63	
-	-	1	1	-	23238-1	QUICK DISCONNECT	62	
-	-	21.00	21.00	IN	27319-4	TUBING, POLY-FLO Ø.25	61	
-	-	-	-	-	-	-	60	
-	-	1	1	-	1338207-1	BRACKET, FEED EXT	59	
-	-	1	1	-	1338208-1	BRACKET, FEED	58	
-	-	-	-	-	-	-	57	
-	-	-	-	-	-	-	56	
-	-	-	-	-	-	-	55	
-	-	-	-	-	-	-	54	
-	-	1	1	-	460680-1	FEED FINGER ASSY	53	
-	-	-	-	-	-	-	52	
-	-	-	-	-	-	-	51	
-	-	-	-	-	-	-	50	
-	-	-	-	-	-	-	49	
-	-	1	1	-	22374-7	VALVE, QUICK EXHAUST	48	
-	-	1	1	-	22304-1	NIPPLE, HEX 1/8 NPT	47	
-	-	-	-	-	-	-	46	
-	-	-	-	-	-	-	45	
-	-	-	-	-	-	-	44	
-	-	-	-	-	-	-	43	
-	-	-	-	-	-	-	42	
-	-	1	1	-	7-21002-9	BOLT, CRIMPER(5/16-24x1.00)	41	
-	-	-	-	-	-	-	40	
-	-	-	-	-	-	-	39	
-	-	-	-	-	-	-	38	
-	-	-	-	-	-	-	37	
-	-	-	-	-	-	-	36	
-	-	-	-	-	-	-	35	
-	-	-	-	-	-	-	34	
-	-	-	-	-	-	-	33	
-	-	-	-	-	-	-	32	
-	-	1	1	-	2-690451-2	SPACER	31	
-	-	2	2	-	18027-4	WASHER, FLAT M6	30	
-	-	2	2	-	2-18023-9	SCR,SHC M6 X 20	29	
-	-	1	1	-	690451-2	SPACER	28	
-	-	1	1	-	240639-2	STRIPPER	27	
-	-	1	1	-	1424318-1	PLATE, BASE	26	
-	-	-	-	-	-	-	25	
-	-	1	1	-	458412-3	PLATE, STRIP GUIDE	24	
-	-	-	-	-	-	-	23	
-	-	1	1	-	3-22283-0	SPRING, DRAG	22	
-	-	-	-	-	-	-	21	
-	-	1	1	-	458403-1	DRAG, STOCK	20	
-	-	1	1	-	1-458406-1	GUIDE, STRIP (REAR)	19	
-	-	1	1	-	1-458404-2	GUIDE, STRIP (FRONT)	18	
-	-	-	-	-	-	-	17	
-	-	1	1	-	1424330-1	GUIDE, TERMINAL	16	
-	-	1	1	-	1424334-2	REAR STRIPPER	15	
-	-	1	1	-	27058-2	PLUNGER, SPRING, STUBBY	14	
-	-	1	1	-	21004-9	SCR, SHLD .31 DIA X .50 LG.	13	
-	-	1	1	-	1338124-1	WHEEL, ADJUSTING	12	
-	-	1	1	-	1424319-3	ANVIL	11	
-	-	1	1	-	1424335-5	SHEAR	10	
-	-	1	1	-	458409-8	HOLDER, SHEAR	9	
-	-	1	1	-	6-22282-8	SPRING, SHEAR RETURN	8	
-	-	1	1	-	1424322-2	BLOCK, SHEAR DEPRESSOR	7	
-	-	1	1	-	1424319-4	ANVIL, INSULATION	6	
-	-	1	1	-	1338212-2	HOLDER, TOOL	5	
-	-	1	1	-	690461-4	SCREW, SHEAR STOP	4	
-	-	1	1	-	1424326-1	CRIMPER, INSULATION	3	
-	-	1	1	-	2-455888-2	SPACER	2	
-	-	1	1	-	1338223-4	CRIMPER, WIRE, MODIFIED	1	
-78	-77	-2	-1	U/M	PART NO	DESCRIPTION	ITEM NO	
				REVISION OF EACH ASSY NO (WHEN BLANK, USE DWG REVISION)				
QTY REQD PER ASSY				PARTS LIST				

- 1 RECOMMENDED SPARE PARTS.
- 2 GUARD MUST BE IN PLACE WHEN OPERATING APPLICATOR IN A BENCH MACHINE.
- 3 SEE DRAWING FOR COMPONENTS.
- 4 CRIMPER BOLT MUST BE LOOSENED TO CHANGE CRIMP HEIGHT ADJUSTING WHEEL. BE SURE TO SEAT THE CRIMPER AGAINST THE ADJUSTING WHEEL AND REALIGN THE TOOLING.
- 5 USE MANUAL PRECISION ADJUSTMENT LEVER ON G TERMINATOR TO ACHIEVE PROPER CRIMP HEIGHT.
- 6 SOLID WIRE ON BOTTOM
- 7 ITEM NOT SHOWN.
- 8 ITEM 81 IS ATTACHED TO THE G TERMINATOR GUARD DOOR WITH ITEM 80.
- 9 CUT TO LENGTH AT ASSEMBLY

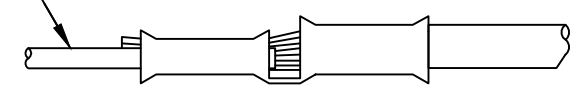

LOC A  
DIST 66

00493G

D

C

B

A

THIS DRAWING IS A CONTROLLED DOCUMENT.

MAY27,2001

RELEASED FOR PUBLICATION BY AMP INCORPORATED. ALL RIGHTS RESERVED.

THIS DRAWING IS UNPUBLISHED. © COPYRIGHT 2001