

■ Input-output condition

Item	Specification	Conditions · Note
Input voltage range	DC100V~420V	Average voltage
Maximum input voltage	420V or less	Including peak value
Input ripple voltage lower limit	75V or more	Ripple voltage of the AC input rectified
Rated input voltage	DC140V, DC340V	
Rated output voltage	12V	
Rated load current	3.4A	

■ Electrical specification Ta=25°C

Item	Specification	Conditions · Note
Efficiency	85% or more (90% TYP)	Rated input voltage Rated output current
Output voltage tolerance	±5%	
Line regulation	100mV or less	Input voltage DC100V~420V
Load regulation	250mV or less	Output current 0~3.4A
No-load power	50mW or less (25mW TYP)	Rated input voltage
Ripple	120mVp-p or less	Rated input voltage Rated output current
Ripple noise	150mVp-p or less	

Measurement circuit

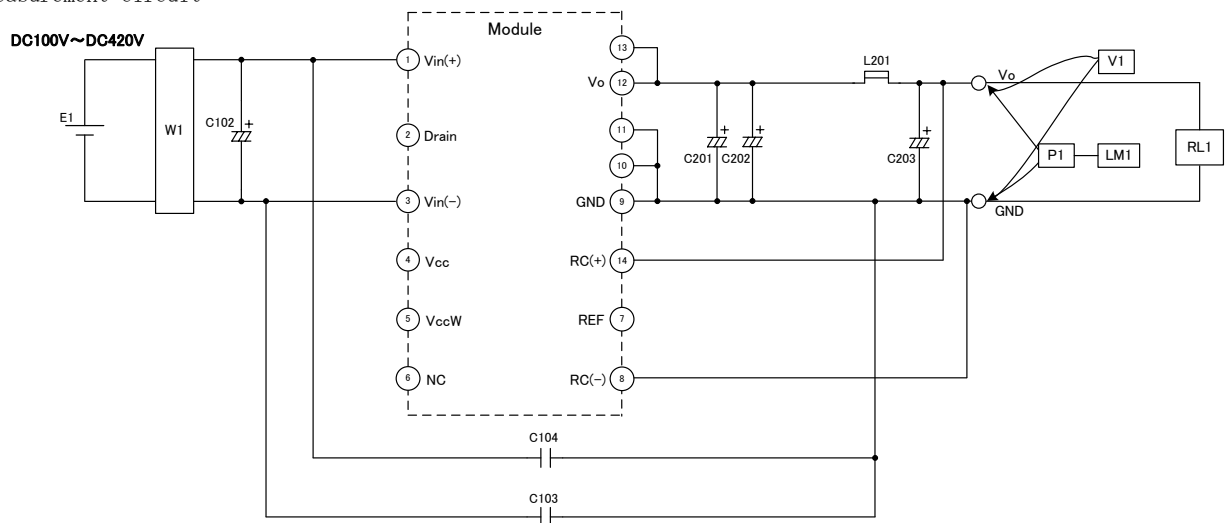

- E1 : DC power supply
- W1 : Wattmeter WT210 (YOKOGAWA)
- RL1 : Electronic load
- V1 : Voltmeter Class 0.5
- P1 : Differential probe DP-100 (KG)
- LM1 : Ripple noise meter RM-103 (KG)

- C102 : 450BXW100M (RUBYCON)
- C103 : CD75-B2GA331K (TDK)
- C104 : CD75-B2GA331K (TDK)
- C201 : 25ZLG1500M (RUBYCON)
- C202 : 25ZLG1500M (RUBYCON)
- C203 : 25ZLG820M (RUBYCON)
- L201 : PC8Z-2R2N (KORIN)

■Protection

Item	Specification	Conditions · Note
Overcurrent protection	5A or more	Auto recovery
Overvoltage protection	13.8V~18.5V	Latch off
Overheat protection		Latch off

■Insulation

Item	Specification	Conditions · Note
Insulation voltage (Between Pri-Sec)	3.0kV (or 3.6kV)	AC 1min (or AC 2sec) Cutoff 2mA
Insulation resistance (Between Pri-Sec)	100MΩ or more	DC500V

■Environmental conditions

Item	Specification	Conditions · Note
Operating temperature	-20°C~80°C	Refer to the Ambient temperature derating curve
Operating humidity	20~95%RH (No condensation)	
Storage temperature	-25°C~85°C	
Storage humidity	5~95%RH (No condensation)	

■Ambient temperature derating curve

Reduce the load current according to the following temperature derating table.

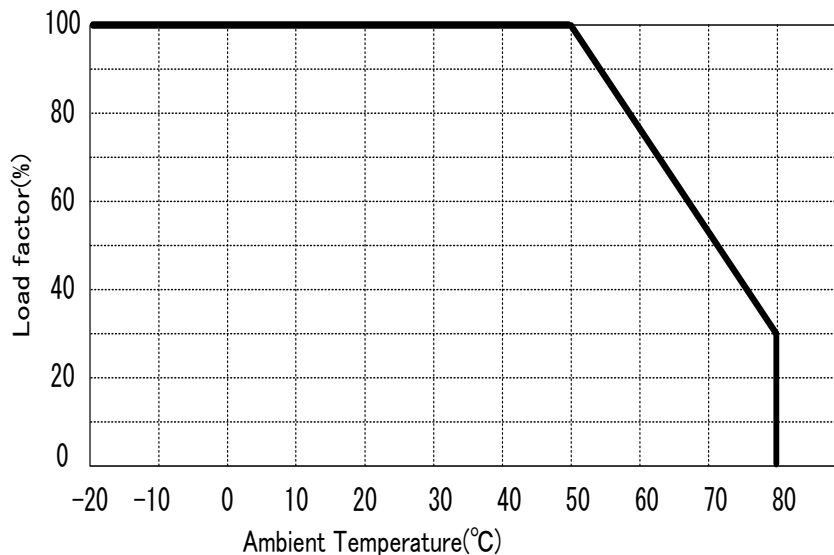

■ Typical characteristics Ta=25°C

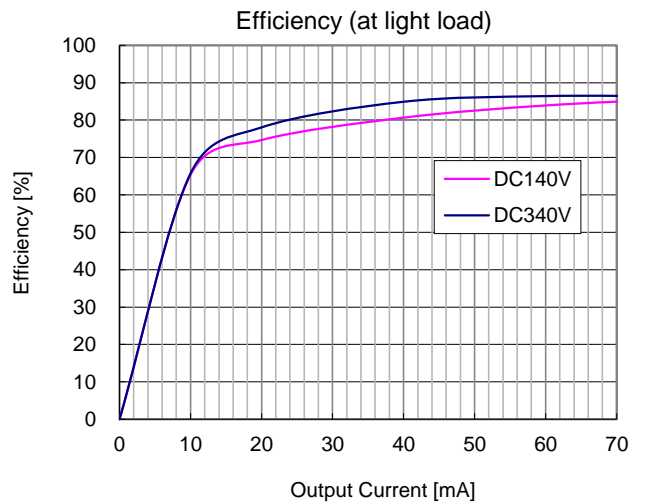
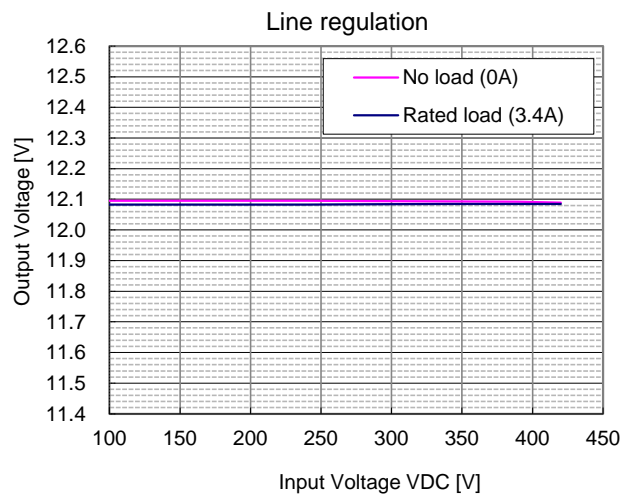
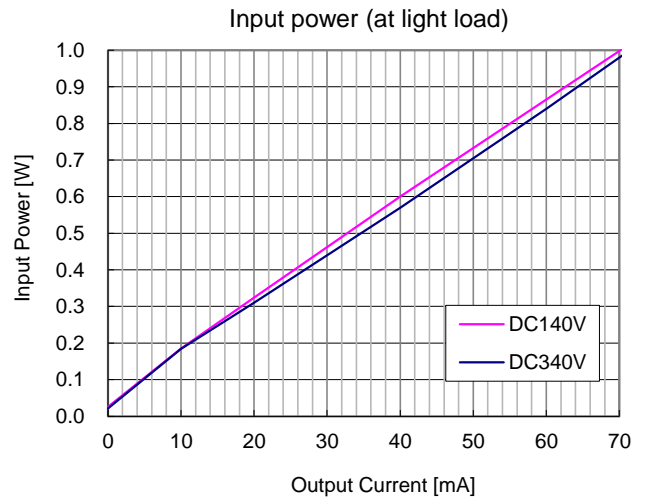
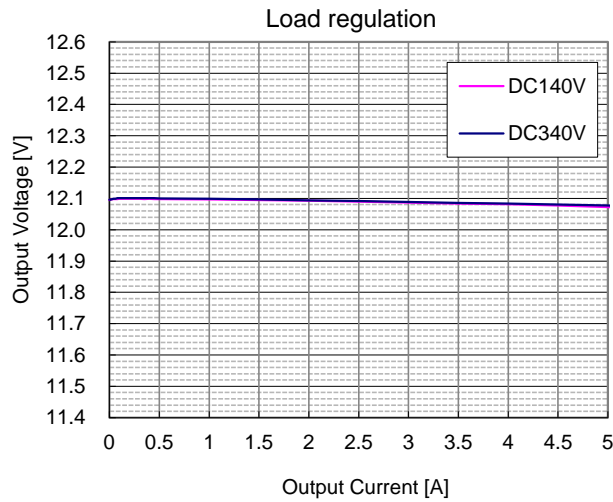
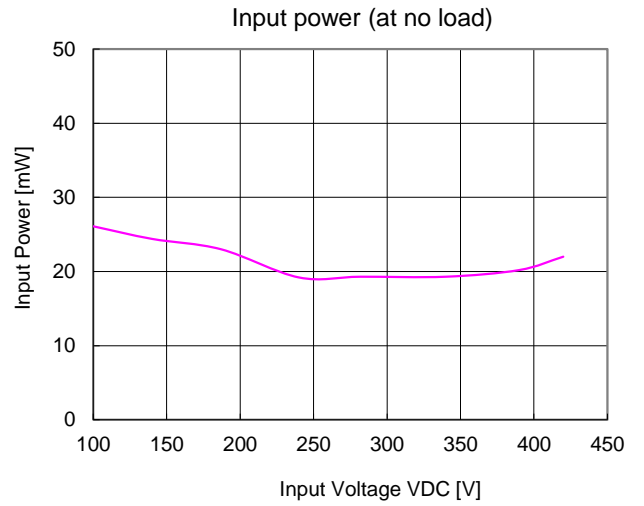
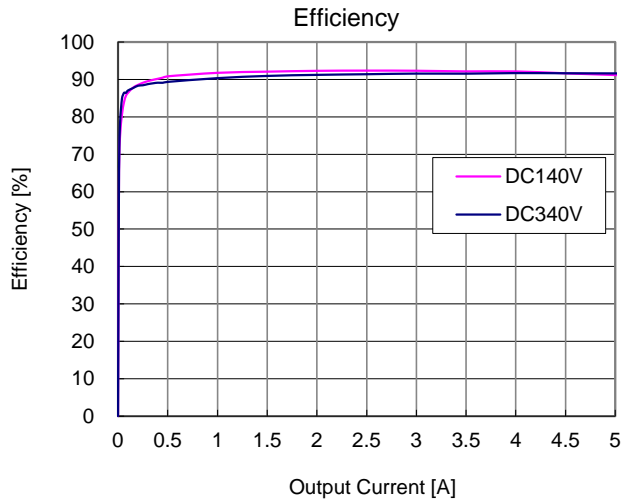

■Outline dimensional drawing

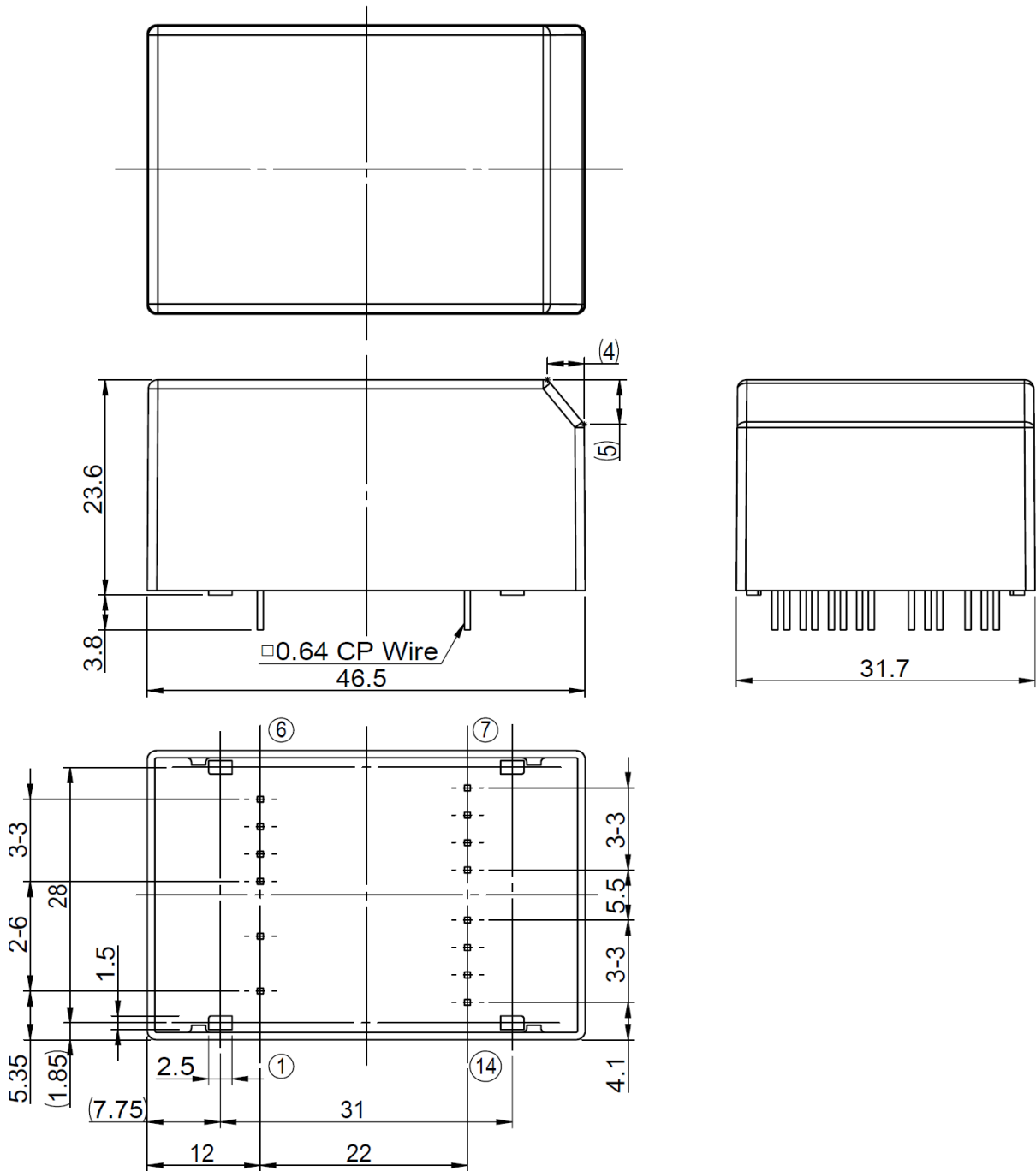

Note :1.The dimensional tolerance without directions is $\pm 0.5\text{mm}$.

Unit : mm

■Recommended hole diameter and land size

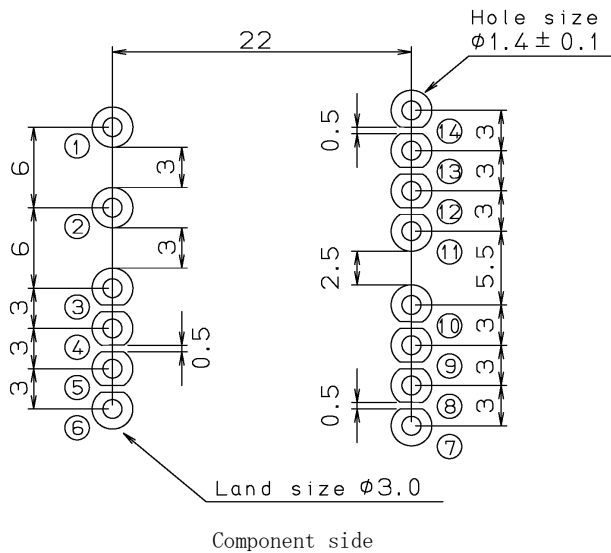

※ The round pulling out figure is a pin numbering.

Unit : mm

■Terminal function and connection

Primaries

Pin No.	Name	Explanation of terminals
1	Vin(+)	DC voltage input terminal (+)
2	Drain	Terminal for noise adjustment
3	Vin(-)	DC voltage input terminal (-)
4	Vcc	Terminal for start-up time adjustment
5	VccW	Auxiliary winding terminal ※Don't connect with other circuits.
6	N. C.	Unused terminal ※Don't connect with other circuits.

Secondaries

Pin No.	Name	Explanation of terminals
7	REF	Output voltage adjustment terminal
8	RC(-)	Output voltage detection terminal (-)
9	GND	Output terminal (-)
10	GND	Output terminal (-)
11	GND	Output terminal (-)
12	Vo	Output1 terminal (+)
13	Vo	Output1 terminal (+)
14	RC(+)	Output voltage detection terminal (+)

■Application circuit example
AC90V~AC264V
 (50/60Hz)

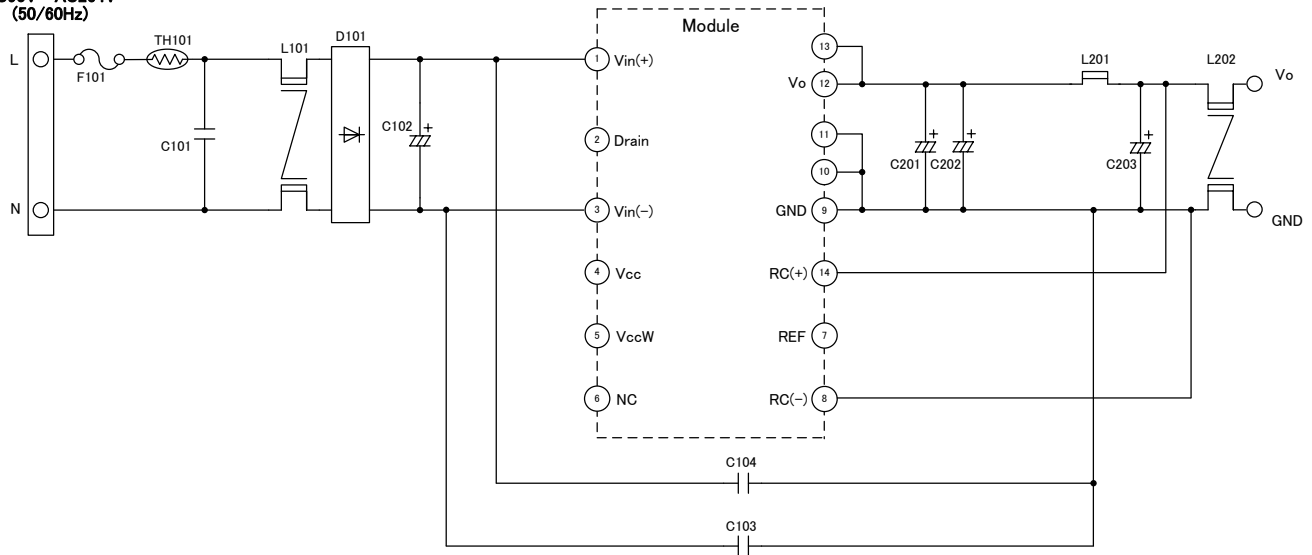

Symbol	Description	Part No.	Manufacturer
D101	Diode	D2SB60A	SHINDENGEN
L101	Inductor	HL-24R-E100THA	KORIN
L201	Inductor	PC8Z-2R2N	KORIN
L202	Inductor	0-5127-15-TM	KORIN
C101	Capacitor	LE104-MX	OKAYA
C102	Capacitor	400BXW100M	RUBYCON
C103	Capacitor	CD75-B2GA331K	TDK
C104	Capacitor	CD75-B2GA331K	TDK
C201	Capacitor	25ZLG1500M	RUBYCON
C202	Capacitor	25ZLG1500M	RUBYCON
C203	Capacitor	25ZLG820M	RUBYCON
F101	Fuse	FIH 250V 2.0A	NIPPON-SEISEN
TH101	Thermistor	SCK102R55AMIAY499	THINKING

※Mount the fuse on the input Live side to ensure safety without fail.
 Recommended parts : FIH 250V 2.0A~3.15A / NIPPON-SEISEN

※Depend on the applying safety standard, please add the discharge resistance in paralell with C101.