

Housing - HC-EVO-B24-HHFS-EL-AL - 1411473

Please be informed that the data shown in this PDF Document is generated from our Online Catalog. Please find the complete data in the user's documentation. Our General Terms of Use for Downloads are valid (<http://phoenixcontact.com/download>)



HEAVYCON EVO sleeve housing, EMC version, without powder coating, with bayonet flange for EVO screw connection, B24, for single locking latch, height: 88 mm, without EVO screw connection.

Your advantages

- Flexible cable outlet direction, lateral or straight



Key Commercial Data

Packing unit	1 pc
GTIN	 4 046356 932738
GTIN	4046356932738

Technical data

Dimensions

Height	88 mm
Width	44 mm
Length	120 mm

Ambient conditions

Degree of protection (IP)	IP66
	IP67
Degree of protection (NEMA)	4 (UL 50e)
	4X (UL 50e)
	12 (UL 50e)
Ambient temperature (operation)	-40 °C ... 125 °C

General

Note	For contact inserts HC-B24, BB46, D64, DD108, M
Size	B24

Housing - HC-EVO-B24-HHFS-EL-AL - 1411473

Technical data

General

Housing type	Sleeve housing
Color	gray aluminum
Locking type	for single locking latch
No. of cable outlets	1
Cable outlet	straight
	lateral
Screw connection	none
Housing material	Die-cast aluminum, salt water resistant
Housing surface material	uncoated
Connection	The sleeve base housing must be supplemented with the EVO screw connection. The EVO screw connection is available in 4 sizes. It enables the creation of a straight or a lateral cable outlet. The EVO screw connection is assembled by hand or using a pipe wrench.

Environmental Product Compliance

China RoHS	Environmentally friendly use period: unlimited = EFUP-e
	No hazardous substances above threshold values

Drawings

Dimensional drawing

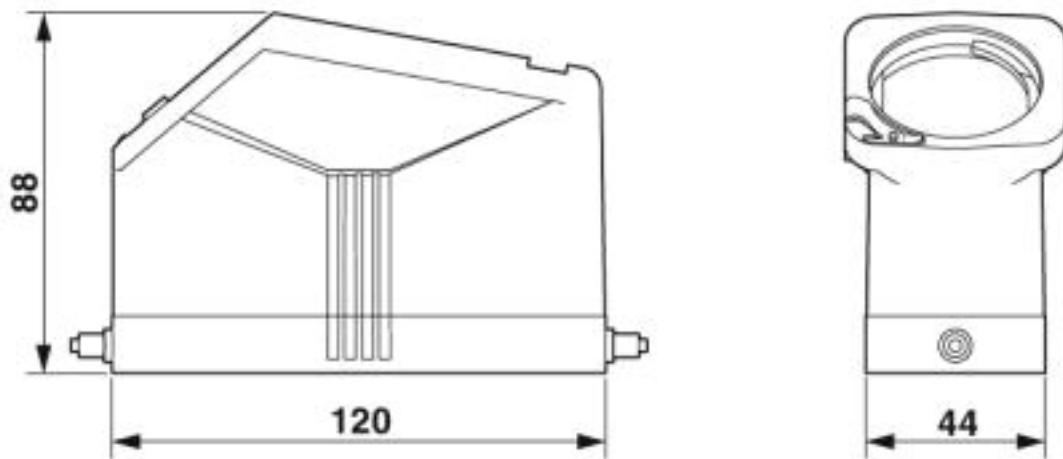

Dimensional drawing

Approvals

Approvals

Approvals

UL Recognized / cUL Recognized / EAC / DNV GL / cULus Recognized

Housing - HC-EVO-B24-HHFS-EL-AL - 1411473

Approvals

Ex Approvals

Approval details

UL Recognized		http://database.ul.com/cgi-bin/XYV/template/LISEXT/1FRAME/index.htm	E255026
cUL Recognized		http://database.ul.com/cgi-bin/XYV/template/LISEXT/1FRAME/index.htm	E255026
EAC			RU C- DE.AI30.B.01102
DNV GL		https://approvalfinder.dnvgl.com/	TAE000037S
cULus Recognized			

Phoenix Contact 2019 © - all rights reserved
<http://www.phoenixcontact.com>

PHOENIX CONTACT GmbH & Co. KG
Flachsmarktstr. 8
32825 Blomberg
Germany
Tel. +49 5235 300
Fax +49 5235 3 41200
<http://www.phoenixcontact.com>