

MATERIAL NUMBER	ENGINEERING NUMBER	TAPE MATERIAL NUMBER	TAPE ENGINEERING NUMBER	WIRE RANGE AWG MM ²	FITS MALE TAB SIZE	"L" MAX.	"B" ±.01/(±0.3)	"H" ±.01/(±0.3)
190160112	M-1133	190160097	M-1133T	26-24 0.1 -0.3	.110x.032 (2.80 X 0.81)	.53 (13.5)	.16 (4.1)	.08 (2.0)
190160037	BB-1135	190160038	BB-1135T	16-14 1.0-2.6	.110x.032 (2.80 X 0.81)	.57 (14.5)	.20 (5.1)	.08 (2.0)
190160075	M-1130	190160076	M-1130T	26-24 0.1 -0.3	.110x.020 (2.80 X 0.51)	.53 (13.5)	.16 (4.1)	.07 (1.8)
190160035	BB-1132	190160036	BB-1132T	16-14 1.0-2.6	.110x.020 (2.80 X 0.51)	.57 (14.5)	.20 (5.1)	.07 (1.8)

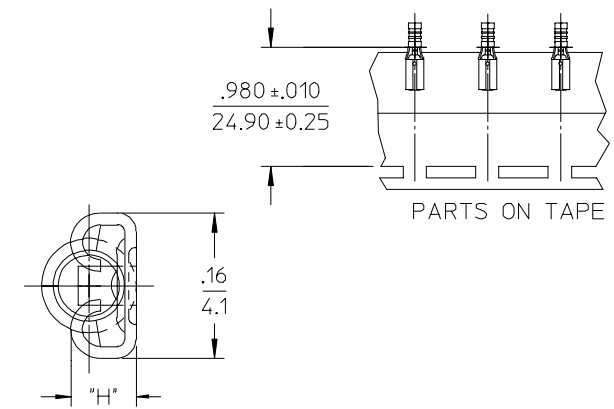
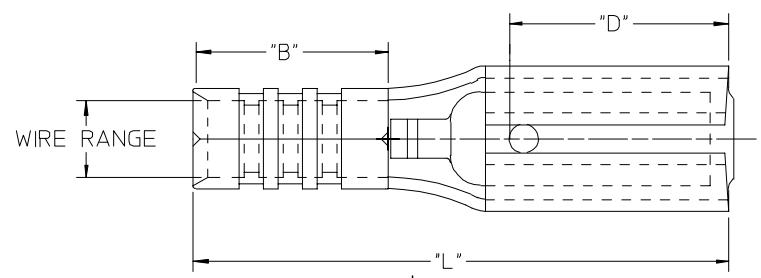

PARTS ON TAPE

NOTES:
 1. MATERIAL: BRASS .012 (.30) THK.
 FINISH: ELECTRO-TIN PLATING

WAS: CD-1903 EC NO: ETC2005-0016 DRWN: BENDERLE 2004/07/29 CHKD: BENDERLE 2004/07/29 APPR: RDEROSS 2004/07/29	QUALITY SYMBOLS	GENERAL TOLERANCES (UNLESS SPECIFIED)		SCALE NONE	DESIGN UNITS INCH	THIRD ANGLE PROJECTION	REVISE ON CAD ONLY
	DESCRIPTION	4 PLACES ± ---	3 PLACES ± ---	DIMENSION STYLE IN/MM		TITLE	
REV	DESCRIPTION	2 PLACES ± ---	1 PLACE ± ---	DRAWN BY DATE BENDERLE 2004/07/26		KRIPTITE QUICK DISCONNECTS	
A	ANGULAR ± ---°	DRAFT WHERE APPLICABLE		CHECKED BY DATE R DEROSS 2004/07/26		MOLEX INCORPORATED	
	MUST REMAIN WITHIN DIMENSIONS			APPROVED BY DATE R DEROSS 2004/07/26		MATERIAL NO. SEE CHART	DOCUMENT NO. SD-19016-001
				THIS DRAWING CONTAINS INFORMATION THAT IS PROPRIETARY TO MOLEX INCORPORATED AND SHOULD NOT BE USED WITHOUT WRITTEN PERMISSION		SHEET NO. 1 OF 1	