

PART NUMBER	REV	FIRST USED
680021-1	A	854400-1
680021-2	A	565435-5

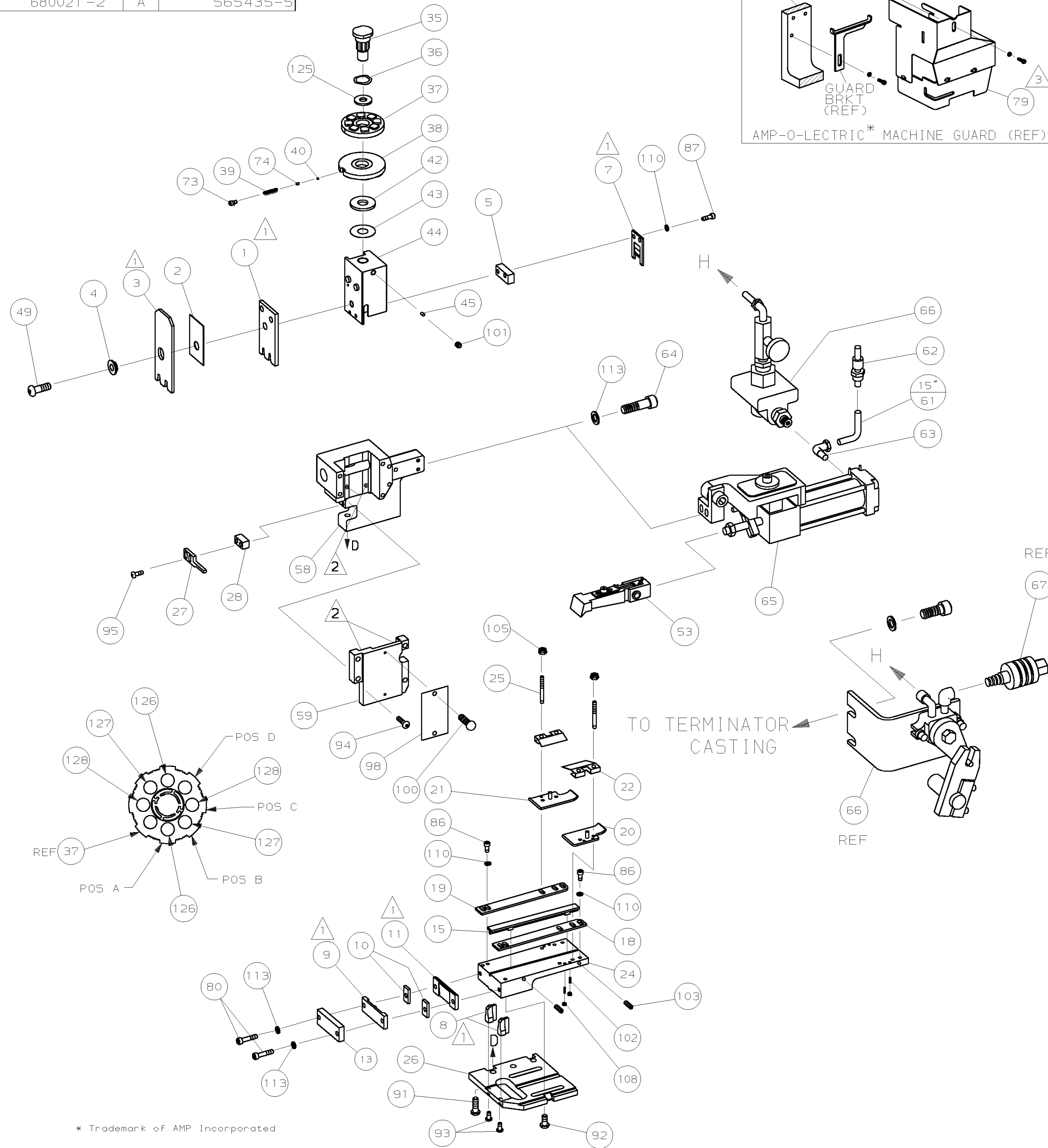
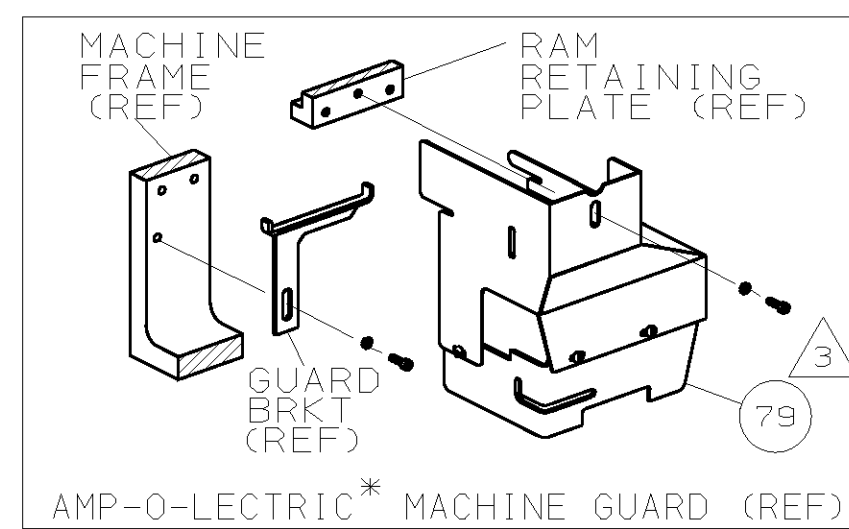

\* Trademark of AMP Incorporated

- 1 RECOMMENDED SPARE PARTS.
- 2 GREASE LIGHTLY.
- 3 GUARD MUST BE IN PLACE WHEN OPERATING APPLICATOR IN AMP-O-LECTRIC MACHINE.
- 4 SEE DRAWING FOR COMPONENTS

TERMINAL NAME: SPADE APPL BENDS TONGUE UP 45°		CRIMPING DATA	
	60390	PAD LTR	CRIMP HEIGHT
	60389	A	.069 ±.002
		B	.063 ±.002
		C	.059 ±.002
		D	NOT USED
		CRIMP	SIZE TYPE RANGE
		WIRE	.110 F 20-16
		INSUL	.155 0 .100-.140
		FEED	APPL INST SET UP GAGE LAYOUT
		.860	408-8046 455633-1 L1514
TERM APPL SPEC	114-2084	WIRE STRIP LENGTH	.173-.203

QTY	REV	U/M	PART NO	DESCRIPTION	ITEM NO	
2	2	-	C	354779-4	PIN, WIRE DISC (.3010)C	128
2	2	-	C	9-354778-5	PIN, WIRE DISC (.2970)B	127
2	2	-	C	8-354778-3	PIN, WIRE DISC (.2910)A	126
1	1	-	A	986950-1	WASHER, FLAT PRECISION	125
					124	
					123	
					122	
					121	
					120	
					119	
					118	
					117	
					116	
					115	
					114	
4	4	-	A	21024-5	WASHER, LOCK (NO.10) SHEAR PL	113
					112	
					111	
6	6	-	A	21024-4	WASHER, LOCK (NO.8) SHEAR BL	110
					109	
4	4	-	A	21018-6	NUT HEX (8-32) DRAG ADJ SCR	108
					107	
					106	
4	4	-	A	21022-2	NUT, HEX 5L (8-32) DRAG STUD	105
					104	
2	2	-	A	3-21006-1	SCR, SKT SET (6-32x.38) CTRSTR GUIDE	103
4	4	-	A	5-21061-5	SCR, SKT SET CONE PT (8-32x.88) DRAG	102
1	1	-	A	21009-2	SCR, SKT SET (1/4-20x.25 ) RAM	101
2	2	-	A	21017-2	SCR, DRIVE (#2x.19) ID PLATE	100
					99	
1	1	-	B	461264-1	PLATE, IDENTIFICATION	98
					97	
					96	
2	2	-	A	2-21002-3	SCR, BHC (8-32x.62) STRIPPER	95
4	4	-	A	3-21002-1	SCR, BHC (10-32x1.00) CAP	94
2	2	-	A	22733-8	SCR, BHC (8-32x.38 LW) ANVIL	93
4	4	-	A	3-21002-3	SCR, BHC (1/4-20x.50) ST 6D PL	92
3	3	-	A	2-22733-8	SCR, BHC (1/4-20x.62) H5G	91
					90	
					89	
					88	
2	2	-	A	2-21000-7	SCR, 5HC (8-32x.50) SLUG BLADE	87
4	4	-	A	7-21000-4	SCR, 5HC (8-32x.31) STRIP GUIDE	86
					85	
					84	
					83	
					82	
					81	
2	2	-	A	3-21000-9	SCR, SKT CAP (10-32x1.00) 5H PL	80
1	-	-	A	455750-6	GUARD ASSY	79
					78	
					77	
					76	
					75	
1	1	-	A	690603-1	SPRING, ASSIST	74
1	1	-	A	23030-1	SCR, SKT CAP (6-32x.25) CP DSC	73
					72	
					71	

QTY	REV	U/M	PART NO	DESCRIPTION	ITEM NO	
-1				LEADMAKER	AIRFEED	
-2				AMP-O-LECTRIC	AIRFEED	
					70	
					69	
					68	
REF	-	-	A	24042-2	VALVE, SHUT OFF	67
1	-	-	B	692655-5	VALVE ASSY	66
1	1	-	B	460277-3	AIR FEED ASSY	65
2	2	-	A	3-21000-7	SCR, 5HC (10-32x.75) AIR FD ASSY	64
-	1	-	A	22294-6	ELBOW, TUBING 1/8NPT - 1/4 T	63
-	1	-	A	23238-1	QUICK DISCONNECT	62
-	15.00	IN	A	27319-4	TUBING, POLY-FLO 1/4 DIA	61
					60	
1	1	-	C	458268-1	CAP, RAM	59
1	1	-	D	458267-1	HOUSING	58
					57	
					56	
					55	
					54	
1	1	-	B	460680-3	FEED FINGER ASSY	53
					52	
					51	
					50	
1	1	-	A	7-21002-9	BOLT, CRIMPER (5/16-24x1.00)	49
					48	
					47	
					46	
1	1	-	A	690191-1	PLUG, NYLON	45
1	1	-	C	458266-1	RAM	44
1	1	-	A	690125-1	WASHER, LAMINATED	43
1	1	-	A	690124-1	WASHER, RAM	42
					41	
1	1	-	A	23241-6	BALL, STEEL	40
1	1	-	A	690170-1	SPRING, COMPRESSION	39
1	1	-	C	690142-1	DISC, INSULATION	38
1	1	-	D	354777-1	WIRE DISC, PLASTIC	37
1	1	-	A	22480-5	WASHER, SPRING	36
1	1	-	B	690212-1	POST, RAM	35
					34	
					33	
					32	
					31	
					30	
					29	
1	1	-	B	690451-1	SPACER, STRIPPER	28
1	1	-	A	458265-2	STRIPPER	27
1	1	-	D	458263-1	PLATE, BASE	26
4	4	-	A	22354-7	DRAG, STUD	25
1	1	-	B	1-458262-5	PLATE, STRIP GUIDE	24
					23	
2	2	-	A	461389-1	SPRING, DRAG	22
1	1	-	A	458260-1	DRAG, STOCK (LEFT)	21
1	1	-	A	458259-1	DRAG, STOCK (RIGHT)	20
1	1	-	B	458258-5	GUIDE, STRIP (REAR)	19
1	1	-	C	458257-5	GUIDE, STRIP (FRONT)	18
					17	
					16	
1	1	-	B	1-458309-1	GUIDE, CENTER STRIP	15
					14	
1	1	-	C	1-690784-0	PLATE, BENDING	13
					12	
1	1	-	B	458255-6	PLATE, REAR SHEAR	11
2	2	-	C	1-240645-0	SPACER, SHEAR PLATE	10
1	1	-	B	458255-7	PLATE, FRONT SHEAR	9
2	2	-	D	6-238169-4	ANVIL	8
1	1	-	B	238074-4	BLADE, SLUG	7
					6	
1	1	-	C	1-238075-2	SPACER, SLUG BLADE	5
1	1	-	B	238009-1	SPACER, BLOCK CRIMPER	4
1	1	-	C	458251-5	CRIMPER, INSULATION	3
1	1	-	B	455888-8	SPACER, CRIMPER	2
1	1	-	C	2-458954-1	CRIMPER, WIRE	1

QTY	REV	U/M	DWG SIZE	PART NO	DESCRIPTION	ITEM NO
-2	-1					
REVISION OF EACH ASSY NO (WHEN BLANK, USE DWG REVISION)						
PARTS LIST						

QTY	REV	U/M	DWG SIZE	PART NO	DESCRIPTION	ITEM NO
-2	-1					
REVISION OF EACH ASSY NO (WHEN BLANK, USE DWG REVISION)						
PARTS LIST						

THIS DRAWING IS A CONTROLLED DOCUMENT.

MAY 28, 1995

RELEASED FOR PUBLICATION  
BY AMP INCORPORATED. ALL RIGHTS RESERVED.

THIS DRAWING IS UNAPPROVED  
COPYRIGHT 1999

LOC  
A  
DIST  
66

DIMENSIONS IN INCHES. DO NOT SCALE PRINT. TOLERANCES UNLESS OTHERWISE SPECIFIED:  
 2 PLC DEC ±.25  
 3 PLC DEC ±.25  
 4 PLC DEC ±.  
 ANGLES ±.  
 SURF TEXTURE: ✓  
 REMOVE BURRS, BREAK SHARP EDGES R.015 MAX

MATL - HT TR - FIN -

DR 7/19/93 APP 7-27-93  
 M. O'BRINE B. WOLFE  
 CHK 7-27-93 REL 8/6/93  
 C. ERISMAN B. MORGAN

**AMP** AMP Incorporated  
 Harrisburg, PA 17105-3608

NAME END FEED HDM DUAL APPLICATOR MACHINE REF  
 SCALE - DWG NO 680021 SHEET 1 OF 1 REV A3

CASE CODE 00779 CUSTOMER AND ASSEMBLY DRAWING RESTRICTED TO