



Coolant inlet and outlet are marked with symbols: Inlet: \uparrow ; outlet: \circ

CAUTION: READ MANUAL BEFORE OPERATING COOLING UNIT

- Input power must be rated for 230 VAC at 50 or 60 Hz.
- Use water or water/glycol as coolant.
- Run the cooling unit at the correct coolant level, otherwise cooling capacity will be reduced.
- Clean the filter periodically, otherwise the pump may degrade over time.
- Use cooling hoses that can handle max pressure of liquid circuit and is resistant to corrosion from coolant.
- Never operate the unit if it is damaged or leaking.
- Before starting any service work on the cooling unit, please disconnect from the main power source.

global solutions: local support™

Americas: +1.888.246.9050

Europe: +46.31.704.67.57

Asia: +86.755.2714.1166

WL 5000

Liquid Cooling System

USER MANUAL

TABLE OF CONTENTS

	Pg No.
1 Description	2
2 Technical Data	3
2.1 Physical Dimensions	3
2.2 Performance Data	3
2.3 Environmental Specifications	3
2.4 Settings	3
3 Operational Settings	4
4 Maintenance	5
4.1 Heat exchanger	5
4.2 Pump	5
5 Placing out of Operation	6
6 Spare Parts List and Illustration	6
7 Liquid and Electrical Diagram	8

DESCRIPTION

The WL 5000 cooling unit is intended to remove heat from a liquid circuit. The coolant can be either water or a mixture of water and water-glycol (antifreeze). Water circulates in a closed loop between the ambient cooling system and a cold plate at the heat source. Heat is removed from water by an air-cooled heat exchanger. The capacity of the cooling unit is dependent on the temperature differential, which is defined as the difference between the ambient temperature and the water outlet temperature. The cooling unit is designed to remove 5000 W of heat at a temperature differential of 13°C. The maximum forward pressure is limited by a bypass valve, which has been integrated into the pump. The coolant flow is controlled by a flow switch that opens when flow falls below a set rate. Cooling hoses supplied by user are connected to threaded nozzle that can accommodate a 9 mm hose ID.

Note: Flow switch and bypass valve are adjusted at factory according to specifications in this document.

2 TECHNICAL DATA**2.1 PHYSICAL DIMENSIONS**

- Length: 483 mm
- Width: 406 mm
- Height: 481 mm
- Weight: 38.5 kg without filling
- Coolant capacity: 5.0 L

2.2 PERFORMANCE DATA

- Cooling capacity: 5000 W
- Flow rate: 6.5 lpm at 3 bar
- Mains voltage: 230 V \pm 10% / 50/60 Hz
- Current consumption: 2.6 A
- Noise level: 63 dB(A) (50 Hz)
67 dB(A) (60 Hz) distance 1 m in any direction

2.3 ENVIRONMENTAL SPECIFICATIONS

- Operating temperature: +5°C to +40°C (-10°C with water-glycol coolant mixture)
- Storage temperature: -25°C to +70°C (storage without water)
- Air humidity: 20% to 80%

2.4 SETTINGS

- Maximum forward pressure: 7 bar \pm 0.5 bar
- Flow switch open: 4 lpm with hysteresis < 0.8 lpm
- Thermal switch open: 50°C \pm 3°C, hysteresis < 10°C

3 OPERATIONAL SETTINGS

1. Position the cooling unit horizontally and keep obstructions away from the air inlet to allow for sufficient air circulation.
2. Remove the reservoir cap.
3. Connect the external hoses supplied by the user.
4. Insert the cable and connect the cable to the terminals according to the terminal diagram; use a 3 mm screwdriver to connect the wires to the terminal block.
5. Fill the cooling unit with approximately 5.0 L of coolant.

Note: The coolant level must be approximately 3 cm above the fins to maintain peak cooling performance, otherwise the cooling capacity will be reduced.

6. Allow the cooling unit to run for 10 minutes and deaerate the liquid circuit.
7. Check the coolant level and refill if necessary.
8. Close the reservoir cap.



4 MAINTENANCE

Check the coolant level regularly and refill if necessary.

4.1 HEAT EXCHANGER

In order to achieve maximum cooling capacity, the heat exchanger of the cooling unit must be kept clean. Check the heat exchanger every three months for cleanliness. If cleaning is required, perform the following:

1. Disconnect the cooling unit from the main power source.
2. Remove the side cover.
3. Clean the heat exchanger with compressed air, a damp cloth or shop vacuum.
4. Mount the side cover.

4.2 PUMP

The pump has incorporated a coolant filtering mechanism to keep debris out of the pump. It is recommended to check the filter every three months to make sure it is clean. If cleaning is required, then perform the following:

Note: If the filter is not cleaned, then degradation to pump may occur.

1. Disconnect the cooling unit from the main power source and external hoses.
2. Drain the coolant from the reservoir.
3. Remove the side cover.
4. Close the ball cock.
5. Unscrew the filter cap with a wrench that can accommodate a 24 mm nut.

Note: Some coolant may run out from the pump. Collect in a suitable container.

6. Remove the filter and clean with mild soap and water or replace.
7. Insert the filter into the housing and tighten the nut.
8. Open the ball cock.

Note: Do not operate the cooling unit when the ball cock is closed, as this can damage the pump.

9. Mount the side cover and reposition the cooling unit on its legs.
10. Refill the coolant in reservoir and run for 10 minutes to deaerate.
Check the coolant level and refill if necessary.

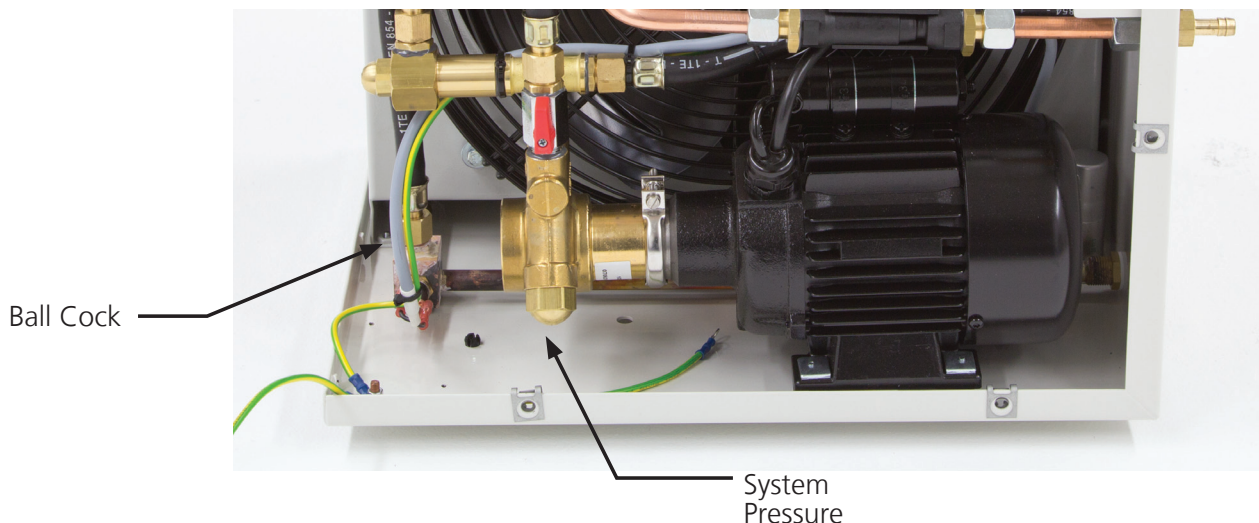

WL 5000

Liquid Cooling System

USER MANUAL

5 PLACING OUT OF OPERATION

1. Disconnect the cooling unit from the main power source.
2. Remove the electrical connections.
3. Remove the hoses from the cooling unit.
4. Remove the cap and drain the coolant in a suitable container.
5. Mount the cap on the drain.



6 SPARE PARTS LIST AND ILLUSTRATION

NO.	DESCRIPTION	CODE NUMBER
1	Cap	91729015
2	O-Ring for cap	93300405
3	Flow switch	95249902
4	Thermal switch	95160036
5	Lid	95179902
6	Motor	95205201
7	Pump	12321902.70
8	Flexible coupling	95205203
9	Fan	95251635
10	Capacitor for fan	95290701
11	Filter	96299012

6 SPARE PARTS LIST AND ILLUSTRATION

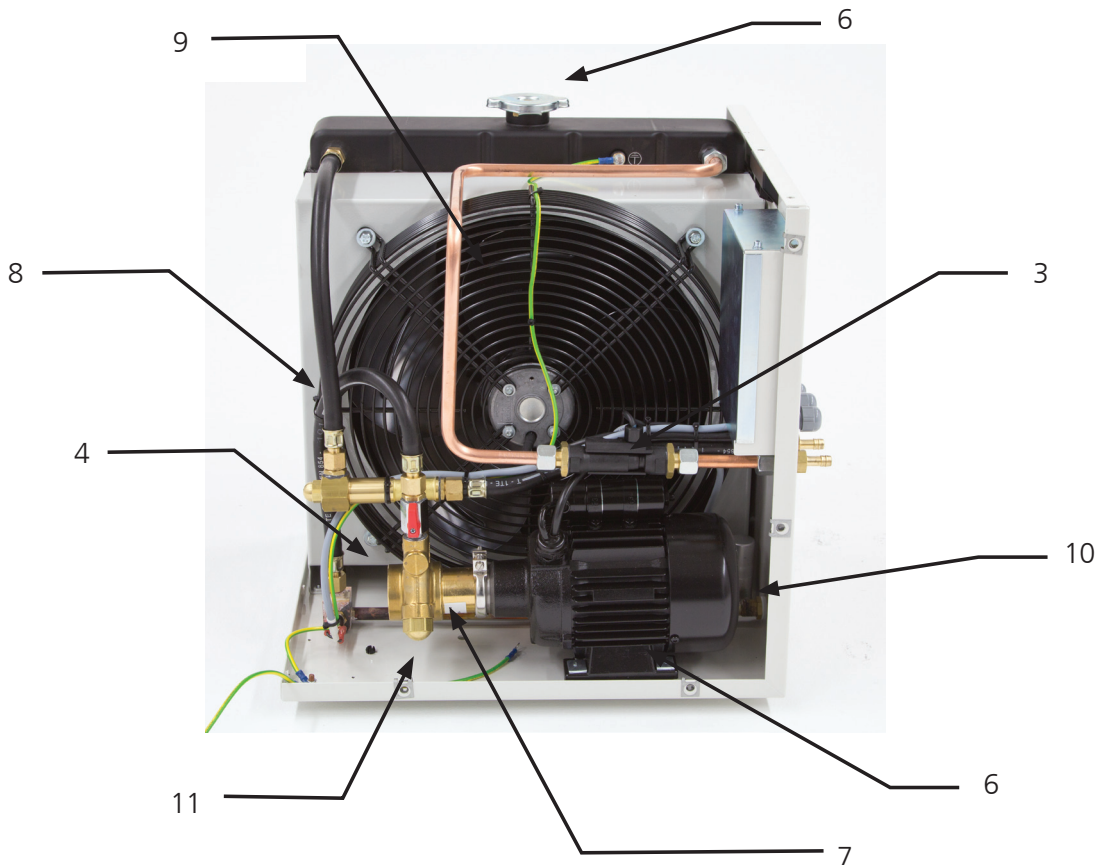
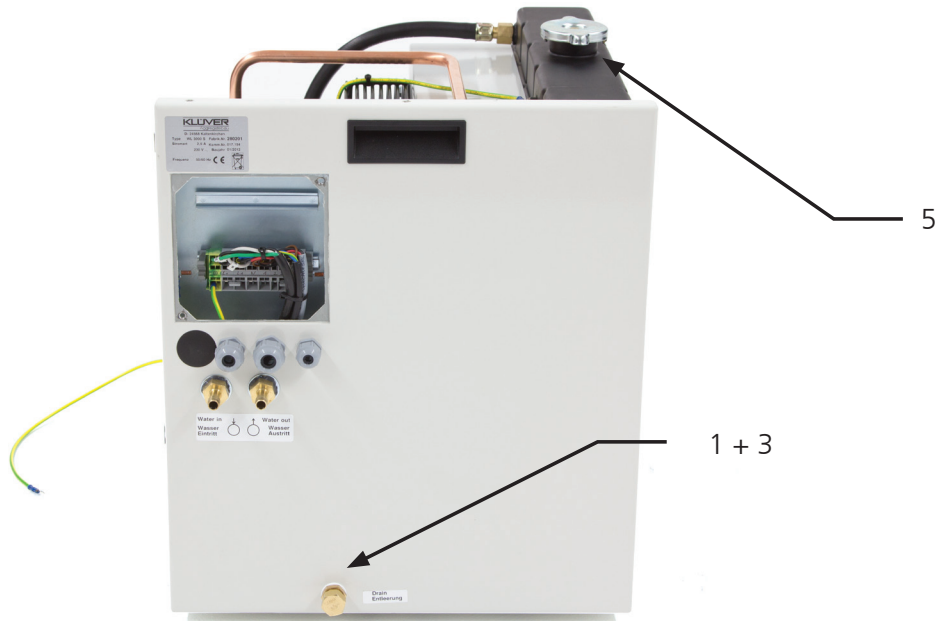

LIQUID CIRCUIT DIAGRAM

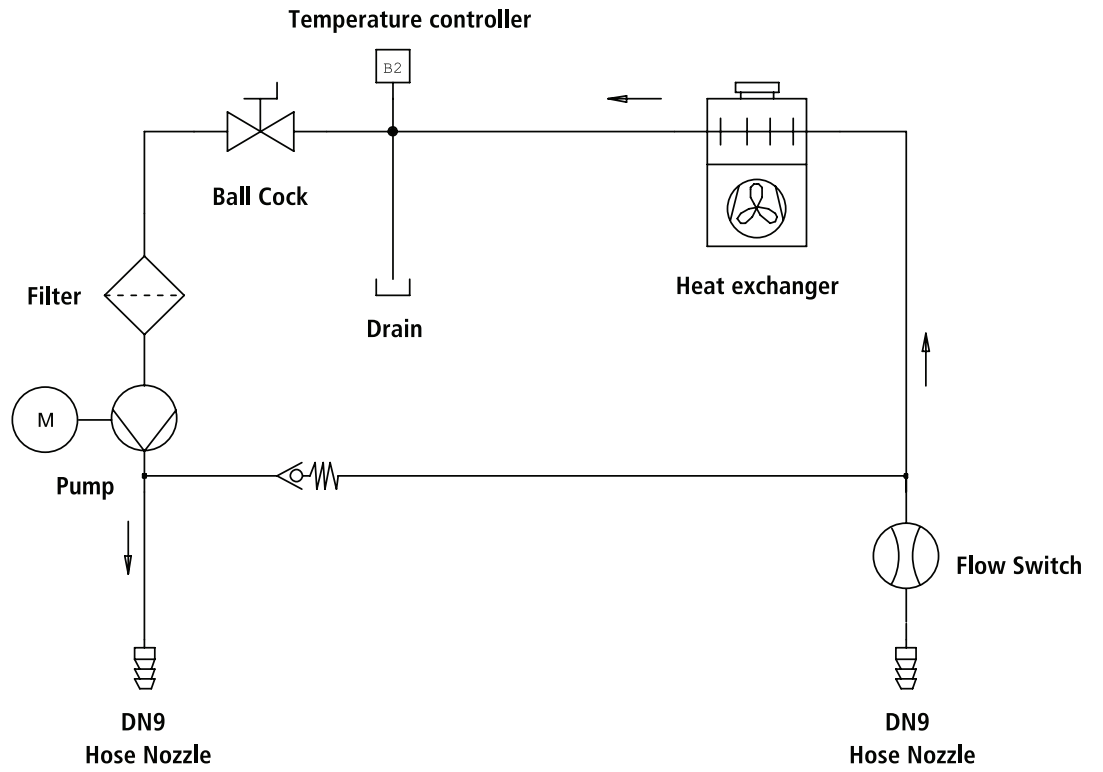

ELECTRONIC SCHEMATIC

Wiring diagram

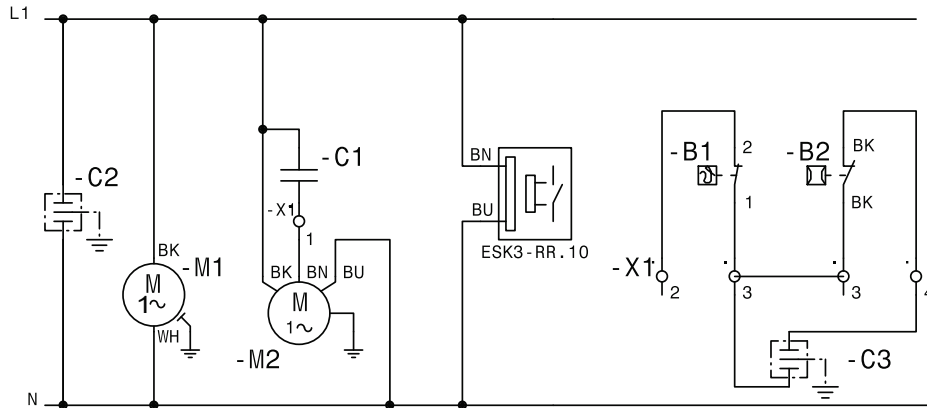

Safety circuit

Terminal connection table

M16 - plug

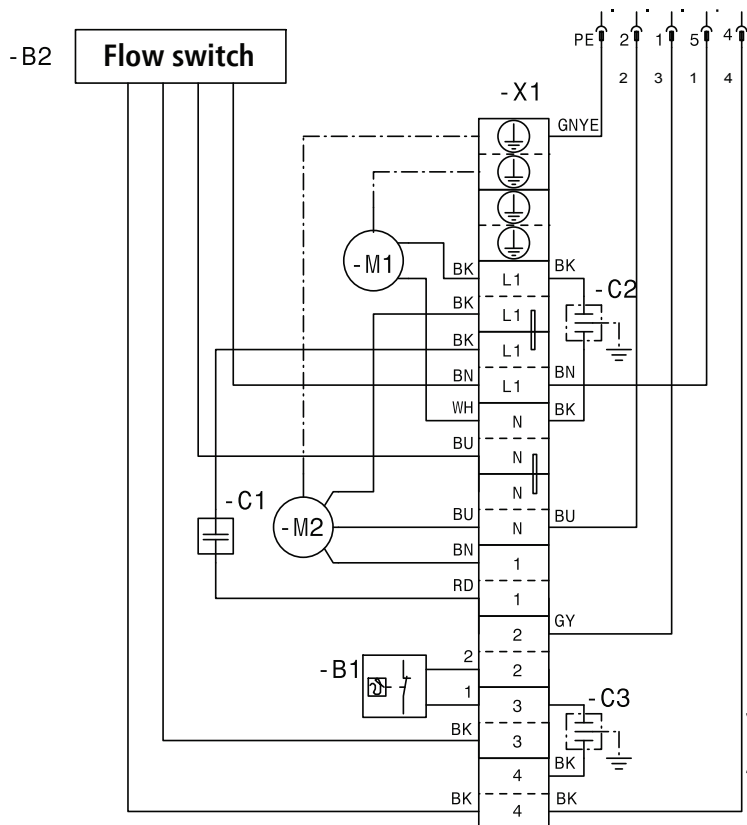

- B1** Temperature max
- B2** Flow switch
- C1** Capacitor
- C2** Radio interference suppression capacitor
- C3** Radio interference suppression capacitor
- M1** Pump
- M2** Fan

Safety circuit

THR-UM-WL-5000 0912

Any information furnished by Laird Technologies, Inc. and its agents is believed to be accurate and reliable. All specifications are subject to change without notice. Responsibility for the use and application of Laird Technologies materials rests with the end user. Laird Technologies makes no warranties as to the fitness, merchantability, suitability or non-infringement of any Laird Technologies materials or products for any specific or general uses. Laird Technologies shall not be liable for incidental or consequential damages of any kind. All Laird Technologies products are sold pursuant to the Laird Technologies' Terms and Conditions of sale in effect from time to time, a copy of which will be furnished upon request. © Copyright 2012 Laird Technologies, Inc. All Rights Reserved. Laird, Laird Technologies, the Laird Technologies Logo, and other marks are trade marks or registered trade marks of Laird Technologies, Inc. or an affiliate company thereof. Other product or service names may be the property of third parties. Nothing herein provides a license under any Laird Technologies or any third party intellectual property rights.