



## MachXO2 Pico Development Kit

---

**User's Guide**

---

## Introduction

Thank you for choosing the Lattice Semiconductor MachXO2™ Pico Development Kit.

This guide describes how to begin using the MachXO2 Pico Development Kit, an easy-to-use platform for rapidly prototyping system control designs using MachXO2 PLDs. Along with the evaluation board and accessories, this kit includes the pre-loaded Pico SoC Demo (Environment Scanning Demonstration Design) that demonstrates board diagnostic functions including ultra-low power, LCD driver, I/O control, current measuring, time stamps and data logging to non-volatile memory using the 8-bit LatticeMico8™ microcontroller.

The contents of this user's guide include demo operation, top-level functional descriptions of the various portions of the evaluation board, descriptions of the on-board connectors, switches, a complete set of schematics and the bill of materials for the MachXO2 Pico Evaluation Board.

*Note: Static electricity can severely shorten the lifespan of electronic components. See the [MachXO2 Pico Development Kit QuickSTART Guide](#) for handling and storage tips.*

## Features

The MachXO2 Pico Development Kit includes:

- **MachXO2 Pico Evaluation Board** – The MachXO2 Pico Evaluation Board features the following on-board components and circuits:
  - MachXO2 LCMXO2-1200ZE PLD device in a 132-ball csBGA package. The board is designed for density migration, allowing a lower density MachXO2 device to be assembled on the board.
    - Part number LCMXO2-1200ZE-P-EVN is populated with the R1 silicon. Part number LCMXO2-1200ZE-P1-EVN is populated with the Standard silicon. The demos have been targeted for a specific version of silicon and are not interchangeable. For more information on the R1 to Standard migration refer to AN8086, [Designing for Migration from MachXO2-1200-R1 to Standard \(Non-R1\) Devices](#)
    - 4 Mbit SPI Flash memory
  - Current sensor circuits using Delta-Sigma ADC
  - LCD driven with PWM analog output circuitry
  - Expansion header for JTAG, SPI, I<sup>2</sup>C and PLD I/Os
  - 4 capacitive touch sense buttons
  - Standard USB cable for device programming
  - RS-232/USB and JTAG/USB interface
  - RoHS-compliant packaging and process
  - USB or 2032 battery powered
- **Pre-loaded Reference Designs and Demo** – The kit includes a pre-loaded Pico SoC Demo design that integrates several Lattice reference designs including: the LatticeMico8 microcontroller, master WISHBONE bus controller, soft delta-sigma ADC, SPI master controller, UART peripheral, Embedded Block RAM and additional control functions.
- **USB connector Cable** – A mini B USB port provides power, a communication and debug port via a USB-to-RS-232 physical channel and programming interface to the MachXO2 JTAG port.
- **Battery** – A 2032 coin battery can provides an alternate source of power.
- **QuickSTART Guide** – Provides information on connecting the MachXO2 Pico Evaluation Board, installing Windows hardware drivers, and running the Pico SoC Demo.

Figure 1 shows the top side of the MachXO2 Pico Evaluation Board with comments on the specific features that are designed in the board.

Figure 1. MachXO2 Pico Evaluation Board, Top Side

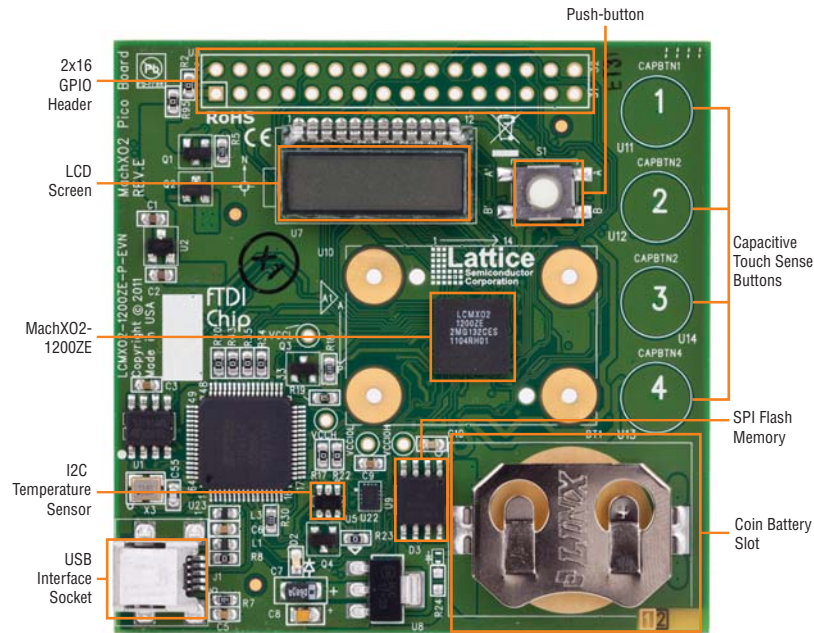

## MachXO2 Device

This board features a MachXO2 PLD with a 1.2V core supply. The PLD is packaged in a 132-ball csBGA which provides a migration path to devices ranging from 640 LUTs to 4340 LUTs. A complete description of this device can be found in the [MachXO2 Family Handbook](#).

## Software Requirements

You should install the following software before you begin developing designs for the evaluation board:

- Lattice Diamond™ 1.2 (or higher)
- ispVM™ System 17.9.1 (or higher)

## Demonstration Design

Lattice provides the Pico SoC Demo design programmed in the board. The design utilizes the MachXO2 in the context of low power applications.

The Pico SoC Demo illustrates the use of the LatticeMico8 microcontroller, associated peripherals and firmware to provide a low power system featuring voltage/current measurement, data logging to nonvolatile memory, I/O control, embedded block RAM utilization, UART communication, capacitive touch sense buttons and a LCD controller.

- The LatticeMico8 executable program initializes the peripherals that are embedded in the SoC design. During initialization, the LatticeMico8 uploads the user menu on the Terminal of a PC.
- Users interact with LatticeMico8 and the board through the Terminal of a PC or through the capacitive touch sense buttons.

Figure 2. Pico SoC Demo Block Diagram

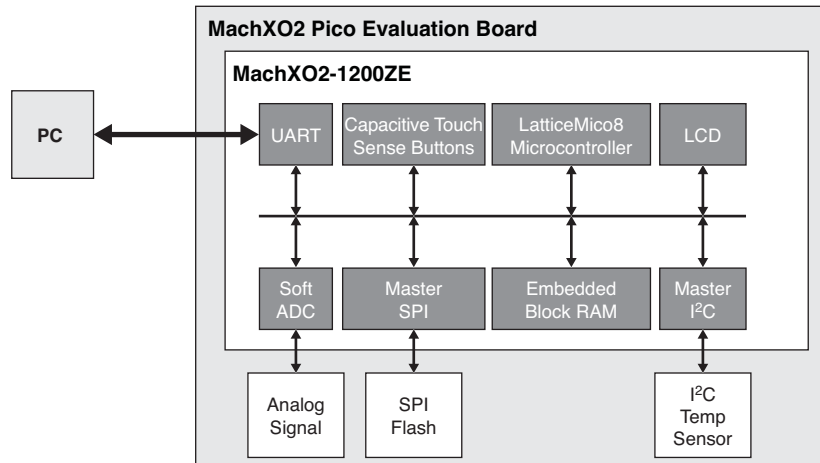

Power management is handled in two phases by the MachXO2 Pico Evaluation Board system:

1. MachXO2 Function – After the reset is de-asserted, LatticeMico8 initializes the peripherals embedded in the MachXO2 device and uploads the user menu onto the HyperTerminal window of a PC.

Figure 3. HyperTerminal User Menu

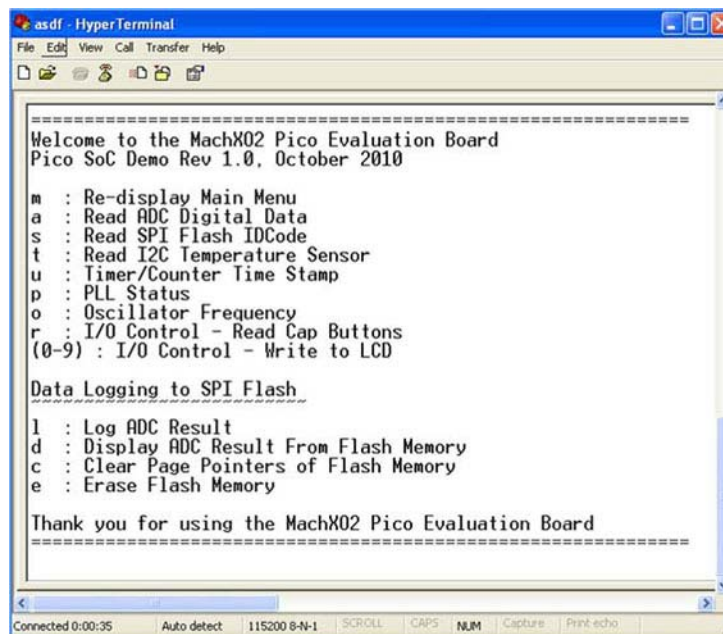

2. Users interact with LatticeMico8 microcontroller and the board by selecting the available options in the HyperTerminal menu. The available options are:

- ‘m’ – This option re-displays the main menu anytime during the demonstration. PICO is displayed on the LCD screen.
- ‘i’ – This option measures the Icc using a Delta Sigma. The result is displayed to the terminal and the LCD. Board button 3 performs the same function but results are only displayed to the LCD.
- ‘o’ – This option measures Icco using Delta Sigma. The result is displayed to the terminal and the LCD. Pressing board button 2 performs the same function but results are only displayed to the LCD.

- 's' – This option reads the device ID of the SPI Flash on the board. The results are displayed to the terminal and the LCD.
- 't' - This option reads the I2C temperature sensor on the board. The result is displayed to the Terminal and to the LCD. Button 4 on the board performs the same function but the result is only displayed on the LCD
- 'r' This option samples the capacitive touch buttons on the board and displays the data in the terminal.
- "0-9" - These values will echoed to the terminal and displayed on the LCD
- 'l' - This option will read the Icc, Icco, and Temperature and log it to the SPI flash memory. The WRITE page pointer will increment when 'l' is pressed. The initial value of the page pointer after power up is a 0. Button 1 on the board performs the same function the LCD will display 8888
- 'd' - This option will read the data from the SPI Flash device and display to to the Terminal window. The READ page pointer will increment when 'd' is pressed. The initial value of the page pointer after a power up is 0.
- 'c' - This option will clear (reset) the WRITE and READ page pointers
- 'e' - This selection will perform a bulk-erase of the Flash memory in the SPI Flash device and will clear (reset) the WRITE and READ page pointers.

## Setting up the Board

### Drivers and Firmware

Before you begin, you will need to obtain the necessary hardware drivers for Windows from the Lattice web site.

1. Browse to [www.latticesemi.com/alpha-mxo2-pico-kit](http://www.latticesemi.com/alpha-mxo2-pico-kit) and locate the hardware device drivers for the USB interface.
2. Download the ZIP file to your system and unzip it to a location on your PC.

Linux Support:

The USB interface drivers for the evaluation board are included in Linux kernel 2.4.20 or greater, including distributions compatible with Lattice Diamond design software (Red Hat Enterprise v.3, v.4 or Novell SUSE Enterprise v.10).

The Pico SoC Demo is preprogrammed into the MachXO2 Pico Evaluation Board, however over time it is likely that your board will be modified.

To download the demo source files and reprogram the MachXO2 Pico Evaluation Board:

1. Download the demo application source code from [www.latticesemi.com/alpha-mxo2-pico-kit](http://www.latticesemi.com/alpha-mxo2-pico-kit).
2. Use `.\Environment_Scanning_demo\project\impl1\Environment_Scanning_demo_impl1.jed` to restore the Environment Scanning demonstration design.

### Connecting to the MachXO2 Pico Evaluation Board

1. Connect the evaluation board to your PC using the USB cable provided. The USB connector on the board includes reference designator J1. Once the connection is made, a blue LED with reference designator D2 will illuminate.
2. If you are prompted "Windows may connect to Windows Update", select **No, not this time** from available options and click **Next** to proceed with the installation.
3. Choose the **Install from specific location (Advanced)** option and click **Next**.
4. Select **Search for the best driver in these locations** and click the **Browse** button to browse to the Windows driver folder created earlier. Select the **CDM 2.04.06 WHQL Certified** folder and click **OK**.
5. Click **Next**. A screen will display as Windows copies the required driver files. Windows will display a message indicating that the installation was successful.

## Programming the MachXO2

Using ispVM System software, users can scan and perform JTAG operations, including programming, with the MachXO2 device.

### Setting Up Windows HyperTerminal

You will use a terminal program to communicate with the evaluation board. The following instructions describe the Windows HyperTerminal program which is found on most Windows PCs. You may use another terminal program but setup will be somewhat different. Windows 7 does not include HyperTerminal. Tera Term has been verified to work with Windows 7. For Linux, Minicom is a good alternative.

*Note: This step uses the procedure for Windows XP users. Steps may vary slightly if using another Windows version.*

1. From the **Start** menu, select **Control Panel > System**. The “System Properties” dialog appears.
2. Select the **Hardware** tab and click **Device Manager**. The “Device Manager” dialog appears.

**Figure 4. Device Manager – COM Port**

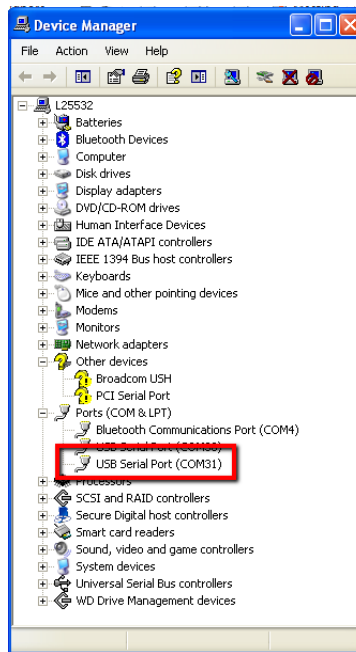

3. Expand the **Ports (COM & LPT)** entry and note the COM port number for the USB Serial Port.
4. From the **Start** menu, select **Programs > Accessories > Communications > HyperTerminal**. The HyperTerminal application and a “Connection Description” dialog appear.

Figure 5. New Connection – COM Port



5. Specify a Name and Icon for the new connection. Click **OK**. The “Connect To” dialog appears.
6. Select the COM port identified in Step 3 from the Connect using: list. Click **OK**.

Figure 6. Selecting the COM Port



7. The “COMn Properties” dialog appears where “n” is the COM port selected from the list.
8. Select the following Port Settings and click **OK**.
  - Bits per second: **115200**
  - Data bits: **8**
  - Parity: **None**
  - Stop bits: **1**
  - Flow control: **None**

Figure 7. COM Port Properties

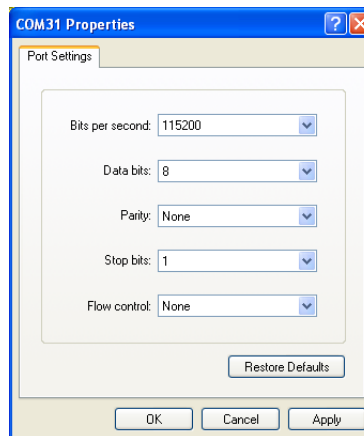

9. The HyperTerminal window appears.
10. From the MachXO2 Pico Evaluation Board, press the reset push-button with reference designator S1. The Pico SoC demo main menu appears.

### Setting Up Linux Minicom

Minicom is a terminal program found with most Linux distributions. It can be used to communicate with the MachXO2 Pico Evaluation Board.

To setup Minicom:

1. Check active serial ports:

```
#dmesg | grep tty
```

Note the tty label assigned to the USB port

2. From a command prompt, start Minicom:

```
#minicom -s
```

The configuration menu appears.

3. Highlight **Serial port setup** and press **Enter**. Serial port settings appear.
4. Press **A** (Serial Device). Specify the active serial device noted in Step 1 and press **Enter**.
5. Press **E** (Bps/Par/Bits). Specify **115200**, **None**, **8** and press **Enter**.
6. Press **F** (Hardware Flow Control). Specify **None** and press **Enter**.
7. Press **Esc**. The configuration menu appears.
8. Select **Save setup as dfl**. Minicom saves the port setup as the new default.
9. Select **Exit**. The Minicom interface appears.
10. From the evaluation board, press the **S1** push-button (GSR). The Pico SoC demo main menu appears.

### Ordering Information

| Description                  | Ordering Part Number | China RoHS Environment-Friendly Use Period (EFUP)                                     |
|------------------------------|----------------------|---|
| MachXO2 Pico Development Kit | LCMXO2-1200ZE-P-EVN  |  |

### Technical Support Assistance

Hotline: 1-800-LATTICE (North America)  
 +1-503-268-8001 (Outside North America)  
 e-mail: [techsupport@latticesemi.com](mailto:techsupport@latticesemi.com)  
 Internet: [www.latticesemi.com](http://www.latticesemi.com)



## Revision History

| Date          | Version | Change Summary   |
|---------------|---------|--|
| February 2011 | 01.0    | Initial release.   |
| April 2011    | 01.1    | Updated Pico Evaluation Board Top Side diagram, Pico SoC Demo block diagram, HyperTerminal User Manual information, Appendix A and Appendix B.                                   |
| June 2011     | 01.2    | Added Appendix C.  |
| July 2011     | 01.3    | Updated Features list with information on migration from MachXO2-1200-R1 to Standard (non-R1) devices.   |
| July 2011     | 01.4    | Added limitations section to Appendix C.   |
| December 2011 | 01.5    | Added Appendix D.  |
| February 2012 | 01.6    | Updated document with new corporate logo.  |
| June 2012     | 01.7    | Added Appendix D, Dual Boot Demonstration.<br>Updated Appendix E, Limitations.   |
| June 2012     | 01.8    | Added "MachXO2 Pico Evaluation Board I <sup>2</sup> C Bus Power Enable" diagram to Appendix D.   |
| July 2012     | 01.9    | Appendix D figure title changed from "MachXO2 Pico Evaluation Board I <sup>2</sup> C Bus Power Enable" to "MachXO2 Pico Evaluation Board SPI/I <sup>2</sup> C Bus Power Enable". |
| October 2012  | 02.0    | Highlighted board limitations and workarounds in the demos.  |

© 2012 Lattice Semiconductor Corp. All Lattice trademarks, registered trademarks, patents, and disclaimers are as listed at [www.latticesemi.com/legal](http://www.latticesemi.com/legal). All other brand or product names are trademarks or registered trademarks of their respective holders. The specifications and information herein are subject to change without notice.

## Appendix A. Schematic

Figure 8. USB 5V, MachXO2 Power Rails, 3.0V Battery, 1.2V Rail and Current Monitors

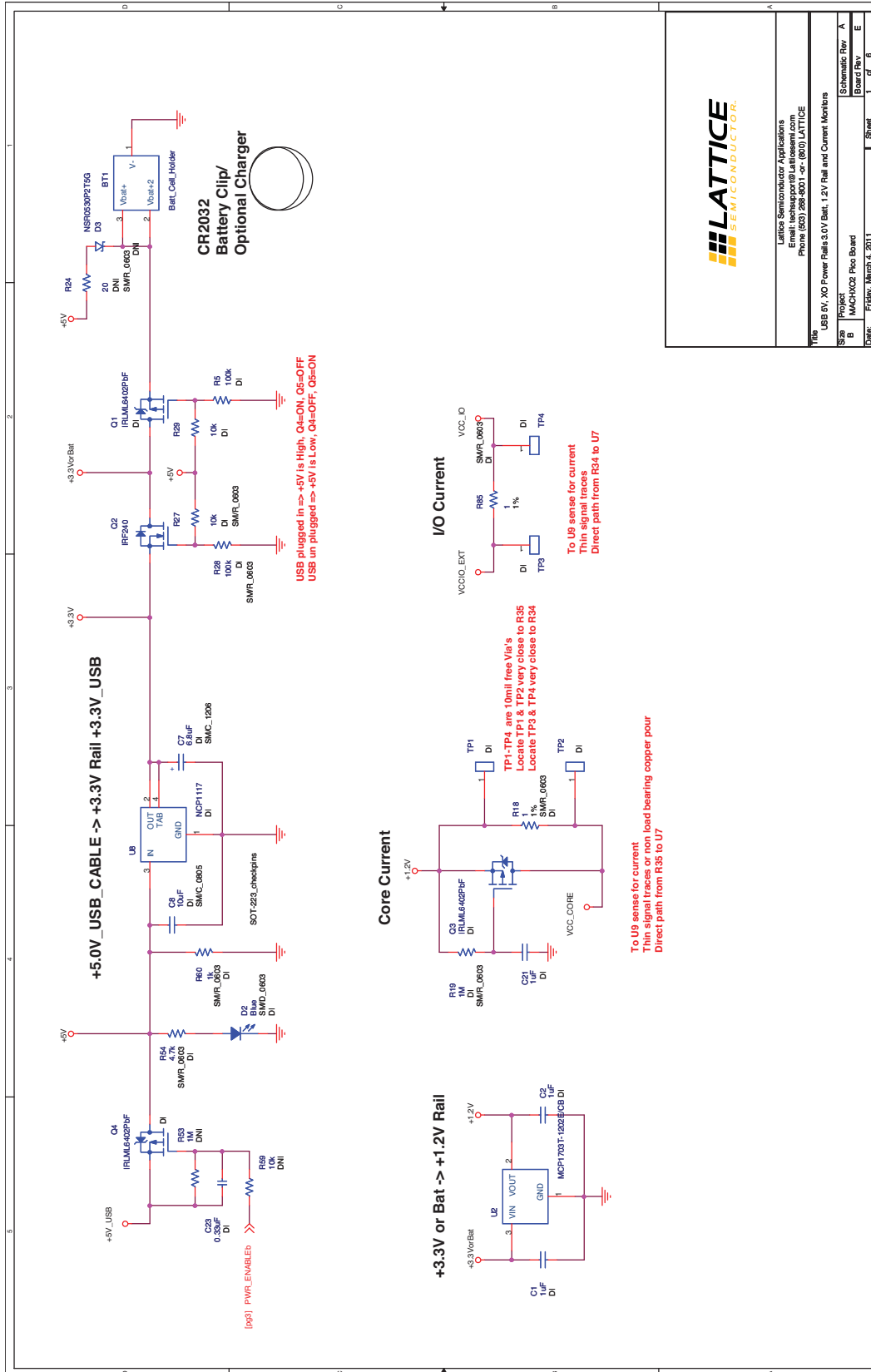

**LATTICE**  
SEMICONDUCTOR

Lattice Semiconductor Applications  
 Email: techsupport@lattice.com  
 Phone (650) 286-8001 ext. (800) LATTICE

This USB 5V, XO Power Rails 3.0V Batt, 1.2V Rail and Current Monitors

Sheet 1 of 6

Rev B

DATE: Friday, March 2, 2011

Sheet 1 of 6

Schematic Rev A

Board Rev E

Figure 9. Current Sense Amplifiers, Power Enable Mux

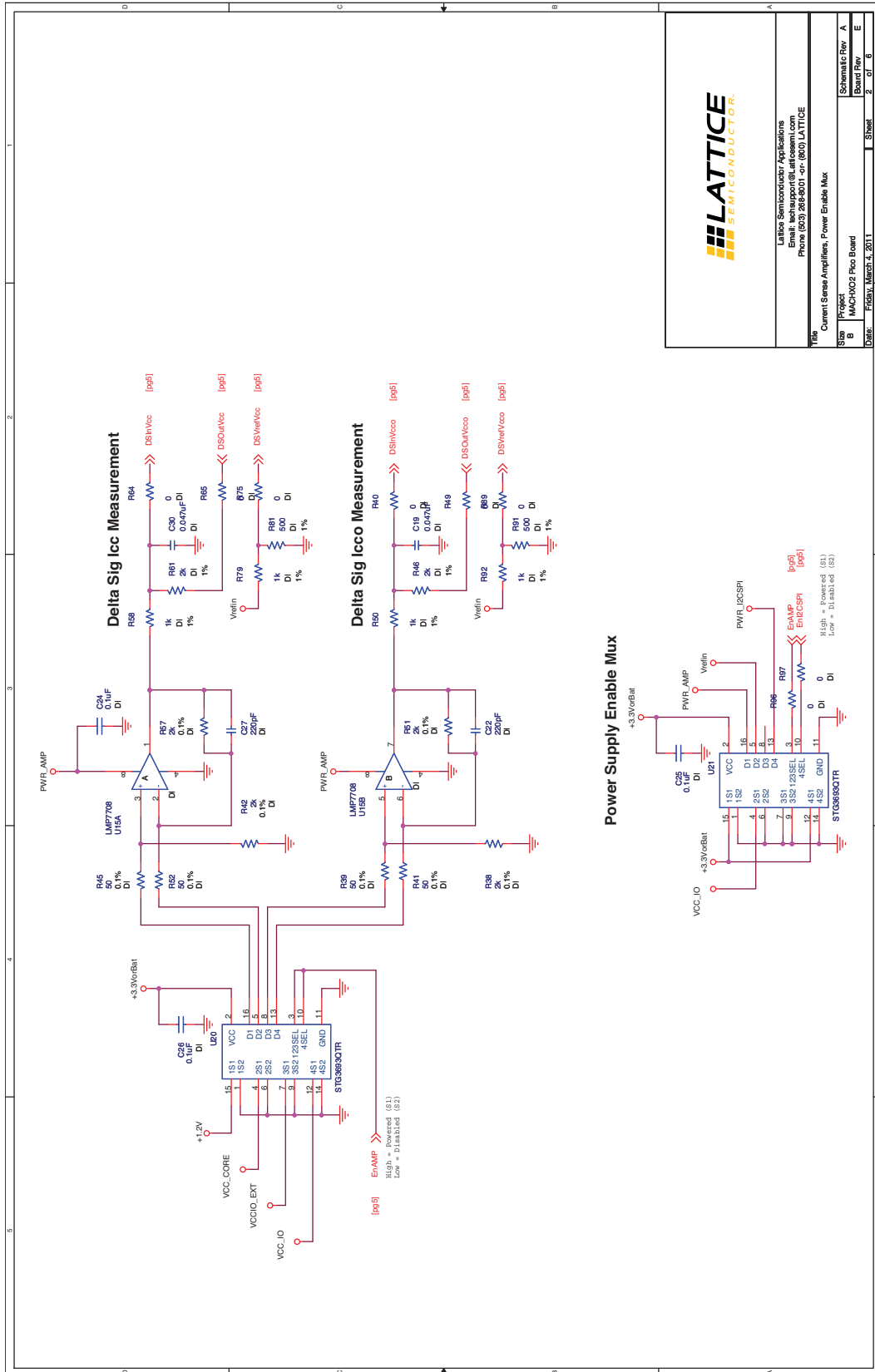

|  |                  |
|--|------------------|
| Lattice Semiconductor Applications<br>Email: techsupport@lattice.com<br>Phone: (800) 866-8017 or (602) LATTICE |                  |
| Title: Current Sense Amplifiers, Power Enable Mux  |                  |
| Sheet: 1 of 2  | Schematic Rev: A |
| Board: MachXO2 Pico Board  | Board Rev: E     |
| Date: Friday, March 4, 2011  | Sheet: 2 of 6    |

Figure 10. USB to JTAG and I<sup>2</sup>C for the MachXO2

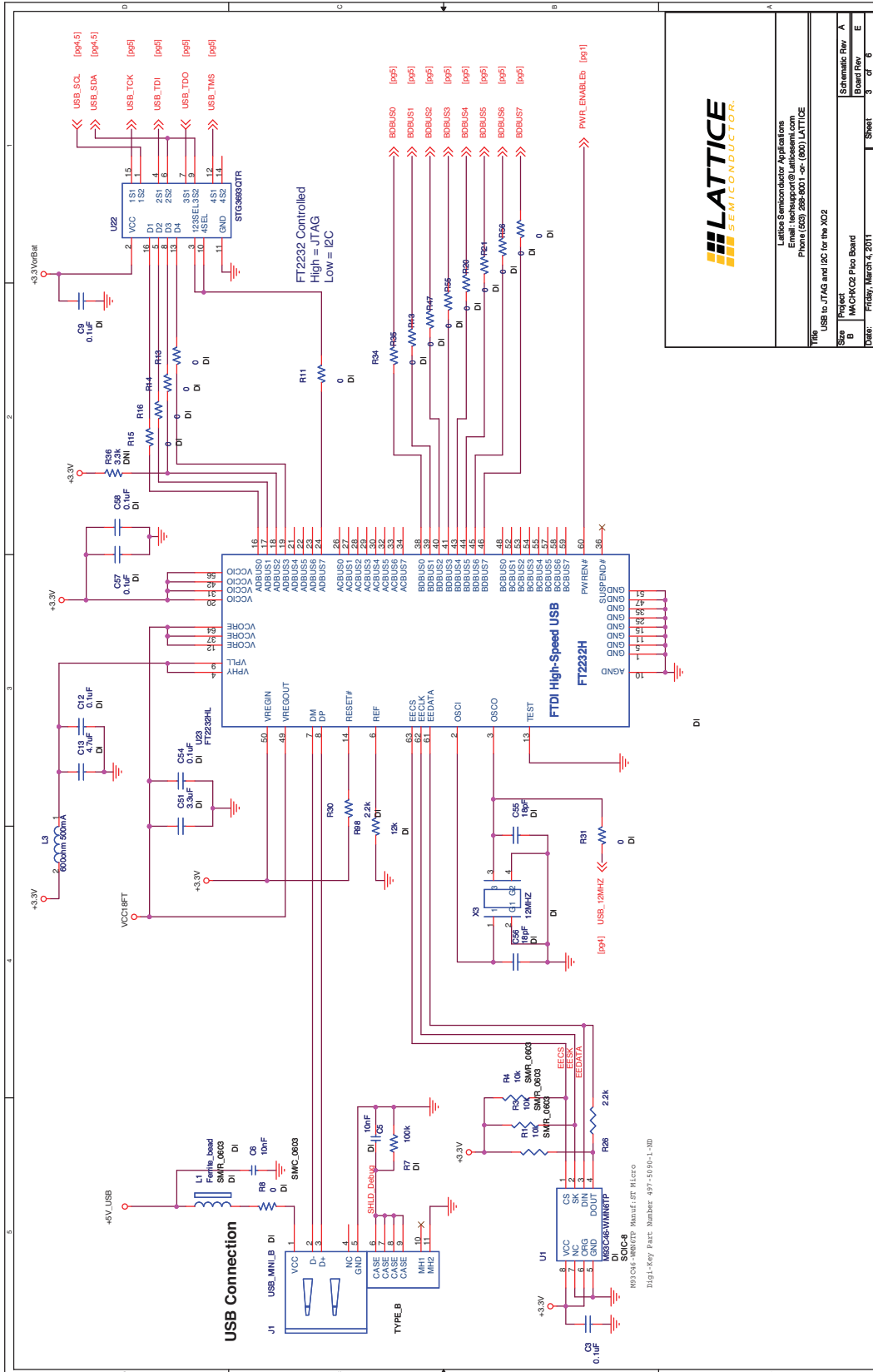

**LATTICE**  
SEMICONDUCTOR

Lattice Semiconductor Applications  
Email: [techsupport@lattice.com](mailto:techsupport@lattice.com)  
Phone: (650) 586-5800 or (800) LATTICE

Title: USB to JTAG and I<sup>2</sup>C for the XO2

Size: B

Project: MACHXO2 Pico Board

Schematic Rev: A

Sheet: 3 of 6

Date: Fri, 03 Mar 2011

Figure 11. MachXO2 Banks 0-1, LCD,  $\mu$ C Temperature

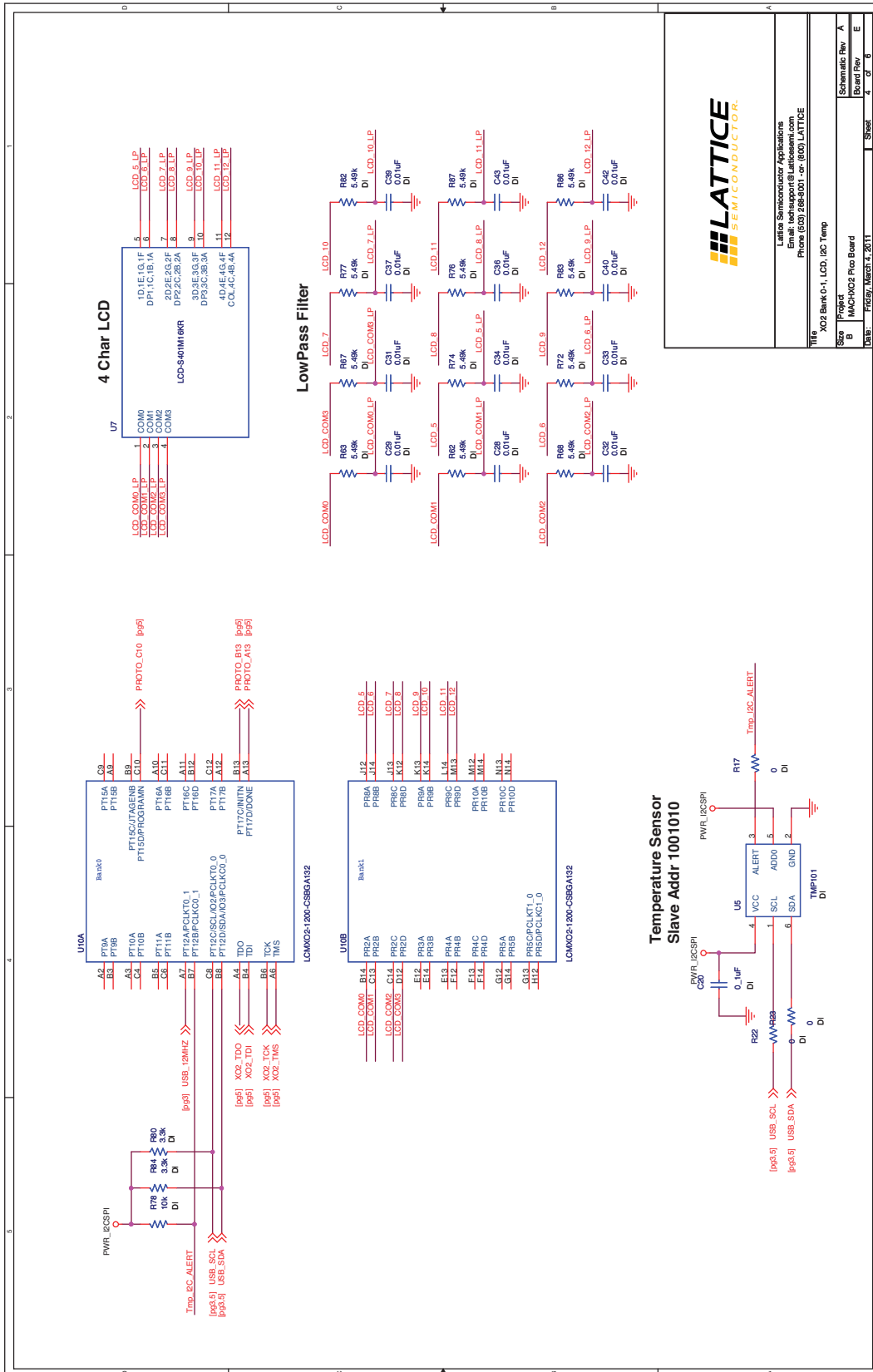

Lattice Semiconductor Applications  
Email: techsupport@latticesemi.com  
Phone: (603) 288-6001 or (800) LATTICE

MachXO2 Bank 0-1, LCD,  $\mu$ C Temp

Sheet 4 of 6

Figure 12. MachXO2 Banks 2-3, Capacitor Pads, Expansion Header, SPI

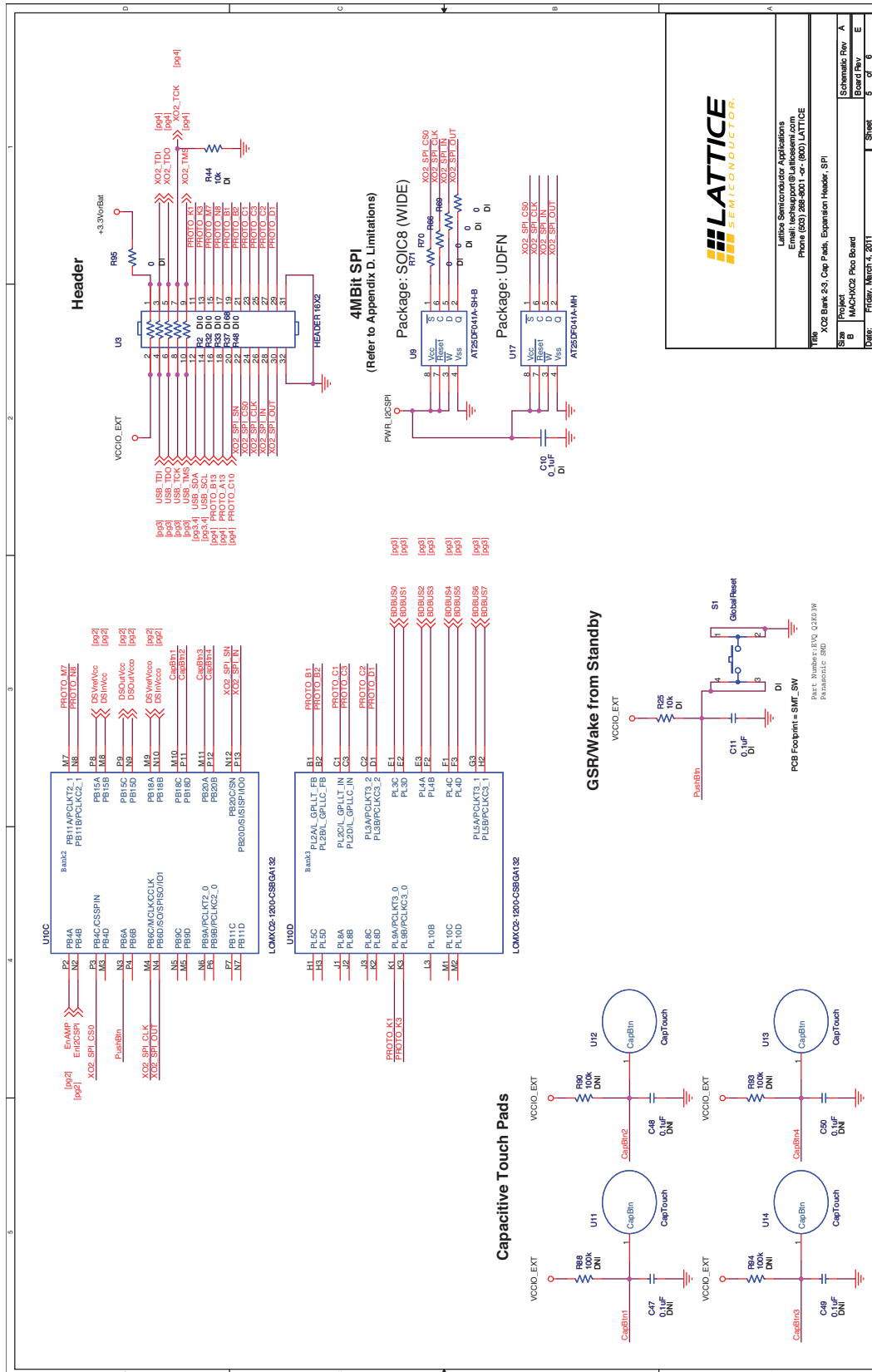
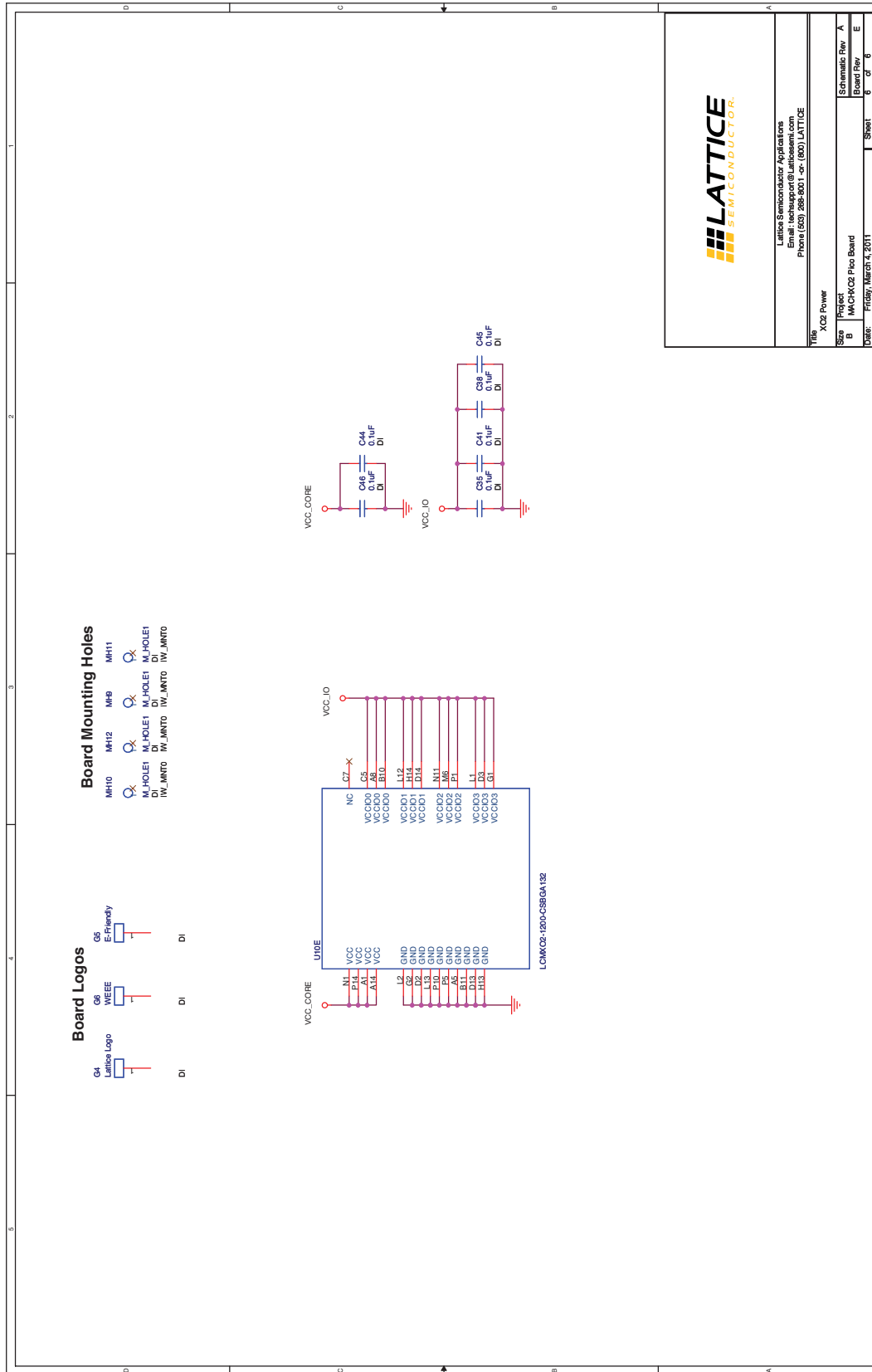

Figure 13. MachXO2 Power



## Appendix B. Bill of Materials

| Item | Quantity | Reference   | Part              | Footprint             | Populate | Vendor                          | Part Number       | Description                      |
|------|----------|---|-------------------|-----------------------|----------|---------------------------------|-------------------|----------------------------------|
| 1    | 2        | C10,C20   | 0_1uF             | SM/C_0603             | DI       | Panasonic                       | ECJ-1VB1C104K     | 0.1uF surface mount cap          |
| 2    | 3        | C1,C2,C21   | 1uF               | SM/C_0603             | DI       | Panasonic                       | ECJ-2YB1A105K     | 1uF surface mount cap            |
| 3    | 2        | C5,C6   | 10nF              | SM/C_0603             | DI       | Panasonic ECG                   | ECJ-1VB1C104K     | 10nF SMC                         |
| 4    | 1        | J1  | USB_MINI_B        | TYPE_B                | DI       | Hirose                          | UX60-MB-5ST       | USBType-BMiniConnector           |
| 5    | 35       | R2,R8,R11,R13,R14,R15,R16,R17,R20,R21,R22,R23,R31,R32,R33,R34,R35,R40,R43,R47,R48,R49,R55,R56,R64,R65,R66,R69,R70,R71,R75,R89,R95,R96,R97 | 0                 | SM/R_0603             | DI       | Panasonic ECG                   | ERJ-3GEY0R00V     | Resistor 0.0 SMD 0603            |
| 6    | 5        | R50,R58,R60,R79,R92   | 1k                | SM/R_0603             | DI       | Vishay/Dale                     | CRCW06031K00FKEA  | Resistor 1k SMD 0603             |
| 7    | 8        | R1,R3,R4,R25,R27,R29,R44,R78  | 10k               | SM/R_0603             | DI       | Vishay/Dale                     | CRCW060310K0FKEA  | 10K 0603 SMT resistor            |
| 8    | 1        | R59   | 10k               | SM/R_0603             | DNI      | Vishay/Dale                     | CRCW060310K0FKEA  | 10K 0603 SMT resistor            |
| 9    | 1        | U1  | M93C46-WMN6TP     | SOIC-8                | DI       | STMicroelectronics              | M93C46-WMN6TP     | IC 1K EEPROM 8-SOIC              |
| 10   | 1        | U5  | TMP101            | SM/SOT23_6            | DI       | TI                              | TMP101NA/250      | IC TEMP SENSOR DIG SOT-23-6      |
| 11   | 1        | R19   | 1M                | SM/R_0603             | DI       | PanasonicECG                    | ERJ-3GEYJ105V     | RES 1.0M1/10W5%                  |
| 12   | 1        | R53   | 1M                | SM/R_0603             | DNI      | PanasonicECG                    | ERJ-3GEYJ105V     | RES 1.0M1/10W5%                  |
| 13   | 1        | U17   | AT25DF041A-MH     | UDFN                  | DNI      | Atmel                           | AT25DF041A-MH     | IC FLASH 4MBIT 70MHZ 8SOIC       |
| 14   | 4        | MH9,MH10,MH11,MH12  | M_HOLE1           | IW_MNT0               | DI       | 3M                              | SJ-5003 (BLACK)   | BUMPON HEMISPHERE .44X.20 BLACK  |
| 15   | 6        | R38,R42,R46,R51,R57,R61   | 2k                | SM/R_0603             | DI       | Susumu Co Ltd                   | RG1608P-202-B-T5  | RES 2.0K OHM 1/10W .1% 0603 SMD  |
| 16   | 1        | BT1   | Batt_Cell_Holder  | BA2032_Battery_Holder | DI       | Linx Technologies Inc           | BAT-HLD-001       | HOLDER BATTERY 20MM COIN CR2032  |
| 17   | 16       | C3,C9,C11,C12,C24,C25,C26,C35,C38,C41,C44,C45,C46,C54,C57,C58   | 0.1uF             | SM/C_0603             | DI       | TDK Corporation                 | C1608X7R1E104K    | CAP CER .10UF 25V X7R 10% 0603   |
| 18   | 4        | C47,C48,C49,C50   | 0.1uF             | SM/C_0603             | DNI      | TDK Corporation                 | C1608X7R1E104K    | CAP CER .10UF 25V X7R 10% 0603   |
| 19   | 12       | C28,C29,C31,C32,C33,C34,C36,C37,C39,C40,C42,C43   | 0.01uF            | SM/C_0603             | DI       | TDK Corporation                 | C1608X7R1H103K    | CAP CER 10000PF 50V X7R 10% 0603 |
| 20   | 1        | C23   | 0.33uF            | SM/C_0603             | DI       | TDK Corporation                 | C1608X7R1A334K    | CAP CER .33UF 10V X7R 0603       |
| 21   | 1        | C7  | 6.8uF             | SM/C_1206             | DI       | AVX Corporation                 | TAJA685K020RNJ    | CAP TANTALUM 6.8UF 20V 10% SMD   |
| 22   | 1        | C8  | 10uF              | SM/C_0805             | DI       | Nichicon                        | TAJA685K020RNJ    | CAP TANTALUM 10UF 6.3V 20% SMD   |
| 23   | 1        | D2  | Blue              | SM/D_0603             | DI       | Lite-On Inc                     | LTST-C190TBKT     | LED 468NM BLUE CLEAR 0603 SMD    |
| 24   | 1        | L1  | Ferrite_bead      | SM/R_0603             | DI       | Laird-Signal Integrity Products | MI0603J600R-00    | FERRITE 1A 60 OHM 0603 SMD       |
| 25   | 1        | U2  | MCP1703T-1202E/CB | SOT-23A-3             | DI       | Microchip Technology            | MCP1703T-1202E/CB | IC REG LDO 1.2V 200MA SOT-23A    |
| 26   | 3        | R5,R7,R28   | 100k              | SM/R_0603             | DI       | Panasonic - ECG                 | ERJ-3GEYJ104V     | RES 100K OHM 1/10W 5% 0603 SMD   |
| 27   | 4        | R88,R90,R93,R94   | 100k              | SM/R_0603             | DNI      | Panasonic - ECG                 | ERJ-3GEYJ104V     | RES 100K OHM 1/10W 5% 0603 SMD   |
| 28   | 1        | R54   | 4.7k              | SM/R_0603             | DI       | Panasonic - ECG                 | ERJ-3EKF4701V     | RES 4.70K OHM 1/10W 1% 0603 SMD  |
| 29   | 2        | R26,R30   | 2.2k              | SM/R_0603             | DI       | Panasonic - ECG                 | ERJ-3GEYJ222V     | RES 2.2K OHM 1/10W 5% 0603 SMD   |
| 30   | 4        | R39,R41,R45,R52   | 50                | SM/R_0603             | DI       | Vishay/Dale                     | TNPW060349R9BEEA  | RES 49.9 OHM 1/10W 0.1% 0603     |
| 31   | 2        | R81,R91   | 500               | SM/R_0603             | DI       | Panasonic - ECG                 | ERJ-3EKF4990V     | RES 499 OHM 1/10W 1% 0603 SMD    |



| Item | Quantity | Reference                                       | Part                 | Footprint                  | Populate | Vendor                           | Part Number          | Description   |
|------|----------|---|----------------------|----------------------------|----------|----------------------------------|----------------------|---|
| 32   | 1        | R98   | 12k                  | SM/R_0603                  | DI       | Panasonic - ECG                  | ERA-3AEB123V         | RES 12K OHM 1/10W .1% 0603 SMD                      |
| 33   | 3        | Q1,Q3,Q4  | IRLML6402PbF         | SM/SOT23_123               | DI       | International Rectifier          | IRLML6402TRPBF       | MOSFET P-CH 20V 3.7A SOT-23                         |
| 34   | 1        | Q2  | IRF240               | SM/SOT23_123               | DI       | International Rectifier          | IRLML2502TRPBF       | MOSFET N-CH 20V 4.2A SOT-23                         |
| 35   | 1        | S1  | GlobalReset          | SMT_SW                     | DI       | Panasonic - ECG                  | EVQ-Q2K03W           | SWITCH LT 6MM 130GF H=3.1MM SMD                     |
| 36   | 1        | U8  | NCP1117              | SOT-223_checkpins          | DI       | STMicroelectronics               | NCP1117ST33T3G       | IC REG LDO 1A 3.3V SOT223                           |
| 37   | 1        | U3  | HEADER 16X2          | Header16x2                 | DNI      | Samtec Inc                       | TLW-108-06-G-D       | CONN HEADER .100" 16POS DL GOLD                     |
| 38   | 2        | C19,C30   | 0.047uF              | SM/C_0603                  | DI       | TDK Corporation                  | C1608X7R1H473K       | CAP CER 47000PF 50V X7R 10% 0603                    |
| 39   | 2        | R18,R85   |                      | 1 SM/R_0603                | DI       | Vishay/Dale                      | CRCW06031R00FKEA     | RES 1.00 OHM 1/10W 1% 0603 SMD                      |
| 40   | 1        | D3  | NSR0530P2T5G         | SM/SOD_923                 | DNI      | ON Semiconductor                 | NSR0530P2T5G         | DIODE SCHOTTKY 30V 0.5A SOD-923                     |
| 41   | 1        | R24   |                      | 20 SM/R_0603               | DNI      | Panasonic - ECG                  | ERJ-3GEYJ200V        | RES 20 OHM 1/10W 5% 0603 SMD                        |
| 42   | 2        | R80,R84   | 3.3k                 | SM/R_0603                  | DI       | Rohm Semiconductor               | MCR03EZPJ332         | RES 3.3K OHM 1/10W 5% 0603 SMD                      |
| 43   | 1        | R36   | 3.3k                 | SM/R_0603                  | DNI      | Rohm Semiconductor               | MCR03EZPJ332         | RES 3.3K OHM 1/10W 5% 0603 SMD                      |
| 44   | 1        | U10   | LCMXO2-1200-CSBGA132 | CSBGA132                   | DI       | Lattice                          | LCMXO2-1200-CSBGA132 | LCMXO2-1200-CSBGA132                                |
| 45   | 1        | U7  | LCD-S401M16KR        | LCD-S401M16KR              | DI       | Lumex Opto/Components Inc        | LCD-S401M16KR        | LCD custom order from phil@duerfeldtengineering.com |
| 46   | 12       | R62,R63,R67,R68,R72,R74,R76,R77,R82,R83,R86,R87 | 5.49k                | SM/R_0603                  | DI       | Panasonic - ECG                  | ERJ-3EKF5491V        | RES 5.49K OHM 1/10W 1% 0603 SMD                     |
| 47   | 1        | R37   |                      | 68 SM/R_0603               | DI       | Panasonic - ECG                  | ERJ-3GEYJ680V        | RES 68 OHM 1/10W 5% 0603 SMD                        |
| 48   | 2        | C55,C56   | 18pF                 | SM/C_0603                  | DI       | TDK Corporation                  | C1608C0G1H180J       | CAP CER 18PF 50V C0G 5% 0603                        |
| 49   | 1        | C51   | 3.3uF                | SM/C_0603                  | DI       | TDK Corporation                  | C1608X5R0J335K       | CAP CER 3.3UF 6.3V X5R 0603                         |
| 50   | 1        | C13   | 4.7uF                | SM/C_0603                  | DI       | TDK Corporation                  | C1608X5R0J475K       | CAP CER 4.7UF 6.3V X5R 0603                         |
| 51   | 1        | L3  | 600ohm 500mA         | FB0603                     | DI       | Murata Electronics North America | BLM18AG601SN1D       | FERRITE CHIP 600 OHM 500MA 0603                     |
| 52   | 1        | U23   | FT2232HL             | tqfp64_0p5_12p2 x12p2_h1p6 | DI       | Future                           | FT2232H R            | USB UART/FIFO                                       |
| 53   | 1        | X3  | 12MHZ                | crystal_4p_3p2x2 p5        | DI       | TXC CORPORATION                  | 7M-12.000MAAJ-T      | CRYSTAL 12.000 MHZ 18PF SMD                         |
| 54   | 3        | U20,U21,U22                                     | STG3693QTR           | QFN                        | DI       | STMicroelectronics               | STG3693QTR           | IC SWITCH QUAD SPDT 16QFN                           |
| 55   | 1        | U15   | LMP7708              | MSOP                       | DI       | STMicroelectronics               | LMP7708MM/NOPB       | IC AMP PREC R-R OUT DUAL 8-MSOP                     |
| 56   | 2        | C22,C27   | 220pF                | SM/C_0603                  | DI       | TDK Corporation                  | C1608X7R1H221K       | CAP CER 220PF 50V X7R 10% 0603                      |
| 57   | 1        | U9  | AT25DF041A-SH-B      | AT25DF041A-SOIC-8          | DI       | Atmel                            | AT25DF041A-SH-B      | IC FLASH 4MBIT 70MHZ 8SOIC                          |
| 58   | 1        | G4  | Lattice Logo         | LOGO300_1000               | DI       |                                  |                      |   |
| 59   | 1        | G5  | E-Friendly           | EFRIENDLY_400_SM           | DI       |                                  |                      |   |
| 60   | 1        | G6  | WEEE                 | WEEE_SM                    | DI       |                                  |                      |   |
| 61   | 4        | TP1,TP2,TP3,TP4                                 | TP                   | LOGO300_1000               | DI       |                                  |                      |   |
| 62   | 4        | U11,U12,U13,U14                                 | CapTouch             | CapTouch                   |          |                                  |                      |   |

## Appendix C. SPI Programming

- In order to support SPI programming of the MachXO2 device the zero ohm resistors (R71, R70, R66, R69) will have to be removed
- Once removed, the SPI programming pins can be accessed via the header U3 (XO2\_SPI\_OUT, XO2\_SPI\_IN, XO2\_SPI\_CLK, XO2\_SPI\_SN)
  - Programming is supported using Diamond Programmer\ispVM or using an external processor
  - As defined in [“Appendix E. Limitations” on page 21](#) the signal XO2\_SPI\_CLK is recommended to have a 1K Ohm pull up to VCC\_IO

## Appendix D. Dual Boot Demonstration

You can demonstrate MachXO2 dual boot using the MachXO2 Pico Evaluation Board.

Before you start you will need to do the following:

1. Create a SVF file to erase only the Configuration Flash and UFM memory. Do NOT erase the Feature Row.
  - a. Use ispVM or Diamond Programmer to create a SVF file with the which erases the device as a base-line.
  - b. Modify your SVF to change the following:
    - ! Shift in ISC ERASE(0x0E) instruction
    - SIR 8 TDI (0E);
    - SDR 8 TDI (0C); ! Change from E=1110 to C=1100 no Feature Row
  - c. For more information on the Feature Row, refer to TN1204, [MachXO2 Programming and Configuration Usage Guide](#).
2. Update the MachXO2 Pico Demo to enable dual boot.
  - a. Using Diamond in the Spreadsheet View, Global Preference tab set MASTER\_SPI\_PORT=ENABLE.
3. Power-on the SPI memory on the MachXO2 Pico Evaluation Board.
  - a. This is a low power board and if something is not used it is powered down. This can done by shorting the south side of C25 and R97 by soldering or holding a probe on them as they are beside each other. For reference, the north side of the board has the header U3. Shorting these components provides sets the mux U21 select high powering up the SPI device.
  - b. For more information, refer to the board schematics in “[Appendix A. Schematic](#)” on page 10.
4. As defined in “[Appendix E. Limitations](#)” on page 21 the signal XO2\_SPI\_CLK is recommended to have a 1K Ohm pull up to VCC\_IO.

**Figure 14. MachXO2 Pico Evaluation Board SPI/I<sup>2</sup>C Bus Power Enable**

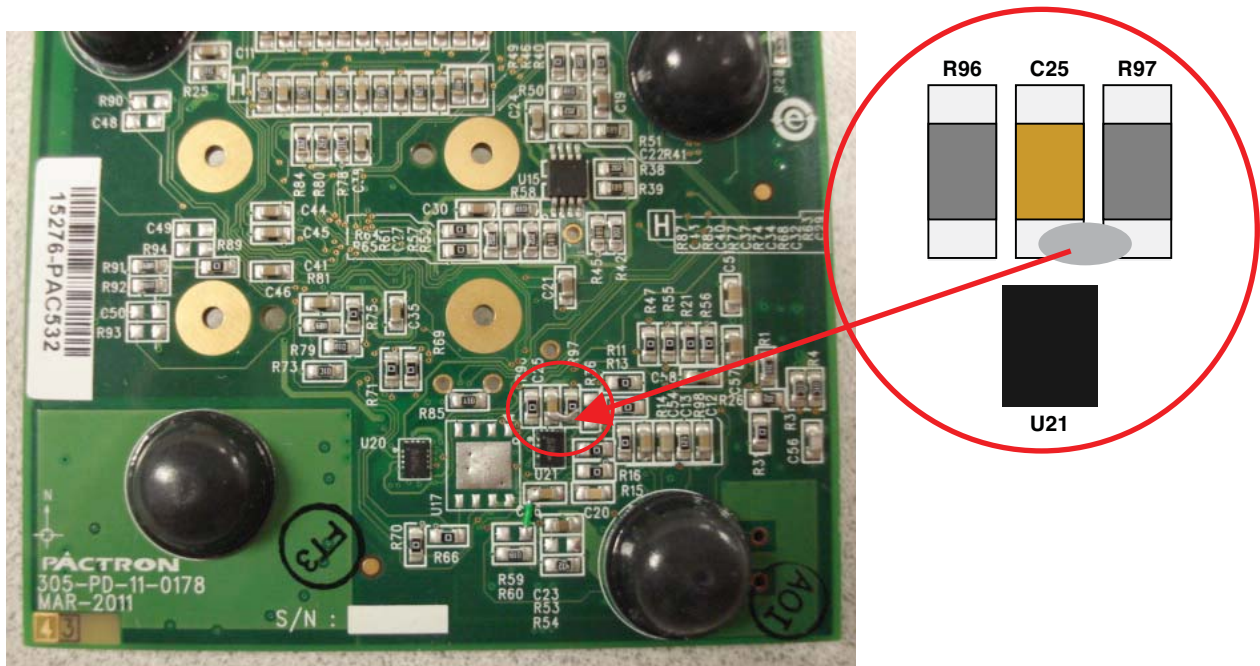

## Demonstrating Dual Boot

1. Program the MachXO2 device with the modified Pico Demo.
  - a. Select the operation Flash Erase, Program, Verify.
  - b. "PICO" will display on the LCD showing that it is running.
2. Program the SPI Flash (SPI-AT25DF041A) on the board with the modified Pico Demo.
  - a. Using ispVM or Diamond Programmer the SPI Flash can be programmed with the SPI Flash Programming option.
  - b. As defined in TN1204, [MachXO2 Programming and Configuration Usage Guide](#), the starting address must be 0x010000.
3. Reprogram the MachXO2 device with the modified Pico Demo as the Feature Row was erased when the SPI was programmed.
4. Erase the MachXO2 Flash (and not the Feature Row) using the modified SVF file.
5. Power cycle and watch dual boot in action as the MachXO2 loads the image from the SPI into the SRAM.
  - a. "PICO" will display on the LCD showing that it is running.
  - b. The Flash can be read back, confirming that the SRAM image came from the SPI memory.

## Appendix E. Limitations

- Pin A7 USB\_12MHz clock should be an input unless R31 is removed to ensure FTDI device operation
- Pin B9 JTAGENB is not connected on the board
- It is recommended to have a 1K Ohm pull up on MachXO2 pin MCLK (signal XO2\_SPI\_CLK)