

Product	IGBT	Package	TO-252
---------	------	---------	--------

1.Scope

This specification covers the tape packing requirements for TO-252.

For individual diodes the applicable specification shall be referred to.

2.Components description

Unit:mm

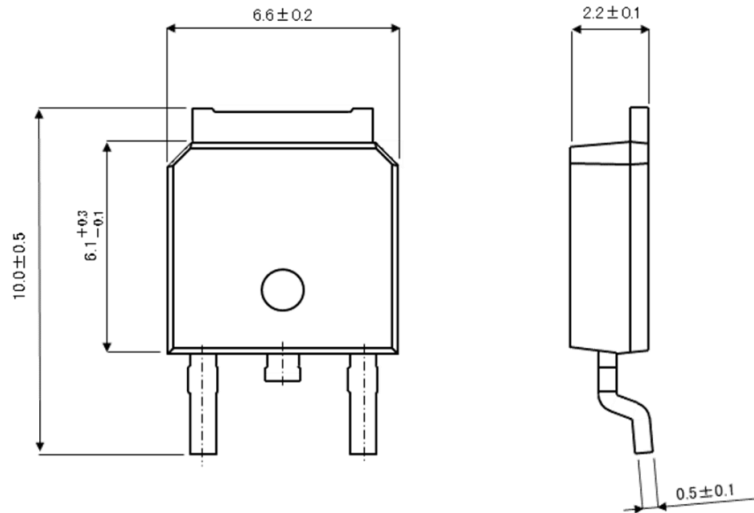

Note) The applicable specification describes in detail for individual SiC.

This figure is only for reference.

3.Taping dimensions

Unit:mm

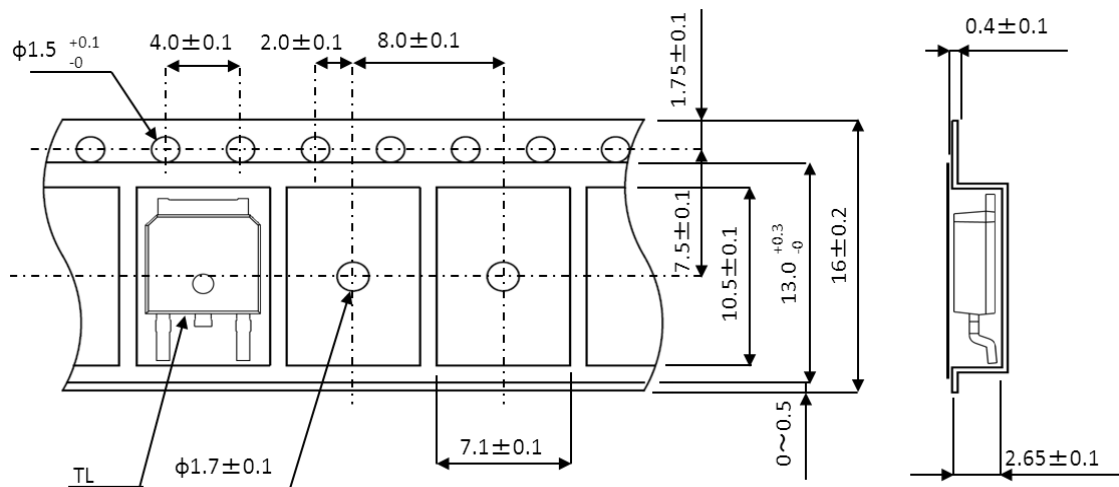

Note) Feed holes might be cover with the adhesive tape, but nothing will affect for using by that.

Packing

4. Taping packaging specification

4-1 Direction of tape winding.

TL Connection collector fin come to feeding hole side. The direction shall be one in a reel.

4-2 Cumulative pitch tolerance.

The cumulative pitch tolerance of the mold for producing the carrier tape shall be within 0.2mm per 10 pitches.

4-3 The minimum radius to bend the carrier tape.

Carrier tape shall be flexible enough to protect from no component and damage under a minimum radius. However, it shall be defined only inside of carrier tape.

4-4 The material of carrier tape.

Polystyrene.

5. Reel dimensions

Unit:mm

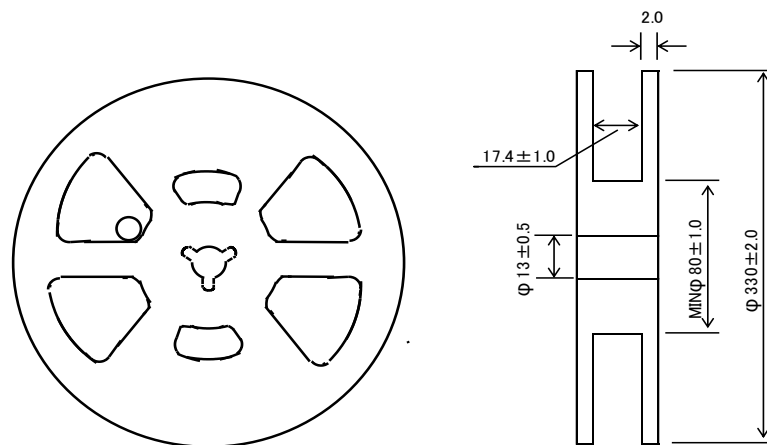

6. Reeling specificati

6-1 Leading direction

Leading direction of carrier tape shall be indicated as below.

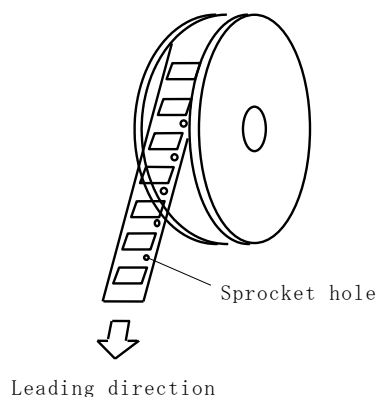

6-2 Leader Unit:mm

Leader tape shall be separated into two parts.

(adhesive tape at first part and carrier tape without products)

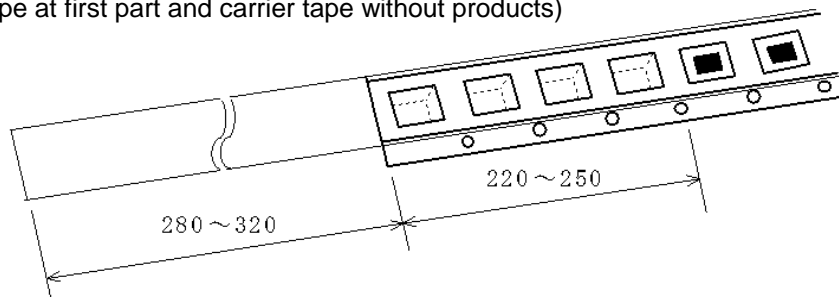

6-3 Trail Unit:mm

Trail tape shall remain with no product and trail tape shall not be stuck directly on a reel.

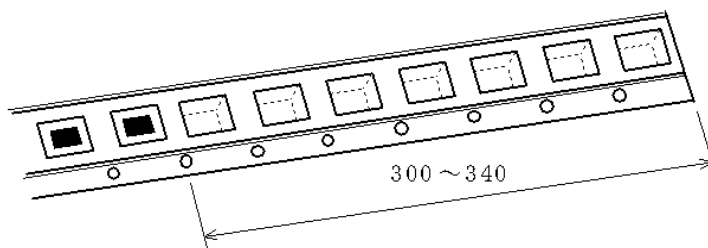

7.Type Product code of taping shall be composed as indicated below.

Ex: RFE10BM3S TL
Type code Taping code

8.Quantity Quantity per one reel is 2,500pcs.

9. Marking Each reel shall be legibly marked with the following items.

- 1.Type
- 2.Quantity
- 3.Lot No.
- 4.Inspector No.
- 5.Trademark ✕Bar codes are also displayed, too.

10.Package The reel shall be packed in the paper case or plastic case.