

PART NUMBER	REV	FIRST USED
466266-1	C	122500-1
466266-2	A	565435-5

OBSELETE

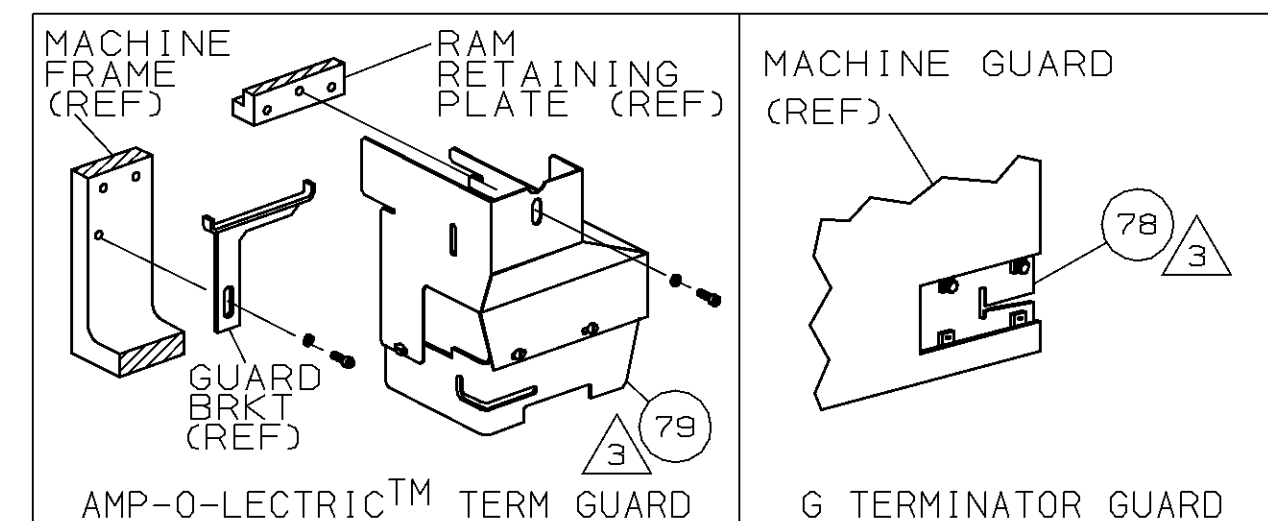

WIRE STRIP LENGTH		TERM APPL SPEC	FEED	APPL INSTRUCTION	SET UP GAGE	LAYOUT
-		114-2084	.570	408-8039	458638-1	262

PAD LTR		CRIMP HEIGHT		WIRE SIZE
A	.072 ±.002 [1.83 ±0.05mm]	16 OR 1.5mm <sup>2</sup>		
B	.070 ±.002 [1.78 ±0.05mm]	1.0mm <sup>2</sup>		
C	.066 ±.002 [1.68 ±0.05mm]	18 OR 0.8mm <sup>2</sup>		
D	.062 ±.002 [1.57 ±0.05mm]	20 OR 0.5mm <sup>2</sup>		

CRIMP	SIZE	TYPE	RANGE
WIRE	.100 [2.54mm]	F	20-16 & 0.5-1.5mm <sup>2</sup>
INSUL	-	-	-

LEADMAKER & BENCH MODEL G		MECH POST FEED				
REF	REF	-	A	22594-8	NUT, HEX	70
REF	REF	-	B	240628-1	PLATE, ADJ	69
REF	REF	-	B	240626-1	SHAFT, PIVOT	68
REF	REF	-	B	240633-1	BUSHING	67
REF	REF	-	A	455680-1	LEVER, INTERMEDIATE	66
REF	REF	-	B	240629-1	BLOCK, PIVOT	65
REF	REF	-	A	240632-2	SCR, ADJ	64
REF	REF	-	B	240659-3	PIN, CAM ROLLER	63
REF	REF	-	B	240658-1	CAM, ROLLER	62
REF	REF	-	B	454398-1	ROD, FEED	61

THIS DRAWING IS A CONTROLLED DOCUMENT FOR AMP INCORPORATED. IT IS SUBJECT TO CHANGE AND THE CONTROLLING ENGINEERING ORGANIZATION SHOULD BE CONTACTED FOR THE LATEST REVISION.

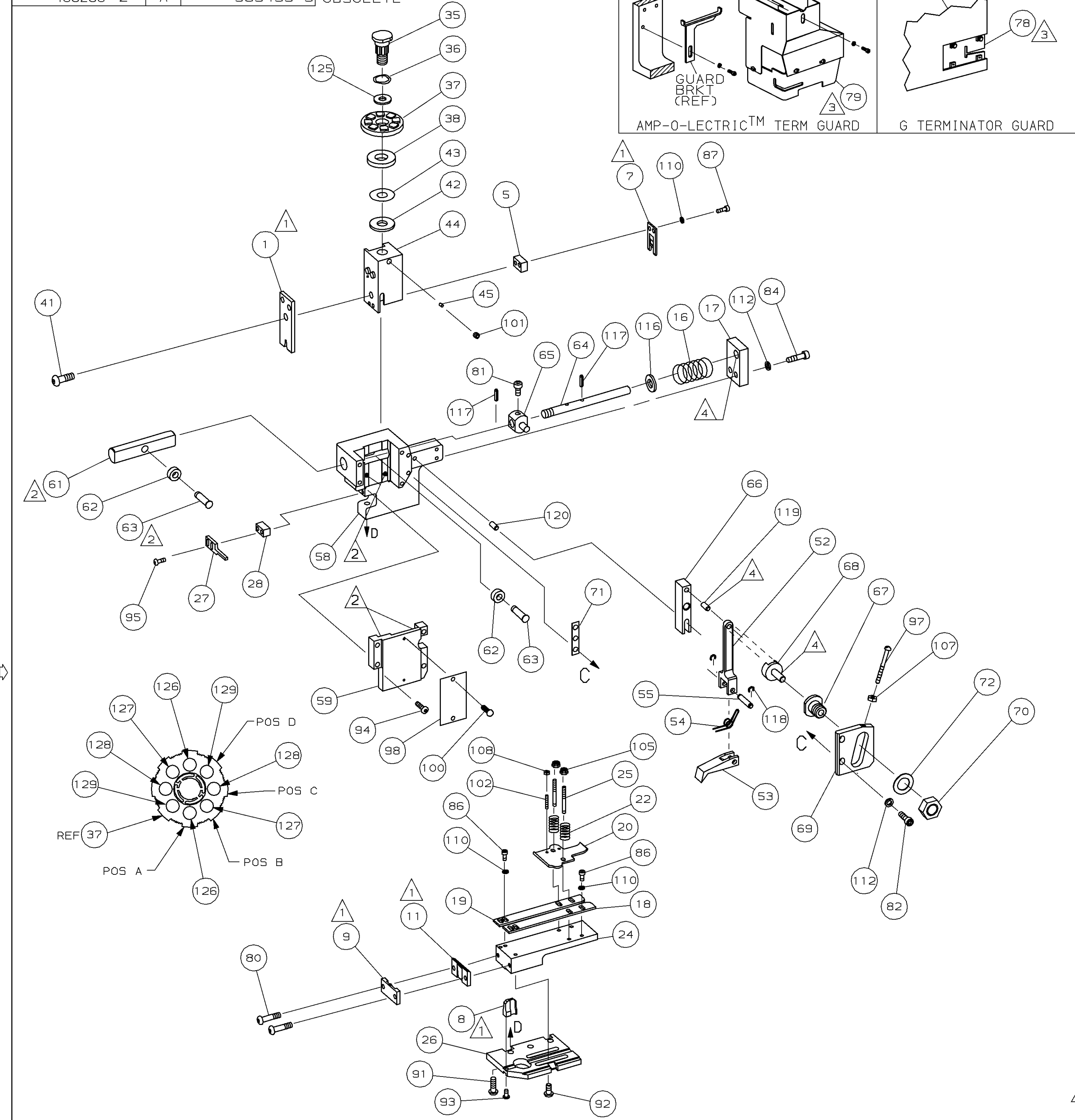

QTY	REF	REV	TER	DESCRIPTION	ITEM NO	
2	2	-	C	9-354778-7	PIN, WIRE DISC (.2980)D	129
2	2	-	C	8-354778-9	PIN, WIRE DISC (.2940)C	128
2	2	-	C	8-354778-1	PIN, WIRE DISC (.2900)B	127
2	2	-	C	7-354778-7	PIN, WIRE DISC (.2880)A	126
1	1	-	A	986950-1	WASHER, FLAT PRECISION	125
1	1	-	A	217238-1	GENERAL INSTRUCTION PACKAGE	124
1	1	-	-	4088039	EF APPL INST 408-8039	123
						122
						121
REF	REF	-	A	1-21030-7	PIN, DOWEL (Ø.187x1.50)HSG	120
REF	REF	-	A	1-21030-1	PIN, DOWEL (Ø.187x.50)LEVER	119
REF	REF	-	A	21045-3	RING, RET "C" (Ø.187)FD PIN	118
REF	REF	-	A	5-21028-1	PIN, STD SPRING (Ø.12)FD ADJ ROD	117
REF	REF	-	A	21899-4	WASHER, FLAT (Ø5/16)SCR ADJ	116
						115
						114
						113
REF	REF	-	A	21024-5	WASHER, LOCK (NO.10)FD ROD GDE	112
6	6	-	A	21024-4	WASHER, LOCK (NO.8)SHEAR BL	110
						109
2	2	-	A	21018-4	NUT, HEX (4-40)DRAG	108
REF	REF	-	A	21018-5	NUT, HEX (6-32)FD ADJ PL	107
						106
2	2	-	A	21022-2	NUT, HEX SL (8-32)DRAG STUD	105
						104
						103
2	2	-	A	2-21006-6	SCR, SKT SET (4-40x.62)DRAG	102
1	1	-	A	21009-2	SCR, SKT SET (1/4-20x.25 )RAM	101
2	2	-	A	21017-2	SCR, DRIVE (#2x.19) ID PLATE	100
1	1	-	A	1-21002-7	SCR, BHC (6-32x.38)CAM	99
1	1	-	B	461264-1	PLATE, IDENTIFICATION	98
REF	REF	-	A	6-23715-5	SCR, PAN HD (6-32x1.50)FEED ADJ	97
						96
2	2	-	A	2-21002-2	SCR, BHC (8-32x.50)STRIPPER	95
REF	REF	-	A	2-21002-9	SCR, BHC (10-32x.75)HSG CAP	94
1	1	-	A	22733-8	SCR, BHC (8-32x.38 LW)ANVIL	93
4	4	-	A	3-21002-3	SCR, BHC (1/4-20x.50)ST GD PL	92
REF	REF	-	A	2-22733-8	SCR, BHC (1/4-20x.62)BASE PL	91
						90
						89
						88
2	2	-	A	2-21000-6	SCR, SHC (8-32x.38)SLUG BLADE	87
4	4	-	A	7-21000-4	SCR, SHC (8-32x.31)STRIP GUIDE	86
						85
REF	REF	-	A	3-21000-7	SCR, SHC (10-32x.75)FEED ROD GDE	84
						83
REF	REF	-	A	3-21000-6	SCR, SHC (10-32x.62)FEED ADJ PL	82
REF	REF	-	A	3-21000-4	SCR, SHC (10-32x.38)PIVOT BLOCK	81
2	2	-	A	3-21002-0	SCR, BHC (10-32x.88)SHEAR PL	80
REF	-	-	A	455745-1	GUARD, WINDOW	79
-	REF	-	A	679532-1	INSERT, GUARD	78
						77
						76
						75
						74
						73
REF	REF	-	A	458109-1	WASHER, FLAT (SPECIAL)	72
REF	REF	-	A	690517-1	SPACER	71

QTY	REF	REV	TER	DESCRIPTION	ITEM NO	
					60	
REF	REF	-	C	454220-1	CAP, RAM	59
REF	REF	-	D	453736-1	HOUSING	58
					57	
					56	
REF	REF	-	B	240624-1	PIN, FEED FINGER	55
REF	REF	-	B	691499-1	SPRING, FEED FINGER	54
REF	REF	-	B	240635-1	FINGER, FEED	53
REF	REF	-	B	240634-1	LEVER, TERMINAL	52
					51	
					50	
					49	
1	-	-	B	690501-3	CAM, POST FEED 1 1/8 ST	48
-	1	-	B	690501-4	CAM, POST-FEED 1 5/8 ST	47
					46	
1	1	-	A	690191-1	PLUG, NYLON	45
1	1	-	C	455674-1	RAM	44
1	1	-	A	690125-1	WASHER, LAMINATED	43
1	1	-	A	690124-1	WASHER, RAM	42
1	1	-	A	7-21002-9	BOLT, CRIMPER (5/16-24x1.00)	41
					40	
					39	
1	1	-	A	690223-2	SPACER, INSULATION DISC	38
1	1	-	D	354777-1	WIRE DISC, PLASTIC	37
1	1	-	A	22480-5	WASHER, SPRING	36
1	1	-	B	690212-1	POST, RAM	35
					34	
					33	
1	1	-	D	458980-1	APPLICATOR, BASIC (SUB ASSY)	32
					31	
					30	
					29	
1	1	-	B	3-690451-2	SPACER, STRIPPER	28
1	1	-	A	240639-1	STRIPPER	27
REF	REF	-	C	455676-1	PLATE, BASE	26
2	2	-	A	22354-8	DRAG, STUD	25
1	1	-	B	455678-1	PLATE, STRIP GUIDE	24
					23	
2	2	-	A	4-22281-1	SPRING, DRAG	22
					21	
1	1	-	A	454177-1	DRAG, STOCK	20
1	1	-	B	1-458030-4	GUIDE, STRIP (REAR)	19
1	1	-	C	1-458031-4	GUIDE, STRIP (FRONT)	18
REF	REF	-	A	454178-1	GUIDE, FEED ROD	17
REF	REF	-	A	4-22284-9	SPRING, FEED RETURN	16
					15	
					14	
					13	
					12	
1	1	-	B	240644-1	PLATE, REAR SHEAR	11
					10	
1	1	-	B	690482-6	PLATE, FRONT SHEAR	9
1	1	-	D	1-240654-5	ANVIL	8
1	1	-	B	690474-6	BLADE, SLUG	7
					6	
1	1	-	C	4-240641-2	SPACER, SLUG BLADE	5
					4	
					3	
					2	
1	1	-	C	456407-5	CRIMPER, WIRE	1

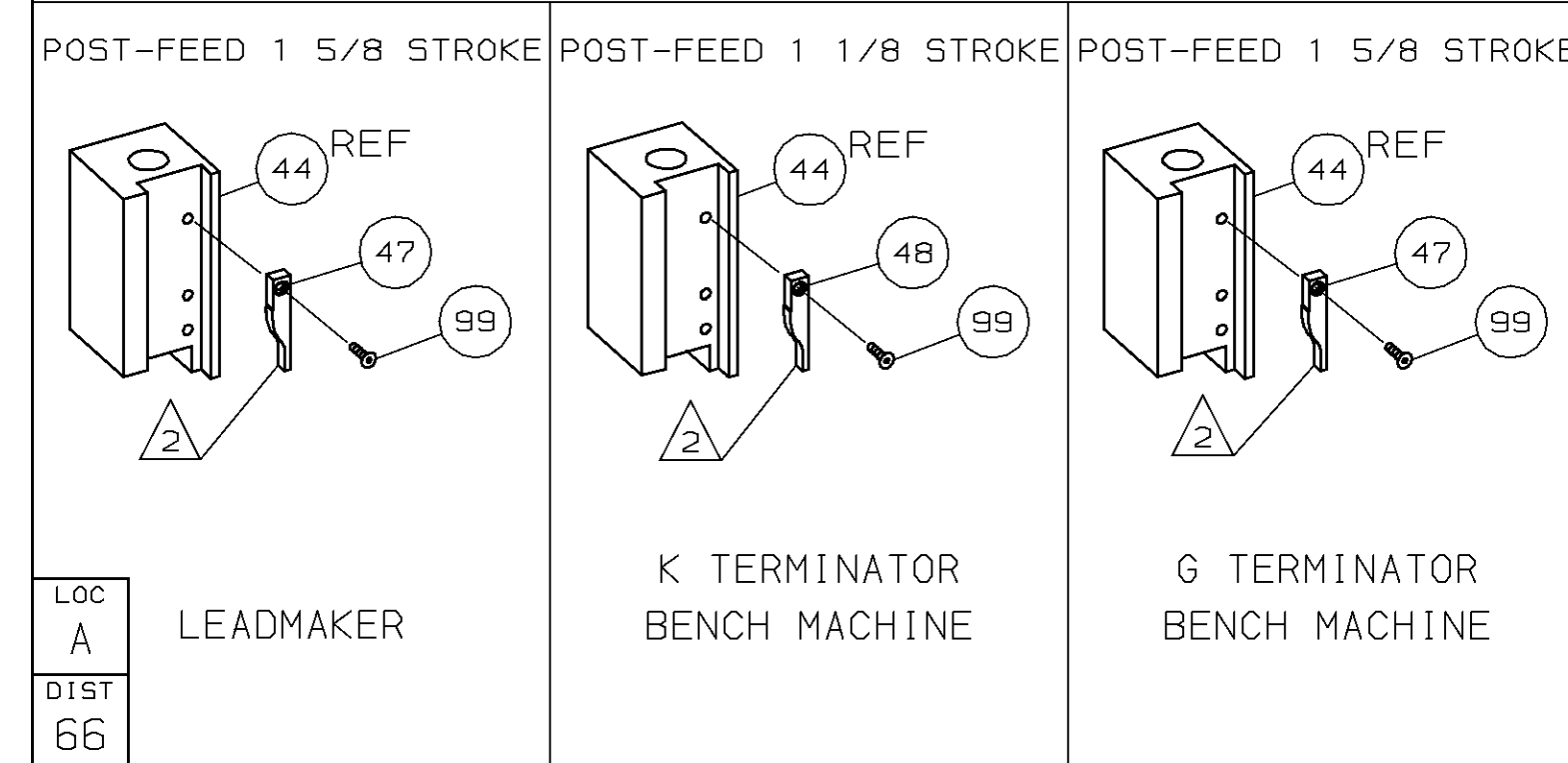

- 1 RECOMMENDED SPARE PARTS.
- 2 GREASE LIGHTLY.
- 3 GUARD MUST BE IN PLACE WHEN OPERATING APPLICATOR IN A BENCH MACHINE.
- 4 LUBRICATE DAILY USING NO. 20 MACHINE OIL.
- 5. ITEMS WITH QTY OF REF SPECIFIED (EXCEPT ITEMS 78 AND 79) ARE USED ON ITEM 32.
- 6 ITEM 78 USED WITH G TERMINATOR ONLY.

THIS INFORMATION IS CONFIDENTIAL AND IS DISCLOSED TO YOU ON CONDITION THAT NO FURTHER DISCLOSURE IS MADE BY YOU TO OTHER THAN AMP PERSONNEL WITHOUT WRITTEN AUTHORIZATION FROM AMP INCORPORATED, HARRISBURG, PA.

466266