

**PART NUMBER CODING**

**MATERIALS (INSULATOR / CONTACT)**

**R = BLACK PPS/PHOSPHOR BRONZE**

OPERATING TEMP: -65°C TO +125°C  
PROCESSING TEMP: 260°C MAX FOR 20 SECS

**G = BLACK PA9T/PHOSPHOR BRONZE**

OPERATING TEMP: -65°C TO +125°C  
PROCESSING TEMP: 260°C MAX FOR 20 SECS

**A = BLACK PPS/BERYLLIUM COPPER**

OPERATING TEMP: -65°C TO +150°C  
PROCESSING TEMP: 260°C MAX FOR 20 SECS

**J = BLACK PA9T/BERYLLIUM COPPER**

OPERATING TEMP: -65°C TO +150°C  
PROCESSING TEMP: 260°C MAX FOR 20 SECS  
(CONSULT FACTORY FOR OTHER MATERIALS)

**MODIFICATION**

OMIT = WITHOUT MOLDED KEY, EX: 'RBB15DHF'  
S# FOR MOLDED KEY  
(SEE DWG C13556 FOR S#, 'G' & 'H' DIMENSIONS)

**MOUNTING STYLE**

D = FLUSH MOUNTING (PAGE 1)  
N = NO MOUNTING EARS  
T = FLUSH MOUNTING WITH #4-40 THREADED INSERT  
R = BOARD LOCK

**NUMBER OF POSITIONS**  
(CONTACTS PER ROW)

**PLATING**

**ALL PLATINGS ARE LEAD FREE AND HAVE .000050" NICKEL UNDERPLATE**

CONTACT SURFACE      TERMINATION  
B = .000010" GOLD      .000100" PURE TIN, MATTE  
C = .000030" GOLD      .000100" PURE TIN, MATTE

REVISIONS				
REV.	ECO. NO	DESCRIPTION	DATE	BY
C	2098	REMOVED "-S621" FROM P/N CODING, PCB LAYOUT DIM .185" MAX (WAS .185" MIN), .315" MIN (WAS .315" MAX), CORRECT NOTES 8 & 9.	1/5/2010	JH
D	2919	ADD CONTACT GAP DIM, TOL TO INSULATOR WIDTH, UPDATE DWG FORMAT	2/13/2014	NC
E	4412	ADD MOLDED KEY OPTIONS	8/6/2021	PL

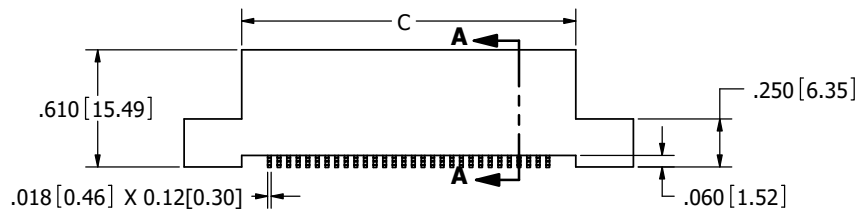
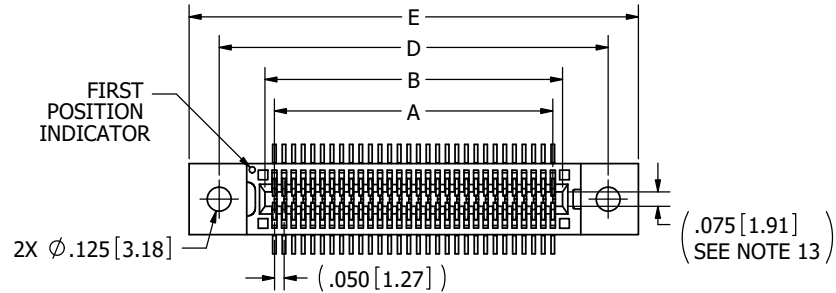
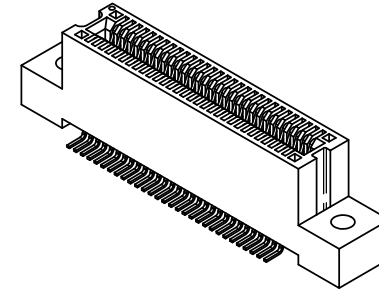

**\_\_B\_\_DHF**

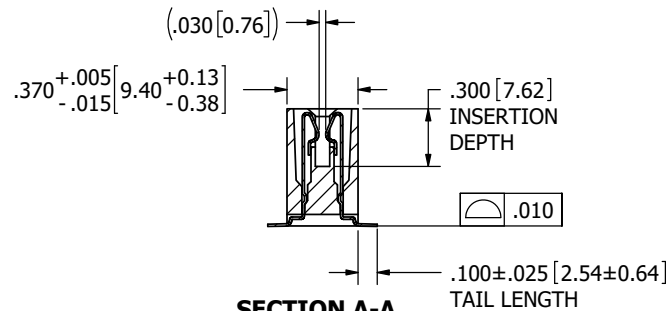

**SECTION A-A**

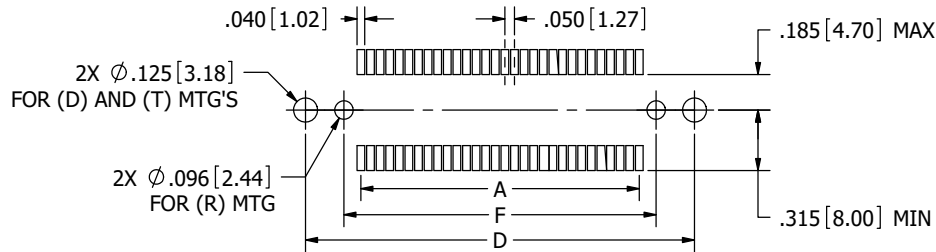

**RECOMMENDED PCB LAYOUT**

**NOTES:**

- INSULATOR MATERIAL: SEE PART NUMBER CODING
- CONTACT MATERIAL: SEE PART NUMBER CODING
- PLATING: SEE PART NUMBER CODING
- OPERATING TEMPERATURE: SEE PART NUMBER CODING
- PROCESSING TEMP: SEE PART NUMBER CODING
- UL FLAMMABILITY RATING: 94V-0
- OPERATING VOLTAGE: 300 VAC
- CURRENT RATING: 1 AMP
- CONTACT RESISTANCE: 30 MILLI OHMS MAX
- INSULATION RESISTANCE: 5000 MEGA OHMS
- DURABILITY: 500 CYCLES MIN
- CONNECTOR IDENTIFICATION: THE PART SHALL BE MARKED WITH A PART NUMBER AND LOT CODE
- BOARD THICKNESS ACCOMMODATED: .062 ± .008 [1.57 ± 0.20]
- INSERTION FORCE: 6 OZ MAX PER CONTACT PAIR WHEN USING A .062 [1.57] TEST BLADE
- INTERNAL INSPECTION TO BE PER SULLINS WORK INSTRUCTION WI-8.6-03
- WITHDRAWAL FORCE: 1/2 OZ MIN PER CONTACT PAIR USING .062 [1.57] PCB
- MODIFICATION: SEE PART NUMBER CODING



RoHS COMPLIANT

UNLESS OTHERWISE SPECIFIED:  
DIMENSIONS ARE IN INCHES (MM)

TOLERANCES:  
ANGULAR: ± 1°

DECIMALS  
.XX = ± .02 [5]  
.XXX = ± .005 [13]  
.XXXX = ± .0005 [013]

DRAWN	DATE	NAME
	4/28/2006	HT

THE INFORMATION HEREIN CONTAINS PROPRIETARY INFORMATION OF SULLINS ELECTRONICS AND IS NOT TO BE REPRODUCED, USED OR DISCLOSED TO OTHERS FOR ANY PURPOSE EXCEPT AS SPECIFICALLY AUTHORIZED IN WRITING BY AN OFFICER OF SULLINS ELECTRONICS.

		TITLE	
		EDGECARD, .050 CC, HP	
PART NUMBER		DWG. NO.	
__B__DHF-S		C10708	
SIZE	CAGE CODE	REV	
C	54453	E	
SCALE: 2:1		SHEET 1 OF 3	

**CUSTOMER COPY**

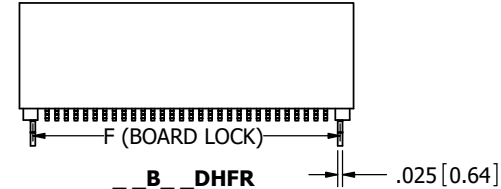
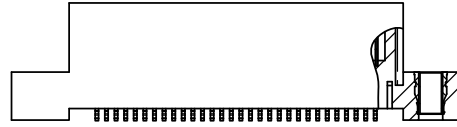
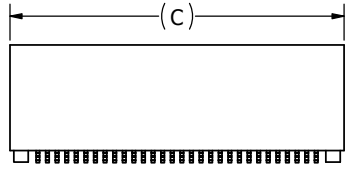
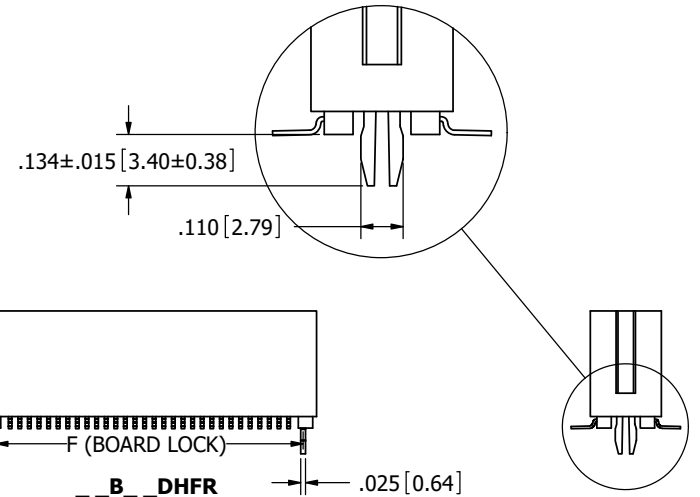
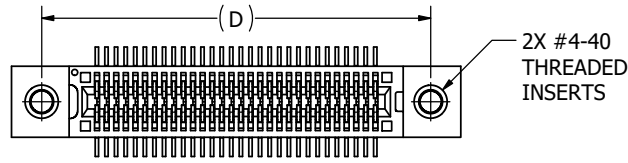
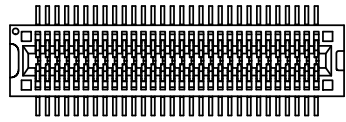

\_\_B\_\_ DHFN

\_\_B\_\_ DHFT

\_\_B\_\_ DHFR

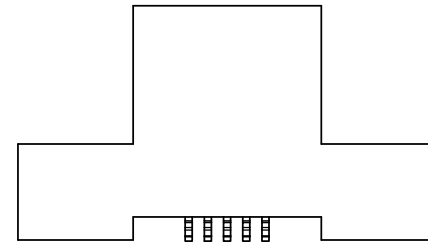
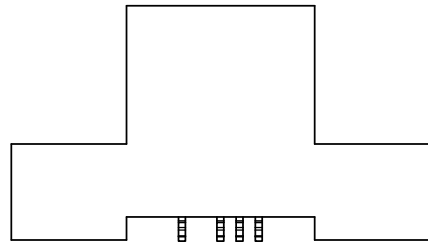
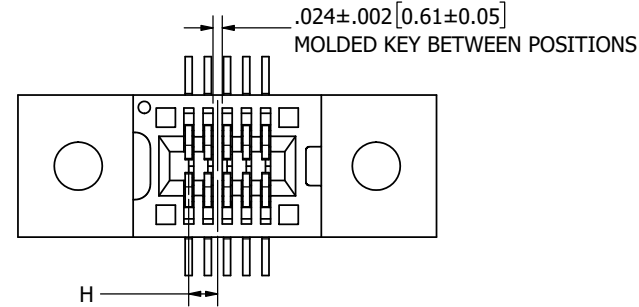
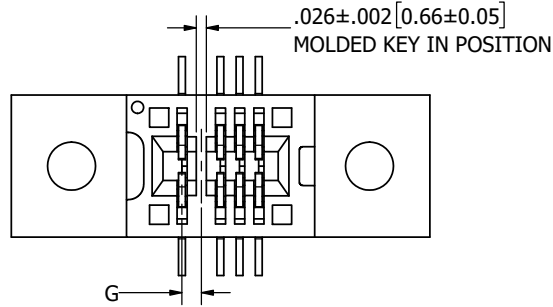

**MOLDED KEY IN POSITION**  
SCALE 4:1  
(‘D’ MOUNTING AS SHOWN FOR EXAMPLE)

**MOLDED KEY BETWEEN POSITIONS**  
SCALE 4:1  
(‘D’ MOUNTING AS SHOWN FOR EXAMPLE)

**CUSTOMER COPY**



RoHS COMPLIANT

UNLESS OTHERWISE SPECIFIED:  
DIMENSIONS ARE IN INCHES [MM]

TOLERANCES:  
ANGULAR: ± 1°  
DECIMALS  
.XX = ± .02 [5]  
.XXX = ± .005 [13]  
.XXXX = ± .0005 [013]

DRAWN	DATE	NAME
	4/28/2006	HT

THE INFORMATION HEREIN CONTAINS PROPRIETARY INFORMATION OF SULLINS ELECTRONICS AND IS NOT TO BE REPRODUCED, USED OR DISCLOSED TO OTHERS FOR ANY PURPOSE EXCEPT AS SPECIFICALLY AUTHORIZED IN WRITING BY AN OFFICER OF SULLINS ELECTRONICS.

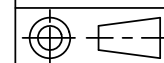

TITLE EDGE CARD, .050 CC, HP			
PART NUMBER __B__ DHF -S			
SIZE C	CAGE CODE 54453	DWG. NO. C10708	REV E
SCALE: 2:1		SHEET 2 OF 3	

