

■ Input-output condition

Item	Specification
Input voltage range	DC110~390V
Rated input voltage	DC140V, DC340V
Rated output voltage	3.3V
Rated load current	0.7A

■ Electrical specification Ta=25°C

Item	Specification	Conditions · Note
Efficiency	64% or more (70% TYP)	Rated input voltage Rated output current
Output voltage tolerance	+15% / -10%	Rated input voltage Output current 0~0.07A
	±10%	Rated input voltage Output current 0.07~0.7A
No-load power	50mW or less (15mW TYP)	Rated input voltage
Ripple	150mVp-p or less	Rated input voltage
Ripple noise	200mVp-p or less	Rated output current
Lower limit of output undershoot during load step	2.4V or more	Rated input voltage Output current 0⇔0.7A Slew rate 10uS
	2.8V or more	Rated input voltage Output current 0.07⇔0.7A Slew rate 10uS
Upper limit of output overshoot during load step	3.8V or less	Rated input voltage Slew rate 10uS

Measurement circuit

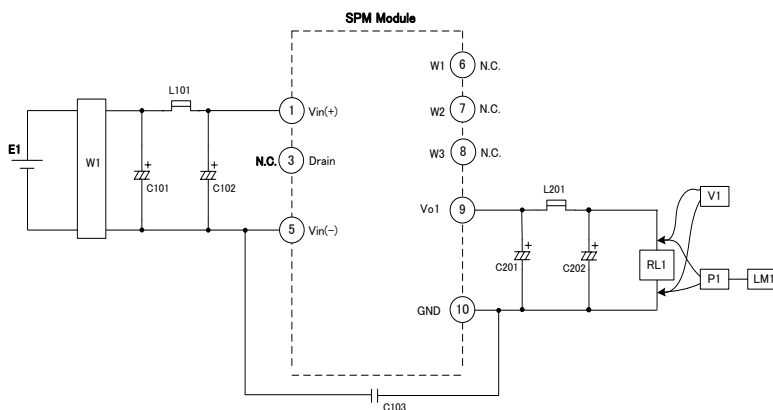

- E1 : DC power supply
- W1 : Wattmeter WT210 (YOKOGAWA)
- RL1 : Electronic load
- V1 : Voltmeter Class 0.5
- P1 : Differential probe DP-100 (KG)
- LM1 : Ripple noise meter RM-103 (KG)

- C101 : 450BXC6.8M (RUBYCON)
- C102 : 450BXC6.8M (RUBYCON)
- C103 : CD65ZU2GA681M (TDK)
- C201 : 10ZLG1200M (RUBYCON)
- C202 : 10ZLG1200M (RUBYCON)
- L101 : PJ5H-152M (KORIN)
- L201 : PJ5H-2R2M (KORIN)

Protection

Item	Specification	Conditions · Note
Overcurrent protection	0.74A or more	Auto recovery
Overheat protection		

Insulation

Item	Specification	Conditions · Note
Insulation voltage (Between Pri—Sec)	3.0kV (or 3.6kV)	AC 1min (or AC 2sec) Cutoff 2mA
Insulation resistance (Between Pri—Sec)	100M Ω or more	DC500V

Environmental conditions

Item	Specification	Conditions · Note
Operating temperature	-20°C~95°C	Refer to the ambient temperature derating
Operating humidity	20~95%RH (No condensation)	
Storage temperature	-25°C~100°C	
Storage humidity	5~95%RH (No condensation)	

Ambient temperature derating curve

Reduce the load current according to the following temperature derating table.

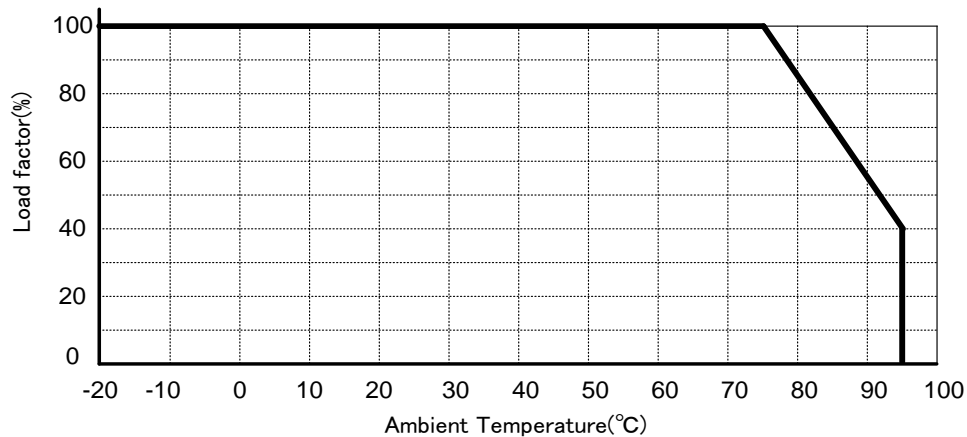

■ Typical characteristics Ta=25°C

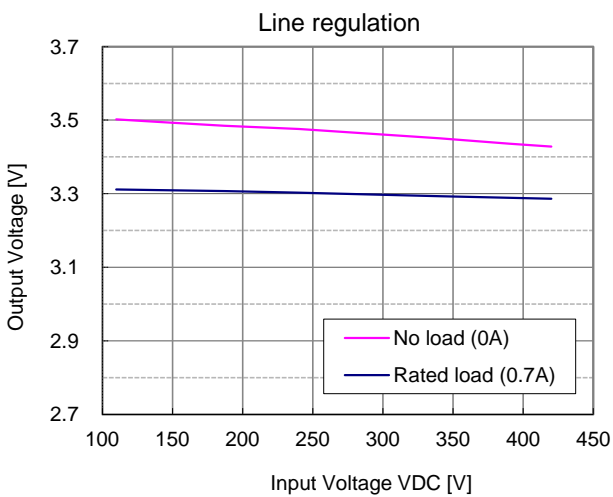
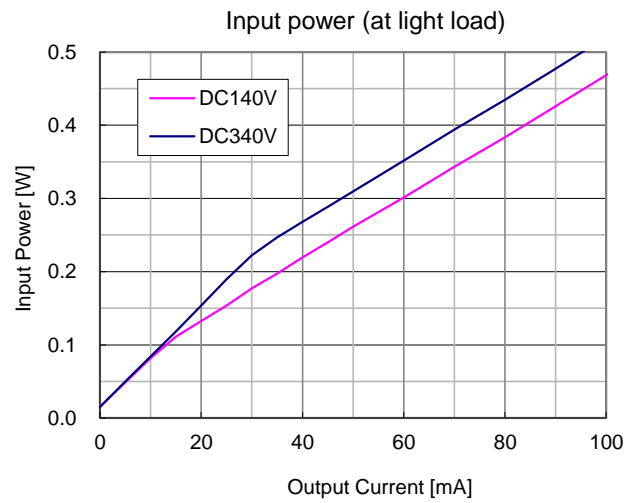
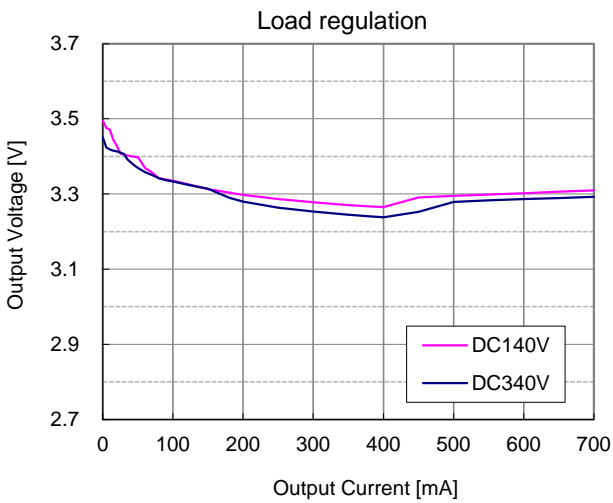
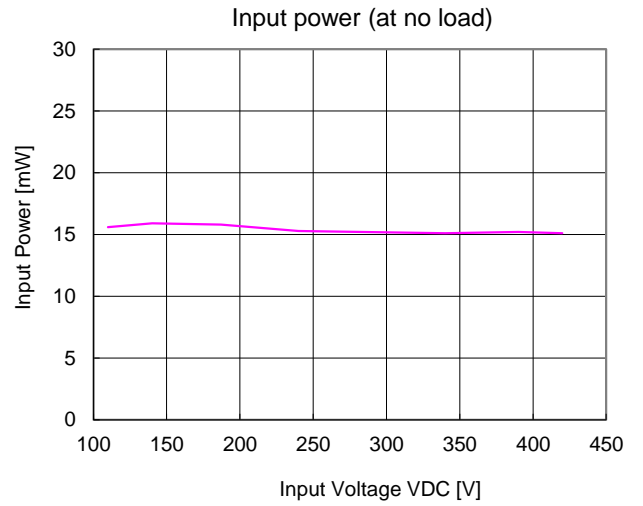
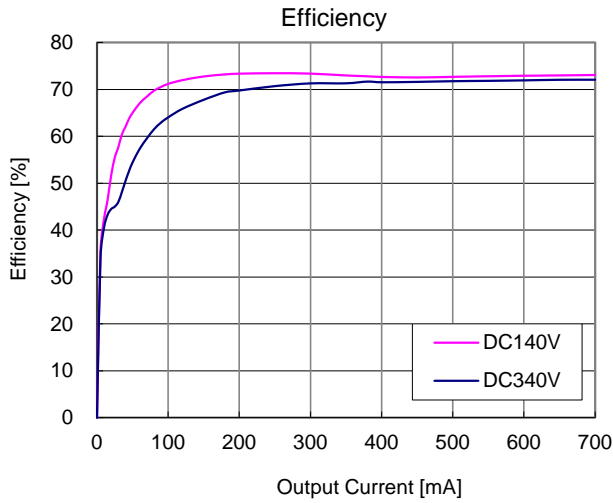

■Outline dimensional drawing

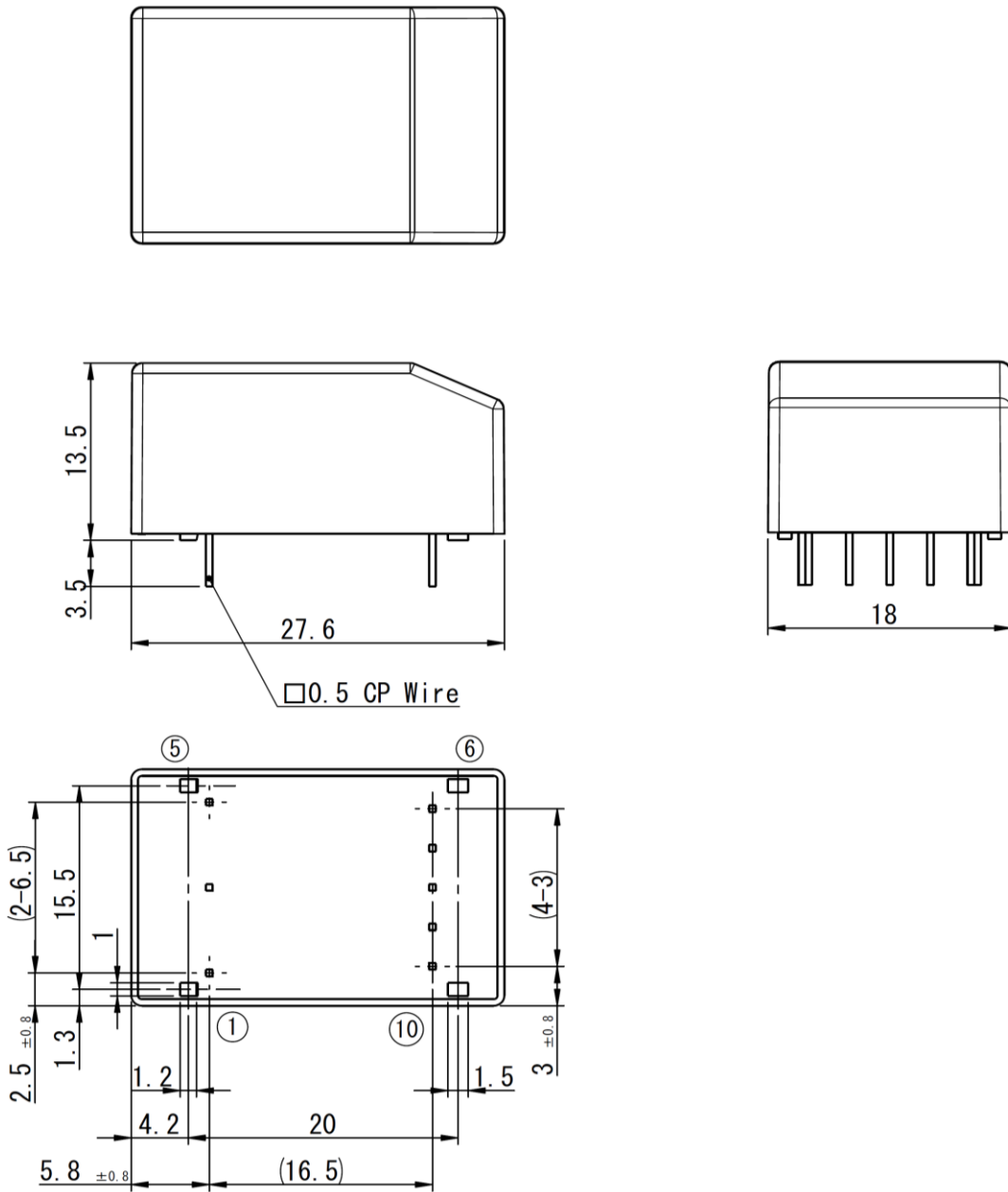

Note : 1. The dimensional tolerance without directions is ± 0.5 mm.

Unit : mm

■Recommended hole diameter and land size

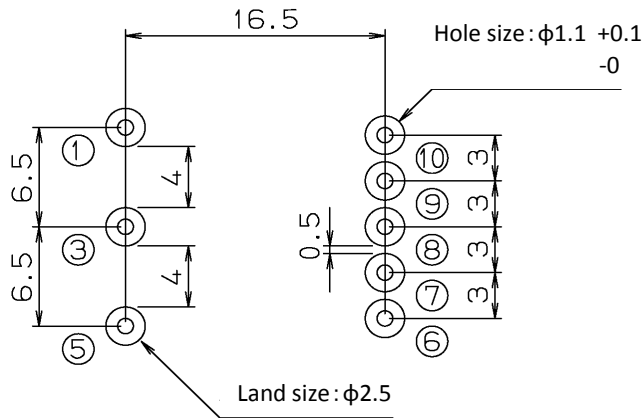

※ The round pulling out figure is a pin numbering.

Unit : mm

Component side

■Terminal function and connection

Primaries

Pin No.	Name	Explanation of terminals
1	Vin(+)	DC voltage input terminal (+)
2		No terminal
3	Drain	Terminal for noise adjustment
4		No terminal
5	Vin(-)	DC voltage input terminal (-)

Secondaries

Pin No.	Name	Explanation of terminals
6	W1	N. C.
7	W2	N. C.
8	W3	Secondary wired bundle pin ※Don't connect with other circuits.
9	Vo1	Output terminal (+)
10	GND	Output terminal (-)

■ Application circuit example

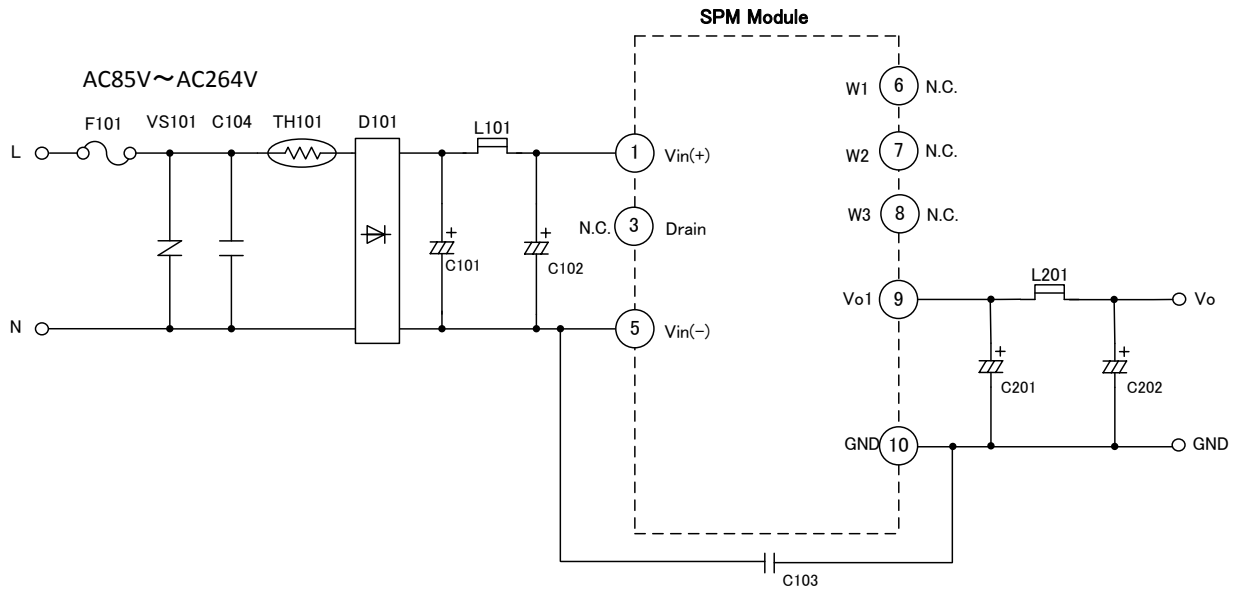

Symbol	Description	Part No.	Manufacturer
D101	Diode	S1NBC80	SHINDENGEN
TH101	Thermistor	NTPA7220L	MURATA
VS101	Varistor	TVR10471	THINKING
L101	Inductor	PJ5H-152M	KORIN
L201	Inductor	PJ5H-2R2M	KORIN
C101	Capacitor	400AX10M	RUBYCON
C102	Capacitor	400AX10M	RUBYCON
C103	Capacitor	CD65ZU2GA681M	TDK
C104	Capacitor	LE104-MX	OKAYA
C201	Capacitor	10ZLG1200M	RUBYCON
C202	Capacitor	10ZLG1200M	RUBYCON
F101	Fuse	FIH 250V 2.5A	NIPPON-SEISEN

※Mount the fuse on the input Live side to ensure safety without fail.
 Recommended parts : FIH 250V 1.6A~2.5A/NIPPON-SEISEN

※Depend on the applying safety standard, please add the discharge resistance in paralell with C104.