

ZWS-B Series

ZWS10B · ZWS15B · ZWS30B

Instruction Manual

BEFORE USING THE POWER SUPPLY UNIT

Be sure to read this instruction manual thoroughly before using this product. Pay attention to all cautions and warnings before using this product. Incorrect usage could lead to an electrical shock, damage to the unit or a fire hazard.

DANGER

Never use this product in locations where flammable gas or ignitable substances are present. There are risks of igniting these substances and exploding by an arcing.

WARNING



- Do not touch this product or its internal components while circuit is live, or shortly after shut down. There may be high voltage or high temperature present and you may receive an electric shock or burn.
- When this product is operating, keep your hands and face away from it as you may be injured by an unexpected situation.
- Do not make unauthorized changes to this product, otherwise you may receive an electric shock and void your warranty.
- Do not drop or insert anything into this product. It might cause a failure, fire and electric shock.
- Do not use this product under unusual condition such as emission of smoke or abnormal smell and sound etc. It might lead to fire and electric shock. In such cases, please contact us. Do not attempt repair by yourself, as it is dangerous for the user.
- Do not operate these products in the presence of condensation. It might lead fire or electric shock.

CAUTION

- This power supply is designed and manufactured for use within an end product such that it is accessible to SERVICE ENGINEERS only.
- Confirm connections to input/output terminals are correct as indicated in the instruction manual before switching on.
- Input voltage, Output current, Output power, ambient temperature and ambient humidity should be kept within specifications, otherwise the product will be damaged.
- Do not operate and store this product in an environment where condensation might occur. In such case, waterproof treatment is necessary.
- Do not use this product in environment with a strong electromagnetic field, corrosive gas or conductive substances.
- For applications, which require very high reliability (Nuclear related equipment, medical equipment, traffic control equipment, etc.), it is necessary to provide a fail-safe mechanism in the end equipment.
- Do not inject abnormal voltages into the output of this product. The injection of reverse voltage or over voltage exceeding nominal output voltage into the output terminal might cause damage to internal components.
- Never operate the product under over current or short-circuit conditions for more than 30 seconds, or outside its specified Input Voltage Range. Insulation failure, smoking, burning or other damage may occur.
- This product contains a printed circuit board utilizing surface mounted devices. PCB stress such as bending, twisting etc. could cause damage. Therefore, please handle with care.
- When handling this product, hold the board edge and take care not to touch the component side. When installing this product in apparatus or equipment, mount it on spacers.
- The outputs of this product may, under fault conditions, exceed SELV voltage limits. Therefore the outputs must be earthed in the end equipment to maintain SELV. If the outputs are not earthed, they must be considered hazardous and must not be made user accessible.
- This product has used Power Thermistor to protect the circuit from Inrush Current. Frequent repetition of input on/off might cause damage to internal components because of generating surge current.
- Breaking of internal fuse is considered internal failure. In such cases, please contact us.
- The information in this document is subject to change without prior notice. Please refer to the latest version of the data sheet, etc., for the most up-to date specifications of the product.
- No part of this document may be copied or reproduced in any form without prior written consent of TDK-Lambda.

Note: CE MARKING

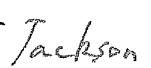
CE Marking when applied to a product covered by this handbook indicates compliance with the low voltage directive (2006/95/EC) as modified by the CE Marking Directive (2006/95/EC) in that it complies with EN60950-1.

DWG No.: CA790-04-01A		
APPD	CHK	DWG
 4-Jul-12	 4-Jul-12	 4-Jul-12

1. Model name identification method

ZWS 10 B – 5 / □

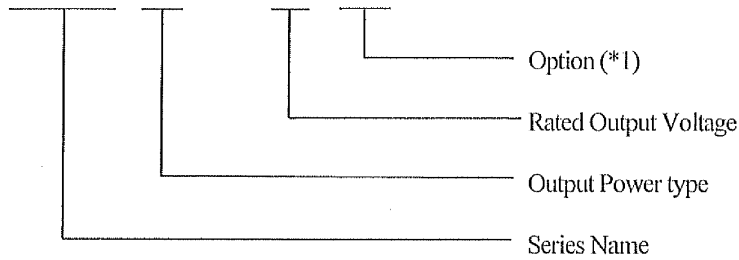

(*1)
Blank : Standard type.
/L : With chassis model.
/A : With chassis and cover model.

2. Terminal Explanation

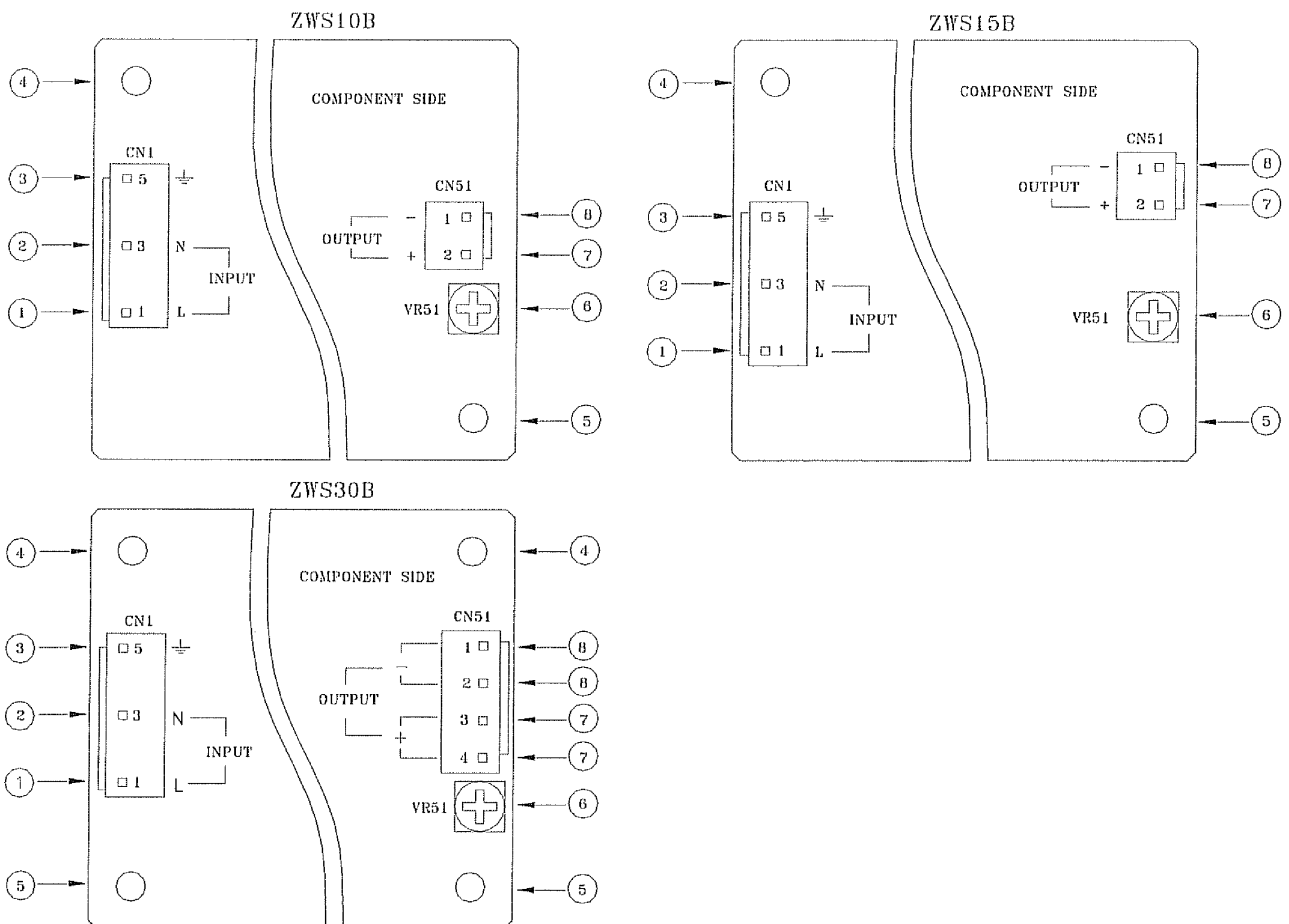

- ① L : AC Input terminal Live line (Fuse in line.)
- ② N : AC Input terminal Neutral line
- ③ \perp : \perp Terminal (Protective Earth)
- ④ Mounting hole (hole diameter : ϕ 3.5mm)
This hole is connected to Protective Earth of CN1.
Must be connected to electrically conductive spacer. The mounting surface of the spacer should be within Max ϕ 8mm.
- ⑤ Mounting hole (hole diameter : ϕ 3.5mm)
This hole is not connected to Protective Earth of CN1.
- ⑥ V.ADJ : Output voltage adjust trimmer. The output voltage rises when a trimmer is turned clockwise.
- ⑦ + : + Output Terminal
- ⑧ - : - Output Terminal

3. Terminal Connection Method

Pay attention to the input wiring. If it is connected to wrong terminal, the power supply will be damaged.

- Input must be off when making connections.
- Connect \perp terminal of input connector and mounting hole to protective earth of the equipment.
- The output load line and input line shall be separated to improve noise sensitivity.
- Do not apply stress to PCB, when connecting or removing connector.
- Do not apply stress to other components (especially VR51 and C51), when connecting or removing connector.
- Use input/output connector (housing) specified by the table below.
- Use recommended crimping tool. Connector is not included with this product. (Refer to the following)

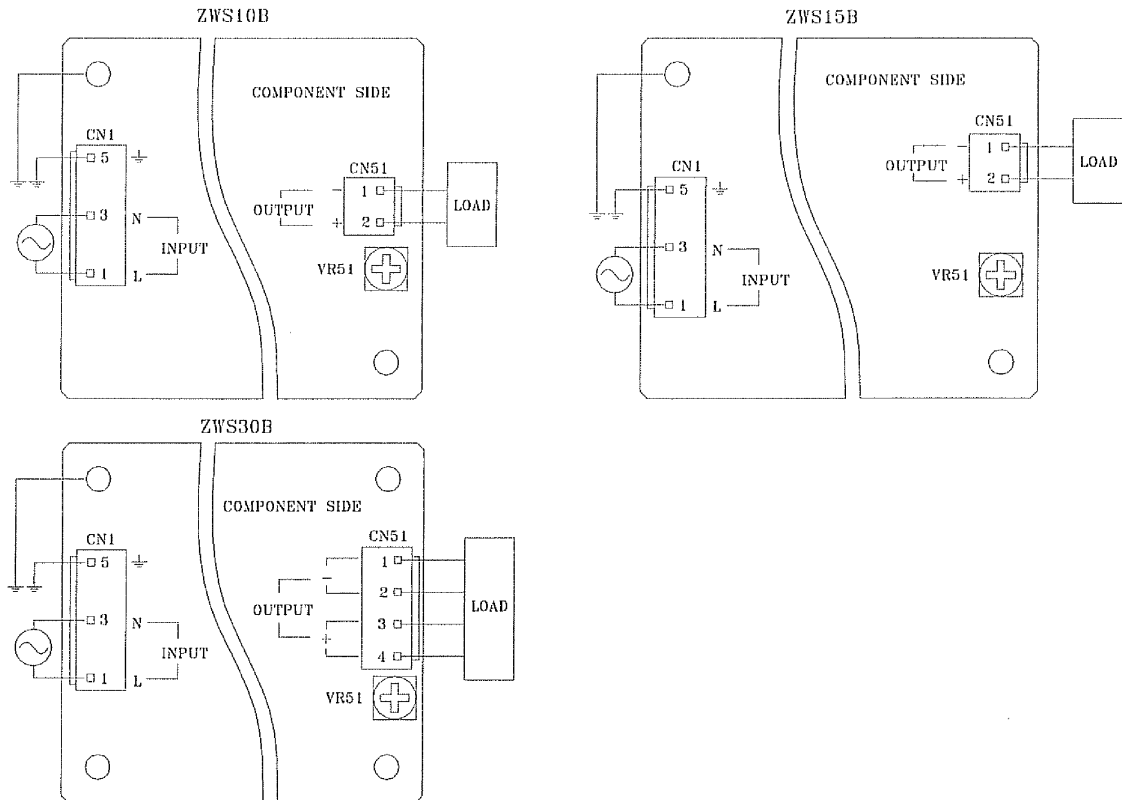

Input/Output Connector

	Model	Connector	Housing	Terminal Pin	Maker
Input (CN1)	Common	B3P5-VH(LF)(SN)	VHR-5N	SVH-21T-P1.1 BVH-21T-P1.1	J.S.T.
Output (CN51)	ZWS10B, ZWS15B	B2P-VH(LF)(SN)	VHR-2N		
Output (CN51)	ZWS30B	B4P-VH(LF)(SN)	VHR-4N		

Hand Crimping Tool : YC-160R (J.S.T.)

4. Explanation of Function and Precautions

4-1. Input Voltage Range

Input voltage range is single phase 85-265VAC (47-63Hz). Never operate the unit out of the specified input voltage range to avoid unit failure.

For cases where conformance to various safeties required, input voltage range will be 100-240VAC (50/60Hz).

4-2. Output Voltage Range

Output voltage is set the rated value at shipment. V.ADJ trimmer (VR51) can adjust the output voltage within the range. Output voltage range is within $\pm 10\%$ of nominal output voltage. To turn the trimmer clockwise, the output voltage will be increased. Take note when the output voltage is increased excessively, over voltage protection (OVP) function may trigger and voltage will be shut down. Furthermore, when increasing the output voltage reduce the output current so as not to exceed the maximum output power.

4-3. Inrush Current

This series equipped Power thermistor to limit the inrush current. Higher inrush current will flow at higher ambient temperature or re-input condition. Please select input switch and fuse carefully with the high temperature and re-input the power condition. The Inrush Current value is under cold start at 25°C in the specification.

4-4. Over Voltage Protection (OVP)

The OVP function (Inverter shut down method, manual reset type) is provided. Please refer to its specification for OVP operating range. When OVP trigger, the output will be shut down. To reset OVP, remove the input of power supply for a few minutes, and then re-input. In addition, the setting value of OVP is fixed and not adjustable. Pay attention not to apply higher voltage externally to the output terminal to avoid unit failure. In case of inductive load, put protective diode in series to the output power line.

4-5. Over Current Protection (OCP)

ZWS10B, ZWS15B, ZWS30B: Hiccup mode with automatic recovery.

OCP function operates when the output current exceeds 105% of maximum DC output current of specification. The outputs will be automatically recovered when the overload condition is canceled. Never operate the unit under over current or shorted conditions for more than 30seconds, which may leads damage or insulation failure. OCP setting is fixed and not to be adjusted externally.

4-6. Output Ripple & Noise

The standard specification for maximum ripple value is measured according to measurement circuit specified by JEITA-RC9131B. When load lines are longer, ripple will becomes larger. In this case, electrolytic capacitor, film capacitor, etc. might be necessary to use across the load terminal. The output ripple cannot be measured accurately if the probe ground lead of oscilloscope is too long. For start up at low ambient temperature and low input voltage, output ripple noise might not meet specification. However, output ripple noise specification can be met after one second.

A circuit reducing light load input power consumption is built in ZWS10B,ZWS15B,ZWS30B (Input power : 0.2W typ,0.5W max at no load). When output current is within 0-35% of rated load, the internal switch element is intermittent operated, and the switching loss is decreased. The specification of the Ripple & Noise changes by this intermittent operation. The dynamic load response characteristic changes by this intermittent operation too. Different input voltage and dynamic load condition has different dynamic load response characteristic. Please contact us for details.

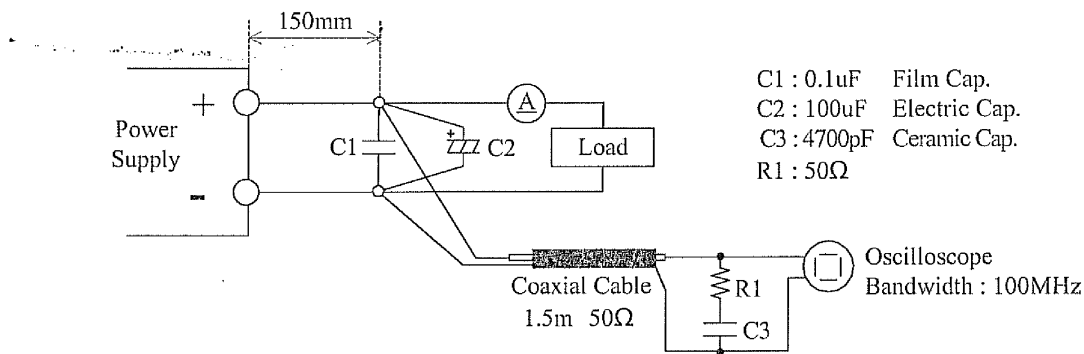

4-7. Series Operation

For series operation, either method (A) or (B) is possible.

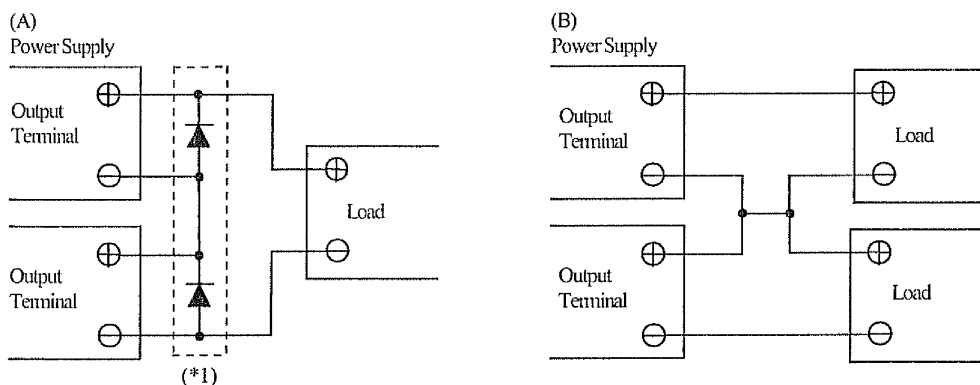

(*1) Please select a bypass diode with maximum forward current rating more than output load current. And maximum reverse voltage must withstand each power supply output voltage.

4-8. Parallel Operation

For parallel operation, method (B) is possible.

(A) To increase the output current is not possible.

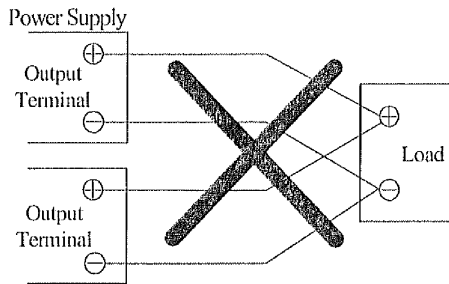

(B) To use as Back-up Power Supply

1. Adjust the output voltage of each power supply to be the same.
2. Set power supply output voltage higher by the forward voltage drop (V_f) of diode.

Use within the specification for output voltage and output power.

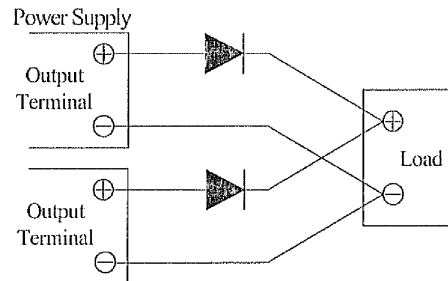

4-9. Isolation Test

Isolation resistance between Output and \perp (Protective Earth) is more than 100M Ω at 500VDC. For safety operation, voltage setting of DC isolation tester must be done before the test. Ensure that the unit is fully discharged after the test.

Output - \perp (Protective Earth) : 500VDC More than 100M Ω

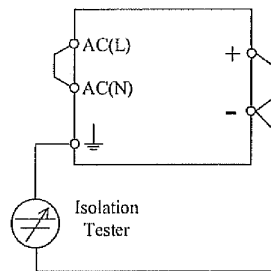

4-10. Withstand Voltage

This series is designed to withstand 3.0kVAC between input and output, 2.0kVAC between input and \perp (Protective Earth) and 500VAC between output and \perp (Protective Earth) each for 1 minute. When testing withstand voltage, set current limit of the withstand voltage test equipment to 10mA (output - \perp (Protective Earth): 20mA). The applied voltage must be gradually increased from zero to the testing value and then gradually decreased for shut down. When timer is used, the power supply may be damaged by high impulse voltage at timer switch on and off. Connect input and output as follows.

Input - Output (Dashed line) : 3.0kVAC 1min(10mA)

Input - \perp (Protective Earth) (Solid line) : 2.0kVAC 1min(10mA)

Output - \perp (Protective Earth) : 500VAC 1min(20mA)

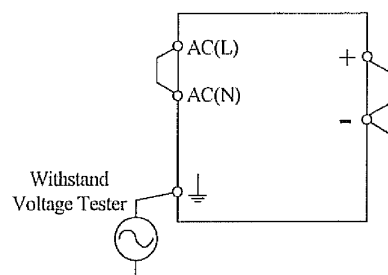
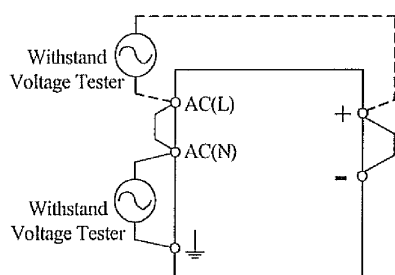

5. Mounting Directions

5-1. Output Derating according to the Mounting Directions.

Recommended standard mounting method is (A). Method (B)-(F) are also possible. Refer to the output derating below. Load(%) of derating curve indicates output power.

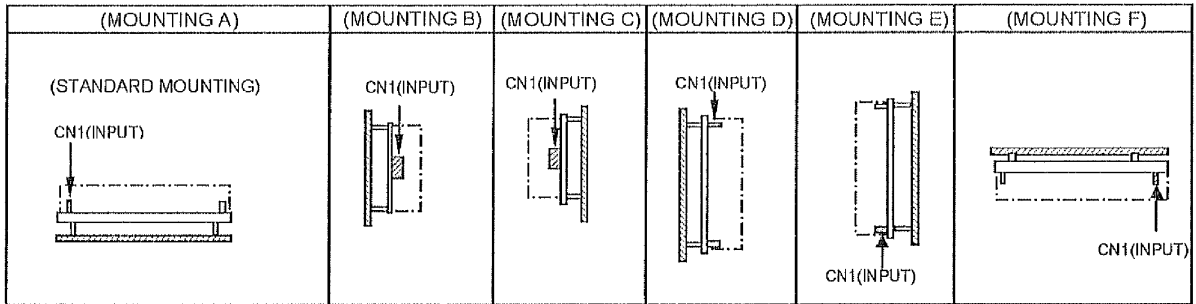

5-2. Output Derating vs Ambient temperature

Make sure that the specified temperature range is maintained. Operate the unit out of the specified derating curve may trigger OTP (IC integrated). When OTP trigger, the output will be shut down. To reset OTP, remove the input of power supply for a few minutes, wait until the unit cool down, and then re-input.

■ CONVECTION COOLING

ZWS10B

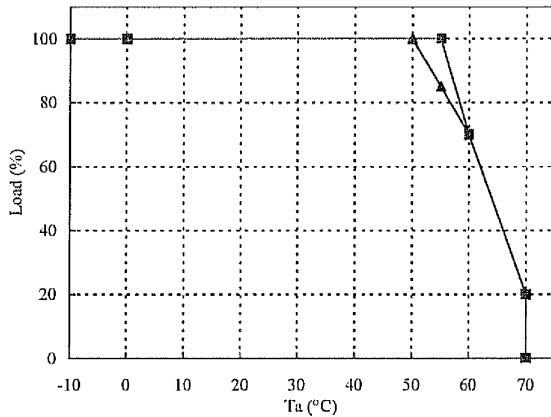

—■— Mounting (B),(C)
—▲— Mounting (A),(D),(E),(F)

Ta (°C)	Load (%)	
	Mounting (B),(C)	Mounting (A),(D),(E),(F)
-10~50	100	100
55	100	85
60	70	70
70	20	20

ZWS15B

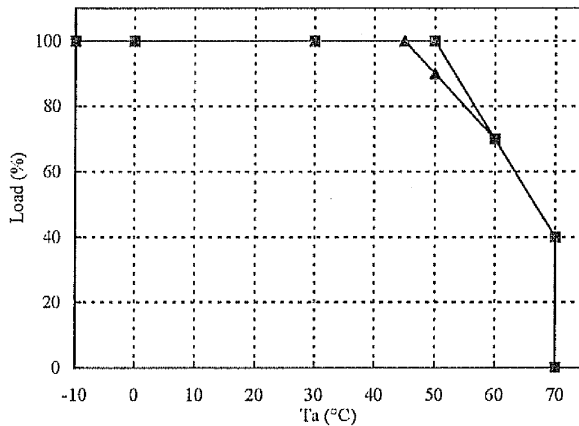

—■— Mounting (A), (B),(C),(D)
—▲— Mounting (E),(F)

Ta (°C)	Load (%)	
	Mounting (A)-(D)	Mounting (E),(F)
-10~45	100	100
50	100	90
60	70	70
70	40	40

ZWS30B

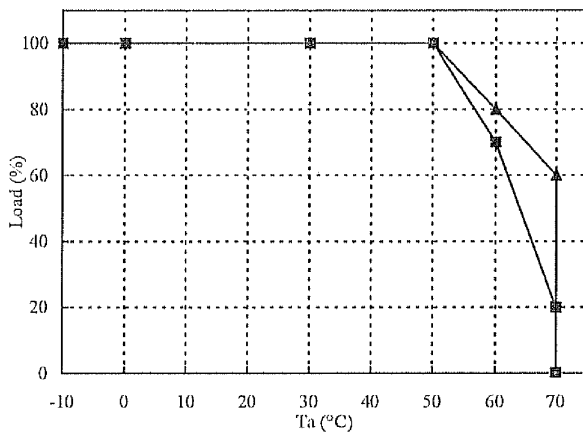

■ Mounting (A), (C),(D),(E),(F)
▲ Mounting (B)

Ta (°C)	Load (%)	
	Mounting (A),(C),(D),(E),(F)	Mounting (B)
-10~50	100	100
60	70	80
70	20	60

▣ FORCED AIR COOLING

ZWS10B · ZWS15B · ZWS30B

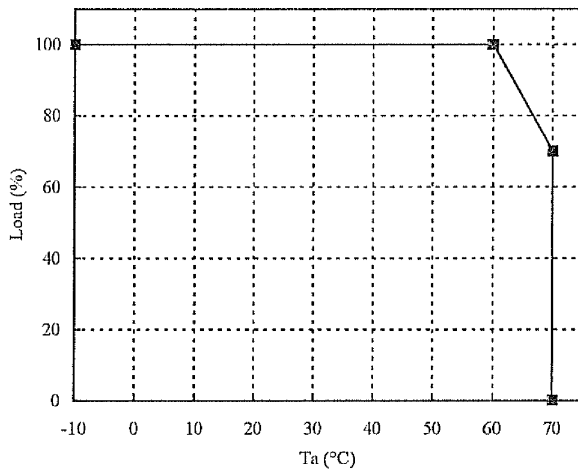

■ Mounting (A)-(F)

Ta (°C)	Load (%)
	Mounting (A)-(F)
-10~60	100
70	70

*Recommended minimum air velocity : 0.7m/s. (Measured at component side of PCB, air must flow through component side)
As a reference for forced air cooling, let air flow so that the C51 temperature is lower than "Electrolytic capacitor allowable max temperature" in the below table.

Electrolytic capacitor allowable Max temperature

MODEL	Maximum Temperature of C51	
	Ta : -10°C ~ +60°C	Ta : +60°C ~ +70°C
ZWS10B	65°C Max.	Ta + 5°C
ZWS15B	70°C Max.	Ta + 10°C
ZWS30B	70°C Max.	Ta + 10°C

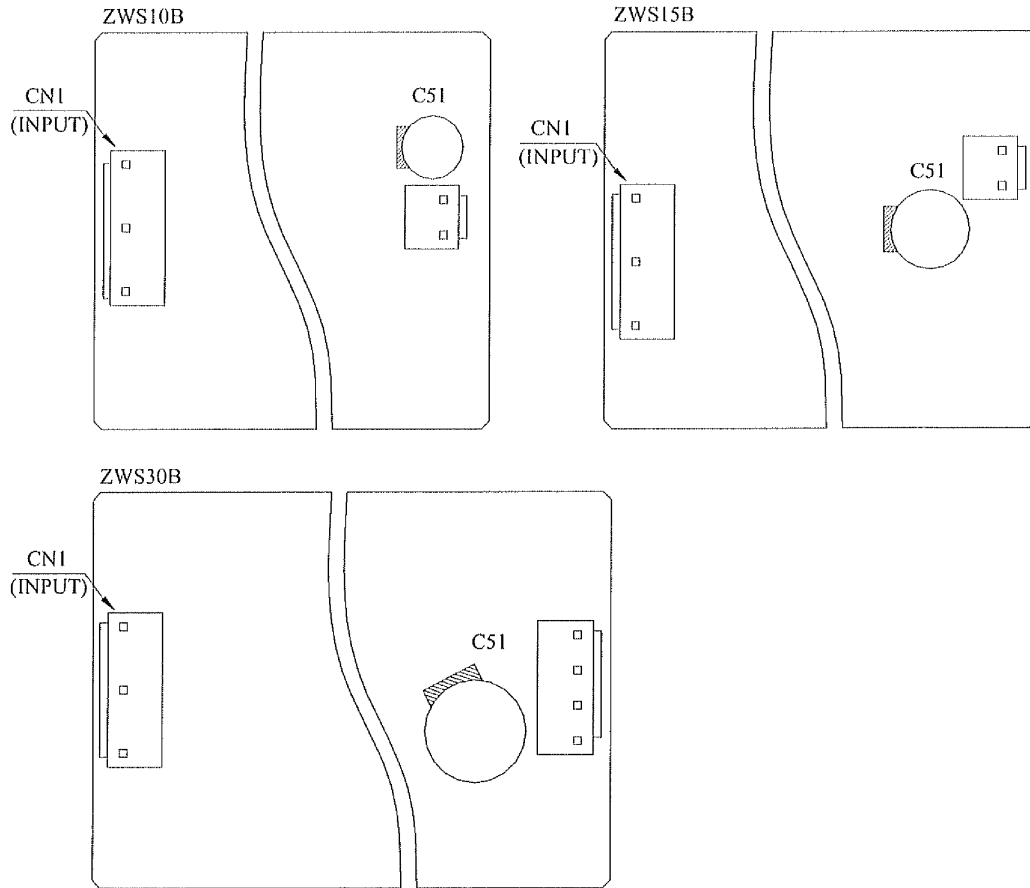

5-3. Output Derating vs Input Voltage

Output derating is required when the power supply operate below 90VAC input. Refer to table below for details

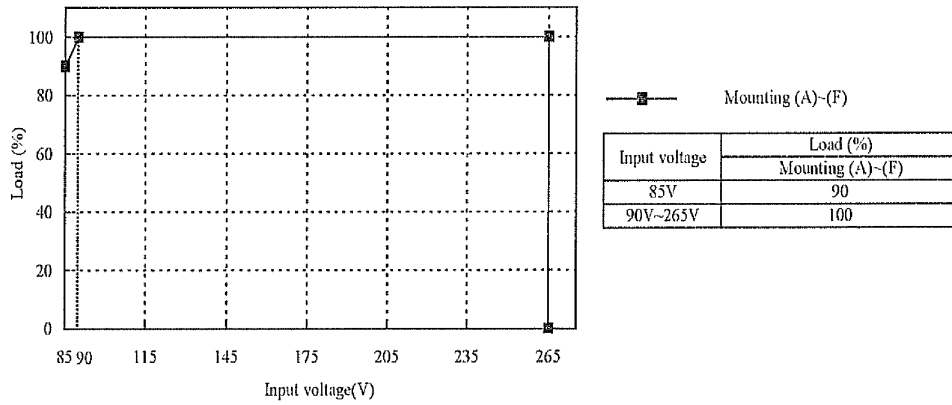

5-4. Mounting Method

Insert the spacer (Max ϕ 8) of height more than 8mm to lift the unit. And use all mounting holes for the unit installation. The vibration spec is specified under this mounting condition.

■ Mounting Holes size

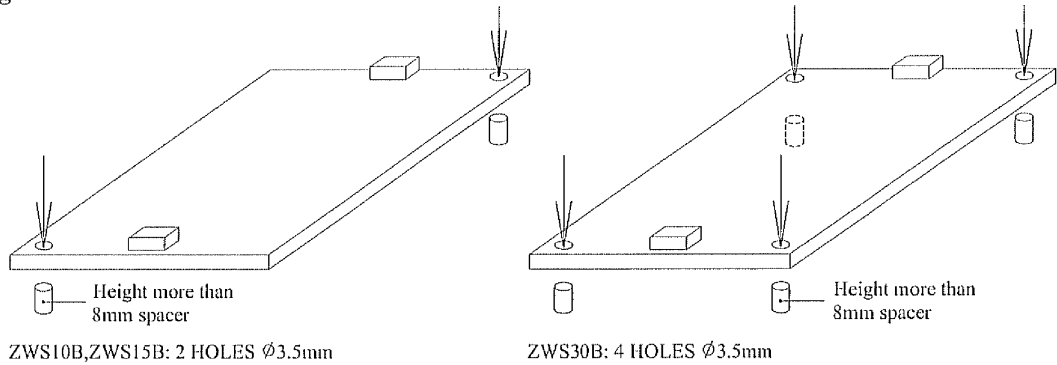

Allowable area by metal pieces is 8mm from each PCB corners. Refer to figure below.

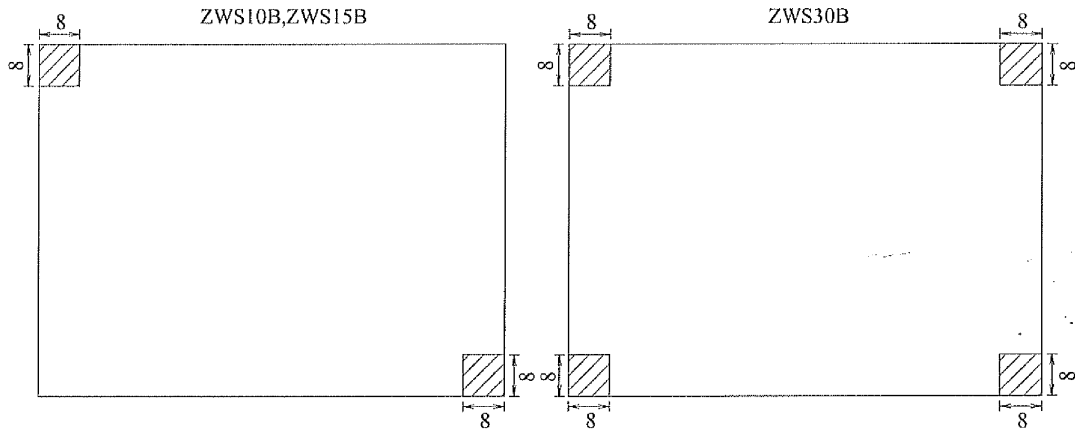

■ Condition to meet Isolation & Withstand Voltage standard.

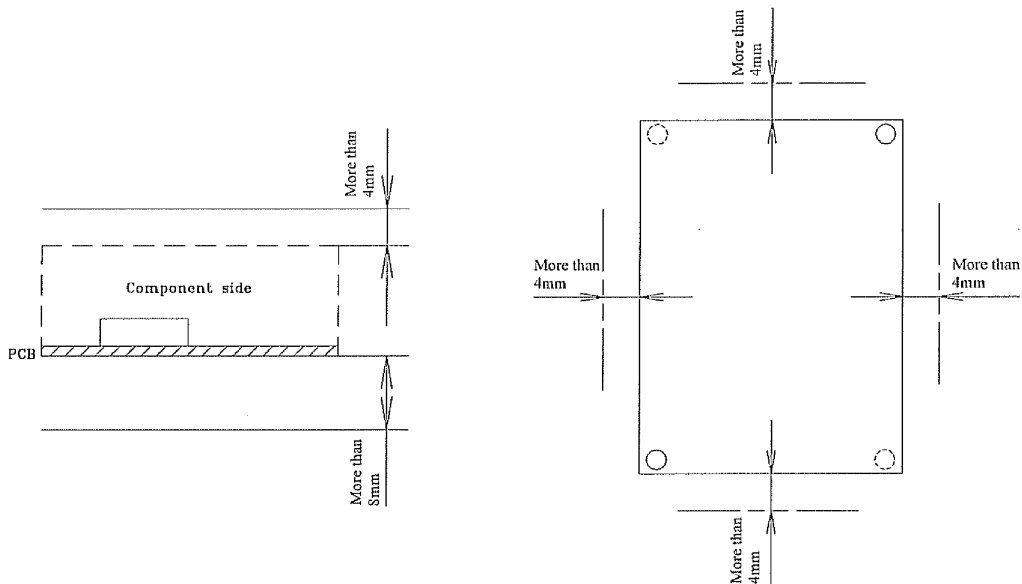

Keep 4mm space from the surfaces and sides of PCB. Especially, 8mm space is necessary from the solder surface.

If the space is not enough, the specification of isolation and withstand will not be satisfied.

Keep enough space in the power supply surroundings and the upper area of components for convection cooling.

⏏ (Protective Earth) should be connected to the earth terminal of the equipment. Also the mounting hole are should be connected to the Chassis by metal spacer. If not, the conducted noise, radiation noise and output noise will increase. Refer to figure below.

ZWS10B,ZWS15B

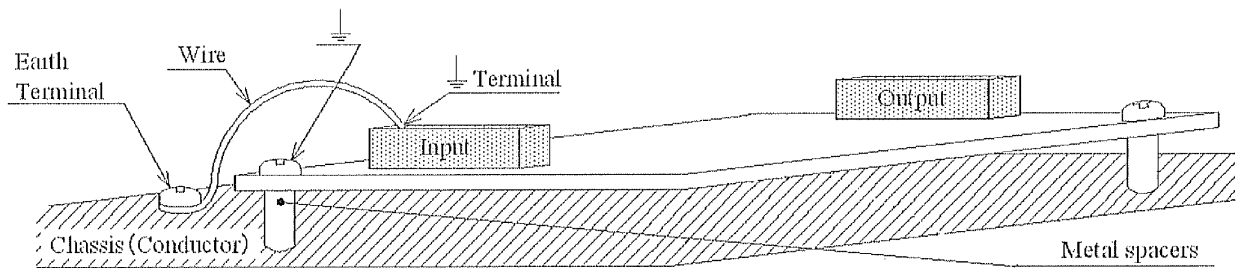

ZWS30B

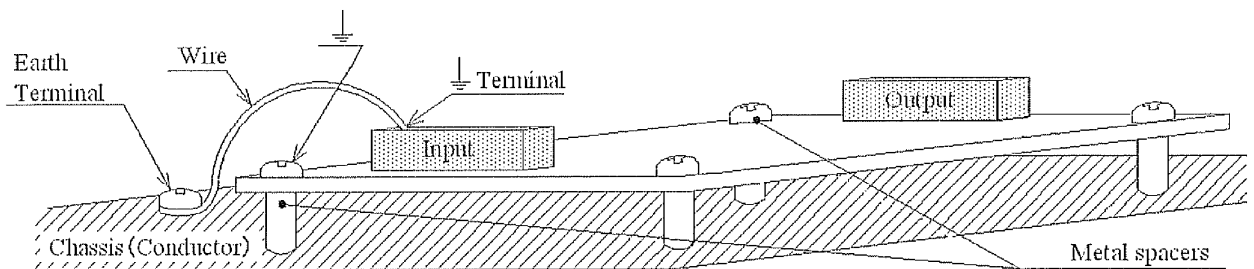

6. Wiring Method

- (1) The output load line and input line shall be separated each other and twisted individually to improve noise.
- (2) Use all lines as thick and short as possible to made lower impedance.
- (3) Noise can be reduced by attaching a capacitor to the load terminals.
- (4) For safety and EMI considerations, connect between \perp (Protective Earth) terminal of input connector and Frame Ground terminal of equipment firmly.

7. External Fuse Rating

Refer to the following fuse rating when selecting the external fuses that are to be used on input line. Surge current flows when line turns on. Have to use slow-blow or time-lag type fuse, not fast-blow fuse. Fuse rating is considered by in-rush current value at line turn-on. Do not select the fuse according to input current (RMS.) values under the actual load condition

ZWS10B, ZWS15B: 2.0A

ZWS30B: 3.15A

8. Before concluding that the unit is at fault

- (1) Check if the rated input voltage is connected.
- (2) Check if the wiring of input and output is correct.
- (3) Check if the wire thickness is enough.
- (4) Check if the output current and output wattage dose not over specification.
- (5) Check if the output voltage control (V.ADJ) is properly adjusted. OVP might be triggered and output is shut down.
- (6) Audible noise can be heard when input voltage waveform is not sinusoidal wave.
- (7) Audible noise can be heard during Dynamic-Load operation.
- (8) Ensure that a large capacitor is not connected on the output side. Please use within maximum capacitance shown below.

MODEL	Maximum external capacitance				
	3.3V	5V	12V	15V	24V
ZWS10B	10,000uF	10,000uF	2,000uF	1,400uF	300uF
ZWS15B	10,000uF	10,000uF	2,500uF	1,000uF	500uF
ZWS30B	10,000uF	10,000uF	2,700uF	1,500uF	600uF

9. Altitude

The clearance in power supply can meet 3000m altitude of IEC60664-1.

10. Warranty Period

As for the breakdown under a normal use during warranty period, repair is at free of charge.
For mounting method aside from the following, inquire our company.

ZWS10B · ZWS30B

■ CONVECTION COOLING

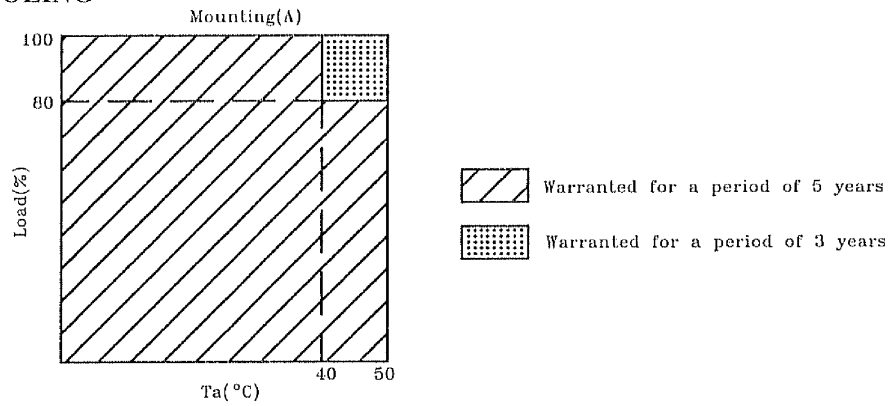

ZWS15B

■ CONVECTION COOLING

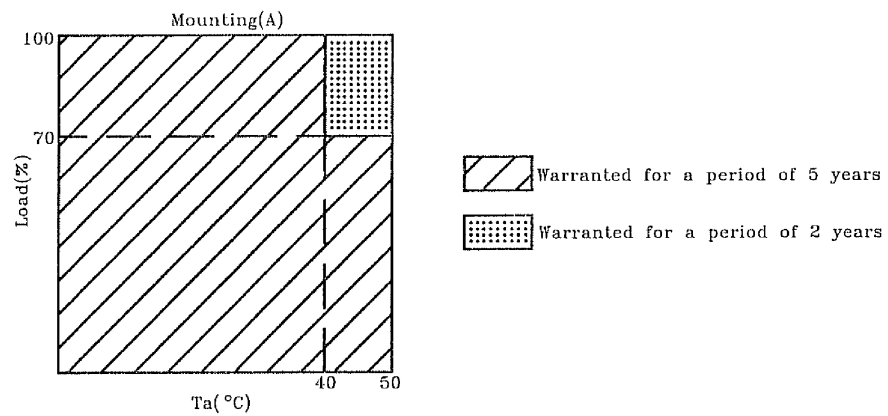

ZWS10B · ZWS15B · ZWS30B

■ FORCED AIR COOLING

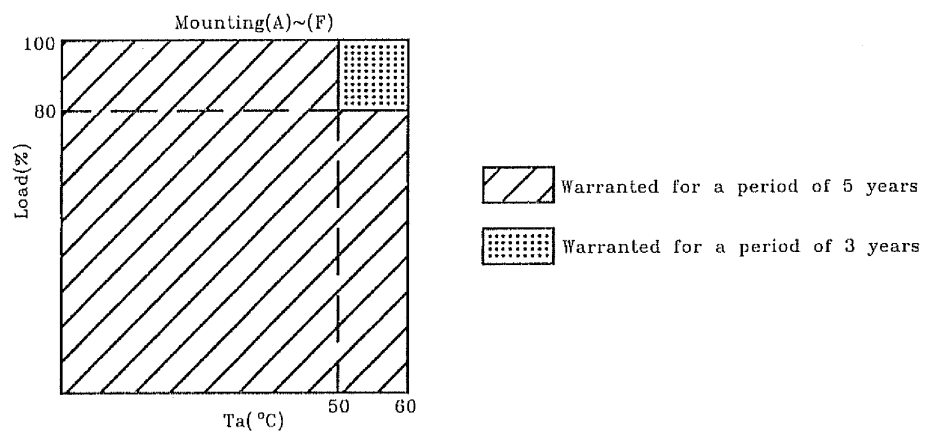

Following cases are not covered by warranty.

- (1) Improper usage like dropping products, applying shock and defects from operation exceeding specification of the units.
- (2) Defects resulting from natural disaster (fire, flood etc).
- (3) Unauthorized modifications or repair by the buyers' defects not cause by our company.