

## Ultralow power energy harvester and battery charger

Datasheet - production data

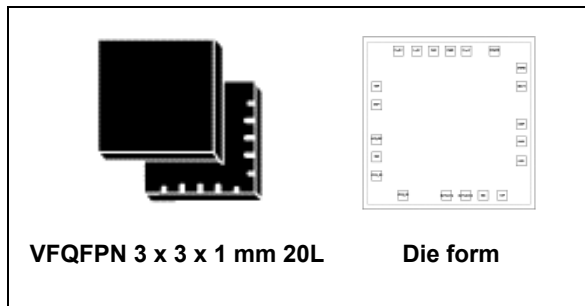

### Description

The SPV1050 is an ultralow power and high-efficiency energy harvester and battery charger, which implements the MPPT function and integrates the switching elements of a buck-boost converter.

The SPV1050 device allows the charge of any battery, including the thin film batteries, by tightly monitoring the end-of-charge and the minimum battery voltage in order to avoid the overdischarge and to preserve the battery life.

The power manager is suitable for both PV cells and TEG harvesting sources, as it covers the input voltage range from 75 mV up to 18 V and guarantees high efficiency in both buck-boost and boost configuration.

Furthermore the SPV1050 device shows very high flexibility thanks also to the trimming capability of the end-of-charge and undervoltage protection voltages. In such way any source and battery is matched.

The MPPT is programmable by a resistor input divider and allows maximizing the source power under any temperature and irradiance condition.

An unregulated voltage output is available (e.g. to supply a microcontroller), while two fully independent LDOs are embedded for powering sensors and RF transceivers. Both LDOs (1.8 V and 3.3 V) can be independently enabled through two dedicated pins.

### Features

- Transformerless thermoelectric generators and PV modules energy harvester
- High efficiency for any harvesting source
- Up to 70 mA maximum battery charging current
- Fully integrated buck-boost DC-DC converter
- Programmable MPPT by external resistors
- 2.6 V to 5.3 V trimmable battery charge voltage level ( $\pm 1\%$  accuracy)
- 2.2 V to 3.6 V trimmable battery discharge voltage level ( $\pm 1\%$  accuracy)
- Two fully independent LDOs (1.8 V and 3.3 V output)
- Enable/disable LDO control pins
- Battery disconnect function for battery protection
- Battery connected and ongoing charge logic open drain indication pins

### Applications

- Charge any battery type, including lithium based, solid state thin film and super-capacitor.
- WSN, HVAC, building and home automation, industrial control, remote metering, lighting, security, surveillance.
- Wearable and biomedical sensors, fitness.

# Contents

<b>1</b>	<b>Block diagram</b> .....	<b>5</b>
<b>2</b>	<b>Pin configuration</b> .....	<b>6</b>
<b>3</b>	<b>Pin description</b> .....	<b>7</b>
<b>4</b>	<b>Maximum ratings</b> .....	<b>9</b>
<b>5</b>	<b>Electrical characteristics</b> .....	<b>10</b>
<b>6</b>	<b>Functional description</b> .....	<b>13</b>
6.1	Battery charger .....	13
6.2	Boost configuration .....	16
6.3	Buck-boost configuration .....	20
6.4	MPPT setting .....	24
6.5	Power manager .....	26
<b>7</b>	<b>Package information</b> .....	<b>28</b>
7.1	VFQFPN20 3 x 3 x 1 mm - 20-lead pitch 0.4 package information .....	28
<b>8</b>	<b>Ordering information</b> .....	<b>32</b>
<b>Appendix A Application tips</b> .....		<b>33</b>
<b>9</b>	<b>Revision history</b> .....	<b>35</b>

## List of tables

Table 1.	Pin description . . . . .	7
Table 2.	Thermal data . . . . .	9
Table 3.	Absolute maximum ratings . . . . .	9
Table 4.	Electrical characteristics . . . . .	10
Table 5.	VFQFPN20 3 x 3 x 1 mm - 20-lead pitch 0.4 package mechanical data . . . . .	29
Table 6.	Die pad coordinates and pad size . . . . .	31
Table 7.	Device summary . . . . .	32
Table 8.	Document revision history . . . . .	35

## List of figures

Figure 1.	Block diagram . . . . .	5
Figure 2.	Pin configuration (top through view) . . . . .	6
Figure 3.	Battery management section . . . . .	14
Figure 4.	Boost configuration . . . . .	16
Figure 5.	Boost startup . . . . .	17
Figure 6.	MPPT tracking . . . . .	18
Figure 7.	Triggering of $V_{EOC}$ (BATT pin floating) . . . . .	18
Figure 8.	Efficiency vs. input current - $V_{OC} = 1.0\text{ V}$ . . . . .	19
Figure 9.	Efficiency vs. input current - $V_{OC} = 1.5\text{ V}$ . . . . .	19
Figure 10.	Efficiency vs. input current - $V_{OC} = 2.0\text{ V}$ . . . . .	19
Figure 11.	Efficiency vs. input current - $V_{OC} = 2.5\text{ V}$ . . . . .	19
Figure 12.	Buck-boost configuration . . . . .	20
Figure 13.	Buck-boost startup ( $I_{IN} = 5\text{ }\mu\text{A}$ ) . . . . .	21
Figure 14.	MPPT tracking . . . . .	22
Figure 15.	Efficiency vs. input current - $V_{OC} = 6\text{ V}$ . . . . .	23
Figure 16.	Efficiency vs. input current - $V_{OC} = 9\text{ V}$ . . . . .	23
Figure 17.	Efficiency vs. input current - $V_{OC} = 12\text{ V}$ . . . . .	23
Figure 18.	Efficiency vs. input current - $V_{OC} = 15\text{ V}$ . . . . .	23
Figure 19.	MPPT setup circuitry . . . . .	24
Figure 20.	Energy harvester equivalent circuit . . . . .	26
Figure 21.	Voltage vs. time at different C values and fixed current . . . . .	26
Figure 22.	LDO1 turn on with 100 mA load . . . . .	27
Figure 23.	LDO2 turn on with 100 mA load . . . . .	27
Figure 24.	VFQFPN20 3 x 3 x 1 mm - 20-lead pitch 0.4 package outline . . . . .	28
Figure 25.	Die form pad position (top view) . . . . .	30
Figure 26.	Tape and reel design . . . . .	32
Figure 27.	Inductor current and input voltage waveforms . . . . .	33

# 1 Block diagram

Figure 1. Block diagram

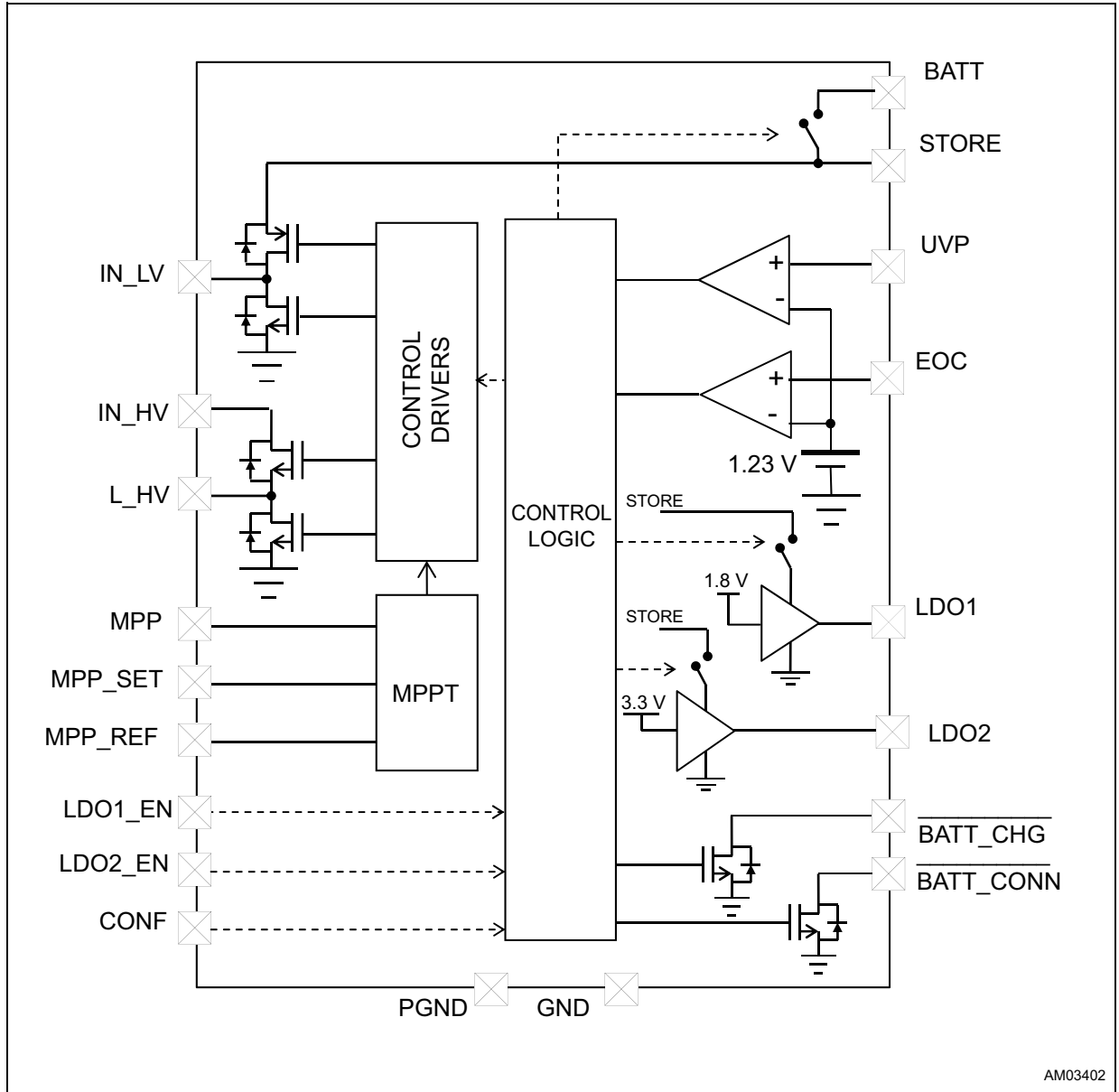

## 2 Pin configuration

Figure 2. Pin configuration (top through view)

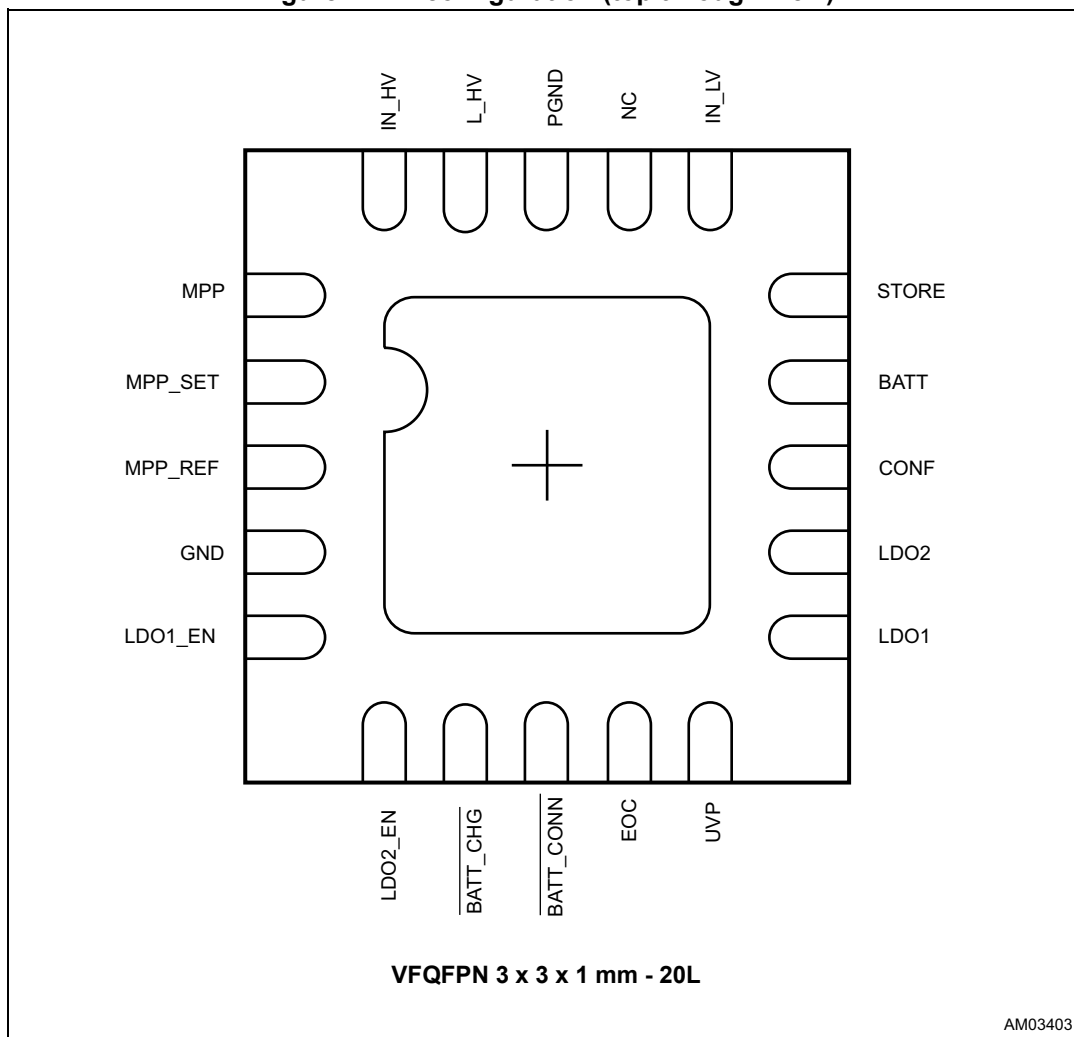

### 3 Pin description

**Table 1. Pin description**

Pin no.	Name	Type	Description
1	MPP	I	Max. power point tracking voltage sense pin. To be connected to the voltage source through a ladder resistor.
2	MPP-SET	I	Max. power point setting voltage pin. To be connected to the MPP pin through a ladder resistor. Connect to STORE if MPP function is not required.
3	MPP-REF	I	Max. power point reference voltage pin. To be connected to a 10 nF capacitor. Connect to an external voltage reference if MPP function is not required.
4	GND	GND	Signal ground pin.
5	LDO1_EN	I	If high, enables LDO1.
6	LDO2_EN	I	If high, enables LDO2.
7	$\overline{\text{BATT\_CHG}}$	O	Ongoing battery charge output flag pin (open drain). If low, it indicates that the battery is on charge. If high, it indicates that the battery is not on charge.
8	$\overline{\text{BATT\_CONN}}$	O	Battery status output flag pin (open drain). If high, it indicates that the pass transistor between the STORE and BATT pins is open (battery disconnected). If low, it indicates that the pass transistor between the STORE and BATT pins is closed (battery connected).
9	EOC	I	Battery end-of-charge pin. To be connected to the STORE pin through a resistor divider between EOC and GND.
10	UVP	I	Battery undervoltage protection pin. To be connected to the STORE pin through a resistor.
11	LDO1	O	1.8 V regulated output voltage pin.
12	LDO2	O	3.3 V regulated output voltage pin.
13	CONF	I	Configuration pin. Boost configuration: to be connected to the voltage supply source. Buck-boost configuration: to be connected to ground.
14	BATT	I/O	Battery connection pin.
15	STORE	I/O	Tank capacitor connection pin.
16	IN_LV	I	Low voltage input source. It has to be connected to the inductor for both boost and buck-boost configuration.
17	NC	-	Not connected.
18	PGND	PGND	Power ground pin.

Table 1. Pin description (continued)

Pin no.	Name	Type	Description
19	L_HV	I	Input pin for buck-boost configuration. Boost configuration: to be connected to ground. Buck-boost configuration: to be connected to the inductor.
20	IN_HV	I	High voltage input source. Boost configuration: to be connected to ground. Buck-boost configuration: to be connected to the voltage supply source.



## 4 Maximum ratings

**Table 2. Thermal data**

Symbol	Parameter	Value		Unit
		Min.	Max.	
$R_{thj-c}$	Max. thermal resistance, junction to case	-	7.5	°C/W
$R_{thj-a}^{(1)}$	Max. thermal resistance, junction to ambient	-	49	°C/W
$P_{TOT}$	Maximum power dissipation at $T_{amb} = 85\text{ °C}$	-	1	W
$T_j$	Junction temperature range	-40 ÷ 125		°C
$T_{storage}$	Storage temperature	150		°C

1. Measured on 2-layer application board FR4, Cu thickness = 17 um with total exposed pad area = 16 mm<sup>2</sup>

**Table 3. Absolute maximum ratings**

Symbol	Parameter	Value	Unit
IN_LV	Analog input	$V_{STORE} + 0.3$	V
IN_HV	Analog input	20	V
L_HV	Analog input	$IN\_HV + 0.3$	V
CONF	Analog input	5.5	V
MPP	Analog input	5.5	V
MPP-SET	Analog input	5.5	V
MPP-REF	Analog input	5.5	V
BATT	Analog input/output	5.5	V
STORE	Analog input/output	5.5	V
UVP	Analog input	$V_{STORE} + 0.3$	V
EOC	Analog input	$V_{STORE} + 0.3$	V
$\overline{BATT\_CONN}$	Digital output	5.5	V
$\overline{BATT\_CHG}$	Digital output	5.5	V
LDO1_EN	Digital input	$V_{STORE} + 0.3$	V
LDO2_EN	Digital input	$V_{STORE} + 0.3$	V
LDO1	Analog output	$V_{STORE} + 0.3$	V
LDO2	Analog output	$V_{STORE} + 0.3$	V
PGND	Power ground	0	V
GND	Signal ground	-0.3 to 0.3	V

## 5 Electrical characteristics

$V_{STORE} = 4\text{ V}$ ,  $T_{amb} = -40\text{ to }85\text{ }^{\circ}\text{C}$ , unless otherwise specified. Voltage with respect to GND unless otherwise specified.

**Table 4. Electrical characteristics**

Symbol	Parameter	Test condition	Min.	Typ.	Max.	Unit	
<b>Battery operating range</b>							
$I_{BATT}$	Maximum battery charging current	-	-	-	70	mA	
$V_{BATT}$	BATT pin voltage range	-	2.2	-	5.3	V	
$V_{BATTACC}$	Battery voltage accuracy	-	-1	-	+1	%	
$R_{BATT}$	Pass transistor resistance	-	6	7	8	$\Omega$	
<b>Bandgap</b>							
$V_{BG}$	Internal reference voltage	-	-	1.23	-	V	
	Accuracy	-	-1	-	+1	%	
<b>UVP</b>							
$V_{UVP}$	Undervoltage protection range	$(V_{UVP} + UVP_{HYS}) < (V_{EOC} - EOC_{HYS})$	2.2	-	3.6	V	
<b>EOC</b>							
$V_{EOC}$	Battery end-of-charge voltage	$(V_{UVP} + UVP_{HYS}) < (V_{EOC} - EOC_{HYS})$	2.6	-	5.3	V	
$EOC_{HYS}$	EOC hysteresis	$V_{STORE}$ decreasing	-	-1	-	%	
<b>STORE</b>							
$V_{STORE}$	STORE pin voltage operating range	-	$V_{UVP}$	-	$V_{EOC}$	V	
<b>Static current consumption</b>							
$I_{SD}$	Shutdown current	Shut down mode: Before first startup or $\overline{BATT\_CONN}$ high $T_{AMB} < 60\text{ }^{\circ}\text{C}$	-	-	1	nA	
$I_{SB}$	Standby current	Standby mode: BATT_CONN low, BATT_CHG high, $V_{STORE} = 5.3\text{ V}$ and LDO1,2_EN low $T_{AMB} = 25\text{ }^{\circ}\text{C}$	-	0.8	-	$\mu\text{A}$	
$I_{OP}$	Operating current in open load	Operating mode (LDOs in open load) BATT_CONN low BATT_CHG high $T_{AMB} = 25\text{ }^{\circ}\text{C}$	LDO1_EN = 1 or LDO2_EN = 1	-	1.7	-	$\mu\text{A}$
			LDO1,2_EN = 1	-	2.6	-	

Table 4. Electrical characteristics (continued)

Symbol	Parameter	Test condition	Min.	Typ.	Max.	Unit
<b>DC-DC converter</b>						
$V_{IN\_LV}$	Input voltage range	Boost configuration	0.15	-	$V_{EOC}$	V
$V_{IN\_HV}$		Buck-boost configuration	0.15	-	18	
$V_{IN\_MIN}$	Minimum input voltage at startup	Boost configuration $\overline{BATT\_CONN}$ high or at first startup	-	0.55	0.58	V
		Buck-boost configuration $\overline{BATT\_CONN}$ high or at first startup	-	2.6	2.8	
$I_{B\_SU}$	Startup input current	Boost configuration	-	30	-	$\mu A$
$I_{BB\_SU}$		Buck-boost configuration	-	5	-	$\mu A$
$R_{ON\_B}$	Low-side MOS resistance	Boost configuration	0.5	1.0	1.5	$\Omega$
$SR_{ON\_B}$	Synchronous rectifier MOS resistance		0.5	1.0	1.5	
$R_{ON\_BB}$	Low-side MOS resistance	Buck-boost configuration	1	1.5	2	$\Omega$
$SR_{ON\_BB}$	Synchronous rectifier MOS resistance		1	1.5	2	
$f_{SW}$	Maximum allowed switching frequency	Boost and buck-boost configurations	-	-	1	MHz
$UVLO_H$	Undervoltage lockout threshold ( $V_{STORE}$ increasing)	Boost and buck-boost configurations	-	2.6	2.8	V
$UVLO_L$	Undervoltage lockout threshold ( $V_{STORE}$ decreasing)		2	2.1	-	V
<b>MPPT</b>						
$T_{TRACKING}$	MPPT tracking period	$\overline{BATT\_CHG}$ low	12	-	20	s
$T_{SAMPLE}$	MPPT sampling time	$\overline{BATT\_CHG}$ high	0.3	-	0.5	s
$V_{MPP}$	MPP pin voltage range	Boost and buck-boost configurations	0.075	-	$V_{UVP}$	V
$MPP_{ACC}$	MPP tracking accuracy	Boost and buck-boost configurations	95	-		%
<b>LDO</b>						
$V_{LDO1,2}$	LDO1,2 adjusted output voltage	LDO1_EN = 1	-	1.8	-	V
		LDO2_EN = 1	-	3.3	-	
$\Delta V_{LDO1,2}$	LDO1 dropout	$V_{UVP} + 200 \text{ mV} < V_{BATT} \leq 5.3 \text{ V}$ $I_{LDO1} = 100 \text{ mA}$	-	-	0.5	%
	LDO2 dropout	$3.3 < V_{UVP} + 200 \text{ mV} < V_{BATT} \leq 5.3 \text{ V}$ $I_{LDO2} = 100 \text{ mA}$	-	-	0.5	
$t_{LDO}$	LDO1,2 startup time	$\overline{BATT\_DIS}$ low $C_{LDO1,2} = 100 \text{ nF}$	-	-	1	ms
$I_{LDO1}^{(1)}$	$I_{OUT}$ max from LDO1	-	-	-	200	mA

Table 4. Electrical characteristics (continued)

Symbol	Parameter	Test condition	Min.	Typ.	Max.	Unit
$I_{LDO2}^{(1)}$	$I_{OUT}$ max from LDO2	-	-	-	200	mA
$V_{LDO1,2\_EN\_H}$	LDO1,2 enable input HIGH	-	1	-	-	V
$V_{LDO1,2\_EN\_L}$	LDO1,2 enable input LOW	-	-	-	0.5	V
<b>Digital output</b>						
$V_{\overline{BATT\_CONN\_L}}$	$V_{BATT\_DIS}$ LOW	1 mA sink current	40	70	150	mV
$V_{\overline{BATT\_CHG\_L}}$	$V_{XBATT\_CHG}$ LOW	1 mA sink current	40	70	150	mV

1. Guaranteed by design, not tested in production.

## 6 Functional description

The SPV1050 is an ultralow power energy harvester with an embedded MPPT algorithm, a battery charger and power manager designed for applications up to about 400 mW.

The SPV1050 device integrates a DC-DC converter stage that can be configured as boost or buck-boost by tying the CONF pin to PV+/TEG+ or to ground respectively as shown in [Figure 4](#) and [Figure 12 on page 20](#).

If the embedded MPPT algorithm is enabled, the device regulates the working point of the DC-DC converter in order to maximize the power extracted from the source by tracking its output voltage. See further details in [Section 6.2: Boost configuration on page 16](#) and [Section 6.3: Buck-boost configuration on page 20](#).

The MPPT algorithm can be disabled by shorting the MPP-SET pin to the STORE pin, and by providing an external voltage to the MPP-REF pin.

In case of low impedance source (e.g. USB), the MPP-REF must be connected to GND. The IC will switch at the highest duty cycle possible until the  $V_{EOC}$  on the STORE pin is triggered.

In case of high impedance source with limited current capability (i.e. if the source is unable to sustain switching at the maximum duty cycle), the MPP-REF pin must be connected to a voltage reference selected such that  $V_{MPP-REF} > V_{IN(MIN)}$ . This voltage reference can be set through a resistor ladder connected to STORE or any other voltage reference available in the application.

If the MPP pin is connected to the source by a resistor ladder, then the same consideration must be extended to the MPP pin. Referring to [Figure 19](#) (where connections between MPP-SET to R2-R3 must be open and MPP-SET must be considered as connected to STORE):

- If  $R1 = 0 \Omega$ : then  $V_{MPP-REF} = V_{IN(MIN)}$
- Otherwise:  $V_{MPP-REF} = V_{MPP(MIN)} = V_{IN(MIN)} * (R2+R3)/R1$

### 6.1 Battery charger

In order to guarantee the lifetime and safety of the battery, the SPV1050 device controls an integrated pass transistor between the STORE and BATT pins and implements both the undervoltage (UVP) and the end-of-charge (EOC) protection thresholds.

Figure 3. Battery management section

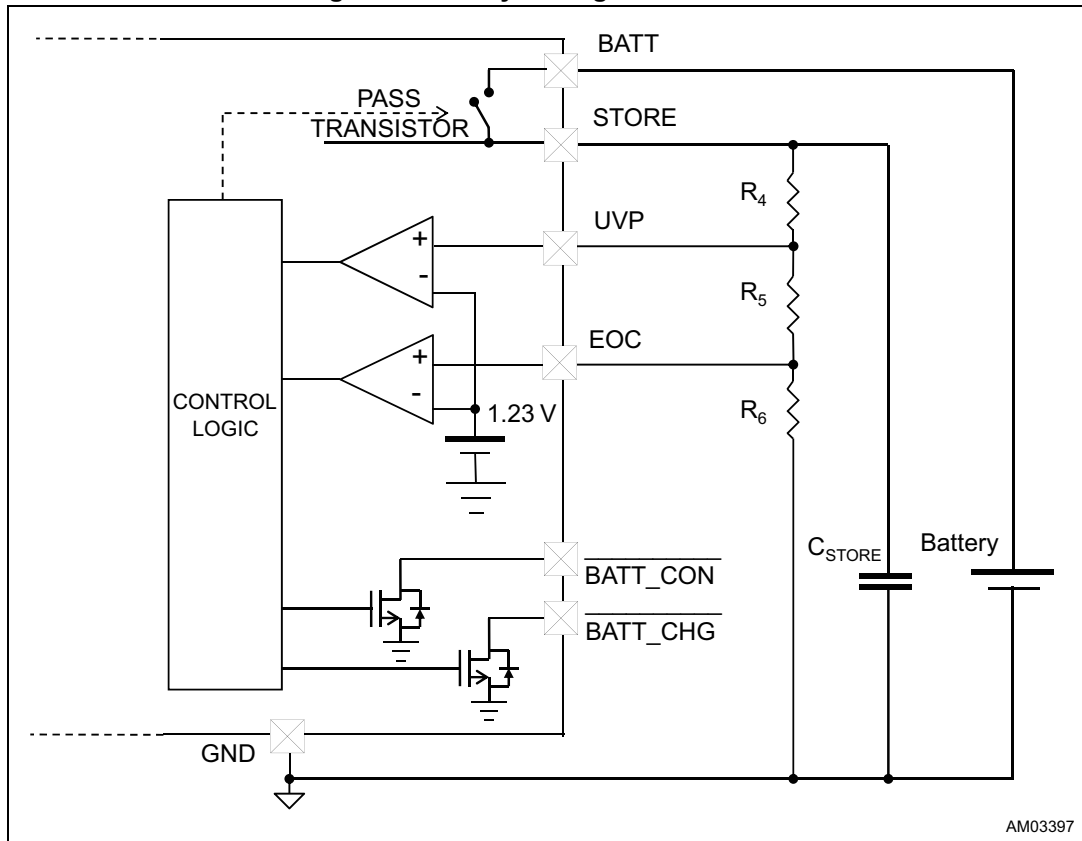

Before the first startup the pass transistor is open, so that the leakage from the battery is lower than 1 nA. The pass transistor will be closed once the voltage on the STORE pin will rise such that the EOC threshold  $V_{EOC}$  is triggered. If the battery is full, and until  $V_{STORE} > V_{EOC} - EOC_{HYS}$ , the DC-DC converter will stop switching to avoid battery overcharge.

On the contrary, in order to avoid the overdischarge of the battery, the pass transistor will be opened once the voltage on the STORE pin will decrease down to UVP threshold  $V_{UVP}$ .

These functions are simply implemented by the control of two voltage thresholds,  $V_{UVP}$  and  $V_{EOC}$ , which can be regulated by a resistor partitioning ( $R_4$ ,  $R_5$ ,  $R_6$ ) between STORE, UVP and EOC pins.

The scaled voltages on the UVP and EOC pins will be compared with the internal bandgap voltage reference  $V_{BG}$  set at 1.23 V.

The design rules to setup the  $R_4$ ,  $R_5$  and  $R_6$  are the following:

**Equation 1**

$$V_{BG} = V_{UVP} \cdot (R_5 + R_6) / (R_4 + R_5 + R_6)$$

**Equation 2**

$$V_{BG} = V_{EOC} \cdot R_6 / (R_4 + R_5 + R_6)$$

In order to minimize the leakage due to the output resistor partitioning it has to be typically:

**Equation 3**

$$10 \text{ M}\Omega \leq R4 + R5 + R6 \leq 20 \text{ M}\Omega$$

Further, the SPV1050 device provides two open drain digital outputs to an external microcontroller:

- **BATT\_CONN**  
This pin is pulled down when the pass transistor is closed. It will be released once the pass transistor will be opened (e.g. triggering of  $V_{UVP}$ ). If used, this pin must be pulled-up to the STORE by a 10 M $\Omega$  (typical) resistor.
- **BATT\_CHG**  
This pin is pulled down when the DC-DC converter is switching, while it's released when it is not switching, i.e. when the EOC threshold is triggered until the voltage on the STORE pin drops at  $V_{EOC} - EOC_{HYS}$ , when the UVLO threshold is triggered or during the  $T_{SAMPLE}$  of the MPPT algorithm. If used, this pin must be pulled-up to the STORE by a 10 M $\Omega$  (typical) resistor.





Figure 5 shows the behavior of input voltage  $V_{IN}$  and  $V_{STORE}$  at the startup.

Figure 5. Boost startup

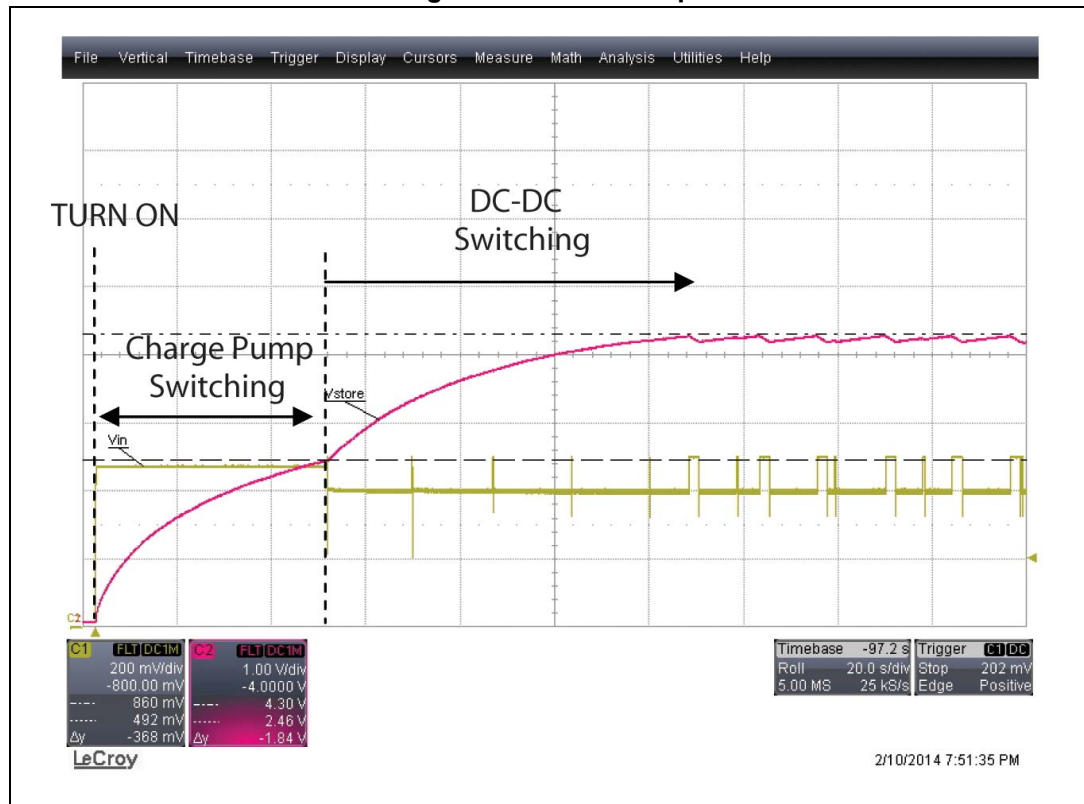

In the range  $2.6 \text{ V} \leq V_{STORE} < V_{EOC}$  the voltage is boosted by the DC-DC converter. In this voltage range the SPV1050 device sets its internal impedance according to the integrated MPPT algorithm (the MPPT mode is active). The SPV1050 device will stop switching for 400 ms ( $T_{SAMPLE}$ ) every 16 seconds ( $T_{TRACKING}$ ). During the  $T_{SAMPLE}$ , the input open circuit voltage  $V_{OC}$  is sampled by charging the capacitor on the MPP-REF pin. Once the  $T_{SAMPLE}$  is elapsed, the DC-DC converter will start switching back by setting its own impedance such that  $V_{IN}$  stays as close as possible to  $V_{MPP}$  of the source. A resistor partitioning connected between the source and the pins MPP and MPP-SET has to be properly selected, in order to match the manufacturer's specs. Please refer to [Section 6.4: MPPT setting on page 24](#) for further details.

The periodic sampling of  $V_{OC}$  guarantees the best MPPT in case of source condition variations (e.g. irradiation/thermal gradient and/or temperature changes).

Figure 6 shows the input voltage waveform of a PV panel supplying  $V_{OC} = 1.25\text{ V}$  and  $V_{MPP} = 1.05\text{ V}$ .

Figure 6. MPPT tracking

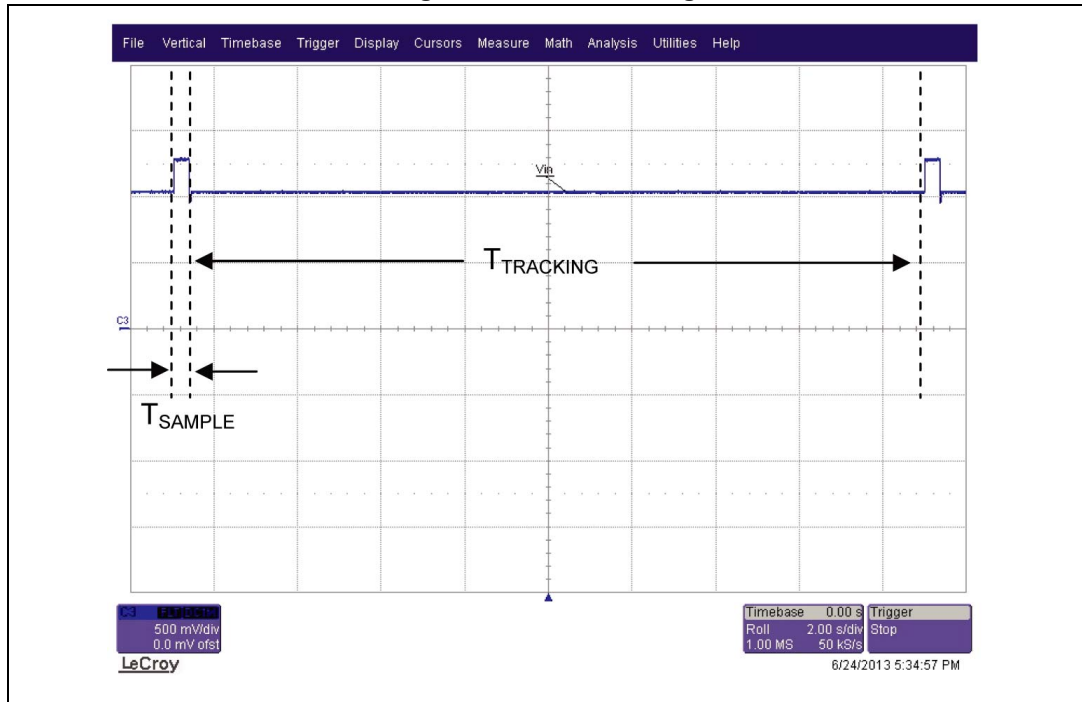

Once the  $V_{EOC}$  threshold is triggered, the switching of the DC-DC converter is stopped until  $V_{STORE}$  will decrease to  $V_{EOC} - EOC_{HYS}$ .

Figure 7. Triggering of  $V_{EOC}$  (BATT pin floating)

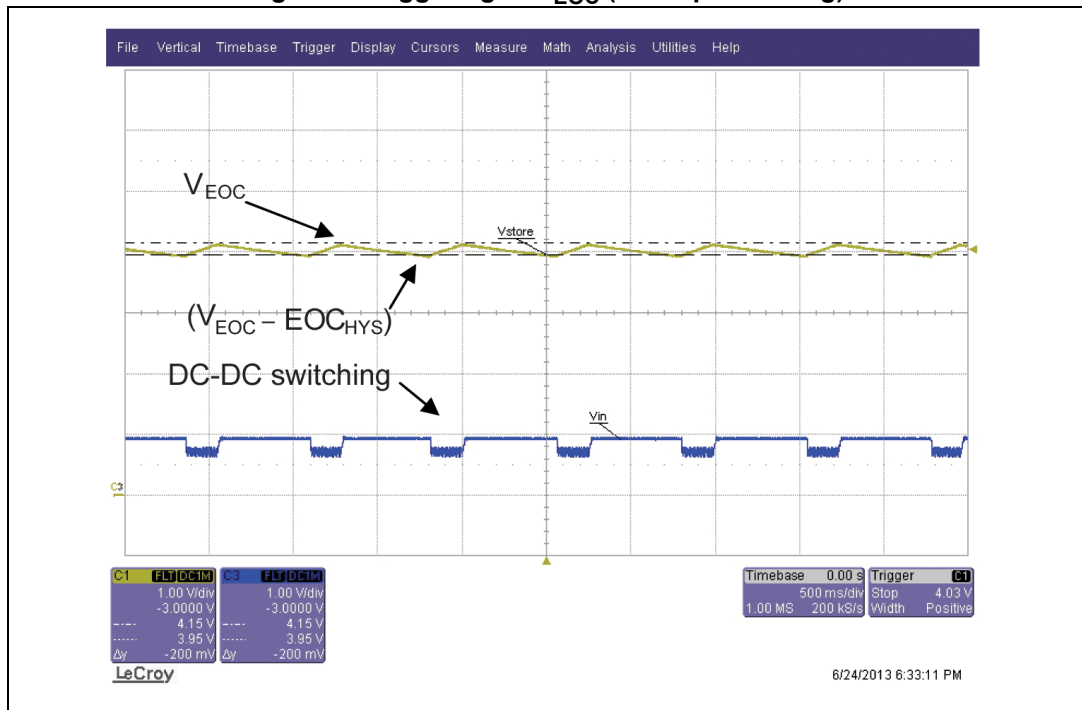

The following plots from *Figure 8* to *Figure 11* show the power efficiency of the DC-DC converter configured in boost mode at  $T_{amb} = 25\text{ }^{\circ}\text{C}$  in some typical use cases at different open circuit voltages:

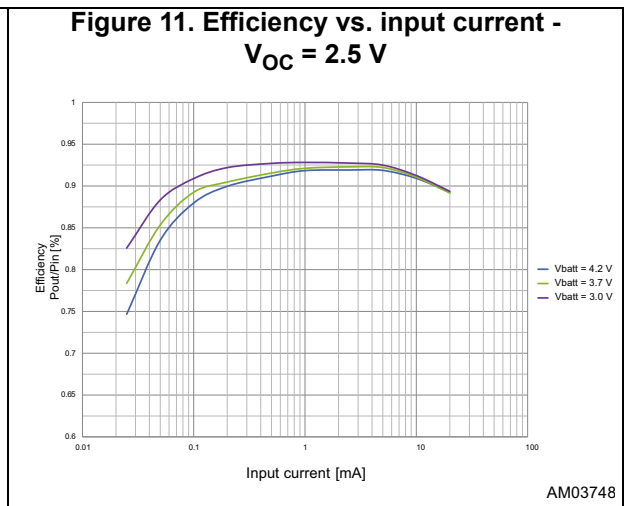
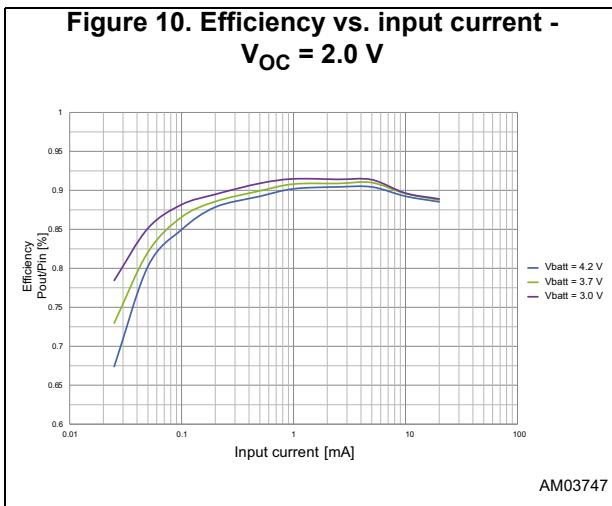
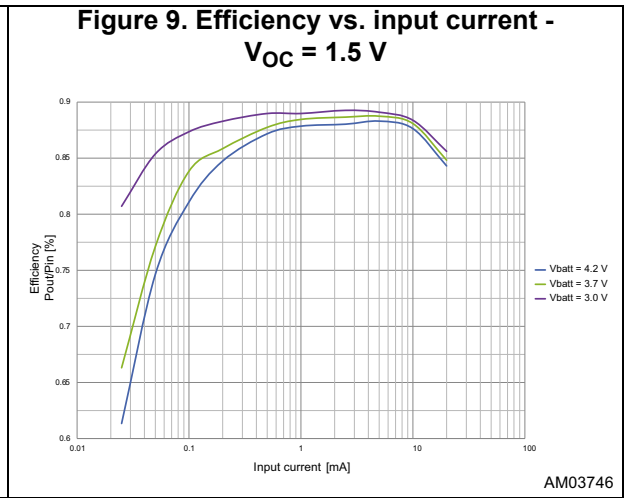
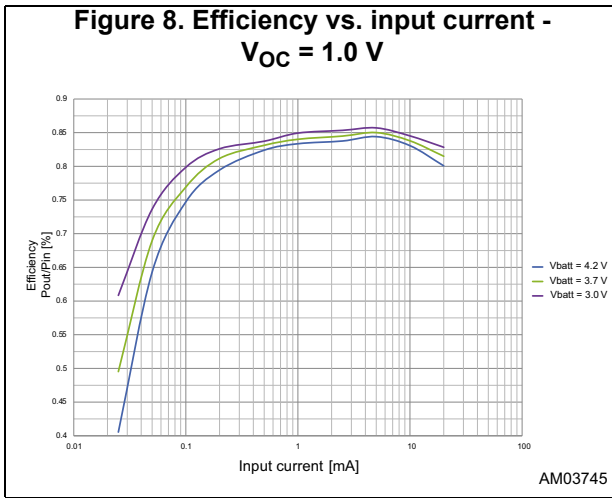

### 6.3 Buck-boost configuration

Figure 12 shows the buck-boost application circuit.

Figure 12. Buck-boost configuration

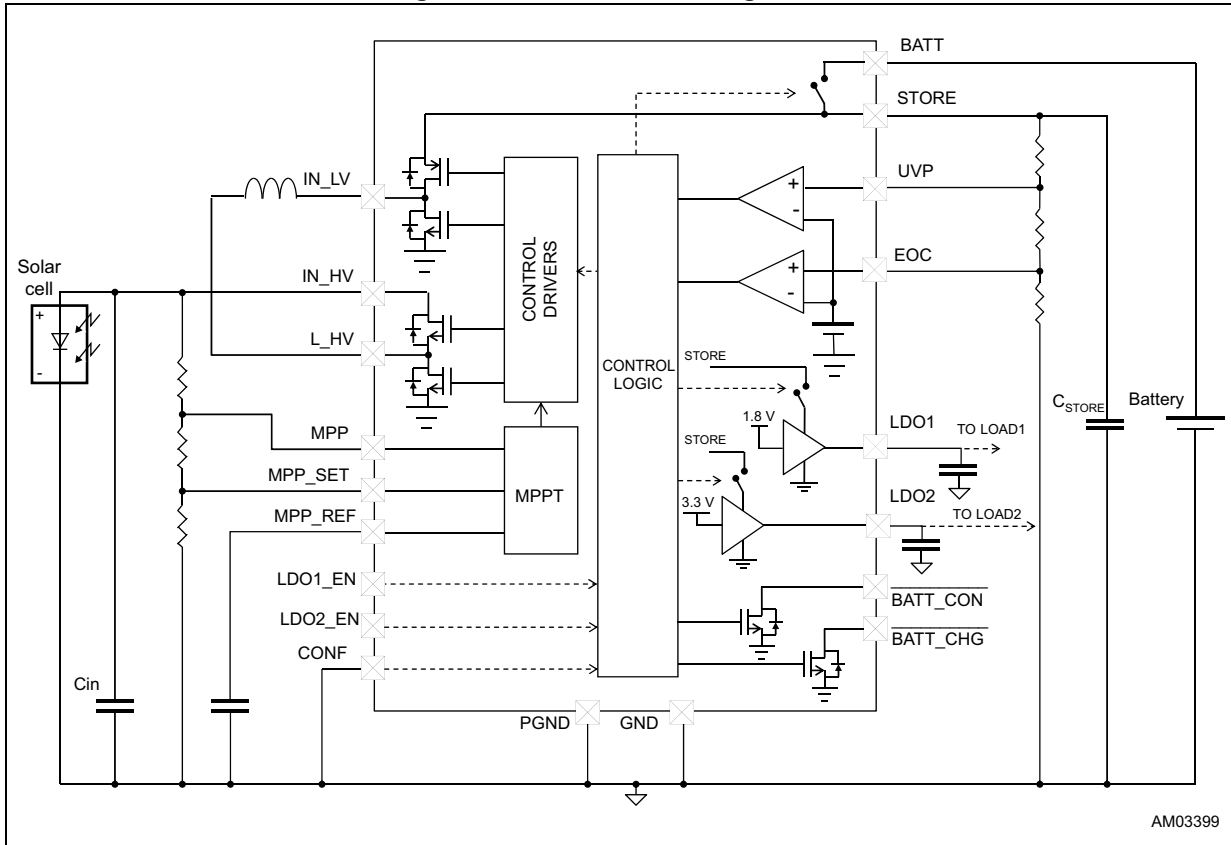

In case of buck-boost configuration, once the harvested source is connected, the IN\_HV and STORE pins will be internally shorted until  $V_{STORE} < 2.6\text{ V}$ . [Figure 13](#) shows the behavior of the input voltage  $V_{IN\_HV}$  and  $V_{STORE}$  at the startup.

**Figure 13. Buck-boost startup ( $I_{IN} = 5\ \mu\text{A}$ )**



In the range  $2.6\text{ V} \leq V_{STORE} < V_{EOC}$  the integrated DC-DC converter will start switching. In this operating range the SPV1050 input impedance is set by the embedded MPPT algorithm (the MPPT mode is active). The SPV1050 device will stop switching for 400ms ( $T_{SAMPLE}$ ) every 16 seconds ( $T_{TRACKING}$ ). During the  $T_{SAMPLE}$ , the input open circuit voltage  $V_{OC}$  is sampled by charging the capacitor on the MPP-REF pin. Once the  $T_{SAMPLE}$  is elapsed, the DC-DC converter will start switching back by setting its own impedance such that  $V_{IN}$  stays as close as possible to  $V_{MPP}$  of the source. A resistor partitioning connected between the source and the pins MPP and MPP-SET has to be properly selected in order to match the  $V_{MPP}$  given by the source manufacturer. Please refer to [Section 6.4: MPPT setting](#) for further details.

The periodic sampling of  $V_{OC}$  guarantees the best MPPT in case of source condition variations (e.g. irradiation and/or temperature changes).

Figure 14 shows the MPPT tracking form in case of  $V_{OC} = 9.9\text{ V}$  and  $V_{MPP} = 8.2\text{ V}$ .

Figure 14. MPPT tracking

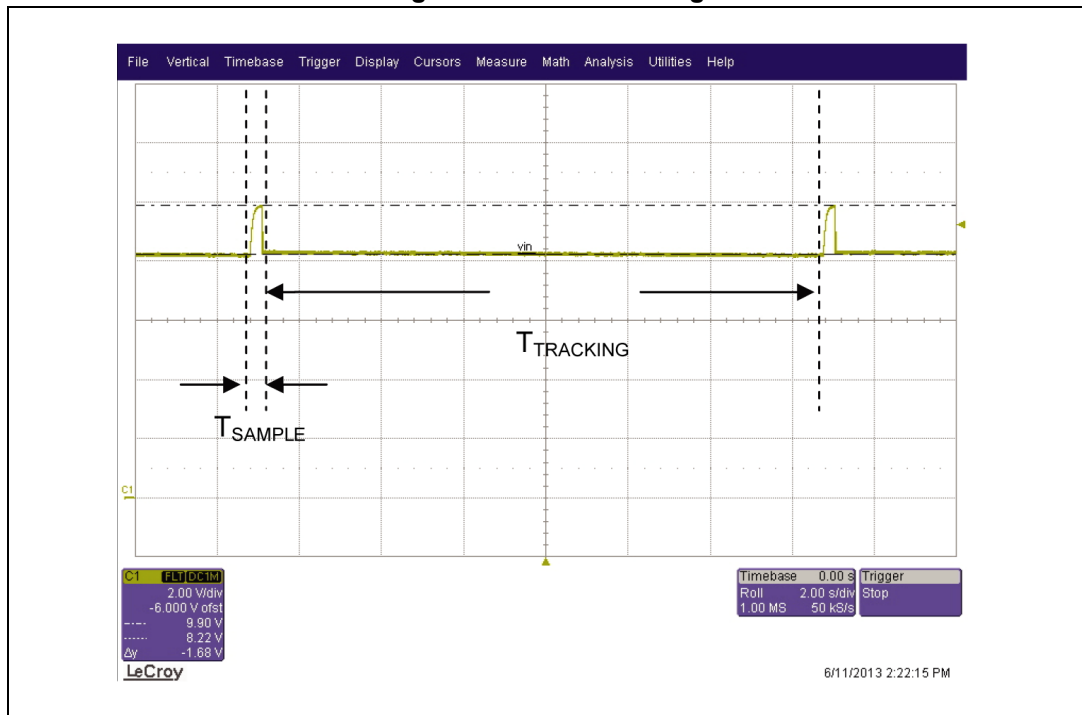

The following plots from *Figure 15* to *Figure 18* show the power efficiency of the DC-DC converter configured in buck-boost mode at  $T_{amb} = 25\text{ }^{\circ}\text{C}$  in some typical use cases:

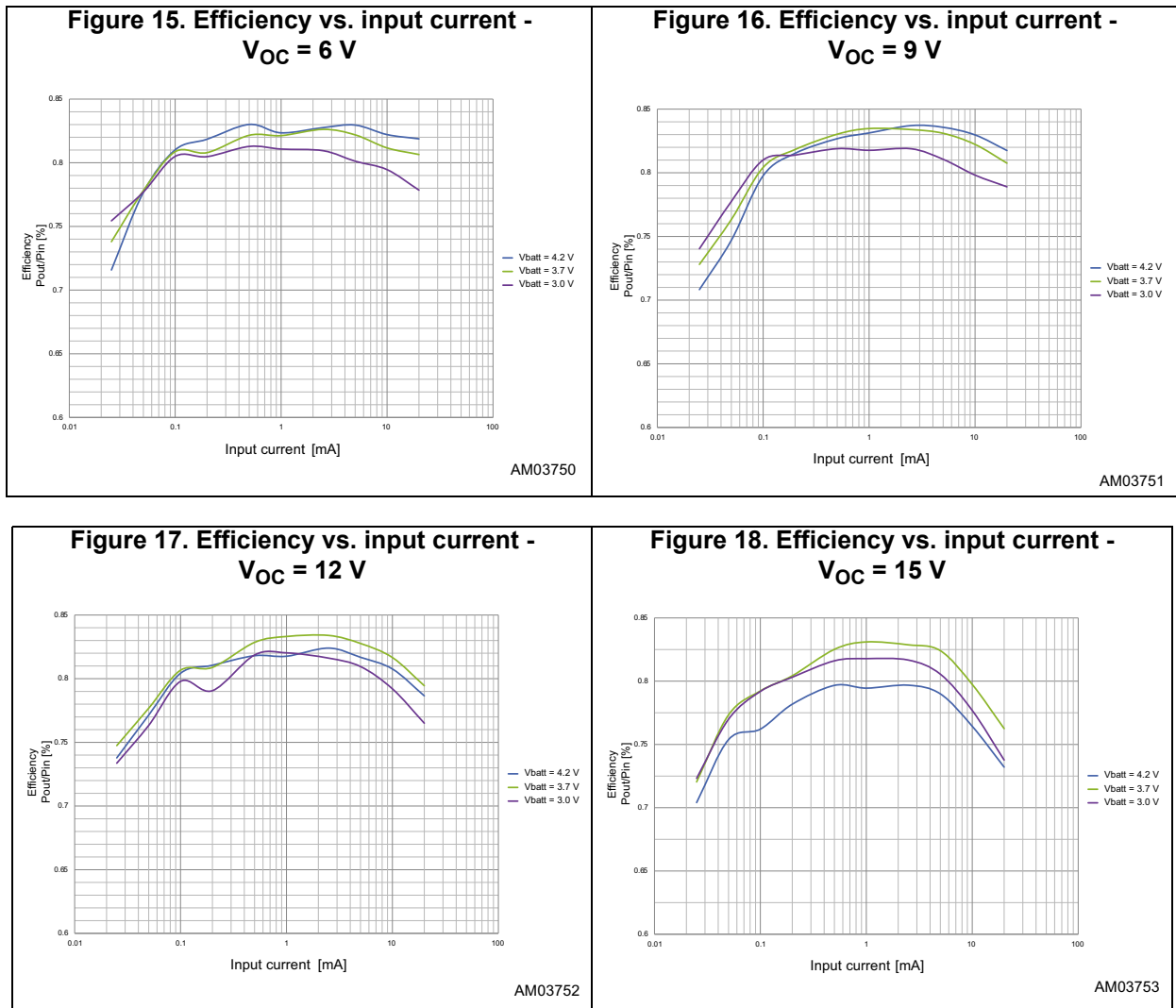

### 6.4 MPPT setting

When the MPPT feature is enabled, the SPV1050 device sets its working point such that  $V_{IN} = V_{MPP}$ . In fact,  $V_{MPP}$  is a fraction of the open circuit voltage  $V_{OC}$  of the harvesting source.

Figure 19. MPPT setup circuitry

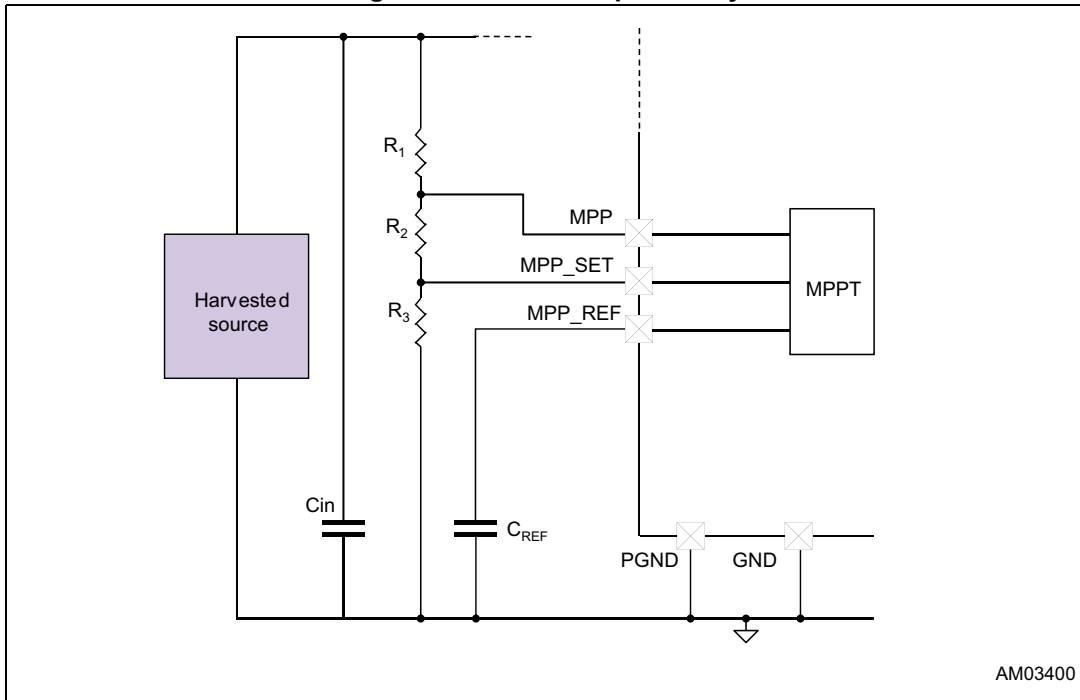

AM03400

The maximum power point is set through the input resistor partitioning R1, R2 and R3.

First of all, set the total input resistance ( $R1 + R2 + R3$ ) considering the maximum acceptable leakage current ( $I_{LEAKAGE}$ ):

**Equation 4**

$$I_{LEAKAGE} = V_{OC} / (R1 + R2 + R3)$$

Typically, assuming  $10\text{ M}\Omega \leq R1 + R2 + R3 \leq 20\text{ M}\Omega$ , the leakage on the input resistor partitioning can be considered as negligible.

Then set the R2 + R3 selecting the minimum between the results of equations 5 and 6 which consider that the voltage on the MPP pin must be lower than the minimum  $V_{UVP}$  ( $V_{UVP(min)} = 2.2\text{ V}$ ) and the energy balance on the inductor even at very low input power (see details in Appendix A, Application tips), respectively:

**Equation 5**

$$R2 + R3 \leq (R1 + R2 + R3) * V_{UVP(min)} / V_{OC}$$

**Equation 6**

$$R2 + R3 \leq 51 * (R1 + R2 + R3) * V_{MPP(min)} / V_{EOC}$$



Finally, set the R3 considering the  $MPP_{RATIO}$  (in case of PV panels  $MPP_{RATIO} = V_{MP} / V_{OC}$ ):

#### Equation 7

$$MPP_{RATIO} = R3 / (R2 + R3)$$

In boost mode if the electrical characteristics of the selected source and battery are such that  $V_{OC-MAX} \leq V_{UVP(min)}$ , then the resistor R1 can be replaced by a short-circuit. Consequently, only R2 and R3 have to be selected for a proper setting of  $MPP_{RATIO}$ .

In a PV panel the  $V_{MPP}$  is typically within 70% ÷ 80% of  $V_{OC}$ .

In a TEG the  $V_{MPP}$  is typically about 50% of  $V_{OC}$ .

The MPPT accuracy can be strongly affected by an improper selection of the input capacitor. The input capacitance  $C_{IN} = 4.7 \mu F$  generally covers the most typical use cases.

The energy extracted from the harvested source, and stored in the input capacitance, is transferred to the load by the DC-DC converter through the inductor. The energy extracted by the inductor depends by the sink current: the higher input currents cause higher voltage drop on the input capacitance and this may result a problem for low voltage (< 1 V) and high energy (> 20 mA) sources. In such application cases the input capacitance has to be increased or, alternatively the L1 inductance has to be reduced.

During the  $T_{SAMPLE}$  time frame the input capacitor  $C_{IN}$  is charged up to  $V_{OC}$  by the source with a T1 time constant resulting from the capacitance and the equivalent resistance  $R_{EQ}$  of the source.

In case of the PV source, assuming  $I_{MPP}$  the minimum current at which the MPP must be guaranteed, the  $R_{EQ}$  can be calculated as following:

#### Equation 8

$$R_{EQ} = (V_{OC} - V_{MPP}) / I_{MPP} = V_{OC} \cdot (1 - MPP_{RATIO}) / I_{MPP}$$

Thus  $C_{IN}$  is calculated by the following formula:

#### Equation 9

$$C_{IN} \leq T1 / R_{EQ}$$

The following plots in [Figure 20](#) and [Figure 21](#) show the effect of different  $C_{IN}$  values on the time constant. If the capacitance is too high, the capacitor may not be charged within the  $T_{SAMPLE} = 400$  ms time window, thus affecting the MPPT accuracy.

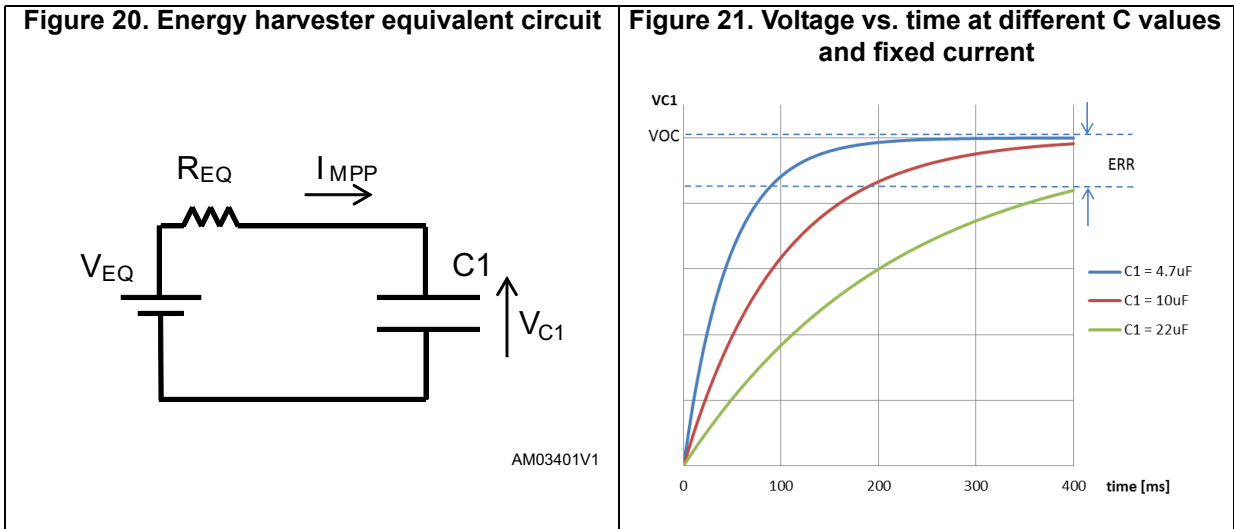

### 6.5 Power manager

The SPV1050 device works as a power manager also by providing one unregulated output voltage on the STORE pin and two regulated voltages on the LDO1 (1.8 V) and LDO2 (3.3 V) pins.

Each LDO can be selectively enabled or disabled by driving the related enable/disable pins LDO1\_EN and LDO2\_EN.

The performances of the LDOs can be optimized by selecting a proper capacitor between the LDO output pin and ground. A 100 nF for each LDO pin is suitable for the most typical use cases. [Figure 22](#) and [Figure 23](#) show the behavior of the LDOs when a 100 mA load is connected.

Figure 22. LDO1 turn on with 100 mA load

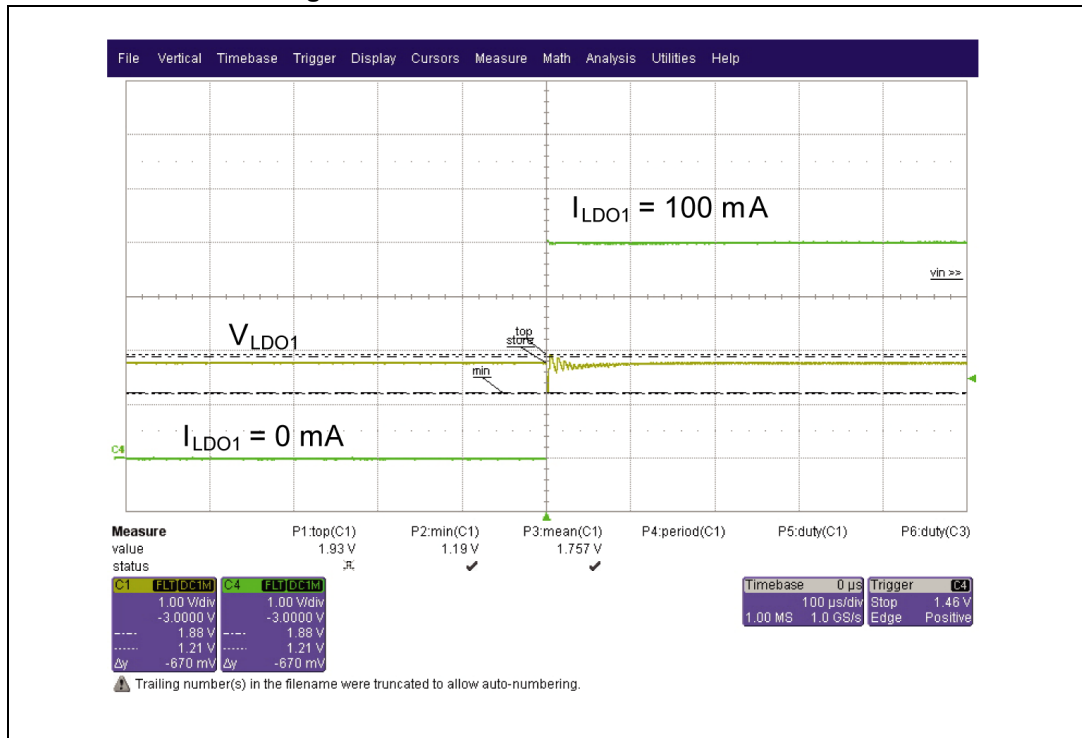
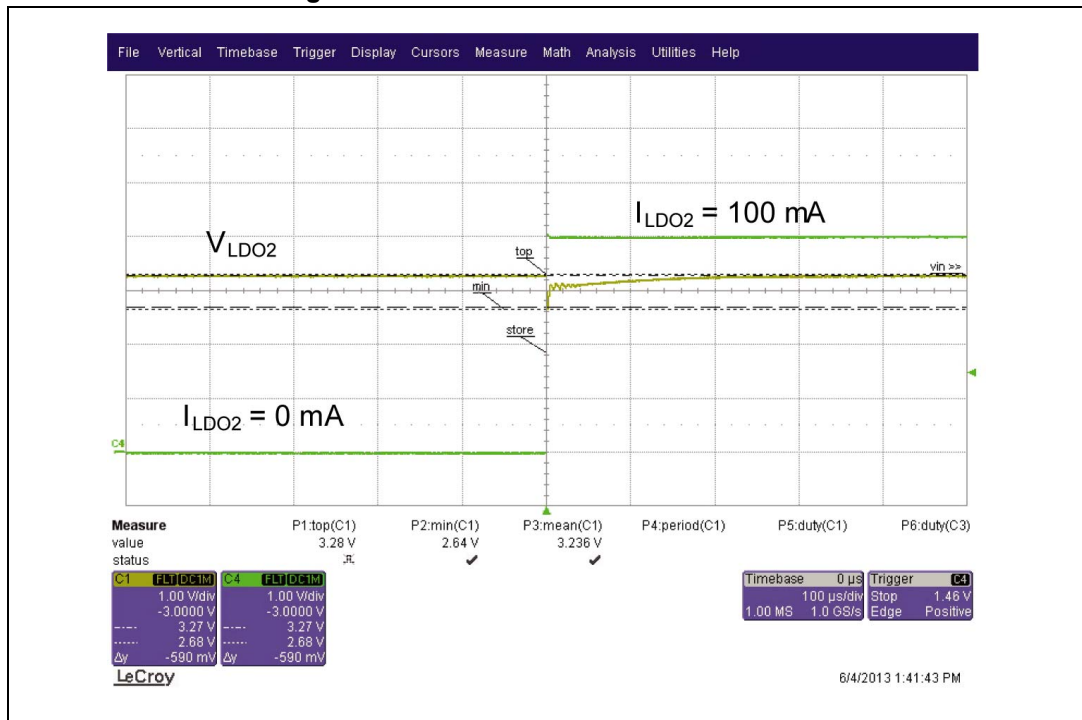

Figure 23. LDO2 turn on with 100 mA load



# 7 Package information

In order to meet environmental requirements, ST offers these devices in different grades of ECOPACK® packages, depending on their level of environmental compliance. ECOPACK specifications, grade definitions and product status are available at: [www.st.com](http://www.st.com). ECOPACK is an ST trademark.

## 7.1 VFQFPN20 3 x 3 x 1 mm - 20-lead pitch 0.4 package information

Figure 24. VFQFPN20 3 x 3 x 1 mm - 20-lead pitch 0.4 package outline

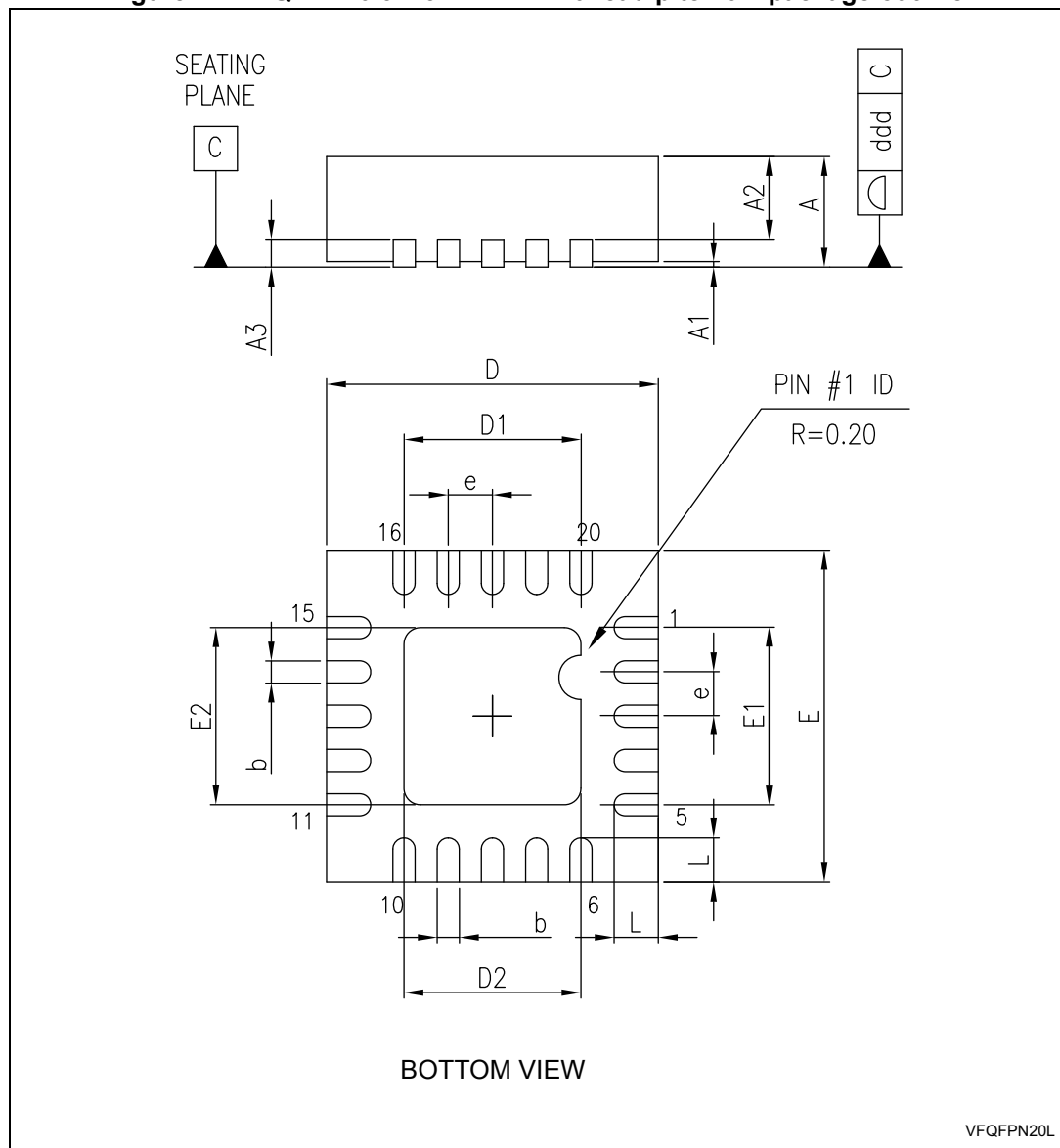

1. The pin #1 identifier must exist on the top surface of the package by using an indentation mark or another feature of the package body. Exact shape and size of this feature is optional.

Table 5. VFQFPN20 3 x 3 x 1 mm - 20-lead pitch 0.4 package mechanical data

Symbol	Dimensions (mm)			Note
	Min.	Typ.	Max.	
A	0.80	0.90	1.00	(1)
A1	-	0.02	0.05	
A2	-	0.65	1.00	
A3	-	0.20	-	
b	0.15	0.20	0.25	
D	2.85	3.00	3.15	
D1	-	1.60	-	
D2	1.50	1.60	1.70	
E	2.85	3.00	3.15	
E1	-	1.60	-	
E2	1.50	1.60	1.70	
e	0.35	0.40	0.45	
L	0.30	0.40	0.50	
ddd	-	-	0.07	

1. "VFQFPN" stands for "Thermally Enhanced Very thin Fine pitch Quad Packages No lead".  
Very thin:  $0.80 < A \leq 1.00$  mm / fine pitch:  $e < 1.00$  mm.

Figure 25. Die form pad position (top view)

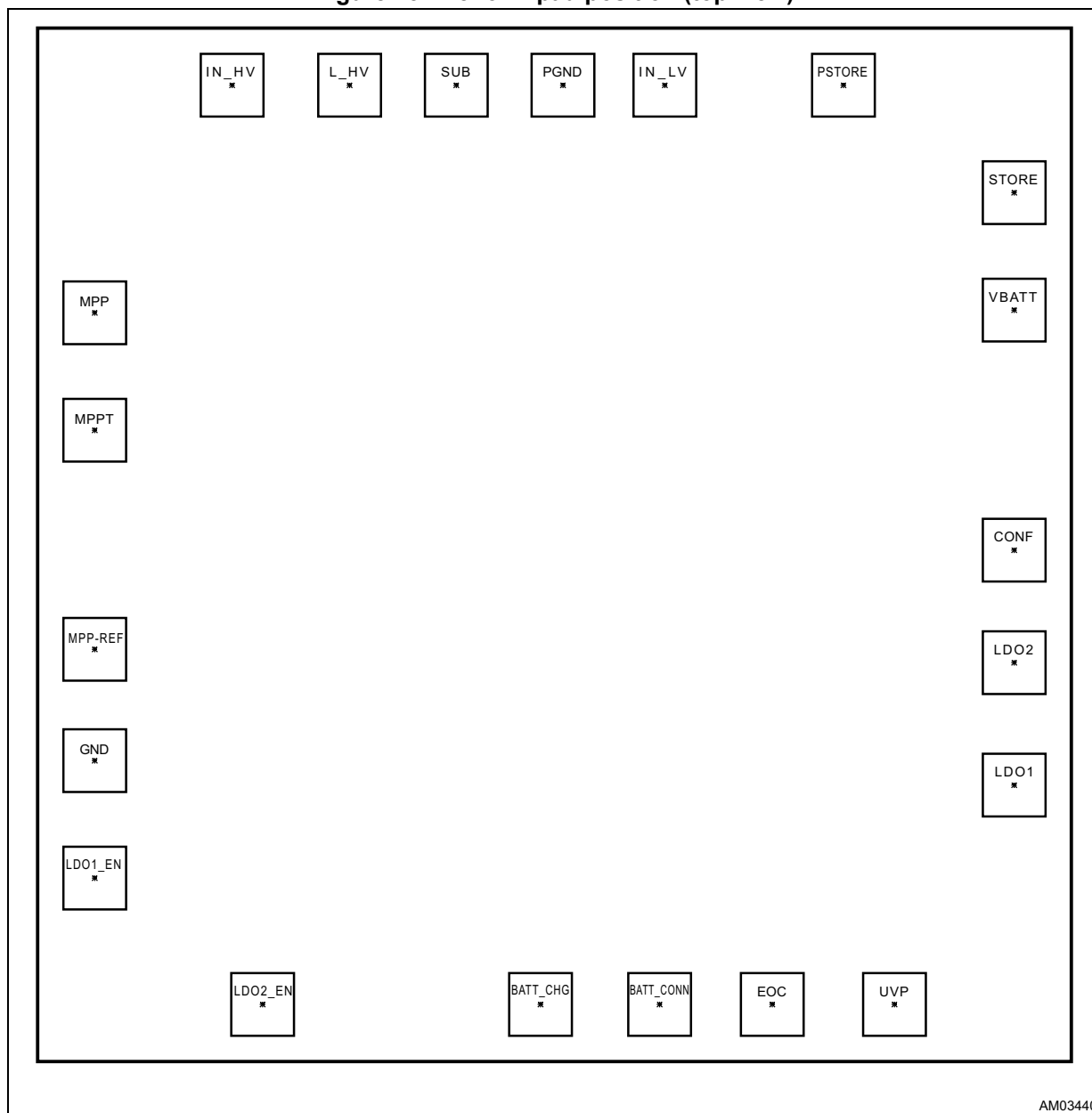
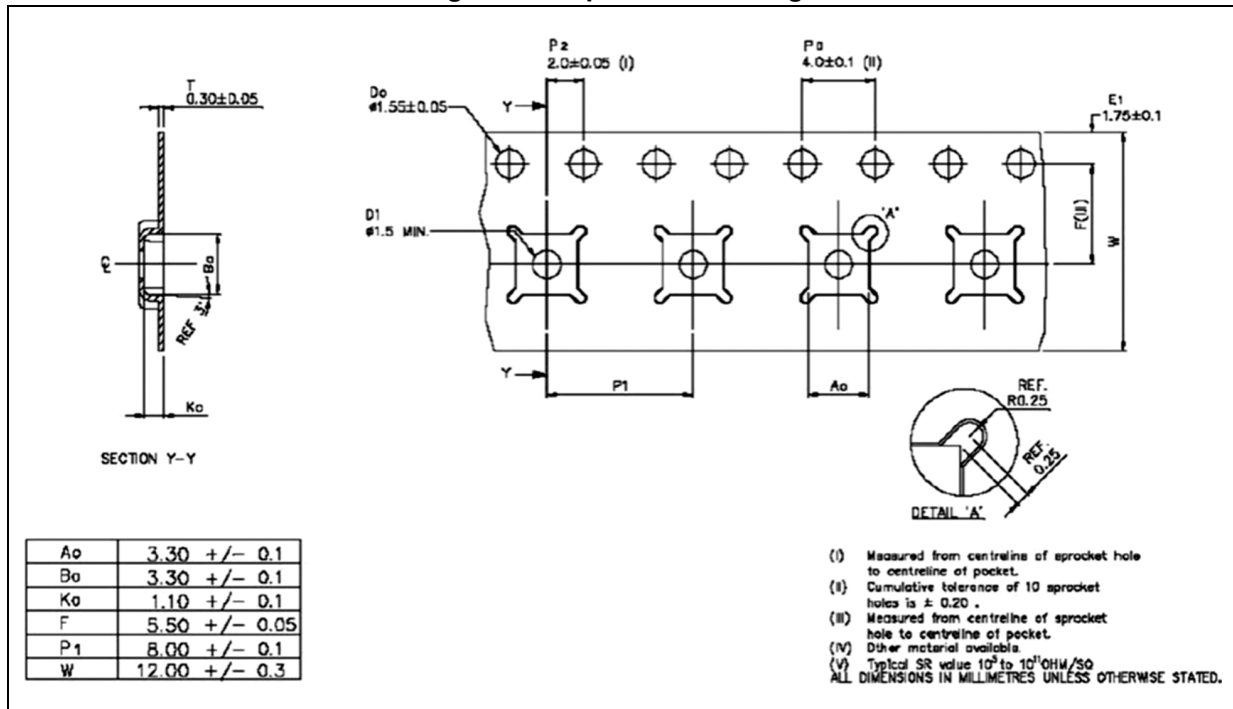

Table 6. Die pad coordinates and pad size

Pad name	X position [ $\mu\text{m}$ ]	Y position [ $\mu\text{m}$ ]	Pad dimension [ $\mu\text{m}$ ]
IN_HV	-416.55	594.09	81.05 x 81.05
L_HV	-264.75	594.09	
SUB	-126.87	594.09	
PGND	10.99	594.09	
IN_LV	142.65	594.09	
PSTORE	373.43	594.09	
STORE	594.09	455.22	
BATT	594.09	303.42	
CONF	594.09	-6.9	
LDO2	594.09	-152.33	
LDO1	594.09	-310.59	
UVP	439.39	-594.09	
EOC	281.45	-594.09	
BATT_OK	135.88	-594.09	
BATT_CHG	-18.03	-594.09	
LDO2_EN	-377.15	-594.09	
LDO1_EN	-594.09	-430.77	
GND	-594.09	-278.97	
MPP_REF	-594.09	-135.06	
MPP_SET	-594.09	148.12	
MPP	-594.09	299.92	

Figure 26. Tape and reel design



## 8 Ordering information

Table 7. Device summary

Order code	Op. temp. range (°C)	Package	Packing
SPV1050TTR	-40 to 85	VFQFPN 3 x 3 x 1 20L	Tape and reel
SPV1050-WST	-40 to 85	Die form	Sawn tested wafer



## Appendix A Application tips

In DC-DC converters the energy is transferred from the input to the output through the inductor. During the ON phase of the duty cycle, the inductor stores energy while during the OFF phase of the duty cycle, the energy is released toward the output stage.

**Figure 27. Inductor current and input voltage waveforms**

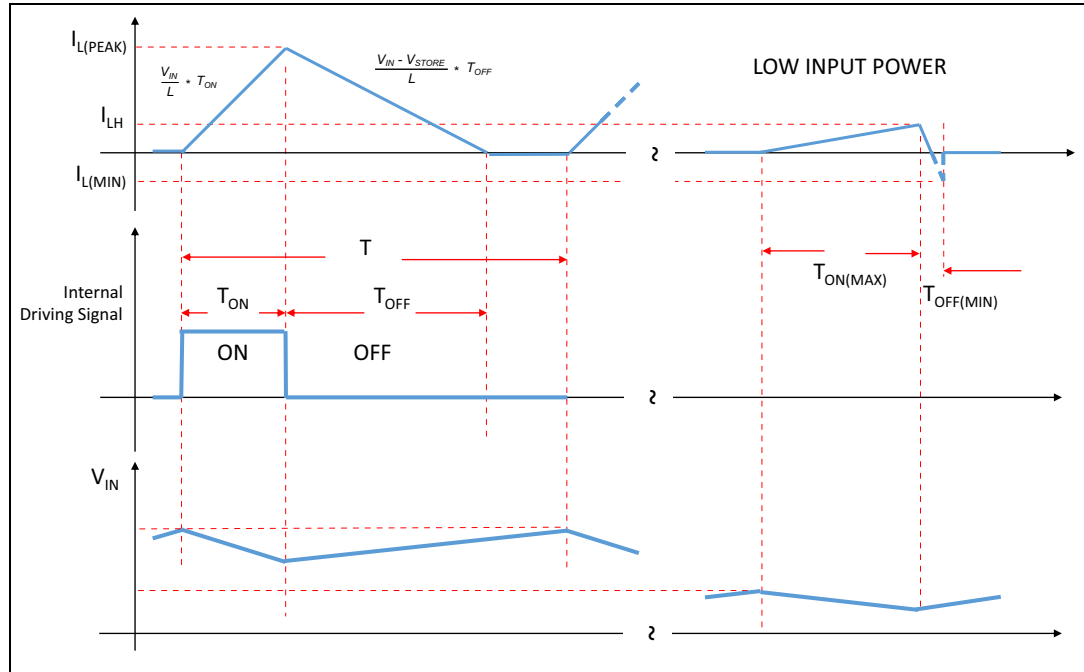

The SPV1050 controls the duty cycle of the driving signal by comparing the voltages on the MPP and MPP-REF pins. When  $V_{MPP}$  rises higher than  $V_{MPP-REF}$ , the IC switches ON and the inductor is loaded for  $T_{ON}$  until one of the following events occurs:

- $V_{STORE}$  triggers the EOC threshold
- The inductor current ( $I_L$ ) triggers the internal threshold  $I_{L(PEAK)}$  (= 140 mA, typ.)
- $T_{ON(MAX)} = 10 \mu s$  elapses

The energy stored in the inductor will be released to the output stage during the OFF phase. During  $T_{OFF}$ ,  $I_L$  decreases to 0 mA (all energy has been released). According to the internal controls of the IC,  $T_{OFF(MIN)} = 0.2 \mu s$  then, in order to prevent  $I_L$  becoming negative, the application must be designed such that the energy stored in the inductor during  $T_{ON}$  is always greater or equal to the energy released during  $T_{OFF}$ . This goal can be achieved through the proper selection of  $R2 + R3$ . Thus, in order to guarantee  $I_{L(MIN)} > 0$ , it must be:

**Equation 10**

$$I_{L(MIN)} = I_H - \frac{V_{STORE} - V_{IN}}{L} \times T_{OFF(MIN)} > 0$$

**Equation 11**

$$I_{L(MIN)} = \frac{V_{IN}}{L} \times T_{ON(MAX)} - \frac{V_{STORE} - V_{IN}}{L} \times T_{OFF(MIN)} > 0$$

Which leads to:

**Equation 12**

$$V_{IN} > V_{STORE} \times \frac{T_{OFF(MIN)}}{T_{ON(MAX)} + T_{OFF(MIN)}}$$

Finally, considering the worst case  $V_{STORE} = V_{EOC}$ , the minimum operating voltage  $V_{MPP} = V_{MPP(MIN)}$  and the resistor partitioning between  $V_{IN}$  and  $V_{MPP}$ :

**Equation 13**

$$(R_2 + R_3) = (R_1 + R_2 + R_3) \times \frac{V_{MPP(MIN)}}{V_{EOC}} \times \frac{T_{ON} + T_{OFF}}{T_{OFF}}$$

## 9 Revision history

**Table 8. Document revision history**

Date	Revision	Changes
25-Nov-2013	1	Initial release.
28-Aug-2014	2	Document status promoted from preliminary data to production data, with comprehensive update of electrical characteristics and graphic content throughout the document.
18-Dec-2014	3	Document status corrected to reflect current phase of product development.
06-Aug-2015	4	<ul style="list-style-type: none"> <li>– Minor text edits throughout the document.</li> <li>– Added maximum values for <math>R_{th\ j-c}</math> and <math>R_{th\ j-a}</math> in <i>Table 2: Thermal data</i>, with associated footnote.</li> <li>– Multiple changes to parameters, test conditions and values in <i>Table 4: Electrical characteristics</i>.</li> <li>– Modified text in <i>Section 6: Functional description</i> and <i>Section 6.4: MPPT setting</i></li> <li>– Removed order code SPV1050T from <i>Table 7: Device summary</i>, and modified package and packing values for order code SPV1050-WST.</li> <li>– Added <i>Appendix A: Application tips</i></li> </ul>
17-May-2018	5	<ul style="list-style-type: none"> <li>– Added <a href="#">Figure 26 on page 32</a>.</li> <li>– Minor modifications throughout the document</li> </ul>

**IMPORTANT NOTICE – PLEASE READ CAREFULLY**

STMicroelectronics NV and its subsidiaries ("ST") reserve the right to make changes, corrections, enhancements, modifications, and improvements to ST products and/or to this document at any time without notice. Purchasers should obtain the latest relevant information on ST products before placing orders. ST products are sold pursuant to ST's terms and conditions of sale in place at the time of order acknowledgement.

Purchasers are solely responsible for the choice, selection, and use of ST products and ST assumes no liability for application assistance or the design of Purchasers' products.

No license, express or implied, to any intellectual property right is granted by ST herein.

Resale of ST products with provisions different from the information set forth herein shall void any warranty granted by ST for such product.

ST and the ST logo are trademarks of ST. All other product or service names are the property of their respective owners.

Information in this document supersedes and replaces information previously supplied in any prior versions of this document.

© 2018 STMicroelectronics – All rights reserved