

© COPYRIGHT 1973 BY AMP INCORPORATED, HARRISBURG, PA. ALL INTERNATIONAL RIGHTS RESERVED. AMP INCORPORATED PRODUCTS COVERED BY U. S. AND FOREIGN PATENTS AND/OR PATENTS PENDING.

Unpublished copy not to be distributed without written permission

REVISIONS						
P	F	ZONE	LTR	DESCRIPTION	DATE	APPROVED
		A-1	A	-2 WAS GOLD PLATED FLANGE	3/7/75	M.P.
			B	ADDED .468 DIA., .38, .020, 1.437, ECN 8041, D.S.	5-19-75	M.P.
	✓		C	REMOVED -2 GOLD PIN-TIN FLANGE DS	5-19-78	M.P.
	✓		D	REV PER ECN 5-3960	4-13-87	R.S.
	✓		E	ADDED -5 PER NPR 2021	6-4-87	R.S. M.P.
	✓		F	OBS. -5 PER ECN DFO694	9-15-88	J.W.
			G	REVISED PER OH14-0192-05	1-06	PY

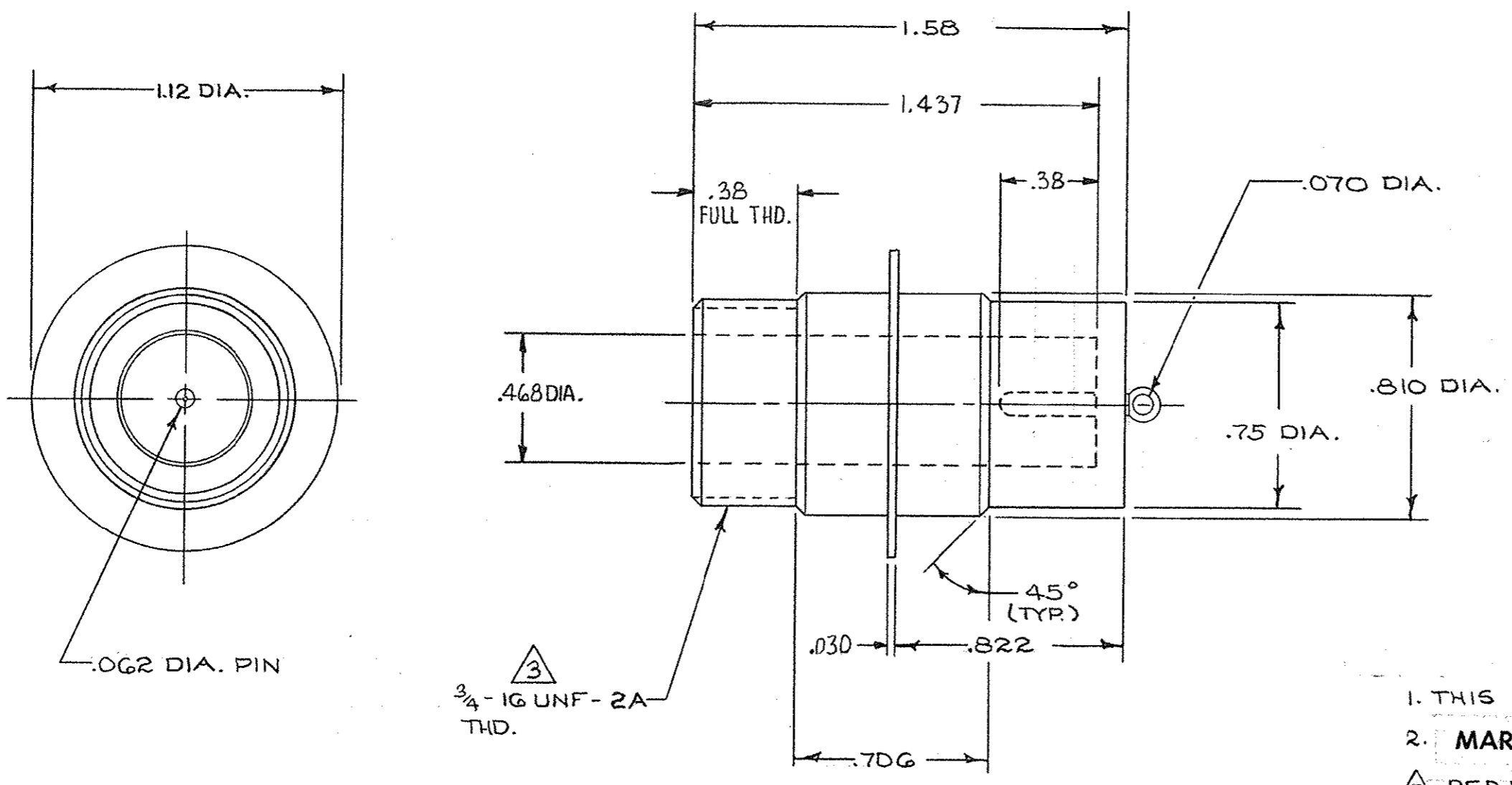

1. THIS RECEPTACLE IS HERMETICALLY SEALED
2. MARK PER AMP SPEC. 118-36000 (WHITE INK)
3. PER FEDERAL STANDARD H-28 3 WIRE METHOD. DIMENSION OVER WIRES TO BE: .7474-.7654.
4. 861256-5 IS SAME AS 861256-1 EXCEPT IT REQUIRES SPECIAL PACKAGING.

OBS	AS SHOWN WITH TIN PLATED PIN & FLANGE	5-861256-1
		861256-5
	AS SHOWN WITH TIN-LEAD PLATED PIN & FLANGE	861256-1
		PART NO

UNLESS OTHERWISE SPECIFIED DIMENSIONS ARE IN INCHES. TOLERANCES: .00 ±.02 .000 ±.010 ANGLES ±				CONTRACT NO		AMP INCORPORATED Elizabethtown, Pa.	
MATERIAL MOLDED GLASS EPOXY				DR D. Meyer 7/26/73			
FINISH BLACK				CHK		NAME RECEPTACLE, FLANGED LGH-2	
NEXT ASSY				APPD R.E. Fry 7-31-73		SIZE CODE IDENT NO NUMBER C 00779 861256	
FINAL ASSY				APPD		SCALE 2:1 WT SHEET / OF	
NEXT ASSY				DSGN APPD		OTHER APPD	
USED ON				OTHER APPD		UP-DATED	
QTY REQD				APPLICATION		CUSTOMER DRAWING	