

PART NUMBER	REVISION	DESCRIPTION	FEED TYPE
2266236-1	C	FINE CRIMP HEIGHT ADJUST	MECHANICAL
2266236-2	D	FINE CRIMP HEIGHT ADJUST	PNEUMATIC
7-2266236-1	C	MECHANICAL AND CRIMP TOOLING KIT	MECHANICAL
7-2266236-2	D	PNEUMATIC AND CRIMP TOOLING KIT	PNEUMATIC
7-2266236-7	B	CRIMP TOOLING KIT	-

ATLANTIC VERSION TERMINATOR INTERFACE ADAPTER



APPLICATOR DATA		
CRIMP	SIZE	TYPE
WIRE	2.29 mm (.090)	F
INSUL	-	-

APPLICATOR INSTRUCTIONS
408-35042

TERMINAL DATA: TE TERMINAL		TE CRIMP SPECIFICATION	
TERMINAL NAME: SPLICE			
WIRE STRIP LENGTH		INSULATION DIAMETER RANGE	
4.20-5.20 mm (.165-.205 IN)		∅ -	
TERMINAL APPLICATION SPECIFICATION		114-2088	-
TERMINALS APPLIED			
TE TERMINAL	TE TERMINAL	TE TERMINAL	TE TERMINAL
61769-1	61769-2	61769-3	

WIRE SIZE	CRIMP HEIGHT mm [INCH]	CRIMP HEIGHT REFERENCE SETTING
2550CMA	1.88+/-0.05 [.074 +/- .002]	5.5
1300CMA	1.68+/-0.05 [.066 +/- .002]	7.6

- RECOMMENDED SPARE PARTS
- REFER TO SUPPLIED INSTRUCTION SHEET FOR CLEANING, LUBRICATION AND STORAGE OF APPLICATOR.
- CRIMP HEIGHT REFERENCE SETTING WAS THE SETTING USED WHEN THE APPLICATOR WAS QUALIFIED AT THE FACTORY. ADJUSTMENT MAY BE NECESSARY WHEN RUNNING APPLICATOR IN THE FIELD.
- 4. FOR SETUP ONLY REFER TO TERMINAL CUSTOMER DRAWING FOR SPECIFIC CRIMP HEIGHT FORMULA.
- TERMINAL LUBRICATER IS RECOMMENDED.
- 6. UNLESS SPECIFIED OTHERWISE TORQUE VALUES SHALL BE USED PER DOCUMENT, 101-35000.

***WARNING**
ON INSTALLATION, SET WIRE DISC TO CRIMP HEIGHT REFERENCE SETTING FOR LARGEST WIRE SIZE. CRIMP HEIGHT REFERENCE SETTINGS GREATER THAN THE VALUE SHOWN MAY CAUSE DAMAGE TO THE CRIMP TOOLING, REFER TO THE INSTRUCTION SHEET FOR PROPER SETUP AND ADJUSTMENTS.

LOC	DIST	REVISIONS					
A	66	P	LTN	DESCRIPTION	DATE	DWN	APVD
		A		RELEASED	02APR2014	YY	UG
		B		ECR-17-010775	25JUL2017	KH	GB
		C		ECR-19-003090	26FEB2019	FJ	TE
		D		ECR-19-011338	19JUL2019	MZ	YY

-	1	1	1	1	1-690472-7	STRIPPER	261
-	1	-	1	-	2119641-1	FEED CAM, AIR FEED	248
-	1	1	1	1	7-18023-7	SCR, SKT HD CAP M3 X 4.0	241
-	-	1	-	1	2119580-1	MECHANICAL FEED ASSEMBLY	239
-	1	-	1	-	2844940-1	AIR FEED MODULE	238
-	REF	REF	REF	REF	994970-2	COUNTER, MAGNETIC	164
-	1	1	1	1	1-22281-8	SPRING, COMPRESSION	121
-	1	1	1	1	2119955-1	ASSY, LUBRICATOR, SIDE FEED	113
-	1	1	1	1	2844908-1	SCREW, LOCKING	99
-	1	1	1	1	2844907-1	POST, LOCKING	98
-	1	1	1	1	693855-8	FRONT STRIP GUIDE	96
-	2	2	2	2	2168083-1	SCR, SKT HD CAP, RoHS, M3 X 8.0	95
-	1	1	1	1	2168083-6	SCR, SKT HD CAP, RoHS, M5 X 65	93
-	1	1	1	1	455888-4	SPACER, CRIMPER	82
-	1	1	1	1	1803607-3	DOCUMENTATION PACKAGE	71
-	1	1	1	1	2119740-1	TAG, IDENTIFICATION	67
-	2	2	2	2	2168078-1	SCREW, DRIVE, RH, RoHS, 2 x .188	66
-	2	2	2	2	2-18032-5	SCR, SET, FLT PNT, M5 X 20.0	61
-	1	1	1	1	2168083-2	SCR, SKT HD CAP, RoHS, M4 X 8.0	60
-	1	1	1	1	5-18022-5	SCR, HEX HD CAP, M4 X 6.0	59
-	1	1	1	1	1338685-1	PAWL, FEED	56
-	2	2	2	2	2168083-3	SCR, SKT HD CAP, RoHS, M4 X 12.0	54
-	1	2	1	2	18023-9	SCR, SKT HD CAP M4 X 6.0	49
-	-	1	-	1	2119652-1	FEED CAM, PRE FEED	48
-	-	1	-	1	2119653-1	FEED CAM, POST FEED	47
-	1	1	1	1	2-1803583-3	APPLICATOR BASIC ASSEMBLY, SF	46
-	1	1	1	1	1803515-1	RAM ASSEMBLY, SF ATLANTIC	44
-	1	1	1	1	1803602-1	SCR, BHSC, RoHS (M8 X 25)	41
-	2	2	2	2	2079383-5	SCR, BHSC, RoHS (M4 X 20)	33
-	2	2	2	2	2-2844962-0	SPACER, CYLINDRICAL, STRIP GUIDE	30
-	1	1	1	1	2844938-1	PLATE, STRIP GUIDE	29
-	1	1	1	1	1-455888-0	SPACER, CRIMPER	28
-	2	2	2	2	22283-1	SPRING, COMPRESSION	27
-	1	1	1	1	356835-1	LEVER, DRAG RELEASE	26
-	1	1	1	1	240792-3	DRAG, TERMINAL	25
-	1	1	1	1	1320928-2	STRIP GUIDE	24
-	1	1	1	1	980371-4	SCR, SKT HD SHLDR 5.0 DIA X 6.0	23
-	2	2	2	2	2168083-2	SCR, SKT HD CAP, RoHS, M4 X 8.0	21
-	3	3	3	3	1-18028-2	WASHER, FLAT, REG M4	20
-	1	1	1	1	2119533-1	STRIPPER, SIDE FEED	19
-	1	1	1	1	2119806-1	INSERT, SHEAR	13
-	1	1	1	1	3-22280-3	SPRING, COMPRESSION	12
-	1	1	1	1	1-356885-4	STOP, SHEAR	11
-	1	1	1	1	2119805-1	SHEAR HOLDER, FRONT	10
-	1	1	1	1	454276-5	FLOATING SHEAR, FRONT	9
-	1	2	2	1	1803412-5	ANVIL, COMBINATION	8
-	-	-	-	-	-	-	7
-	-	-	-	-	-	-	6
-	1	1	1	1	2119757-8	DEPRESSOR, SHEAR	5
-	-	-	-	-	-	-	4
-	-	-	-	-	-	-	3
-	-	-	-	-	-	-	2
-	1	2	2	1	1803504-4	CRIMPER, WIRE	1

ATLANTIC VERSION
Shown on sheets 1 of 4 & 2 of 4
(Pacific version shown on sheets 3 of 4 & 4 of 4)

DIMENSIONS:		TOLERANCES UNLESS OTHERWISE SPECIFIED:		MATERIAL:		FINISH:	
mm	0 PLC ±	1 PLC ±	2 PLC ±	3 PLC ±	4 PLC ±	ANGLES	

CHK	STAKEM	18MAR2014	
CHK	G. BAILEY	18MAR2014	
APVD	T. ELBIN	18MAR2014	
NAME		Ocean Side Feed Applicator	
SIZE	CAGE CODE	DRAWING NO	RESTRICTED TO
A1	00779	2266236	
Customer Accessible Production Drawing		SCALE	1:2
SHEET		1	OF 4
REV		D	

LOC		DIST		REVISIONS			
NO.	REV.	DATE	BY	DESCRIPTION	DATE	BY	APPROV.
A	66			SEE SHEET 1			

FEED TYPE MECHANICAL

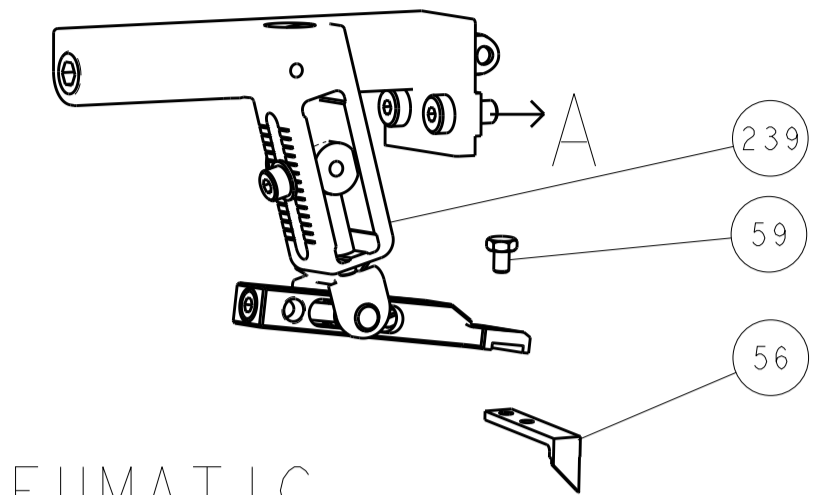

PNEUMATIC

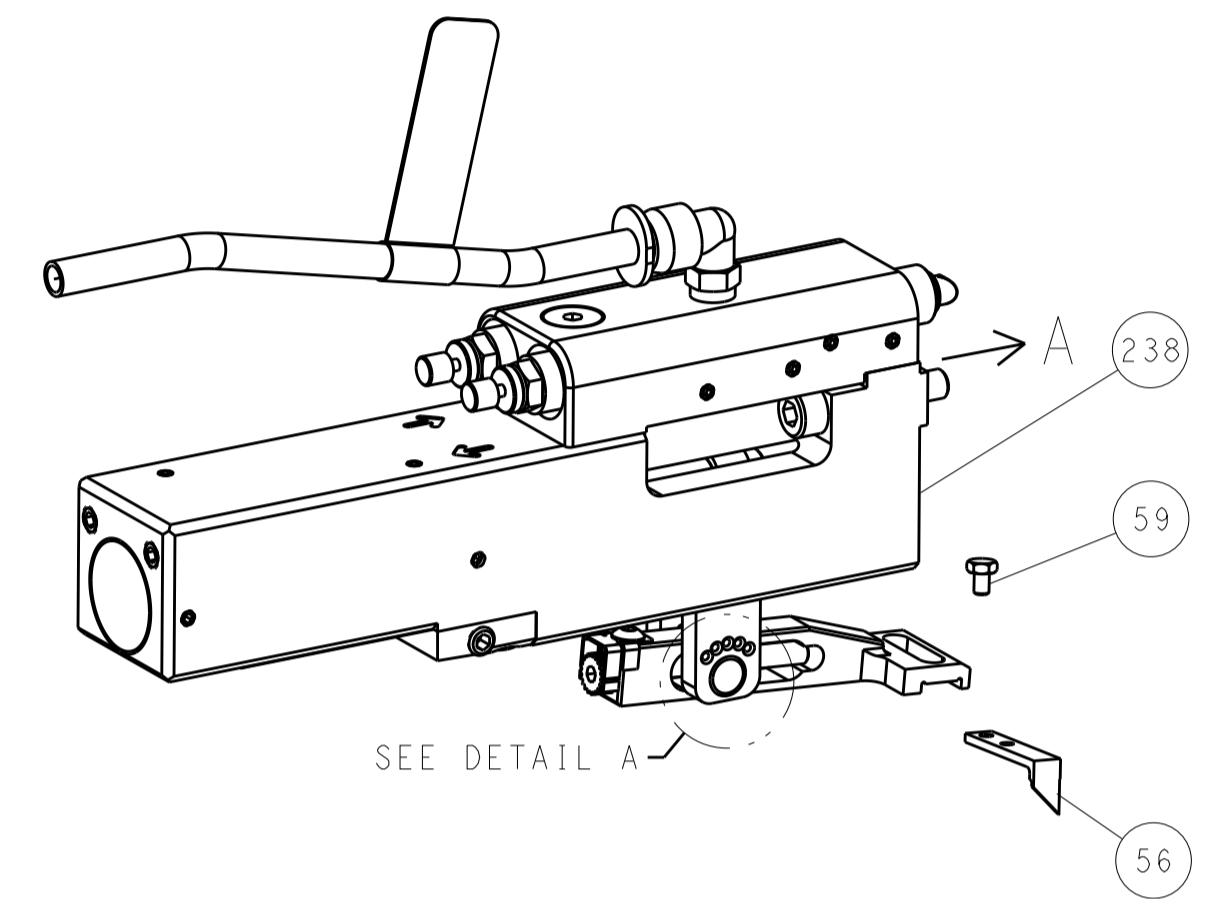

FEED SPRING SETTING POSITION (SHOWN FROM REAR SIDE)

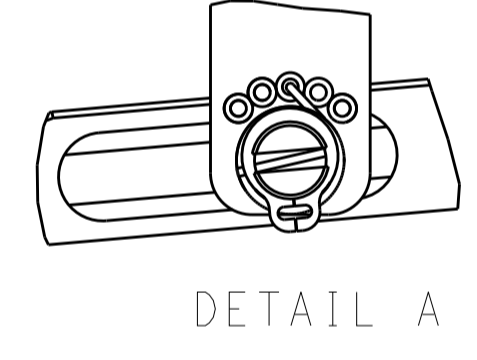

DETAIL A

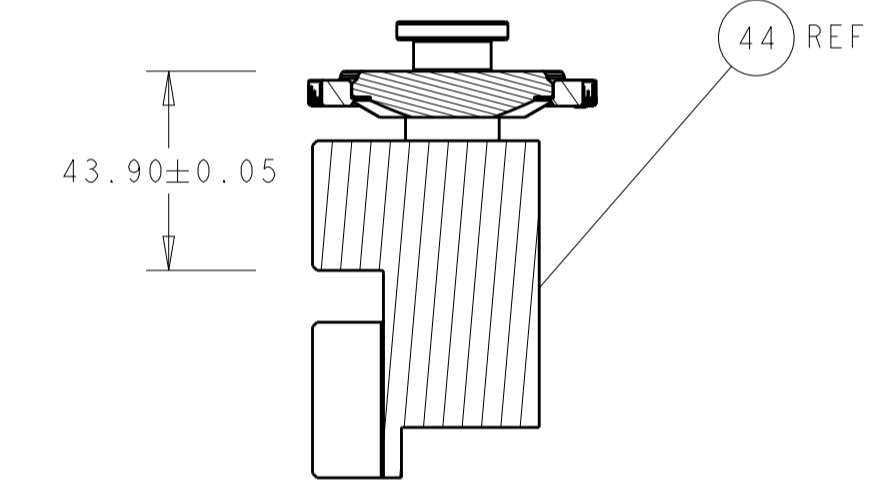
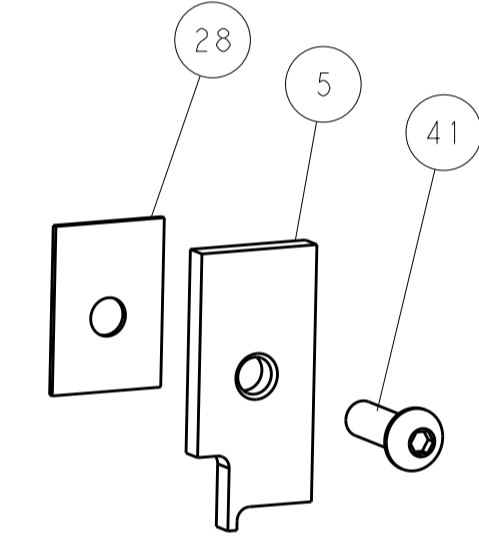
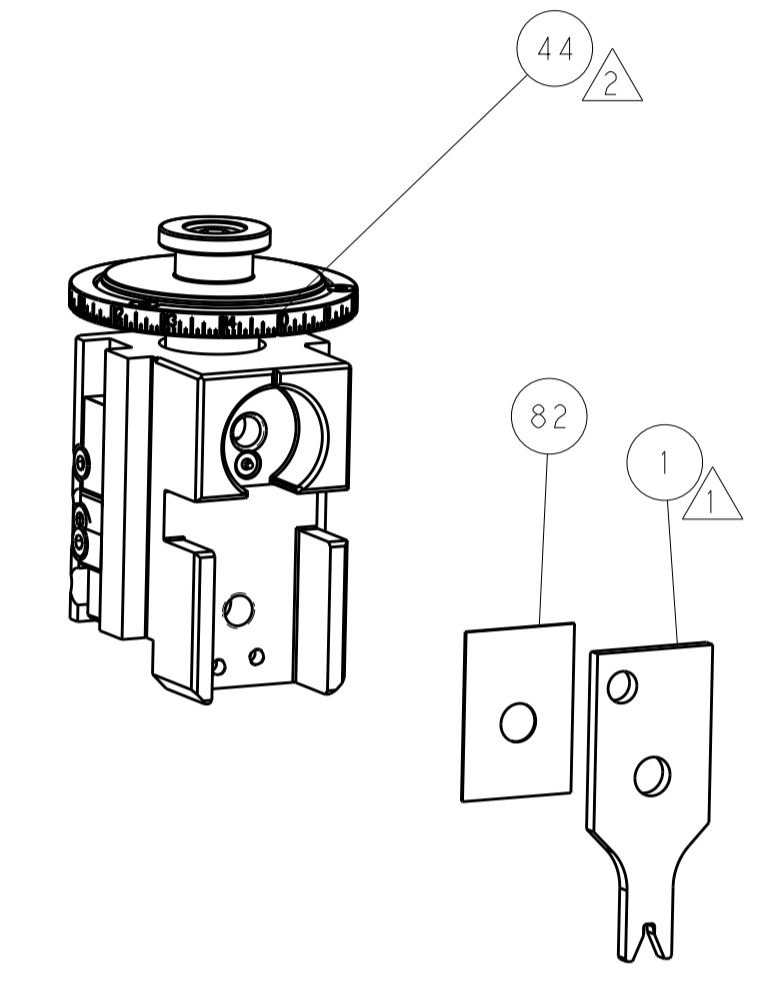

RAM SET-UP

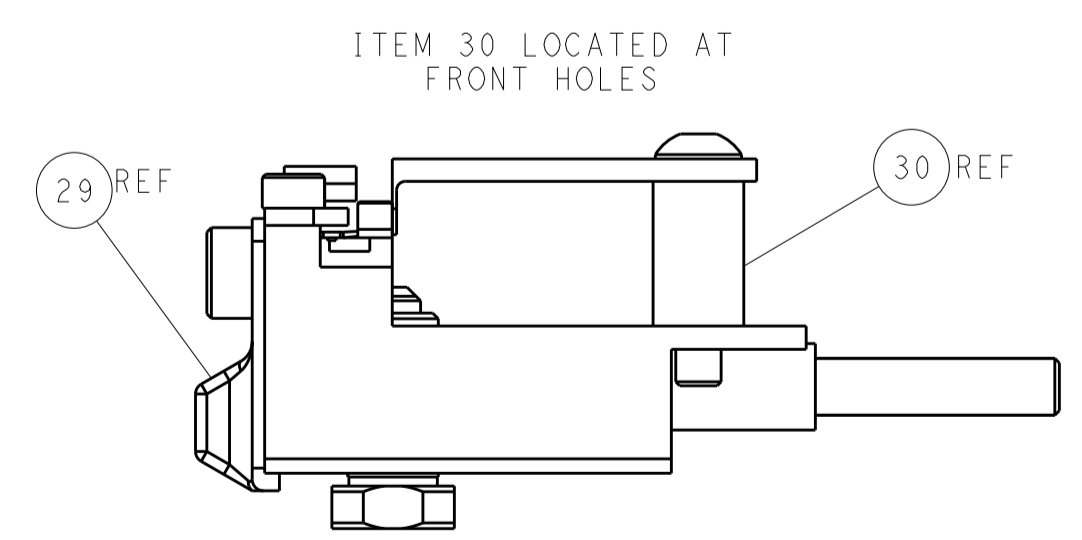
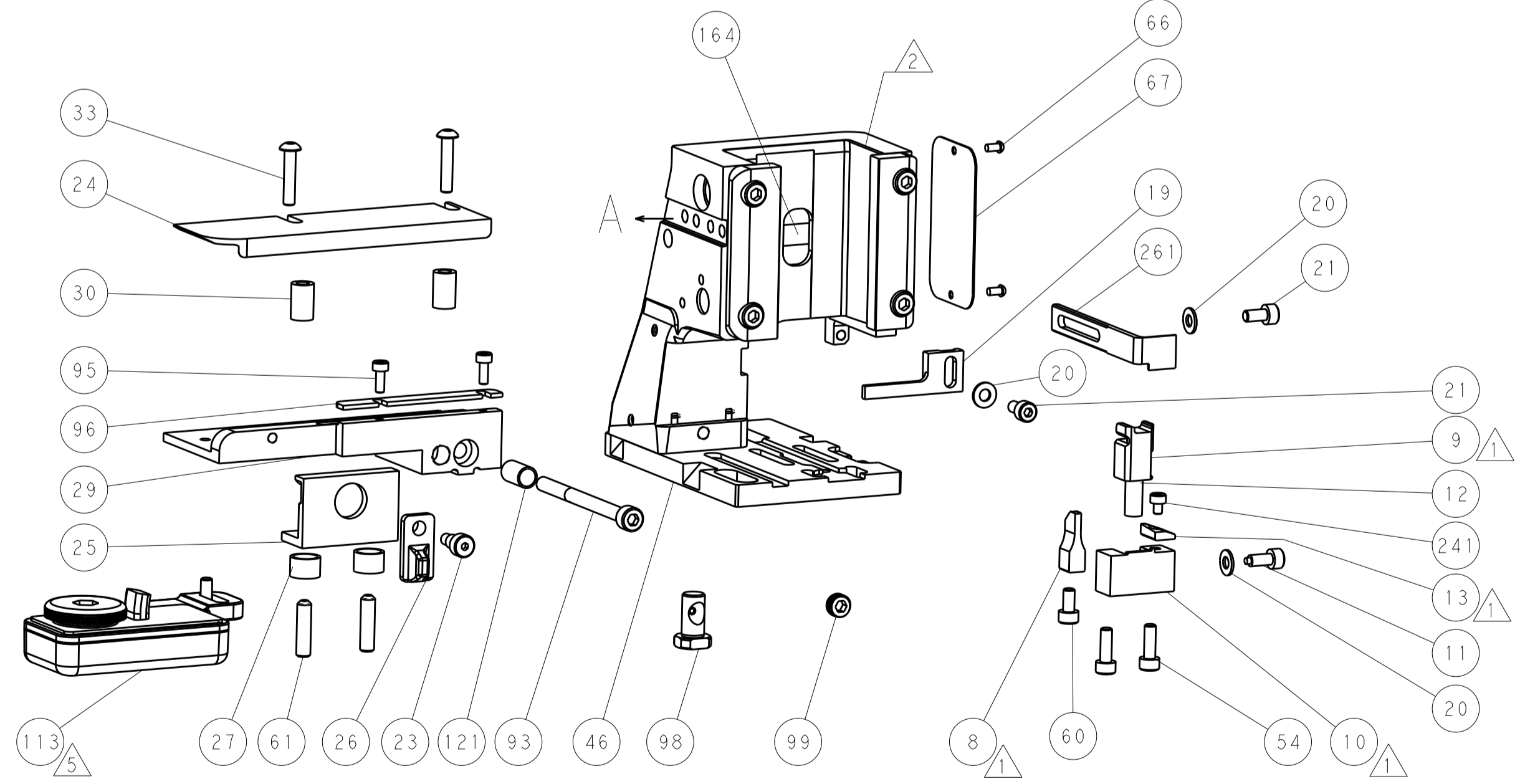

FEED TRACK POSITION GUIDE BEHIND WIRE BARREL

CAM POSITIONS

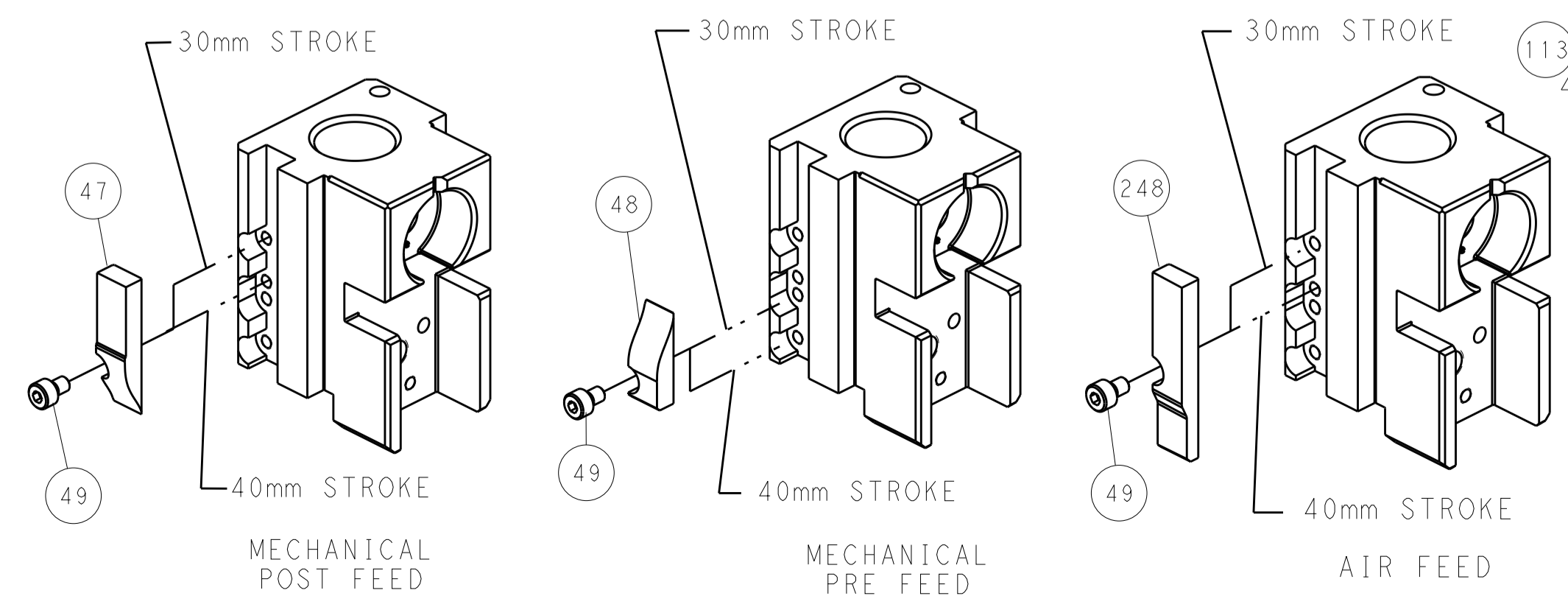

ATLANTIC VERSION
 Shown on sheets 1 of 4 & 2 of 4
 (Pacific version shown on sheets 3 of 4 & 4 of 4)

DIMENSIONS:		TOLERANCES UNLESS OTHERWISE SPECIFIED:		DWG: STAKEM 18MAR2014		TE Connectivity	
mm	0 PLC ±	1 PLC ±	2 PLC ±	3 PLC ±	4 PLC ±	NAME: Ocean Side Feed Applicator	Harrisburg, PA 17105-3608
MATERIAL:		FINISH:		APVD: T. ELBIN 18MAR2014		SIZE: A1	
				WEIGHT:		CAGE CODE: 00779	
				Customer Accessible Production Drawing		SCALE: 1:2 SHEET 2 OF 4 REV D	

PART NUMBER	REVISION	DESCRIPTION	FEED TYPE
2-2266236-1	C	FINE CRIMP HEIGHT ADJUST	MECHANICAL
2-2266236-2	D	FINE CRIMP HEIGHT ADJUST	PNEUMATIC
7-2266236-7	B	CRIMP TOOLING KIT	-

PACIFIC VERSION TERMINATOR
 INTERFACE ADAPTER



APPLICATOR DATA		
CRIMP	SIZE	TYPE
WIRE	2.29 mm [.090]	F
INSUL	-	-

APPLICATOR INSTRUCTIONS
 408-35042

TERMINAL DATA: TE TERMINAL		TE CRIMP SPECIFICATION	
TERMINAL NAME: SPLICE			
WIRE STRIP LENGTH 4.20-5.20 mm [.165-.205 IN]		INSULATION DIAMETER RANGE Ø -	
TERMINAL APPLICATION SPECIFICATION 114-2088	-	-	-
TERMINALS APPLIED			
TE TERMINAL 61769-1	TE TERMINAL 61769-2	TE TERMINAL 61769-3	TE TERMINAL

WIRE SIZE	CRIMP HEIGHT mm [INCH]	CRIMP HEIGHT REFERENCE SETTING
2550CMA	1.88+/-0.05 [.074 +/- .002]	5.5
1300CMA	1.68+/-0.05 [.066 +/- .002]	7.6



- RECOMMENDED SPARE PARTS
- REFER TO SUPPLIED INSTRUCTION SHEET FOR CLEANING, LUBRICATION AND STORAGE OF APPLICATOR.
- CRIMP HEIGHT REFERENCE SETTING WAS THE SETTING USED WHEN THE APPLICATOR WAS QUALIFIED AT THE FACTORY. ADJUSTMENT MAY BE NECESSARY WHEN RUNNING APPLICATOR IN THE FIELD.
- FOR SETUP ONLY REFER TO TERMINAL CUSTOMER DRAWING FOR SPECIFIC CRIMP HEIGHT FORMULA.
- TERMINAL LUBRICATER IS RECOMMENDED.
- UNLESS SPECIFIED OTHERWISE TORQUE VALUES SHALL BE USED PER DOCUMENT, 101-35000.

***WARNING**
 ON INSTALLATION, SET WIRE DISC TO CRIMP HEIGHT REFERENCE SETTING FOR LARGEST WIRE SIZE. CRIMP HEIGHT REFERENCE SETTINGS GREATER THAN THE VALUE SHOWN MAY CAUSE DAMAGE TO THE CRIMP TOOLING, REFER TO THE INSTRUCTION SHEET FOR PROPER SETUP AND ADJUSTMENTS.

PACIFIC VERSION
 Shown on sheets 3 of 4 & 4 of 4
 (Atlantic version shown on sheets 1 of 4 & 2 of 4)

LOC	DIST	REVISIONS					
A	66	P	LTN	DESCRIPTION	DATE	OWN	APVD
-	-	-	-	SEE SHEET 1	-	-	-

-	1	1	1-690472-7	STRIPPER	261
-	1	1	7-18023-7	SCR, SKT HD CAP M3 X 4.0	241
-	-	1	2119580-1	MECHANICAL FEED ASSEMBLY	239
-	1	-	2844940-1	AIR FEED MODULE	238
-	REF	REF	994970-2	COUNTER, MAGNETIC	164
-	1	-	2119641-2	FEED CAM, AIR FEED	151
-	1	1	2168083-8	SCR, SKT HD CAP, RoHS, M4 X 16	144
-	2	2	2168083-9	SCR, SKT HD CAP, RoHS, M4 X 20	143
-	-	1	2119653-2	FEED CAM, POST FEED	142
-	1	1	2-1803583-4	APPLICATOR BASIC ASSEMBLY, SF	141
-	1	1	1803516-1	RAM ASSEMBLY, SF PACIFIC	140
-	1	1	1-22281-8	SPRING, COMPRESSION	121
-	1	1	2119955-1	ASSY, LUBRICATOR, SIDE FEED	113
-	1	1	2844908-1	SCREW, LOCKING	99
-	1	1	2844907-1	POST, LOCKING	98
-	1	1	693855-8	FRONT STRIP GUIDE	96
-	2	2	2168083-1	SCR, SKT HD CAP, RoHS, M3 X 8.0	95
-	1	1	2168083-6	SCR, SKT HD CAP, RoHS, M5 X 65	93
-	1	1	455888-4	SPACER, CRIMPER	82
-	1	1	1803607-3	DOCUMENTATION PACKAGE	71
-	1	1	2119740-1	TAG, IDENTIFICATION	67
-	2	2	2168078-1	SCREW, DRIVE, RH, RoHS, 2 x .188	66
-	2	2	2-18032-5	SCR, SET, FLT PNT, M5 X 20.0	61
-	1	1	5-18022-5	SCR, HEX HD CAP, M4 X 6.0	59
-	1	1	1338685-1	PAWL, FEED	56
-	1	2	18023-9	SCR, SKT HD CAP M4 X 6.0	49
-	-	1	2119652-1	FEED CAM, PRE FEED	48
-	1	1	1803602-1	SCR, BHSC, RoHS (M8 X 25)	41
-	2	2	2079383-5	SCR, BHSC, RoHS (M4 X 20)	33
-	2	2	2-2844962-0	SPACER, CYLINDRICAL, STRIP GUIDE	30
-	1	1	2844938-1	PLATE, STRIP GUIDE	29
-	1	1	1-455888-0	SPACER, CRIMPER	28
-	2	2	22283-1	SPRING, COMPRESSION	27
-	1	1	356835-1	LEVER, DRAG RELEASE	26
-	1	1	240792-3	DRAG, TERMINAL	25
-	1	1	1320928-2	STRIP GUIDE	24
-	1	1	980371-4	SCR, SKT HD SHLDR 5.0 DIA X 6.0	23
-	2	2	2168083-2	SCR, SKT HD CAP, RoHS, M4 X 8.0	21
-	3	3	1-18028-2	WASHER, FLAT, REG M4	20
-	1	1	2119533-1	STRIPPER, SIDE FEED	19
-	1	1	2119806-1	INSERT, SHEAR	13
-	1	1	3-22280-3	SPRING, COMPRESSION	12
-	1	1	1-356885-4	STOP, SHEAR	11
-	1	1	2119805-1	SHEAR HOLDER, FRONT	10
-	1	1	454276-5	FLOATING SHEAR, FRONT	9
-	1	1	1803412-5	ANVIL, COMBINATION	8
-	-	-	-	-	7
-	-	-	-	-	6
-	1	1	2119757-8	DEPRESSOR, SHEAR	5
-	-	-	-	-	4
-	-	-	-	-	3
-	-	-	-	-	2
-	1	1	1803504-4	CRIMPER, WIRE	1

DIMENSIONS:		TOLERANCES UNLESS OTHERWISE SPECIFIED:		MATERIAL:		FINISH:	
mm	0 PLC ±	1 PLC ±	2 PLC ±	3 PLC ±	4 PLC ±	ANGLES	FINISH

CHK	DATE	NAME	SIZE	CAGE CODE	DRAWING NO	RESTRICTED TO
CHK	18MAR2014	STAKEM	A1	00779	2266236	-
CHK	18MAR2014	G. BAILEY				
APVD	18MAR2014	ELBIN				

Customer Accessible Production Drawing SCALE 1:2 SHEET 3 OF 4 REV D

LOC		DIST		REVISIONS			
A	66	P	LTM	DESCRIPTION	DATE	DWN	APVD
		-		SEE SHEET 1			

FEED TYPE MECHANICAL



PNEUMATIC

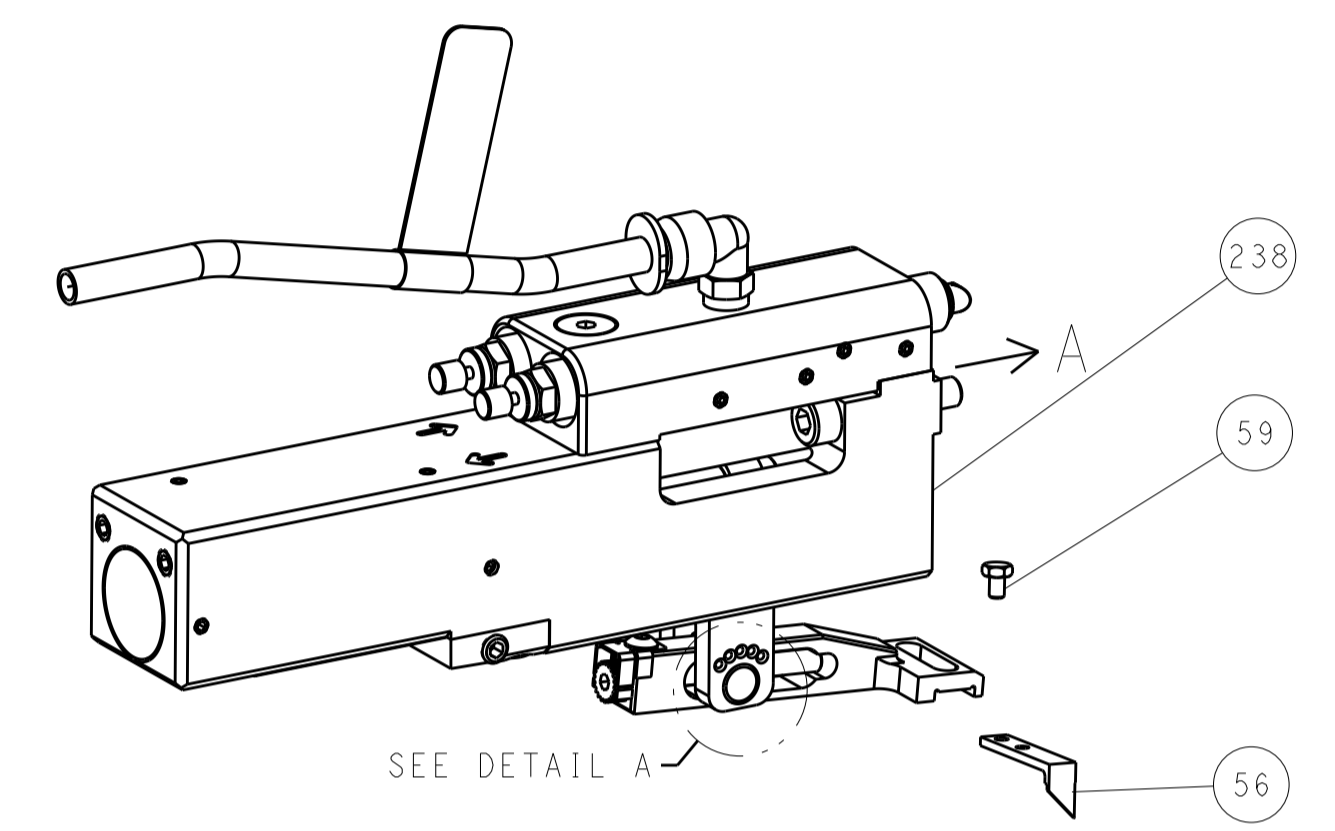

FEED SPRING SETTING POSITION (SHOWN FROM REAR SIDE)

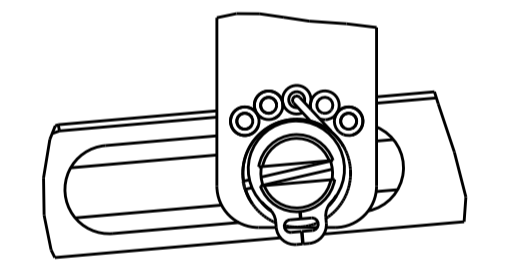

DETAIL A

CAM POSITIONS

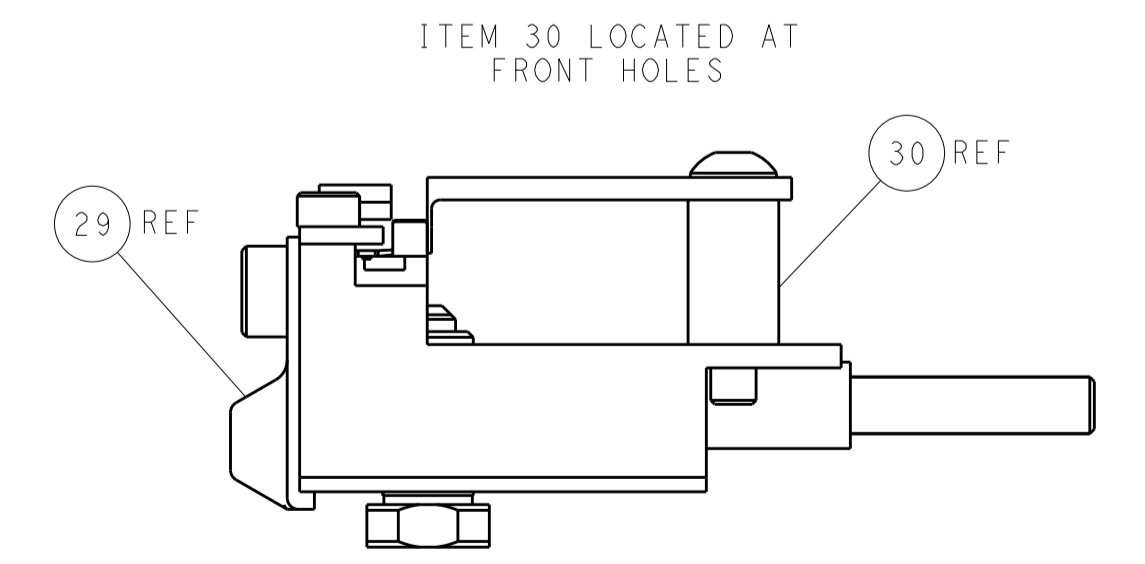
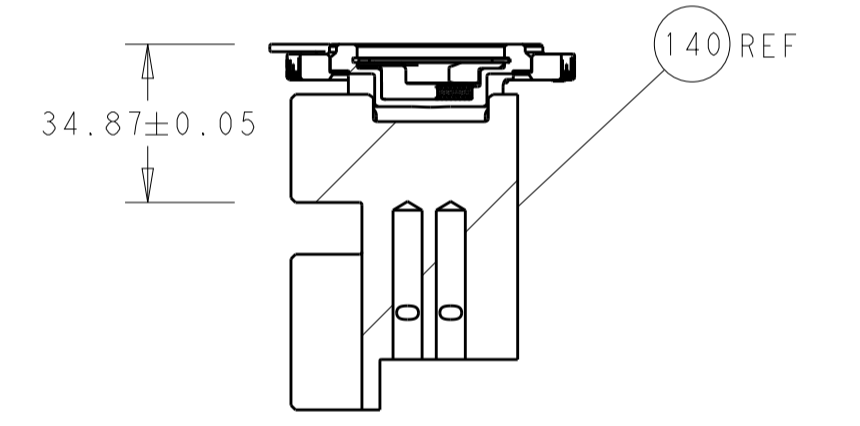
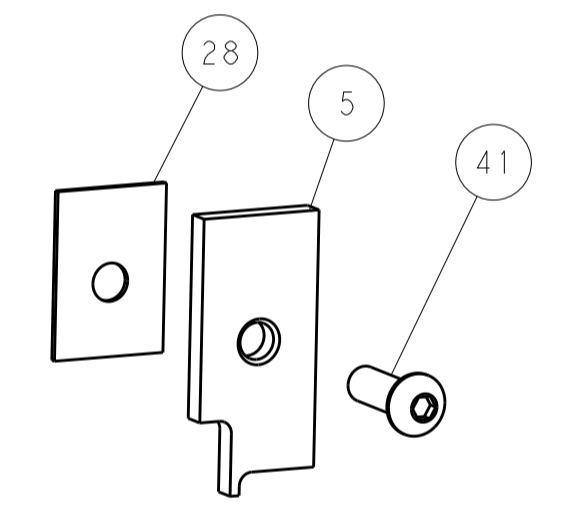
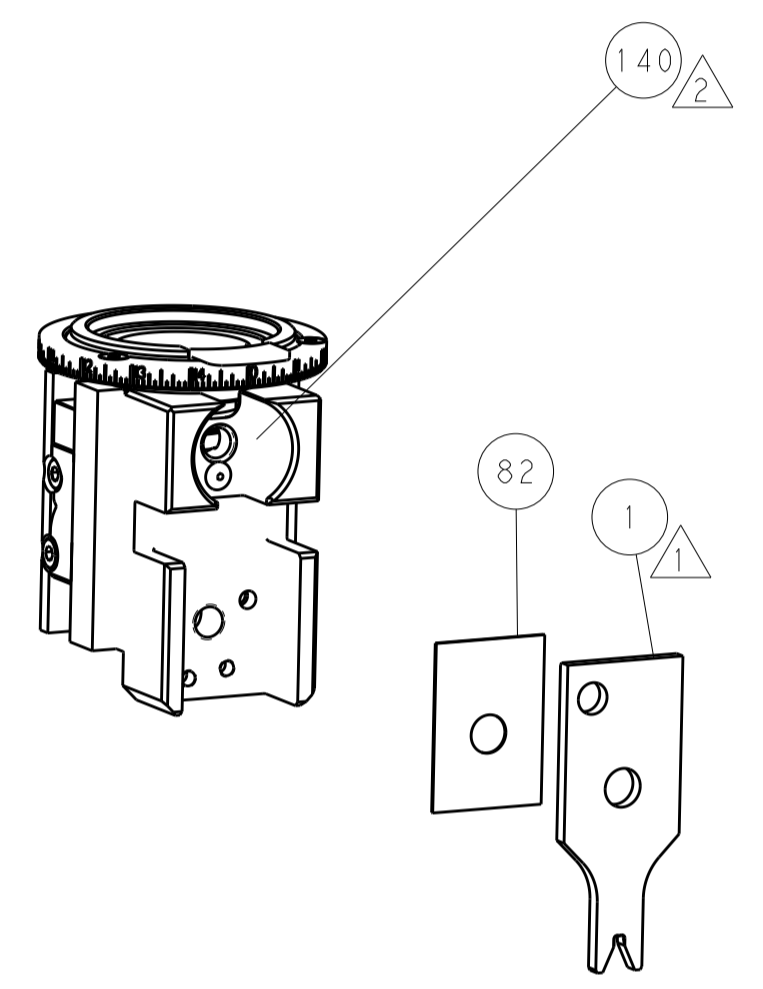
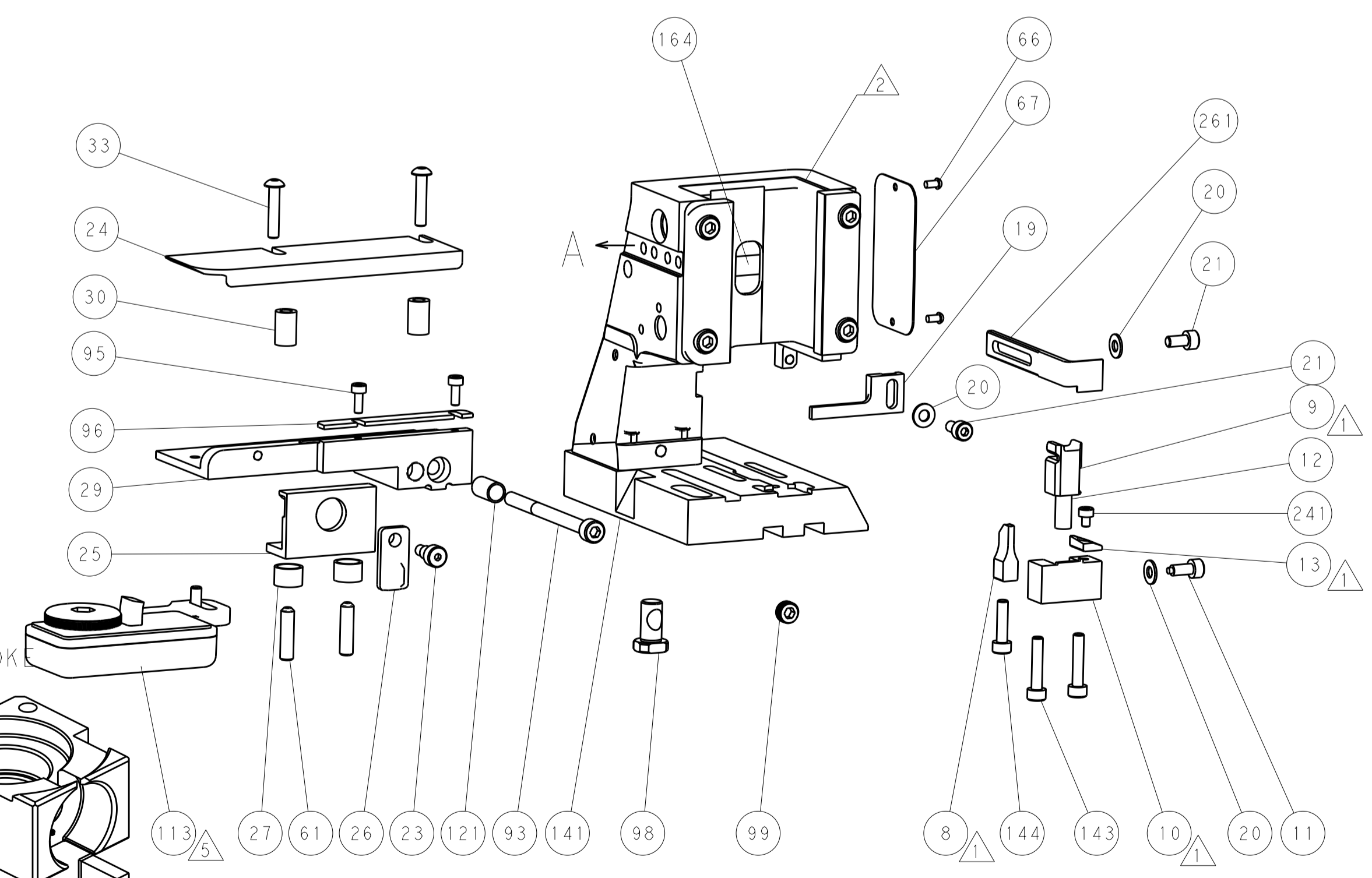
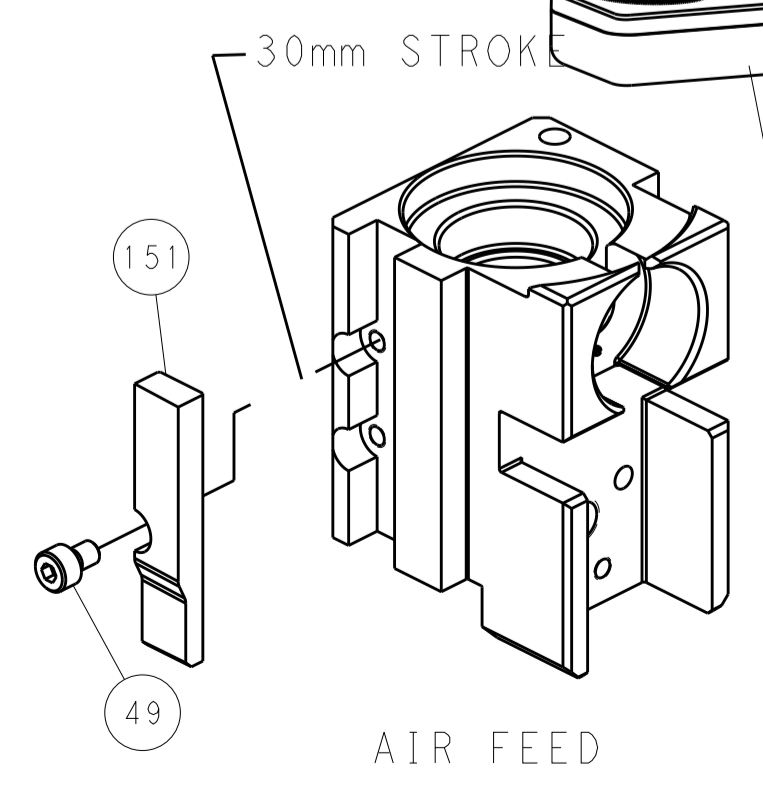
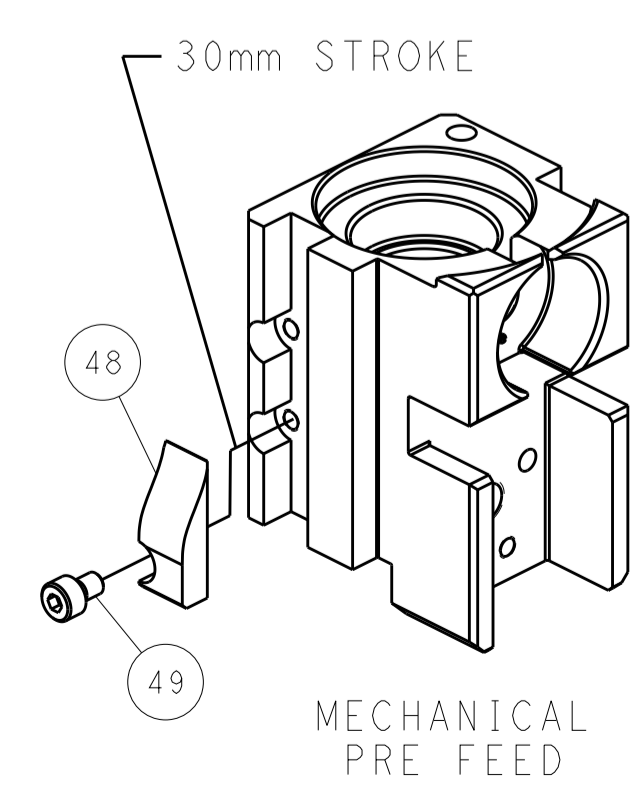
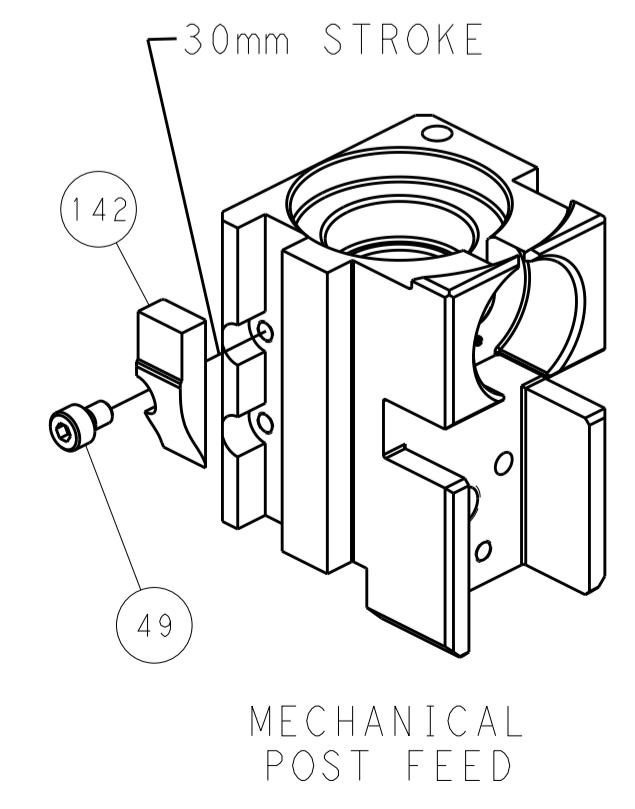

PACIFIC VERSION
 Shown on sheets 3 of 4 & 4 of 4
 (Atlantic version shown on sheets 1 of 4 & 2 of 4)

DIMENSIONS:		TOLERANCES UNLESS OTHERWISE SPECIFIED:		DWN: R. STAKEM 18MAR2014		TE Connectivity	
mm	0 PLC ±	1 PLC ±	2 PLC ±	3 PLC ±	4 PLC ±	5 PLC ±	Harrisburg, PA 17105-3608
MATERIAL:		FINISH:		CHK: G. BAILEY 18MAR2014		NAME: Ocean Side Feed Applicator	
				APVD: T. ERLIN 18MAR2014		SIZE: CAGE CODE: DRAWING NO: A1 00779 C=2266236	
				PRODUCT SPEC:		RESTRICTED TO:	
				APPLICATION SPEC:		Customer Accessible Production Drawing	
				WEIGHT:		SCALE: 1:2 SHEET 4 OF 4 REV D	