

THIS DRAWING IS UNPUBLISHED. RELEASED FOR PUBLICATION
 © COPYRIGHT BY TYCO ELECTRONICS CORPORATION. ALL RIGHTS RESERVED.

LOC		DIST		REVISIONS			
P	LTR	DESCRIPTION		DATE	DWN	APVD	
AF	50	B	REVISED PER ECR-06-010412	02NOV06	HMR	KR	

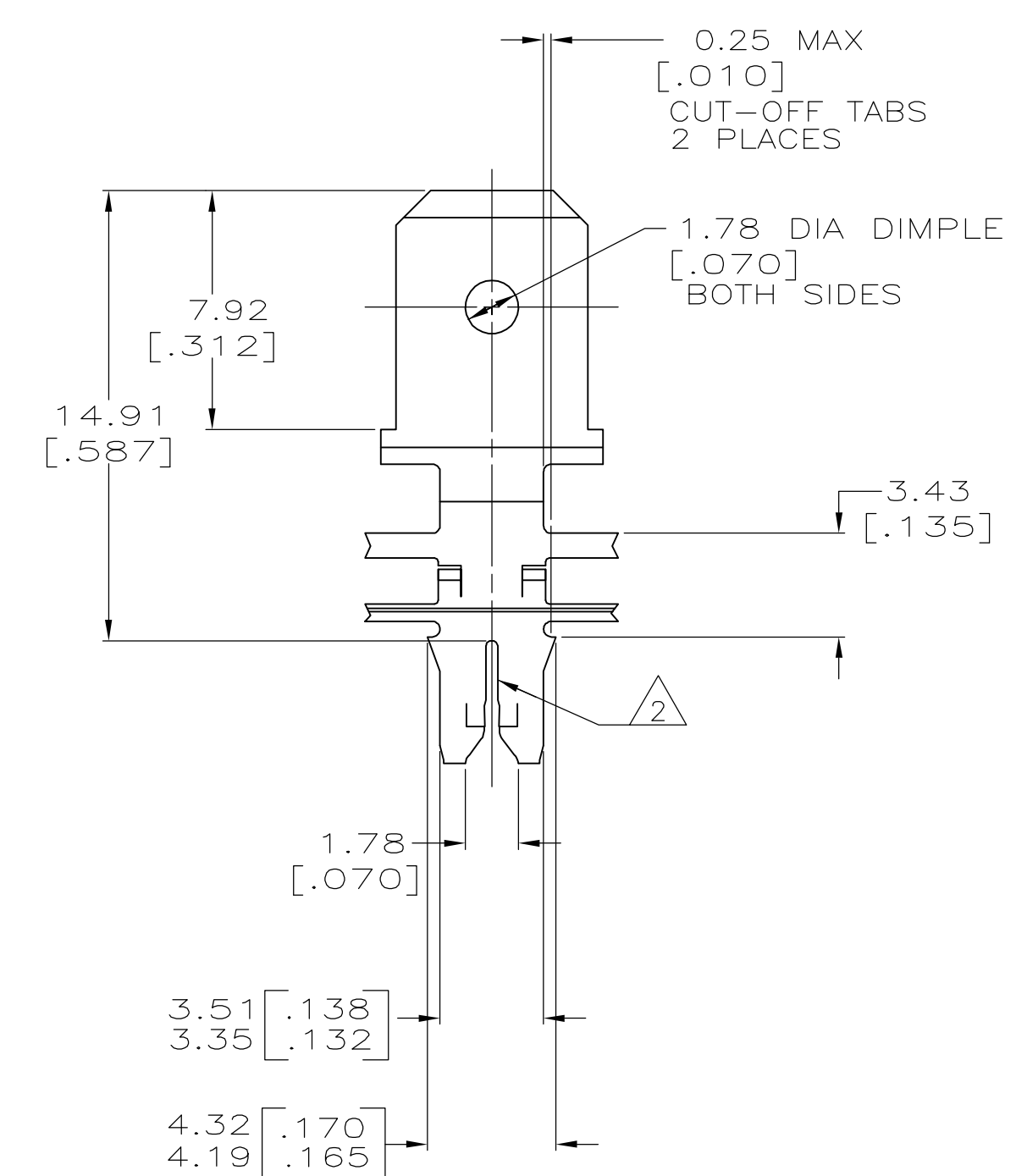

- 1 CONTINUOUS STRIP ON REELS WITH TERMINALS LOCATED ON 8.38±0.08 [.330±.003] CENTERS.
- 2 SLOT ACCEPTS 0.36-0.58mm [#27-#23] AWG COPPER MAGNET WIRE. 2 WIRES MAX OF THE SAME SIZE AND SHAPE PER SLOT.

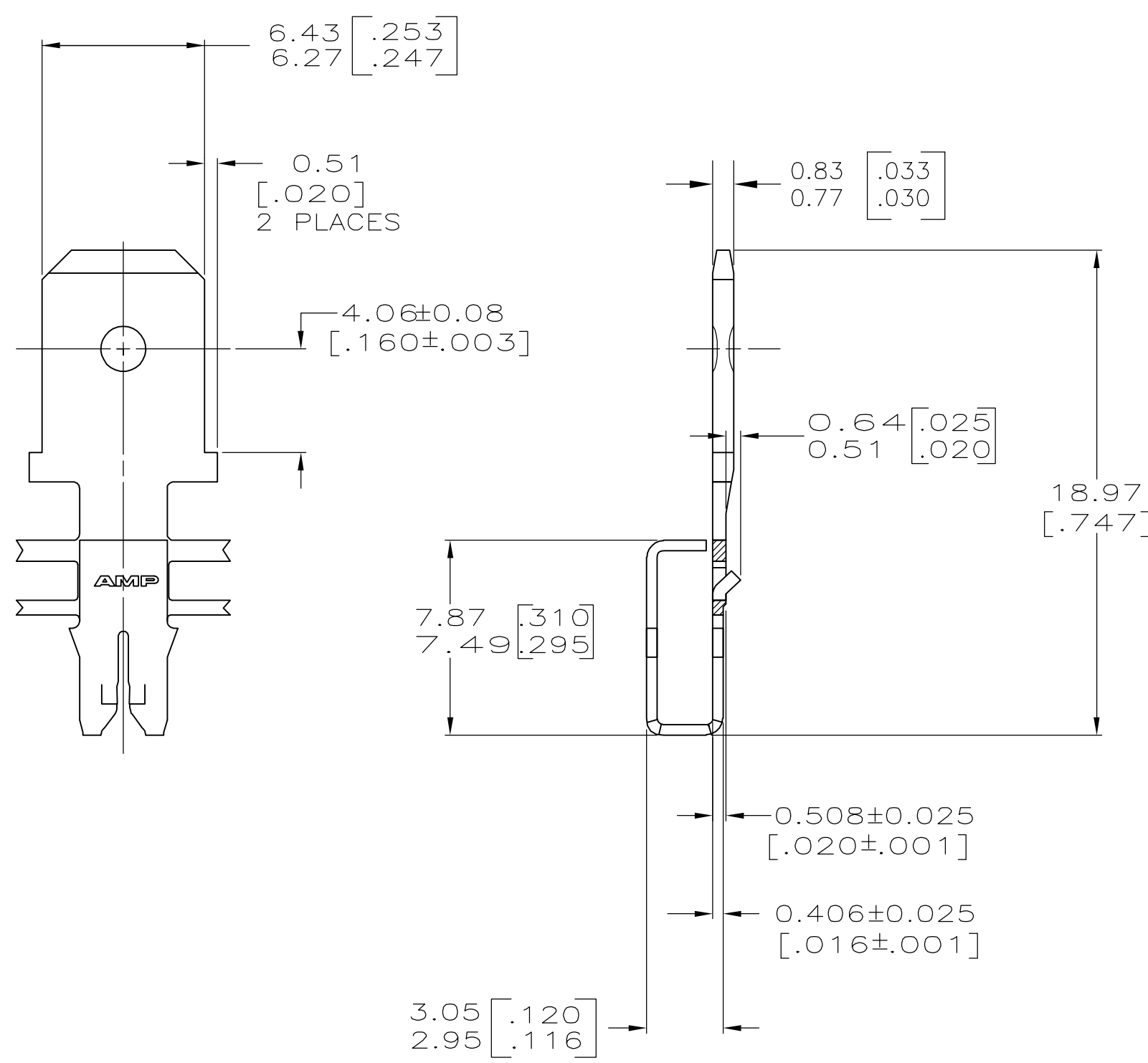

1217860-1
 PART NUMBER

THIS DRAWING IS A CONTROLLED DOCUMENT.		DWN MICHAEL S. FEHER 30JUL2002	Tyco Electronics Corporation Harrisburg, PA 17105-3608	
DIMENSIONS: mm [INCHES]		CHK KURT A. RANDOLPH 30JUL2002	NAME KURT A. RANDOLPH	
TOLERANCES UNLESS OTHERWISE SPECIFIED:		APVD KURT A. RANDOLPH 30JUL2002	PRODUCT SPEC 108-2012	
0 PLC ± -		APPLICATION SPEC 114-2067		
1 PLC ± -		SIZE A2		
2 PLC ± 0.25[.010]		CAGE CODE 00779		
3 PLC ± -		DRAWING NO 1217860		
4 PLC ± -		RESTRICTED TO -		
ANGLES ± - -		WEIGHT -		
MATERIAL 082 PRE-MILLED BRASS	FINISH 0.002032[.000080] MIN TIN PLATE	CUSTOMER DRAWING		
		SCALE 5:1	SHEET 1 of 1	REV B