

PFE1000FA Series Instruction Manual

BEFORE USING THE POWER SUPPLY UNIT (Common)

Be sure to read this instruction manual thoroughly before using this product.

Pay attention to all cautions and warnings before Using this product. Incorrect usage could lead to an electrical shock, damage to the unit or a fire hazard.

DANGER

- Never use this product in locations where flammable gas or ignitable substances are present.

INSTALLATION WARNING

- When installing, ensure that work is done in accordance with the instruction manual. When installation is improper, there is risk of electric shock and fire.
- Installation shall be done by service personnel with necessary and appropriate technical training and experience. There is a risk of electric shock and fire.
- Do not cover the product with cloth or paper etc. Do not place anything flammable around. This might cause damage, electric shock or fire.

WARNING on USE

- Do not touch this product or its internal components while circuit is operation, or shortly after shutdown. You may receive a burn.
- While this product is operating, keep your hands and face away from it as you may be injured by an unexpected situation.
- For products with no cover, do not touch them as there are high-voltage and high temperature parts inside. Touching them might cause injury such as electric shock or burn.
- There are cases where high voltage charge remains inside the product. Therefore, do not touch even if they are not in operation as you might get injured due to high voltage and high temperature. You might also get electric shock or burn.
- Do not make unauthorized changes to this product nor remove the cover as you might get an electric shock or might damage the product. We will not be held responsible after the product has been modified, changed or dis-assembled.
- Do not use this product under unusual condition such as emission of smoke or abnormal smell and sound etc. Please stop using it immediately and shut off the product. It might lead to fire and electric shock. In such cases, please contact us. Do not attempt repair by yourself, as it is dangerous for the user.
- Do not operate and store these products in environments where condensation occurs due to moisture and humidity. It might lead fire and electric shock.
- Do not drop or apply shock to this product. It might cause failure. Do not operate these products mechanical stress is applied.

CAUTION on MOUNTING

- Confirm connections to input/output terminals are correct as indicated in the instruction manual before switching on.
- Input voltage, Output current, Output power, Baseplate temperature, ambient temperature and ambient humidity should be kept within specifications, otherwise the product will be damaged.
- Input line, please use the wires as short and thick as possible.
- Do not use this product in special environment with strong electromagnetic field, corrosive gas or conductive substances and direct sunlight, or places where product is exposed to water or rain.
- Mount this product properly in accordance with the instruction manual, mounting direction and shall be properly be ventilated.
- Please shut down the input when connecting input and output of the product.
- When mounted in environments where there is conductive foreign matter, dust or liquid, there is possibility of product failure or malfunction. Such as install filter, please consider that a conductive foreign matter, dust and liquid do not invade inside the power supply.

CAUTION on USE

- Product individual notes are shown in the instruction manual. If there is any difference with common notes individual notes shall have priority.
- Before using this product, be sure to read the catalog and instruction manual. There is risk of electric shock or damage to the product or fire due to improper use.
- Input voltage, Output current, Output power, Baseplate temperature, ambient temperature and ambient humidity should be kept within specifications, otherwise the product will be damaged, or cause electric shock or fire.
- As our product is standard industrial use product that was manufactured by purpose that is used to an general electronics equipment etc., it is not products that to designed for High Safety uses (Uses extremely high reliability and safety are required, if reliability and safety has not been secured, with significant dangerousness for directly life or body) is expected. Please consider a fail safe (systems that was provided with protection circuit protective devices or systems that redundant circuit was mounted so that was not unstable in single failure) design enough.
- The equipment has been evaluated for use in a Pollution Degree 2 environment.
- When used in environments with strong electromagnetic field, there is possibility of product damage due to malfunction.
- When used in environments where there is conductive foreign matter, dust or liquid, there is possibility of product failure or malfunction.
- Provide countermeasure for prevention of lightning surge voltage as there is risk of damage due to abnormal voltage.
- Take care not to apply external abnormal voltage to the output. Especially, applying reverse voltage or overvoltage more than the rated voltage to the output might cause failure, electric shock or fire.
- Do not use this product in special environment with strong electromagnetic field, corrosive gas or conductive substances and direct sunlight, or places where product is exposed to water or rain.
- Never operate the product under overcurrent or short circuit conditions. Insulation failure, or other damages may occur.
- Protection must be provided for Service Engineers against indirect contact with the output terminals and/or to prevent tools being dropped across them. While working on this product, the AC input power must be switched off and the input, output, +BC, -BC and R terminal voltage should be safe level.
- The application circuits and their parameters are for reference only. Be sure to verify effectiveness of these circuits and their parameters before finalizing the circuit design.
- Excessive stress could cause damage. Therefore, please handle with care.
- Use a Fast-Blow external fuse to each module to ensure safe operation and compliance with the safety standards to which it is approved. The recommended input fuse rating within the instructions is as follows: 25A, 250V fast acting fuse. For externally mounted fuse do not use other fuses aside from our specified and recommended fuse.
- If the externally mounted fuse is blown, do not use the product even after replacing the fuse. There is risk of abnormality inside. Be sure to request repair to our company.
- The outputs less than 28V model has possibility that hazardous voltage may occur in output terminal depending on failure mode. The output of these products must be protected in the end use equipment to maintain SELV.
- 48V output model are considered non-SELV. End equipment manufacturers must provide protection against inadvertent contact by a service engineer.

Note

- Consider storage of the product at normal temperature and humidity avoiding direct exposure to sunlight at environment with minimal temperature and humidity changes. Storage of product at high temperature, high humidity and environments with severe changes in temperature and humidity might cause deterioration, and occurrence of condensation in the product.
- When disposing product, follow disposal laws of each municipality.
- If products are exported, please register the export license application etc. by the Government of Japan according to Foreign Exchange and Foreign Trade Control Law.
- This information in this document is subject to change without prior notice. Please refer to the latest version of the data sheet, etc., for the most up-to date specifications of the product.
- No part of this document may be copied or reproduced in any form without prior written consent TDK-Lambda.

1. Model name identification method

PFE 1000 FA - 12 / □

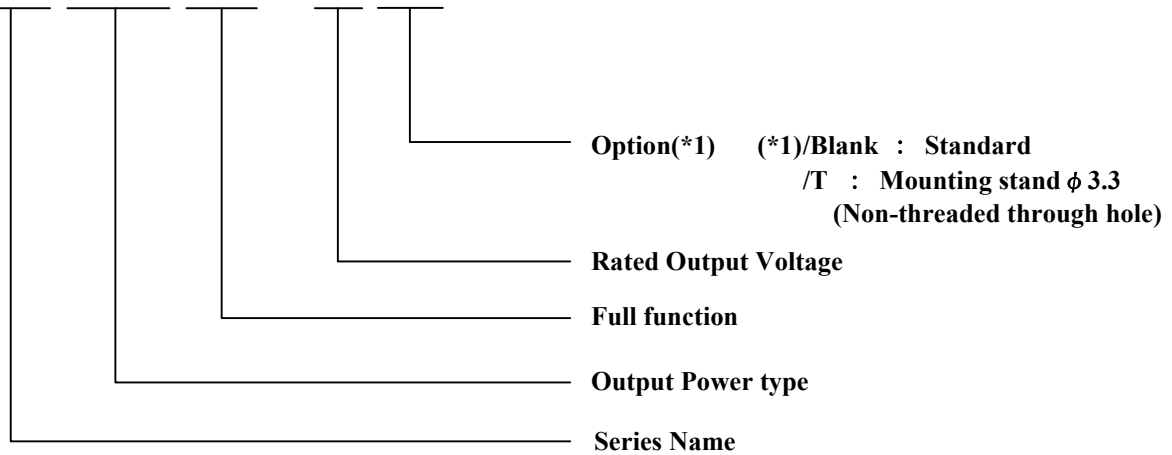

2. Terminal Explanation

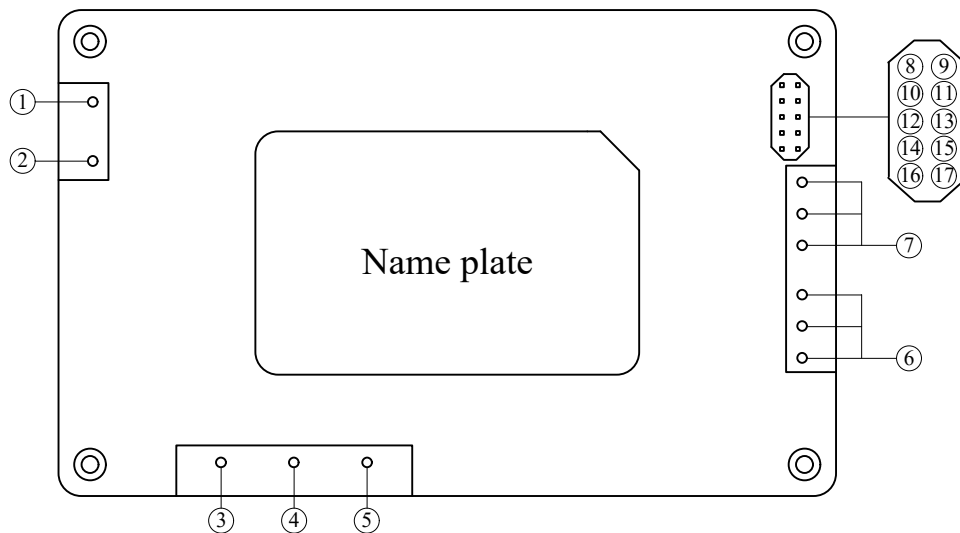

① AC(N)	: Input terminal neutral line	⑧ -S	: -Remote sensing terminal
② AC(L)	: Input terminal live line	⑨ +S	: +Remote sensing terminal
③ R	: External inrush current limiting resistor terminal	⑩ PC	: Output current balance terminal
④ +BC	: +Boosted voltage terminal	⑪ TRM	: Output voltage trimming terminal
⑤ -BC	: -Boosted voltage terminal	⑫ +ON/OFF	: +ON/OFF control terminal
⑥ +V	: +Output voltage	⑬ IOG	: Inverter operation good terminal
⑦ -V	: -Output voltage	⑭ -ON/OFF	: -ON/OFF control terminal
		⑮ ENA	: Power on signal terminal
		⑯ AUX	: Auxiliary power supply terminal for external circuits
		⑰ COM	: Common ground terminal

- Base-plate can be connected to FG through M3 mounting tapped holes.
- Consider contact resistance when connecting AC(L), AC(N), R, +BC, -BC, +V, -V.
- Note that +BC and -BC terminals are primary voltage with high voltage (385VDC). Do not connect load to these terminals. It might result in power module damage.

3. Block Diagram

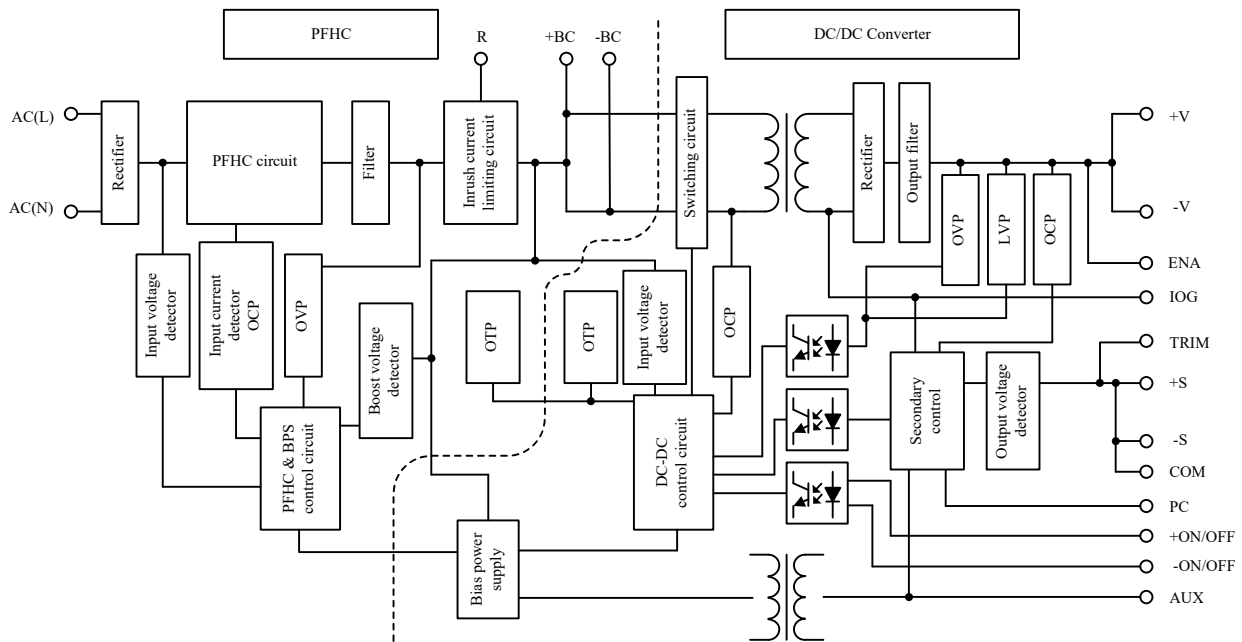

Switching Frequency

PFHC circuit(fixed) : 100kHz

DC/DC converter(fixed) : 230kHz (primary) , 460kHz (secondary)

4. Sequence Time Chart

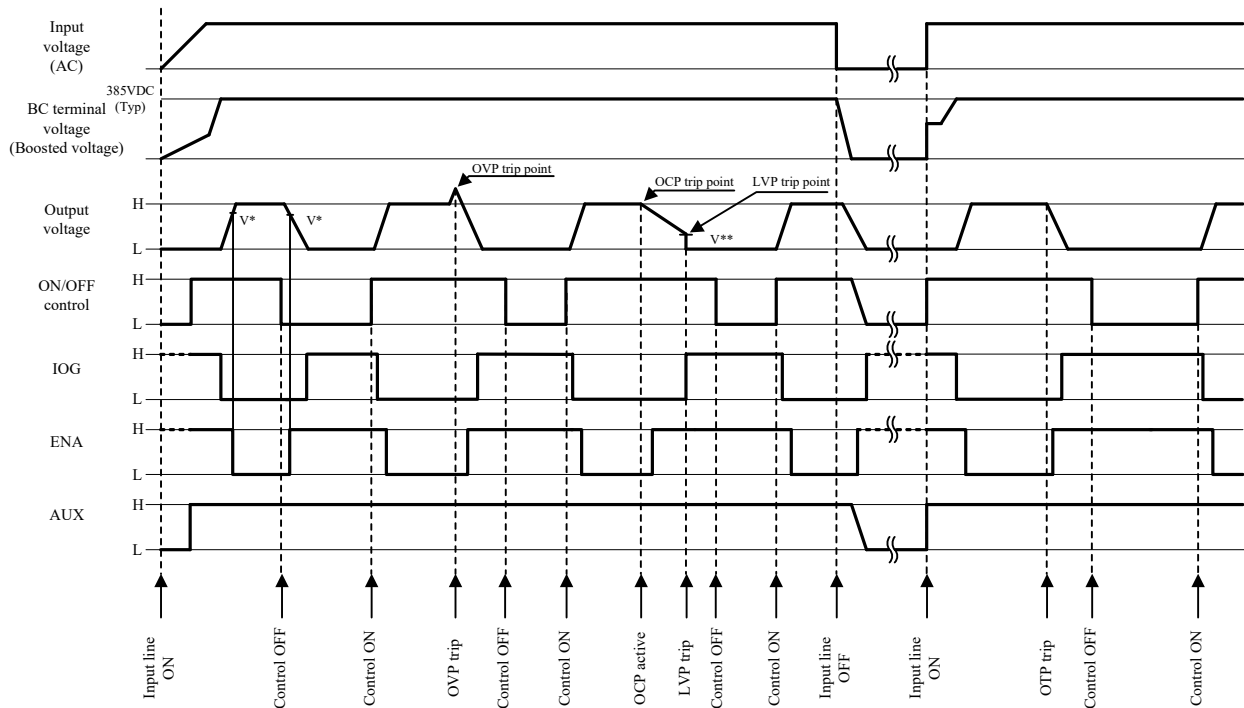

V* voltage level: Refer to Application Notes “6-9.Power ON Signal” section.

V** voltage level: Refer to Application Notes “6-5.Over Current Protection” section.

5. Terminal Connecting Method

In order to use the PFE1000FA Series, this module must be connected with external components according to Fig.5-1.

Pay attention to the each wiring. If it is connected to wrong terminal, the power supply will be damaged. PFE1000FA Series employs conduction cooling method. Use heat sink and fan to dissipate heat.

For selection of heat sink and heat sink dissipation method, refer to the Power Module Application Note.

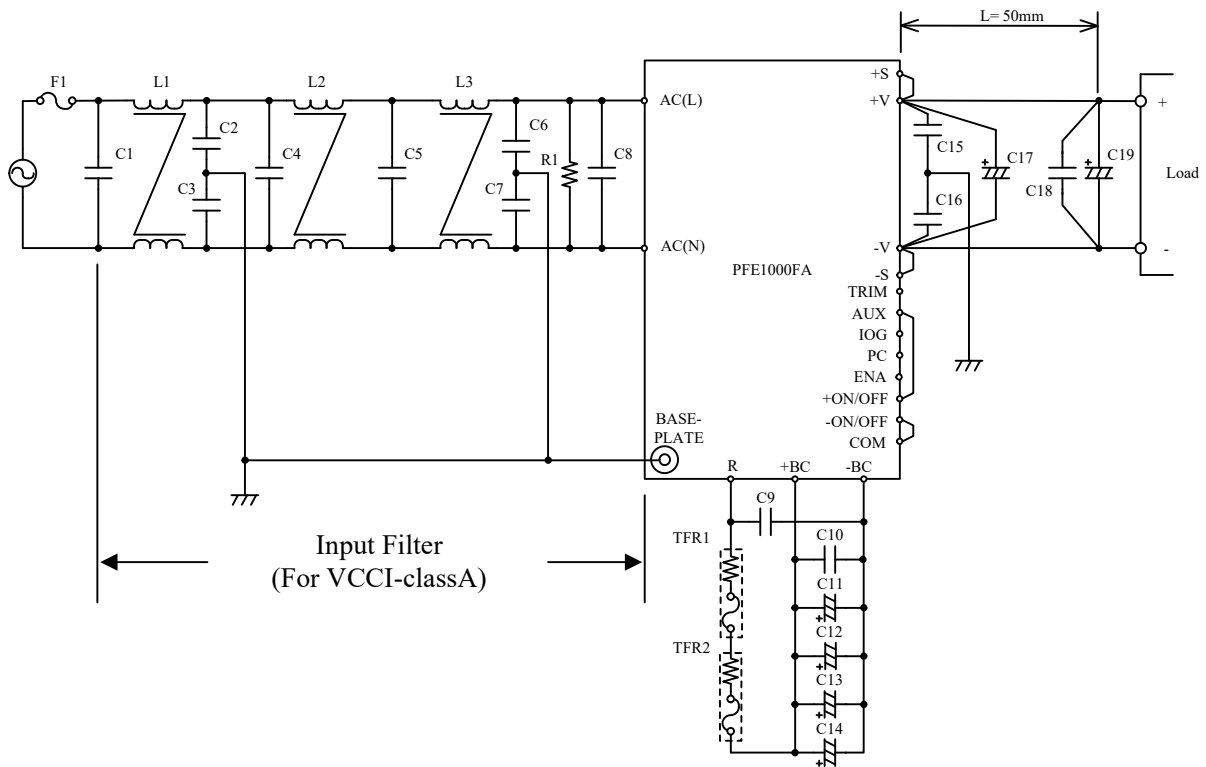

Fig.5-1 Basic connection

F1 : External Input Fuse

PFE1000FA Series has no internal fuse. Use external fuse to acquire each safety standard and to further improve safety.

PFE1000FA Series acquired safety standard certification using 25A, 250V, Fast-Blow external fuse.

Further, Fast-Blow type fuse must be used per one module. Also, in-rush surge current flows during line throw-in. Be sure to check I^2t rating of external switch and external fuse.

Recommended External Fuse : 25A, 250V

Note) Select fuse based on rated voltage, rated current and surge current capability.

(1) Voltage Ratings

100VAC line : AC125V

200VAC line : AC250V

(2) Current Ratings

Rated current is determined by the maximum input current based on operating conditions and can be calculated by the following formula.

$$I_{in} (\text{max}) = \frac{P_{out}}{V_{in} \times \eta \times PF} (\text{Arms}) \quad (\text{Formula 5-1})$$

$I_{in} (\text{max})$: Maximum Input Current

P_{out} : Maximum Output Power

V_{in} : Minimum Input Voltage

η : Efficiency

PF : Power Factor

For Efficiency and Power Factor values, refer to separate document "PFE1000FA Series Evaluation Data".

C1, C4, C5, C8 : 1uF (Film Capacitor)

Ripple current flows through this capacitor. When selecting capacitor, be sure to check the allowable maximum ripple current rating of this capacitor. Verify the actual ripple current flowing through this capacitor by doing actual measurement.

Connect C8 as close as possible toward the input terminals AC(N) and AC(L) of this power module.

Recommended Voltage Rating : 250VAC

L1, L2, L3 : 2mH

Add common mode choke coil as EMI/EMS countermeasure.

When using multiple modules, connect coil to each module.

Note) Depending on the input filter used, noise might increase or power module might malfunction due to filter resonance.

C2, C3 : 470pF (Ceramic Capacitor)

Add ceramic capacitor as EMI/EMS countermeasure. Be sure to consider leakage current of your equipment when adding this capacitor.

High withstand voltage are applied across this capacitor depending on the application. Select capacitor with high withstand voltage rating.

R1 : 470kΩ

Connect bleeder resistor across AC(L) and AC(N) terminals.

C6, C7 : 4700pF (Ceramic Capacitor)

Add ceramic capacitor as EMI/EMS countermeasure. Be sure to consider leakage current of your equipment when adding this capacitor.

High withstand voltage are applied across these capacitor during withstand voltage test depending on the application. Select capacitors with high withstand voltage rating.

Connect C6 as close as possible to AC(L) terminal, C7 as close as possible to AC(N) terminal.

C9, C10 : 1uF (Film Capacitor)

Ripple current flows through this capacitor. When selecting capacitor, be sure to check the allowable maximum ripple current rating of this capacitor.

Verify the actual ripple current flowing through this capacitor by doing actual measurement.

Connect C9 as close as possible to R terminal and -BC terminal, C10 as close as possible to +BC terminal and -BC terminal.

Recommended Voltage Rating : 450VDC

Note) Select capacitor with more than 3A (rms) rating.

C11, C12, C13, C14 : 390uF (Electrolytic Capacitor)

Refer to “Selection Method of External Bulk Capacitor for Boost Voltage” below.

Allowable external capacitance at nominal capacitance value is shown below.

Recommended Voltage Rating: 450VDC

Recommended Total Capacitance: 780uF - 2300uF

Note) 1. Do not connect capacitors with more than the above capacitance value as this would result into power module damage.

2. When using module below -20°C ambient temperature, AC ripple of boost voltage, output ripple voltage might be affected by ESR characteristics of the bulk capacitors. Therefore, be sure to verify characteristics by actual evaluation.

C15, C16 : 0.033uF

Connect ceramic or film capacitor as EMI/EMS countermeasure and to reduce spike noise.

High withstand voltage is applied across this capacitor during withstand voltage test depending on the application.

Connect C15 as close as possible to +V terminal, C16 as close as possible to -V terminal.

C17 : Refer to Table 5-1

To reduce output ripple noise voltage, connect electrolytic capacitors across +V and -V.
 Connect C17 as close as possible to the +V and -V output terminals of this power module.

Table 5-1 C17 : Recommended output external capacitance

Output voltage	C17
12V	25V 1000uF
28V	50V 470uF
48V	100V 220uF

C18 : 2.2uF (Ceramic Capacitor)

Connect chip ceramic capacitor at 50mm from the output terminals +V and -V of the power module to reduce output spike noise.

Also, note that output spike voltage may vary depending on the wiring pattern of the printed circuit board.

C19 : Refer to Table 5-2

Connect C19 at 50mm from the output terminals +V and -V of the power module to stabilize operation.

Note that the output ripple and line turn off characteristics of the power module might be affected by the ESR and ESL of the electrolytic capacitor.

Also, note that output ripple voltage may vary depending on the wiring pattern of the printed circuit board. Sudden change in output voltage due to sudden load change or sudden input voltage change can be reduced by increasing external output capacitance value.

Table 5-2 C19 : Recommended output external capacitance

Output voltage	C19
12V	25V 1000uF
28V	50V 470uF
48V	100V 220uF

Note) 1. Use low-impedance electrolytic capacitors with excellent temperature characteristics.

(Nihon Chemi-con LXY Series or equivalent)

(Nichicon PM Series or equivalent)

2. For module operation at ambient temperature -20°C or less, output ripple voltage might be affected by ESR characteristics of the electrolytic capacitors. Increase the capacitance values shown in Table 5-1 and 5-2 according to the table below.

Table 5-3 C17,C19 : Recommended output external capacitance(Ambient Temperature $\leq -20^{\circ}\text{C}$)

Output voltage	C17, C19
12V	25V 1000uF \times 2 parallel
28V	50V 470uF \times 2 parallel
48V	100V 220uF \times 2 parallel

3. Take note of the maximum allowable ripple current of the electrolytic capacitor used.

Especially, for sudden load current changes, verify actual ripple current and make sure that allowable maximum ripple current is not be exceeded.

For connection other than recommended capacitance, be sure to verify characteristics by actual evaluation.

● **Selection Method of External Bulk Capacitor for Boost Voltage**

Boost voltage bulk capacitor is determined by boost voltage ripple voltage, ripple current and hold-up time. Select capacitor value such that boost voltage ripple voltage does not exceed 15Vp-p.

Note) When ambient temperature is -20°C or less, ripple voltage of boost voltage might increase due to ESR Characteristics. Therefore, verify above characteristics by actual evaluation.

For output hold-up time, refer to separate document “PFE1000FA Series Evaluation Data” and use appropriate capacitor up to 2300uF maximum.

It is recommended that verification should be done through actual evaluation.

For allowable ripple current value, refer to Fig.5-2 and select a capacitor with higher ripple current rating.

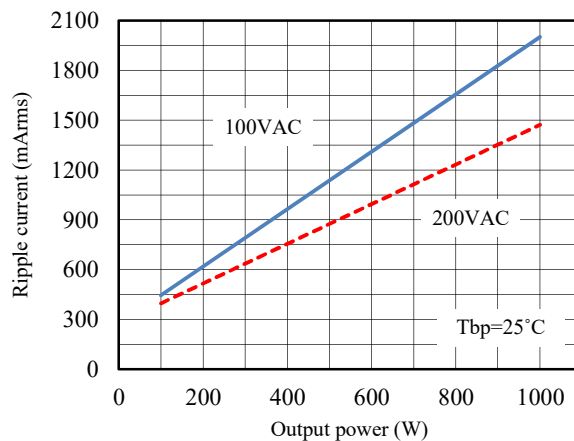

Fig.5-2 Allowable ripple current value

The recommended boost voltage bulk capacitance value range is 780uF-2300uF.

When using with reduced the bulk capacitance value, it is necessary to reduce output power as shown in Fig.5-3.

Fig.5-3 shows recommended value at 25°C base-plate temperature. Temperature variance might have some effect on the characteristics. Therefore, verify characteristics by performing actual evaluation. Refer to “Fig.7-1 Base-plate Measuring Point”.

Note that reducing the bulk capacitance affects output hold-up time, dynamic line response and dynamic load response characteristics. It is recommended that verification should be done through actual evaluation.

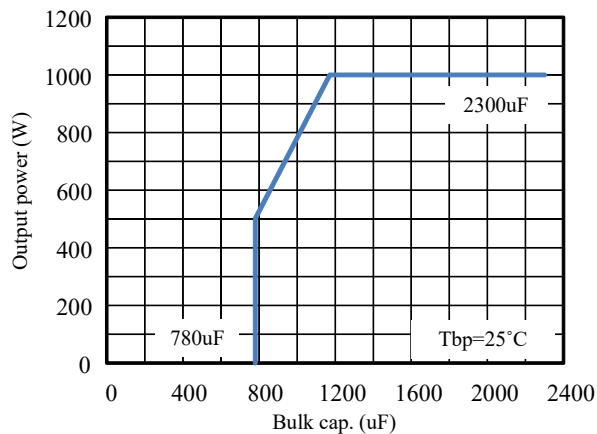

Fig.5-3 Output Power v.s. Boost Voltage Bulk Capacitance

TFR1,TFR2 : 10Ω - 30Ω (Total value : TFR1+TFR2 =10Ω - 30Ω)

By connecting thermal fuse resistor across R and +BC terminals as shown in Fig.5-1, in-rush current during line throw-in can be suppressed. Failures due to in-rush current such as melting of external fuse, welding of relay or switch connecting joints or shutdown of No-Fuse Breakers (NFB) can occur. Therefore, be sure to connect this external thermal fuse resistor of 10Ω or more. The allowable resistance value is limited by the external bulk capacitance value of shown in Fig.5-4. Note that power supply will not operate if this external resistor is not connected.

●Selection Method of External Resistor

(1)Calculating Resistance Value for TFR1+TFR2

Resistance can be calculated by the formula below.

$$R = \frac{V_{in}}{I_{rush}} (\Omega) \quad (\text{Formula 5-2})$$

R : Resistance Value for External TFR1+TFR2

V_{in} : Input Voltage converted to DC value = Input Voltage (rms) × √2

I_{rush} : Input surge current value

(2)Required Surge Current Rating

Sufficient surge current withstand capability is required for external TFR1+TFR2.

Required surge current rating can be selected by I²t. (Current squared multiplied by time)

$$I^2t = \frac{C_o \times V_{in}^2}{2 \times R} (A^2s) \quad (\text{Formula 5-3})$$

I²t : Current-squared multiplied by time

C_o : Boost Voltage Bulk Capacitance

V_{in} : Input Voltage converted to DC value = Input Voltage (rms) × √2

R : Resistance Value for External TFR1+TFR2

(3)TFR1+TFR2 limitation

TFR1+TFR2 is limited as shown in Fig.5-4.

Graph below shows resistor value at 25°C base-plate temperature. Input surge current might vary due to temperature. Therefore, verify characteristics by performing actual evaluation.

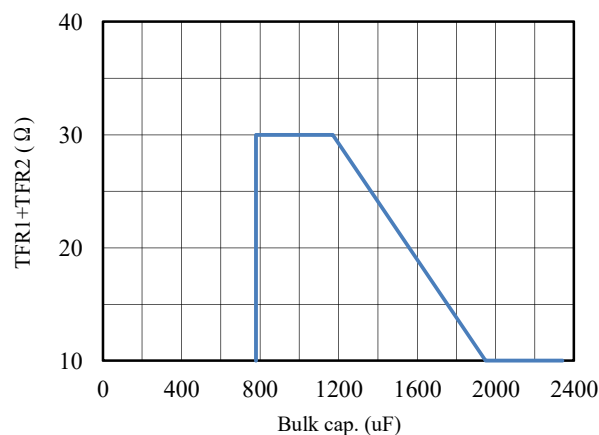

Fig.5-4 TFR1+TFR2 v.s. Boost Voltage Bulk Capacitance

6. Explanation of Functions and Precautions

6-1. Input Voltage

Input voltage range is single phase 85-265VAC(47-63Hz).

Take care not to apply input voltage which is out specified range nor should a DC input voltage be applied as this would result into power supply damage.

For cases where conformance to various safeties required, described as 100-240VAC (50-60Hz)

6-2. Output Voltage Range

Output voltage can be adjusted within the range below by connecting fixed and variable resistors.

However, take care not to exceed the output voltage range shown below because OVP function will activate.

Also, take care not to lower the output voltage range shown below because LVP function will activate.

Output Voltage Adjustment Range : +/-20% of the typical voltage rating

When increasing output voltage, reduce output current so as not to exceed maximum output power.

Even if the output voltage is adjusted using external circuit shown in Fig.6-1, remote sensing can be done.

For details on Remote Sensing function, refer to “6-7. Remote Sensing”.

●Output Voltage Adjustment using Fixed and Variable Resistors

External resistor (R2) and variable resistor (VR) values, as well as, circuit connection is shown below.

For this case, remote programming of the output voltage can be done through the remote programming resistor VR.

Be sure to connect the remote programming resistor between +S and +V terminals.

Table 6-1 External Resistor and Variable Resistor Value (For +/-20% Output Adjustment)

	12V	28V	48V
R2	18k Ω	18k Ω	18k Ω
VR	10k Ω	20k Ω	50k Ω

External Resistor (R2) : Tolerance +/-5% or less

Variable Resistor (VR) : Total Tolerance +/-20% or less End Resistance 1% or less

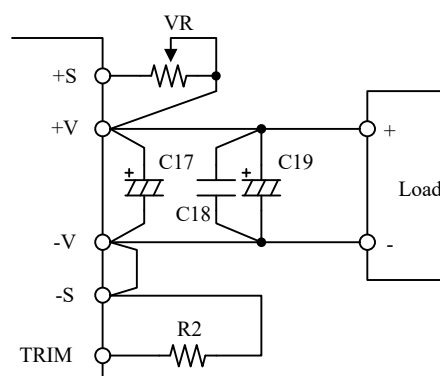

Fig.6-1 External resistor connection example

●Output Voltage Adjustment by applying external voltage

By applying external voltage at the TRIM terminal, output voltage can be adjusted within the same output voltage adjustment range as the output voltage adjustment by external resistor or variable resistor.

For this case, output voltage can be determined by the formula shown below.

$$\text{Output Voltage} = \text{TRIM Terminal Voltage} \times \text{Nominal Output Voltage}$$

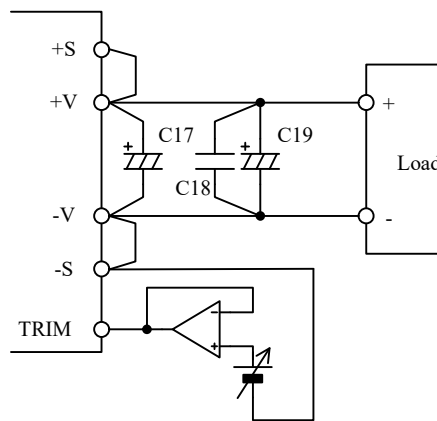

Fig.6-2 Output voltage adjustment by applying external voltage

For applications other than the above, refer to the TRIM circuit as shown in Fig.6-3 and determine external circuit and components values.

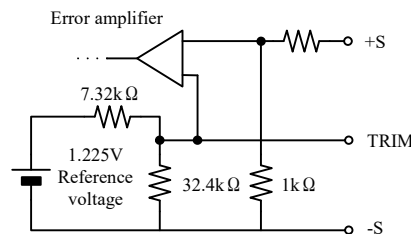

Fig.6-3 Internal TRIM circuit (for the reference)

6-3. Over Voltage Protection (OVP)

This module is equipped with OVP function. OVP function operates within 125%-145% of nominal output voltage. When OVP triggers, the output will be shut down. When the OVP function activates, first cut off input line and verify that boost voltage has dropped down to 20V or less. Then, recover output by recycling input line. In other method, reset to ON/OFF control.

OVP value is fixed and cannot be set externally.

Pay attention not to apply higher voltage externally to the output terminal to avoid power supply damage.

6-4. Over Current Protection (OCP)

This module is equipped with OCP function. Constant current limiting with delay shutdown for PFE1000FA Series. Output will be shutdown when output about under 70% by short circuit or overload condition that continue about 0.5s. When the shutdown function activates, first cut off input line and verify that boost voltage has dropped down to 20V or less. Then, recover output by recycling input line. In other method, reset to ON/OFF control.

OCP value is fixed and cannot be adjusted externally.

Note that continuous short circuit or overload condition, might result in power module damage.

6-5. Over Temperature Protection (OTP)

This module is equipped with OTP function. This function will activate and shutdown the output when ambient temperature or internal temperature abnormally rises. OTP activates at following base-plate temperature.

Base-plate temperature(Tbp) : 105°C - 130°C

When OTP function operates, output can be recovered by cooling down the base-plate sufficiently and letting the Boost voltage drop down to 20V or less before recycling the input line. In other method, reset to ON/OFF control.

6-6. Remote Sensing (+S, -S Terminals)

This module has remote sensing terminals to compensate for voltage line drop from the output terminals to the output load. When remote sensing is not required, (local sensing) short +S to +V and -S to -V terminals respectively.

Note that line drop (voltage drop due to wiring) compensation voltage range must be such that the output voltage is within the output voltage adjustment range and that the voltage between -V and -S must be within 2V.

Consider power loss due to line drop and use power supply within the maximum allowable output power. Before using, do adequate prior evaluation such that module does not receive any effect of noise by using a parallel pattern, etc. for remote sensing line.

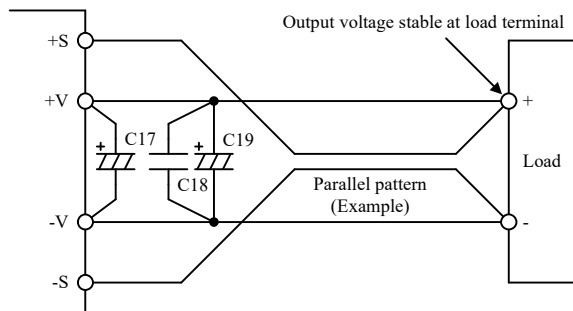

Fig.6-4 Remote sensing is used

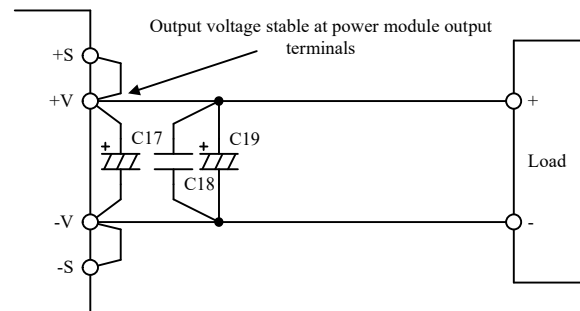

Fig.6-5 Remote sensing is not used (local sensing)

6-7. ON/OFF Control (+ON/OFF, -ON/OFF Terminal)

This module is equipped with ON/OFF control function.

It is possible to ON/OFF control of output voltage at input applied state by using this function.

The ON/OFF control circuit is isolated from input circuit of the power supply by photo-coupler.

Fig.6-6 and Fig.6-7 is connection example of ON/OFF control.

When the ON/OFF control is not used, short +ON/OFF to AUX and -ON/OFF to COM terminals respectively.

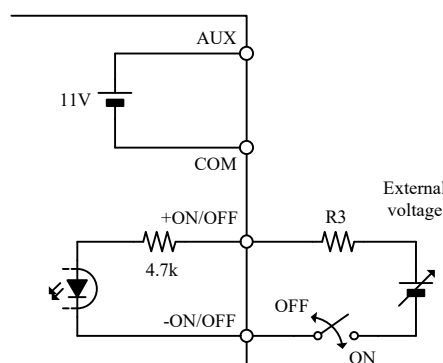

Fig.6-6 ON/OFF control connection example 1 (ON/OFF control by external voltage)

Select the external voltage and external resistance, as the ON/OFF terminals current is shown below.

Table 6-2 Recommended ON/OFF terminal current

ON/OFF terminal current	Output Voltage
2.5mA (± 0.5 mA)	ON
Less than 0.15mA	OFF

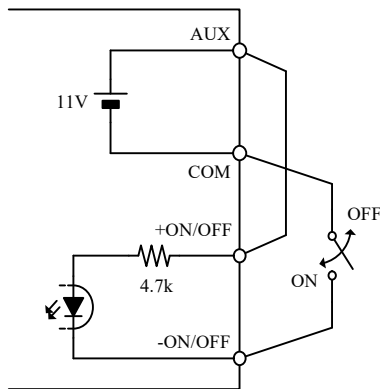

Fig.6-7 ON/OFF control connection example 2
 (ON/OFF control by built-in AUX)

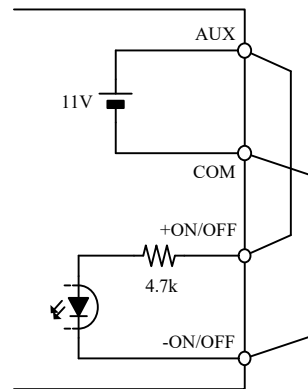

Fig.6-8 ON/OFF control connection example 3
 (ON/OFF control is not used)

6-8. Power ON Signal (ENA Terminal)

This signal is located at the secondary side (output side) and is an open drain output.

Maximum sink current : 10mA
 Maximum applied voltage : 75V

Ground for the ENA terminal is the -V terminal. When output voltage goes over a specified voltage level at start up, Power ON signal is “Low level”. Output voltage threshold level is as follows.

Table 6-3 Output voltage in case an ENA signal changes

ENA signal	12V	28V	48V
High → Low	6V(TYP)	15V(TYP)	28V(TYP)

6-9. I.O.G Signal (IOG terminal)

Normal or abnormal operation of the power module can be monitored by using the IOG terminal. Output of this signal monitor is located at secondary side (output side) and is an open collector output. This signal is LOW when inverter is normally operating and HIGH when inverter stops or when inverter is operating abnormally.

Maximum sink current : 5mA
 Maximum applied voltage : 35V

Ground for the IOG terminal is the COM terminal.

Also note that IOG becomes unstable for following conditions:

- Operation of Over Current Protection (OCP)
- Light load conditions
- Dynamic load operation

6-10. Auxiliary Power Supply for External Circuits (AUX Terminal)

For AUX terminal, output voltage value is within 10~14VDC range, maximum output current is 20mA. Ground for the AUX terminal is COM terminal.

Avoid short circuit of AUX terminal with other terminals as this would lead to power module damage.

6-11. Parallel Operation (PC Terminal)

By connecting the PC terminal of each power module, output current can be equally drawn from each module. A maximum of 6 units of the same model can be connected.

However, maximum output current is derated by parallel operation units as shown in Table 6-4. Note that usage of power module at out-of-rated condition might result in power module temperature abnormal rise or damage.

Table 6-4 Condition for parallel operation

Parallel units	Maximum output current
~3 units	90% of nominal output current
4~6 units	85% of nominal output current

Set the accuracy of the output voltage within +/-2% when adjust the output voltage for parallel operation. When adjust the output voltage by applying external voltage at the TRIM terminal, insert a about 10k ohm resistor between TRIM terminal and external source.

Moreover, external circuits are necessary for TRIM terminal at each individual module.

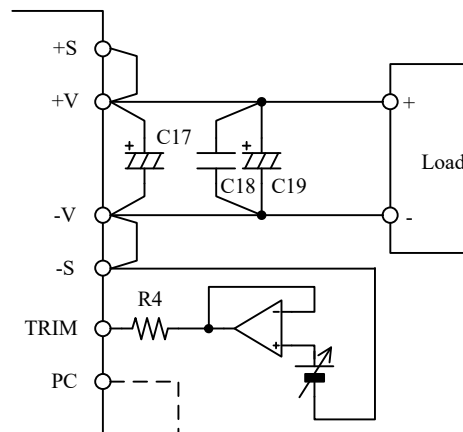

Fig.6-9 Output voltage adjustment by applying external voltage (for parallel operation)

At parallel operation, +BC, -BC and R terminals must not be connected in parallel with other modules. It might result in power module damage.

Refer to “Parallel Operation” of the Power Module Application Notes for details.

6-12. Series Operation

Series operation is possible for PFE1000FA Series. Connections shown in Fig.6-10 and Fig.6-11 are possible.

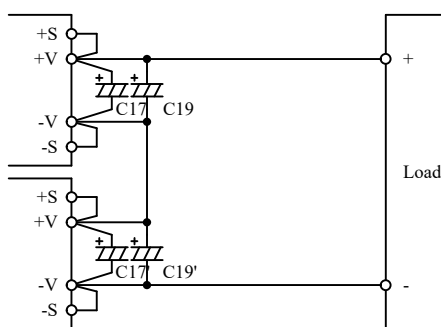

Fig.6-10 Series operation for high output voltage applications

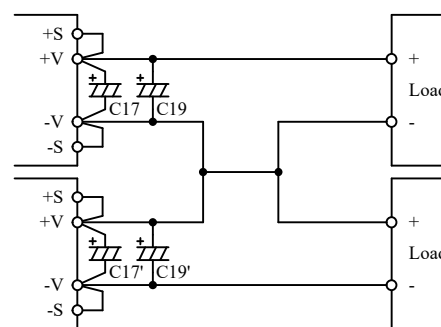

Fig.6-11 Series operation ±output series applications

6-13. Maximum Ripple and Noise

This value is measured according to the description below in accordance with JEITA RC-9131B.

In the basic connection shown in Fig.5-1, additional connection shown in Fig.6-12 is done for measurement. Capacitor (Ceramic capacitor(C18) : 2.2 μ F and Electrolytic capacitor(C19) : refer to Table 5-2) must be connected within 50mm from the output terminals. Then, connect coaxial cable with JEITA attachment across the ceramic capacitor electrodes. Use 100MHz bandwidth oscilloscope or equivalent.

Also, note that output ripple voltage and output spike noise may vary depending on the wiring pattern of the printed circuit board.

In general, output ripple voltage and output spike noise can be reduced by increasing external capacitor value.

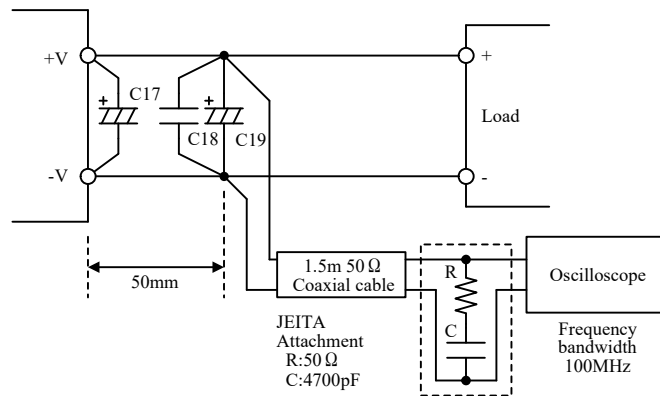

Fig.6-12 Output ripple voltage (including spike noise) measurement method

6-14. Isolation Resistance

Isolation resistance between Output - Base-plate is more than 100M Ω at 500VDC. For safety operation, voltage setting of DC isolation tester must be done before the test. Ensure that the unit is fully discharged after the test.

Output - Base-plate : 100M Ω or more at 500VDC

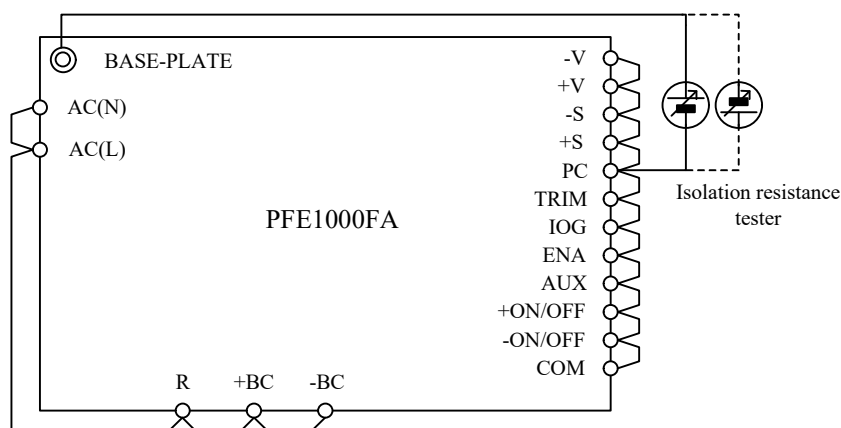

Fig.6-13 Isolation resistance test method

6-15. Withstand Voltage Test

This series is designed to withstand 2.5kVAC between input and base-plate, 3.0kVAC between input and output and 500VDC between output and base-plate each for 1 minute. When testing withstand voltage, set current limit of withstand voltage test equipment at 20mA.

Be sure to apply DC voltage between output - base-plate. Avoid applying AC voltage during this test because this will damage the power supply.

The applied voltage must be gradually increased from zero to testing value and then gradually decreased for shut down. When timer is used, the power supply may be damaged by high impulse voltage at timer switch on and off.

Connect each terminals according to the circuit diagram shown below.

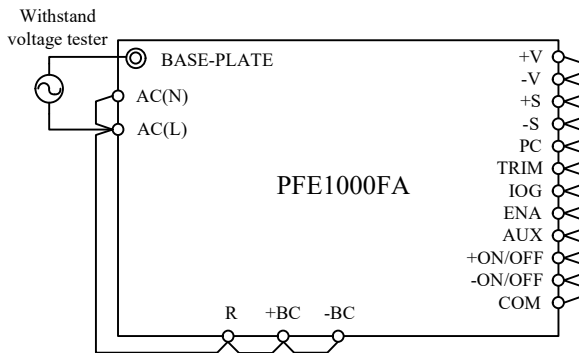

2.5kVAC 1 minute (20mA)

Fig.6-14 Input to base-plate withstand voltage test method

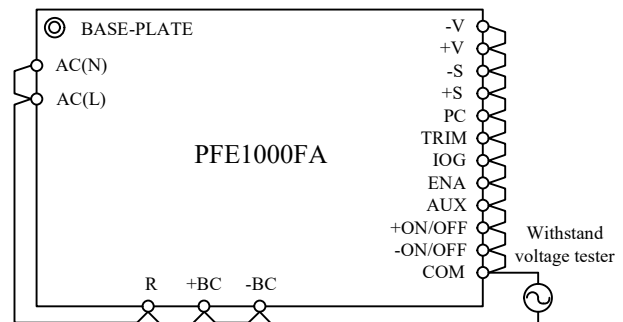

3kVAC 1 minute (20mA)

Fig.6-15 Input to output withstand voltage test method

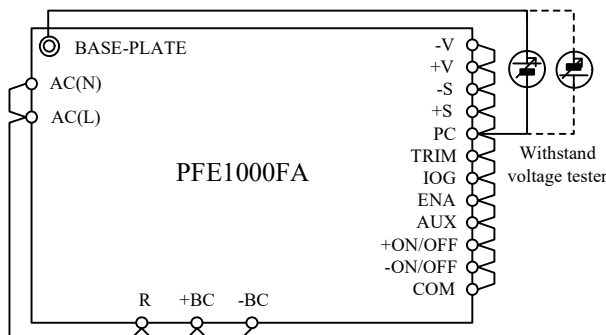

500VDC 1 minute

Fig.6-16 Output to base-plate withstand voltage test method

Withstand Voltage Testing with External Application

The above Withstand Voltage Testing specification applies only to power module as stand-alone unit. Please take note of the following points when Withstand Voltage Testing is performed with attached external application.

For connections shown in Fig.5-1, when injecting 3kVAC between Input - Output, Voltage Divider Ratio between Input - Base-plate and Output - Base-plate will be affected by capacitance value ratio connected between the Input - Base-plate and Output - Base-plate.

When selecting external capacitor at the Input - Base-plate and Output - Base-plate, take care of the capacitance value and voltage rating.

Capacitor of Input - Base-plate : (C2,C3,C6,C7)

Capacitor of Output - Base-plate : (C15,C16)

7. Mounting Method

7-1. Mounting Method

These products can be used in any orientation but be sure to consider enough airflow to avoid heat accumulation around the power supply. Consider surrounding components layout and set the PCB mounting direction such that air can flow through the heat sink by forced or convection cooling. Refer to the power module application note "Power module mounting method" for mounting method on PWB. This product can operate at actual mounting condition when base-plate temperature and ambient temperature are maintained at or below the following temperature.

PFE1000FA-12	: 100°C
PFE1000FA-28,48	: 85°C (85VAC ≤ Vin < 170VAC)
	: 100°C (170VAC ≤ Vin ≤ 265VAC)

Temperature at worst case operating condition at the measuring point shown in Fig.7-1 and Fig.7-2. For Thermal Design details, refer to Application Notes "Thermal Design" section.

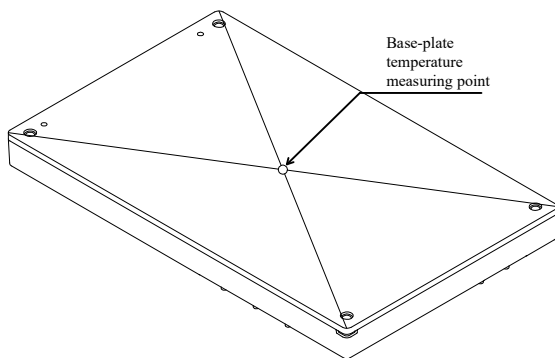

Fig.7-1 Base-plate temperature measuring point

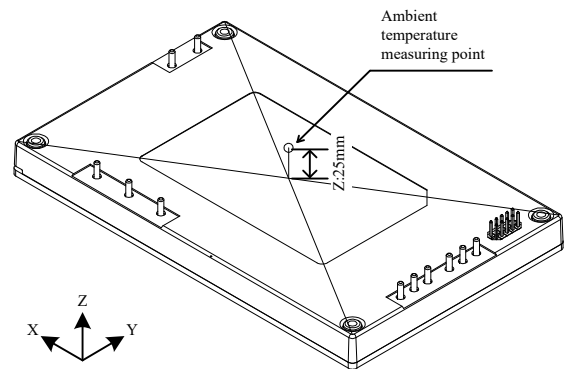

Fig.7-2 Ambient temperature measuring point

7-2. Output Derating

Operating temperature range is limited according to Fig.7-3.

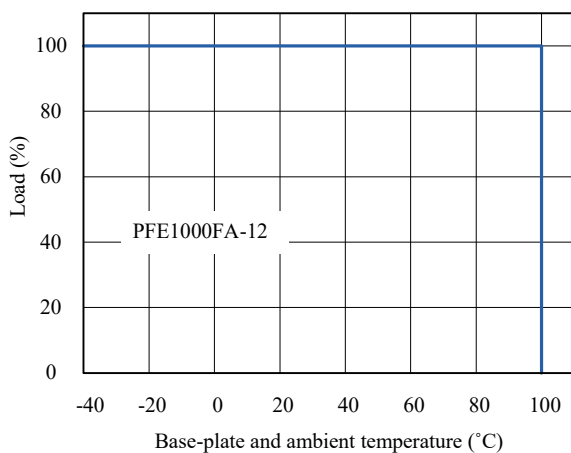

Fig.7-3-(1) PFE1000FA-12 derating curve

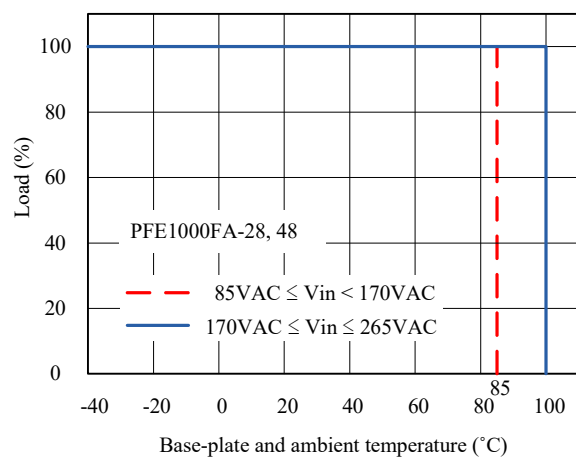

Fig.7-3-(2) PFE1000FA-28, 48 derating curve

To further improve the reliability, it is recommended to use this power supply with base-plate and ambient temperature derating.

7-3. Recommended Soldering Condition

Recommended soldering temperature is as follows.

Soldering Dip : 260°C, within 10 seconds

Preheat : 130°C, within 60 seconds

7-4. Recommended washing Condition.

After soldering, following washing condition is recommended.

For other washing conditions, consult our Customer Support Group.

(1) Recommended washing solution

- IPA (Isopropyl Alcohol)

(2) Washing method

In order to avoid penetration inside the power module, washing should be done with brush.

Then, dry up thoroughly after washing.

8. Before Concluding Power Module Damage

Verify following items before concluding power module damage.

(1) No output voltage

- Is specified input voltage applied?
- During output voltage adjustment, is the fixed resistor or variable resistor setting correct?
- Is there no abnormality with the output load?
- Is the actual base-plate temperature within the specified operating temperature of this module?
- Are the ON/OFF control terminals (+ON/OFF, -ON/OFF) correctly connected?

(2) Output voltage is high

- Are the remote sensing terminals (+S, -S) correctly connected?
- Is the measurement done at the sensing points?
- During output voltage adjustment, is the fixed resistor or variable resistor setting correct?

(3) Output voltage is low

- Is specified input voltage applied?
- Are the remote sensing terminals (+S, -S) correctly connected?
- Is the measurement done at the sensing points?
- During output voltage adjustment, is the fixed resistor or variable resistor setting correct?
- Is there no abnormality with the output load?

(4) Load regulation or line regulation is large

- Is specified input voltage applied?
- Are the input or output terminals firmly connected?
- Is the measurement done at the sensing points?
- Are the input and output wires too thin?

(5) Large output ripple

- Is the measurement done according to methods described in the Instruction Manual or is it an equivalent method?

9. Warranty Period

Warranty period is 5 years.

For damages occurring at normal operation within this warranty period, exchange is free of charge.

Following cases are not covered by warranty

- (1) Improper usage like dropping products, applying shock and defects from operation exceeding specification of the unit.
- (2) Defects resulting from natural disaster (fire, flood etc.)
- (3) Unauthorized modifications or repair by the buyers' defects not cause by our company.

10. CE MARKING / UKCA MARKING

CE MARKING

CE Marking, when applied to a product or packing material for a product covered by this handbook, indicates compliance with the Low Voltage Directive and RoHS Directive.

UKCA MARKING

UKCA Marking, when applied to a product or packing material for a product covered by this handbook, indicates compliance with the Electrical Equipment (Safety) Regulations and Restriction of the Use of Certain Hazardous Substances in Electrical & Electronic Equipment Regulations.