

PART NUMBER		REV	FIRST USED	POWER UNIT	FEED TYPE
1855064-1		A	122500-1	LEADMAKER & BENCH MODEL G	POST FEED
1855064-2		A	565435-5	BENCH MODEL K	POST FEED
7-1855064-7		A	-	SPARE PARTS	-

- △ RECOMMENDED SPARE PARTS
- △ GREASE LIGHTLY
- △ GUARD MUST BE IN PLACE WHEN OPERATING APPLICATOR IN A BENCH MACHINE

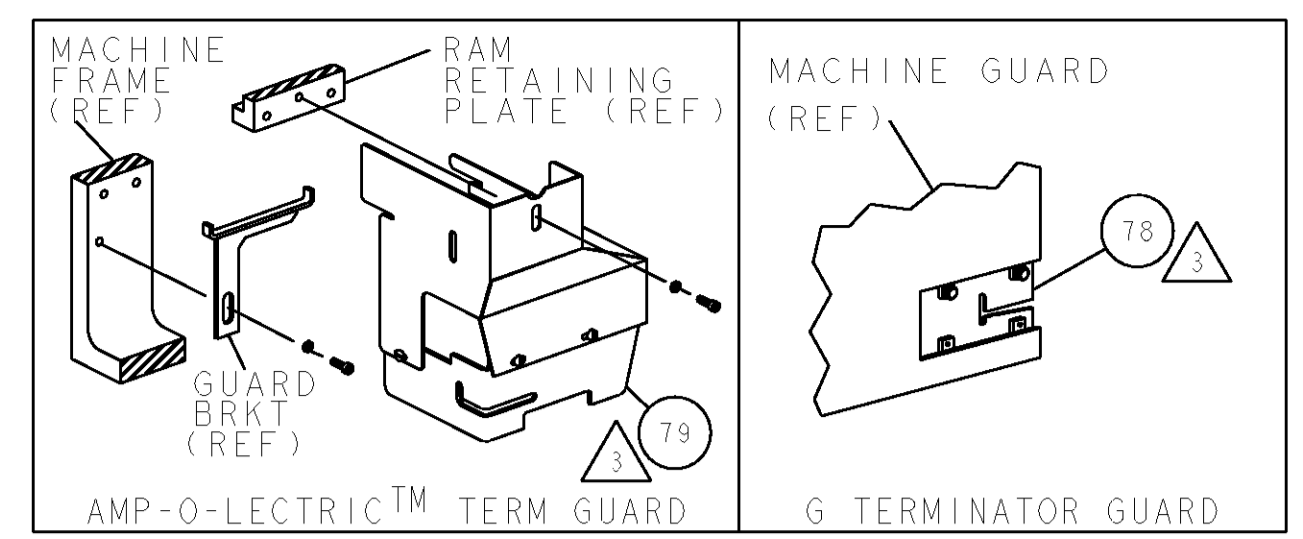

TERMINAL NAME: RECEPTACLE, FASTON, .250 SERIES					
60295	-	AMP TERMINAL - AMP CRIMP SPECS			
280095	-				
	REF SETTING	CRIMP HEIGHT	WIRE SIZE		
-	A9	.048±.002[1.22±0.05mm]	18 AWG		
-	B6	.044±.002[1.12±0.05mm]	20 AWG		
-	C1	.042±.002[1.07±0.05mm]	22 AWG		
-	-	-	-		
	CRIMP	SIZE	TYPE	RANGE	
-	-	WIRE	.090 [2.29mm]	F	22-18 AWG
-	-	INSUL	.140 [3.56mm]	O	∅.085-.120
WIRE STRIP LENGTH	TERM APPL SPEC	FEED	APPL INSTRUCTIONS	SET UP GAGE	
.186 -.201	114-2025	.840	408-8039	458638-1	

LOC	DIST	REVISIONS			
A	66	P LTR	DESCRIPTION	DATE	DWN APVD
		A	RELEASED	18APR2006	ROW GB

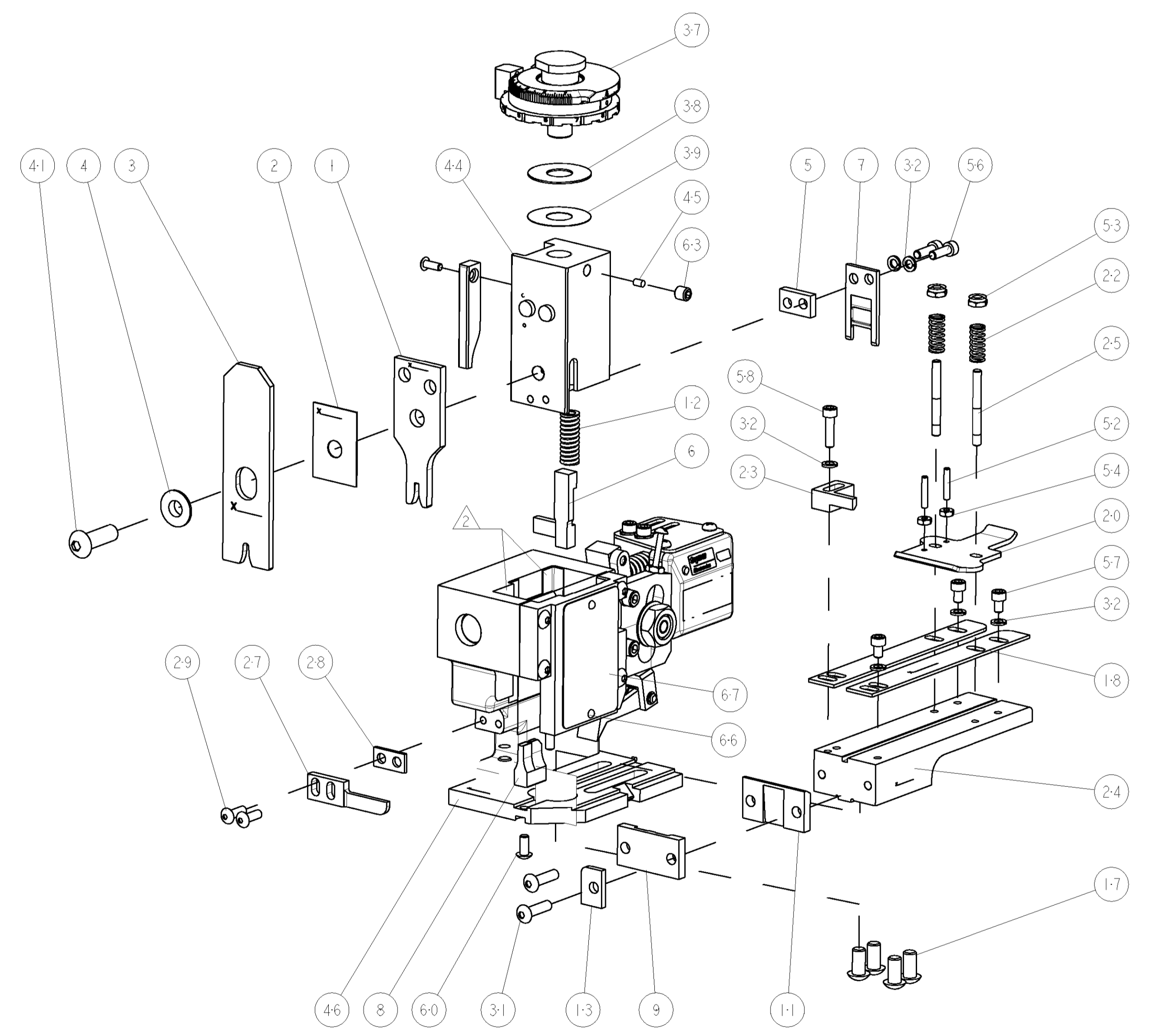

△	-	REF	-	..	455745-1	GUARD WINDOW	79
△	-	REF	-	..	679532-1	INSERT, GUARD	78
-	1	1	-	-	217238-1	GENERAL INSTRUCTION PKG	72
-	1	1	-	-	4088039	EF APPL INST 408-8039	71
-	1	1	-	-	461264-5	PLATE, IDENTIFICATION	67
-	2	2	-	-	21017-2	SCREW, DRIVE	66
-	1	1	-	-	21009-2	SCR, SET, SELF LOCKING 1/4-20 X .250	63
-	1	1	-	-	22733-8	SCR, BHSC, SELF-LOCKING, 8-32 X .375	60
-	2	2	-	-	2-21000-8	SCR, SKT HD CAP 8-32 X .625	58
-	3	3	-	-	2-21000-5	SCR, SKT HD CAP 8-32 X .250	57
-	2	2	-	-	2-21000-7	SCR, SKT HD CAP 8-32 X .500	56
-	2	2	-	-	21018-4	NUT, HEX, REG 4-40	54
-	2	2	-	-	21022-2	NUT, LOCK, HEX, TORQUE, 8-32	53
-	2	2	-	-	2-21006-6	SCR, SET, CUP POINT 4-40 X .625	52
-	1	1	-	-	1-21002-7	SCR, BTN SKT HD CAP 6-32 X .375	49
-	1	-	-	..	690501-3	CAM, POST FEED, 1 1/8	48
-	-	1	-	-	690501-4	CAM, POST-FEED 1 5/8	47
-	1	1	-	-	458980-1	SUB ASSY, APPLICATOR FRAME	46
-	1	1	-	-	690191-1	PLUG, NYLON	45
-	1	1	-	-	455674-1	RAM	44
-	1	1	-	-	7-21002-9	SCR, BTN SKT HD CAP 5/16-24 X 1.00	41
-	1	1	-	-	690125-1	SHIM SUB-ASSY	39
-	1	1	-	-	469367-8	SHIM	38
-	1	1	-	-	879103-3	FINE ADJUST HEAD SUBASSY	37
-	7	7	-	-	21024-4	WASHER, SPRG LOCK, REG NO 8	32
-	2	2	-	-	2-21002-9	SCR, BTN SKT HD CAP 10-32 X .750	31
-	2	2	-	-	2-21002-2	SCR, BTN SKT HD CAP 8-32 X .500	29
-	1	1	-	-	3-690451-2	SPACER, STRIPPER	28
-	1	1	-	-	240639-1	STRIPPER (MACHINING)	27
-	2	2	-	-	22354-8	STUD, THREADED	25
-	1	1	-	-	458803-2	PLATE, STRIP GUIDE, SLOTTED	24
-	1	1	-	-	240825-3	PLATE, STRIP HOLD DOWN	23
-	2	2	-	-	4-22281-1	SPRING, DRAG	22
-	1	1	-	-	454177-1	DRAG	20
-	2	2	-	-	454204-1	GUIDE, LOWER STRIP	18
-	4	4	-	-	3-21002-3	SCR, BTN SKT HD CAP 1/4-20 X .500	17
-	1	1	-	-	690481-7	SPACER, HOLD DOWN	13
-	1	1	-	-	23846-1	SPRING, DIE	12
-	1	1	-	-	240833-2	PLATE, REAR SHEAR	11
-	1	1	-	-	690482-3	PLATE, FRONT SHEAR	9
△	1	1	-	-	6-240693-2	ANVIL, COMBINATION	8
△	1	1	-	-	690474-3	BLADE, SLUG	7
△	1	1	-	-	2-455892-7	HOLD DOWN, TERMINAL	6
-	1	1	-	-	2-240641-0	SPACER	5
-	1	1	-	-	238009-1	BLOCK, FL CRIMPER SPACER	4
△	1	1	-	-	3-456135-8	CRIMPER, INSULATION O PREMIUM	3
△	1	1	-	-	455888-4	SPACER, CRIMPER	2
△	1	1	-	-	1-456406-2	CRIMPER, WIRE PREMIUM	1

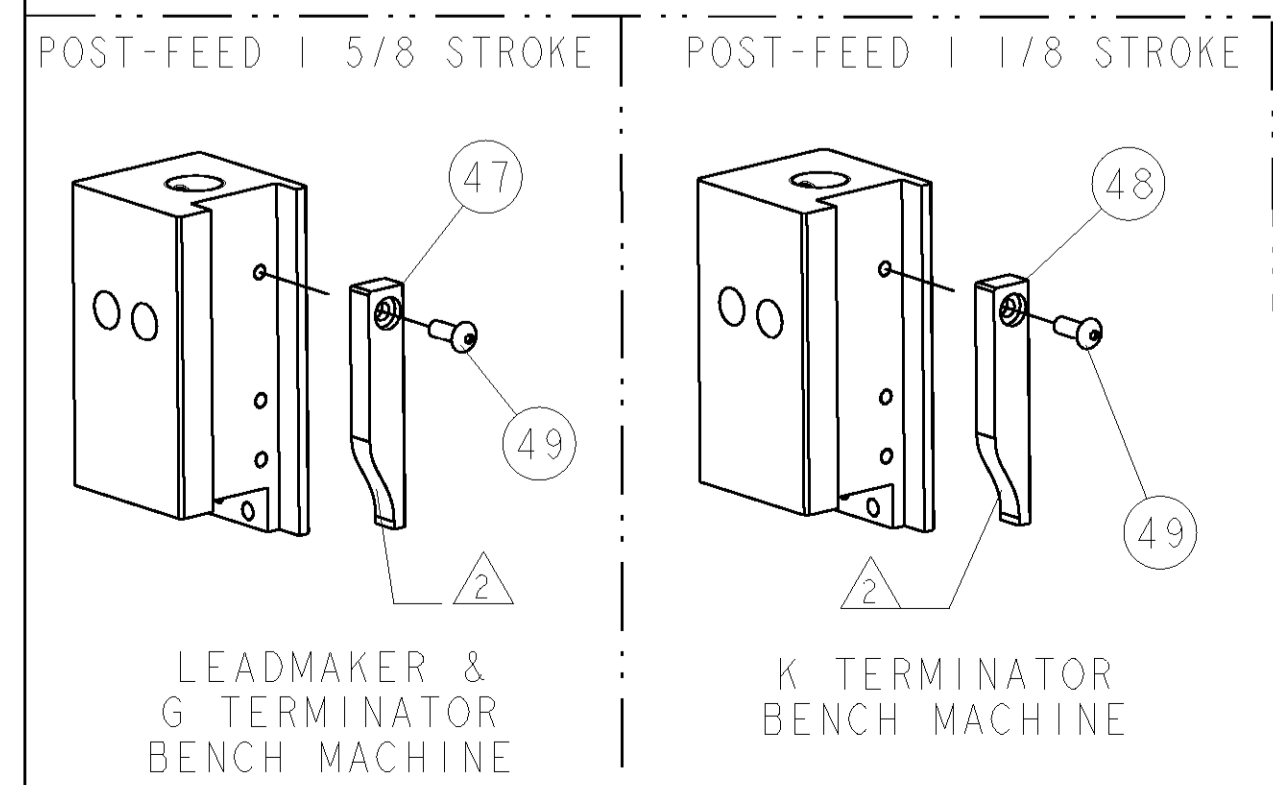

* WARNING:
ON INSTALLATION, SET WIRE DISC TO LARGEST WIRE SIZE SETTING. USE OF SETTINGS BELOW MIN REQUIRED CRIMP HEIGHT SETTING WILL CAUSE DAMAGE TO CRIMP TOOLING.

DIMENSIONS: INCHES		TOLERANCES UNLESS OTHERWISE SPECIFIED:		DRAWN: R. O. WILSON 24MAR2006		CHK: R. O. WILSON 24MAR2006		APVD: J. ELBIN 29MAR2006		NAME: T. ELBIN		PRODUCT SPEC: -		APPLICATION SPEC: -		WEIGHT: -		MATERIAL: -		FINISH: -			
0 PLC	±	1 PLC	±0.1	2 PLC	±0.01	3 PLC	±0.001	4 PLC	±0.0001	ANGLES	±	SIZE: A1		CAGE CODE: 00779		DRAWING NO: C=1855064		SCALE: 3:5		SHEET 1 OF 1		REV A	
CUSTOMER DRAWING												CUSTOMER VIEWABLE ASSEMBLY											