

THIS DRAWING IS UNPUBLISHED. RELEASED FOR PUBLICATION

PART NUMBER	REV	TERMINATOR	FEED TYPE	DESCRIPTION
1528607-1	C	LEADMAKER	MECH POST FEED	CUTS CARRIER
1528607-2	C	BENCH	MECH PRE FEED	CUTS CARRIER
1528607-6	C	LEADMAKER	MECH POST FEED	CONTINUOUS CARRIER
7-1528607-1	C	LEADMAKER	MECH POST FEED	-1 AND SPARE PARTS
7-1528607-2	C	BENCH	MECH PRE FEED	-2 AND SPARE PARTS
7-1528607-6	C	LEADMAKER	MECH POST FEED	-6 AND SPARE PARTS
7-1528607-7	A	-	-	SPARE PARTS KIT

WIRE	SIZE	TYPE	RANGE
WIRE	1.85 [.073 IN]	F	0.56-1.00mm ² (20-18 AWG)
INSUL	3.94 [1.55 IN]	O	3.40 MAX [1.34 IN MAX]

WIRE STRIP LENGTH	APPL INSTRUCTIONS
3.90-4.70 [1.54-1.85 IN]	408-8322 & 408-8490

TERMINAL APPL SPEC	APPL DRG	FEED
2 99 00 47295 1		13.00 [.512 IN]

TYCO TERM PN	MFR TERM PN	TYCO SEAL PN	MFR SEAL PN
1-957401-1	22140492060	957402-1	10800444522
1-957401-2	22124492060	-	-

WIRE SIZE	CRIMP HEIGHT	REF SETTING
1.00mm ²	1.46 ±0.05 [.057 ±.002 IN]	B3
0.90mm ² or 18 AWG	1.38 ±0.05 [.054 ±.002 IN]	C0
0.75mm ²	1.38 ±0.05 [.054 ±.002 IN]	C0
0.56mm ² or 20 AWG	1.30 ±0.05 [.051 ±.002 IN]	C3

- △ RECOMMENDED SPARE PARTS
- 2. GREASE RAM, CAM, CAM FOLLOWER AND FEED ROD LIGHTLY
- 3. LUBRICATE DAILY PER THE APPLICATOR INSTRUCTION SHEET SUPPLIED WITH THE APPLICATOR
- △ THIS APPLICATOR APPLIES TERMINAL WITH A SEAL. INSULATION DIA QUOTED IS OUTSIDE DIAMETER OF SEAL. WIRE INSULATION DIA IS DEPENDENT ON SEAL BEING APPLIED.
- △ APPLY TORQ-SEAL IN ALLEN SOCKET TO FILL HOLE AFTER FLAT HD HAS BEEN ADJUSTED TO CORRECT HEIGHT AT QUALIFICATION. APPLY #1-23419-5 LOC-TITE TO THREADS.
- △ CRIMP WIDTHS CALCULATED BY TYCO ELECTRONICS BASED UPON KOSTAL CRIMP HEIGHTS.

* WARNING
ON INSTALLATION, SET WIRE DISC TO LARGEST WIRE SIZE SETTING. USE OF SETTINGS BELOW MIN. REQUIRED CRIMP HEIGHT SETTING WILL CAUSE DAMAGE TO CRIMP TOOLING.

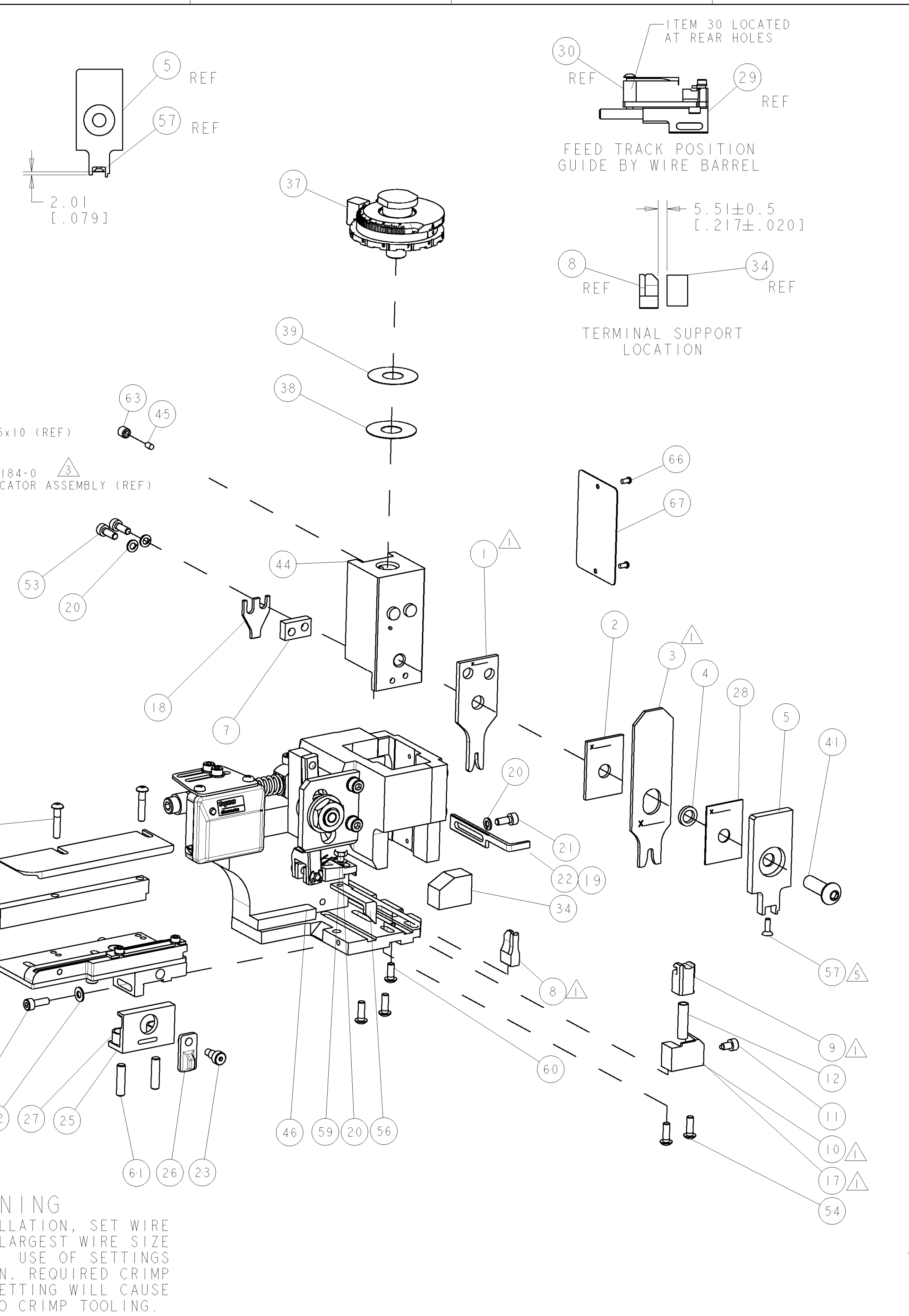
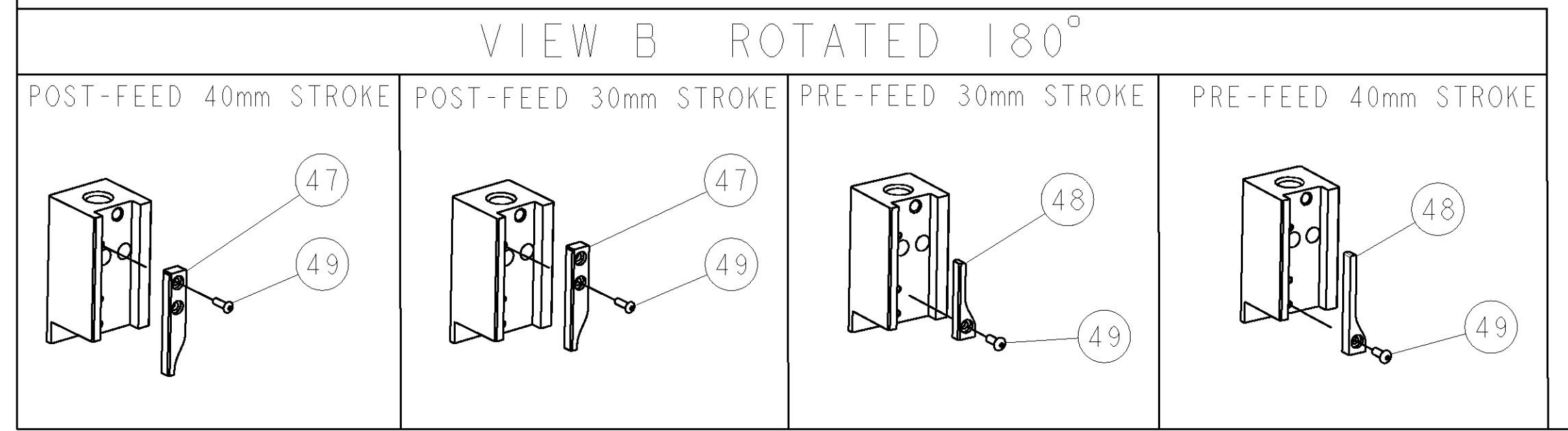

SET UP GAGE
458637-3

REV	DATE	BY	CHK	DESCRIPTION
B	29AUG2006	RK	GB	ECR-06-020826
C	20SEP2006	MC	MC	SEE ECR-06-022369

REV	DATE	BY	CHK	DESCRIPTION	ITEM NO
-	-	-	-	-	73
-	-	-	-	-	72
-	-	-	-	-	71
-	-	-	-	-	70
-	-	-	-	-	69
-	-	-	-	-	68
-	-	-	-	-	67
-	-	-	-	-	66
-	-	-	-	-	65
-	-	-	-	-	64
-	-	-	-	-	63
-	-	-	-	-	62
-	-	-	-	-	61
-	-	-	-	-	60
-	-	-	-	-	59
-	-	-	-	-	58
-	-	-	-	-	57
-	-	-	-	-	56
-	-	-	-	-	55
-	-	-	-	-	54
-	-	-	-	-	53
-	-	-	-	-	52
-	-	-	-	-	51
-	-	-	-	-	50
-	-	-	-	-	49
-	-	-	-	-	48
-	-	-	-	-	47
-	-	-	-	-	46
-	-	-	-	-	45
-	-	-	-	-	44
-	-	-	-	-	43
-	-	-	-	-	42
-	-	-	-	-	41
-	-	-	-	-	40
-	-	-	-	-	39
-	-	-	-	-	38
-	-	-	-	-	37
-	-	-	-	-	36
-	-	-	-	-	35
-	-	-	-	-	34
-	-	-	-	-	33
-	-	-	-	-	32
-	-	-	-	-	31
-	-	-	-	-	30
-	-	-	-	-	29
-	-	-	-	-	28
-	-	-	-	-	27
-	-	-	-	-	26
-	-	-	-	-	25
-	-	-	-	-	24
-	-	-	-	-	23
-	-	-	-	-	22
-	-	-	-	-	21
-	-	-	-	-	20
-	-	-	-	-	19
-	-	-	-	-	18
-	-	-	-	-	17
-	-	-	-	-	16
-	-	-	-	-	15
-	-	-	-	-	14
-	-	-	-	-	13
-	-	-	-	-	12
-	-	-	-	-	11
-	-	-	-	-	10
-	-	-	-	-	9
-	-	-	-	-	8
-	-	-	-	-	7
-	-	-	-	-	6
-	-	-	-	-	5
-	-	-	-	-	4
-	-	-	-	-	3
-	-	-	-	-	2
-	-	-	-	-	1

REV	DATE	BY	CHK	DESCRIPTION	ITEM NO
-	-	-	-	-	83
-	-	-	-	-	82
-	-	-	-	-	81
-	-	-	-	-	80
-	-	-	-	-	79
-	-	-	-	-	78
-	-	-	-	-	77
-	-	-	-	-	76
-	-	-	-	-	75
-	-	-	-	-	74
-	-	-	-	-	73
-	-	-	-	-	72
-	-	-	-	-	71
-	-	-	-	-	70
-	-	-	-	-	69
-	-	-	-	-	68
-	-	-	-	-	67
-	-	-	-	-	66
-	-	-	-	-	65
-	-	-	-	-	64
-	-	-	-	-	63
-	-	-	-	-	62
-	-	-	-	-	61
-	-	-	-	-	60
-	-	-	-	-	59
-	-	-	-	-	58
-	-	-	-	-	57
-	-	-	-	-	56
-	-	-	-	-	55
-	-	-	-	-	54
-	-	-	-	-	53
-	-	-	-	-	52
-	-	-	-	-	51
-	-	-	-	-	50
-	-	-	-	-	49
-	-	-	-	-	48
-	-	-	-	-	47
-	-	-	-	-	46
-	-	-	-	-	45
-	-	-	-	-	44
-	-	-	-	-	43
-	-	-	-	-	42
-	-	-	-	-	41
-	-	-	-	-	40
-	-	-	-	-	39
-	-	-	-	-	38
-	-	-	-	-	37
-	-	-	-	-	36
-	-	-	-	-	35
-	-	-	-	-	34
-	-	-	-	-	33
-	-	-	-	-	32
-	-	-	-	-	31
-	-	-	-	-	30
-	-	-	-	-	29
-	-	-	-	-	28
-	-	-	-	-	27
-	-	-	-	-	26
-	-	-	-	-	25
-	-	-	-	-	24
-	-	-	-	-	23
-	-	-	-	-	22
-	-	-	-	-	21
-	-	-	-	-	20
-	-	-	-	-	19
-	-	-	-	-	18
-	-	-	-	-	17
-	-	-	-	-	16
-	-	-	-	-	15
-	-	-	-	-	14
-	-	-	-	-	13
-	-	-	-	-	12
-	-	-	-	-	11
-	-	-	-	-	10
-	-	-	-	-	9
-	-	-	-	-	8
-	-	-	-	-	7
-	-	-	-	-	6
-	-	-	-	-	5
-	-	-	-	-	4
-	-	-	-	-	3
-	-	-	-	-	2
-	-	-	-	-	1

DIMENSIONS: mm [IN] 	TOLERANCES UNLESS OTHERWISE SPECIFIED: 0 PLC ± 1 PLC ± 2 PLC ± 3 PLC ± 4 PLC ± ANGLES ±	DIMENSIONS: mm [IN] 	TOLERANCES UNLESS OTHERWISE SPECIFIED: 0 PLC ± 1 PLC ± 2 PLC ± 3 PLC ± 4 PLC ± ANGLES ±
MATERIAL: - FINISH: -		WEIGHT: -	
CUSTOMER DRAWING: -		SCALE: 3:5 SHEET 1 OF 1 REV C	