

LOC		DIST		REVISIONS			
P	LTR	DESCRIPTION	DATE	DMN	APVD		
H		REV PER ECO 15-005909	5-19-15	CT	DM		

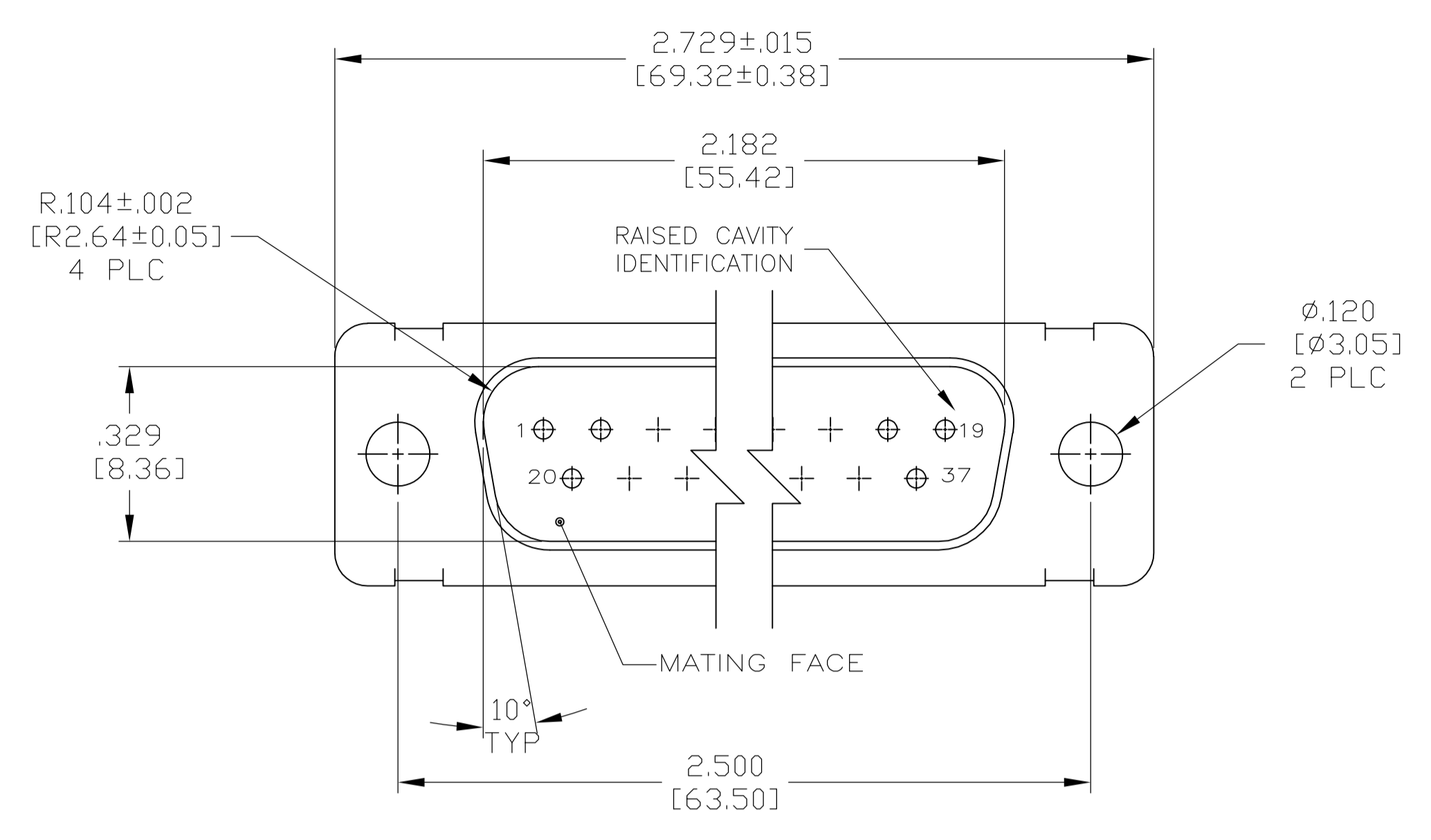

- THIS CONNECTOR ASSEMBLY IS SUPPLIED WITH Be Cu CONTACT RETENTION CLIPS INSTALLED IN THE INSERT ASSEMBLY.
 - THIS CONNECTOR ASSEMBLY MATES WITH ANY PLUG CONNECTOR WITH THE SAME INSERT ARRANGEMENT AND DIMENSIONAL REQUIREMENTS PER MIL-C-24308.
 - MARKED WITH .047 [1.19]-.062 [1.57] HIGH CHARACTERS. FAR SIDE REFERS TO THE WIDE SIDE OF THE KEYSTONE. NEAR SIDE REFERS TO THE NARROW SIDE OF THE KEYSTONE.
 - MAXIMUM WIRE INSULATION TO BE USED WITH THIS CONNECTOR ASSEMBLY IS .054 [1.37] DIAMETER.
- SPECIAL REQUIREMENTS PER BOEING 1A01 DOCUMENT.
- BUILT TO ORDER, NO INVENTORY OF THIS PART NUMBER IS TO BE KEPT. SINGLE LOT DATE CODE REQUIRED.

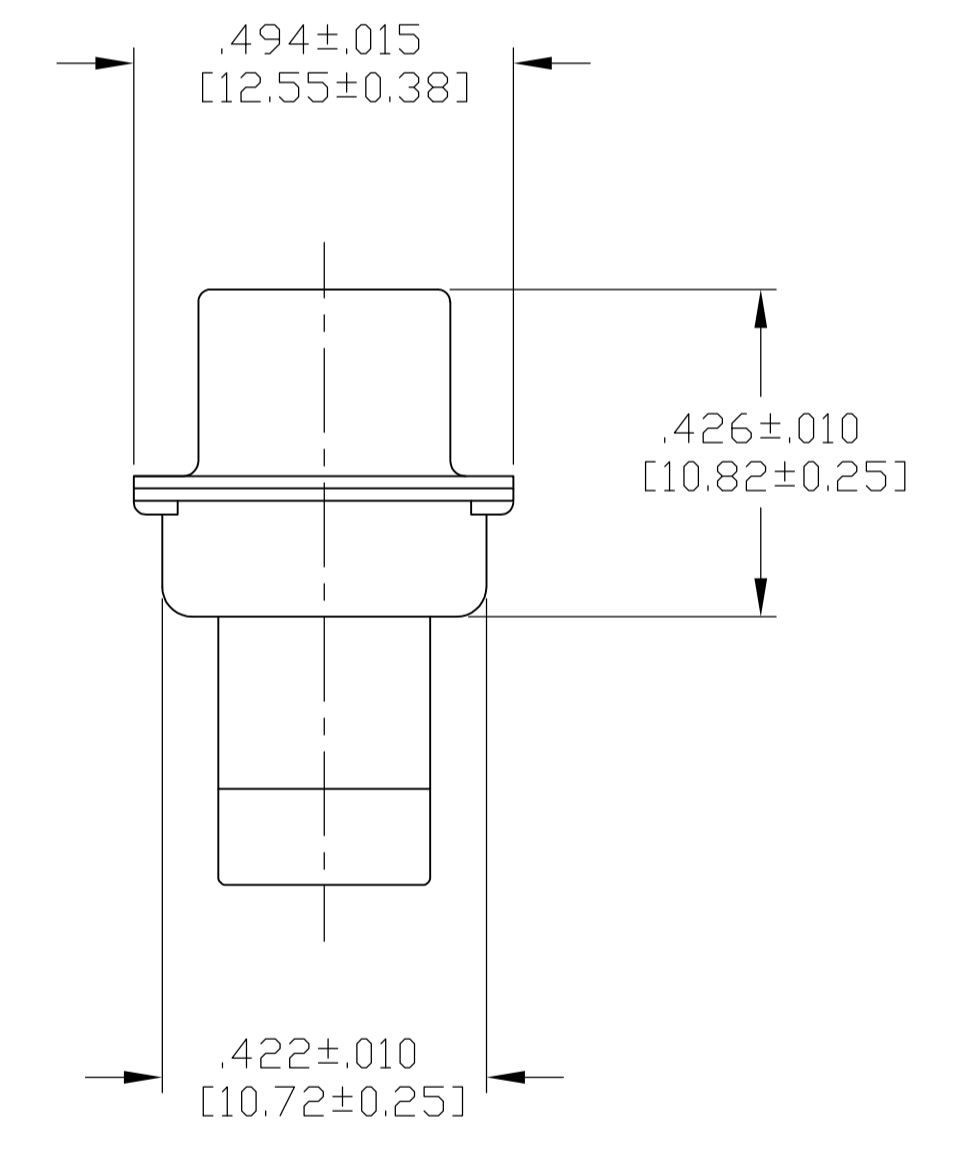
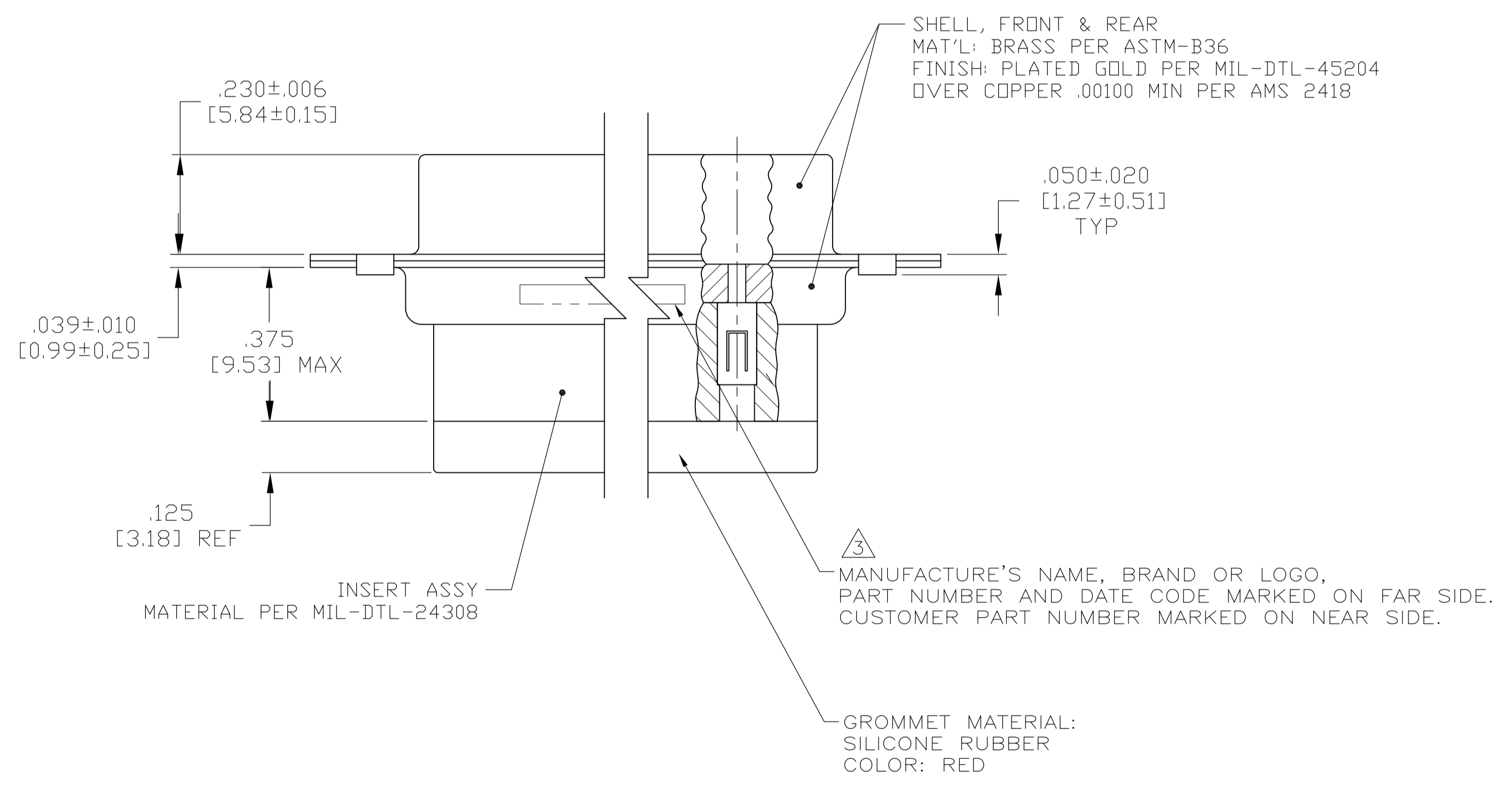

6 7	1A01-029PHW	1-211641-1
--	---	211641-4
6 7	1A01-029PHA	211641-1
REMARKS	CUSTOMER MARKING	PART NUMBER

THIS DRAWING IS A CONTROLLED DOCUMENT.

DIMENSIONS: INCHES	TOLERANCES UNLESS OTHERWISE SPECIFIED:	0 PLC ± -	1 PLC ± -	2 PLC ± -	3 PLC ± .005 [0.13]	4 PLC ± -	ANGLES ± -
MATERIAL SEE CALLOUTS	FINISH SEE CALLOUTS	WEIGHT	SIZE	CAGE CODE	DRAWING NO	RESTRICTED TO	
			A1	00779	211641		

CUSTOMER DRAWING SCALE 4:1 SHEET 1 OF 1 REV H