

REVISIONS					
P	LTR	DESCRIPTION	DATE	DWN	APVD
C2		REVISED PER ECR-21-113405	31MAY2022	SS	DH

- 1 CONTINUOUS STRIP ON REELS
- 2 MATING TAB THK TO BE  $.032 \pm .001$
- 3 WIRE SIZE IS #12-#10 AWG.
- 4 INSULATION RANGE IS  $.140-.200$  DIA
- 5 THE GAP ON THE ROLLS TO BE IN CONTACT WITH THE TAB FOR THE LENGTH OF THE ROLL BEHIND THE LEAD-IN.

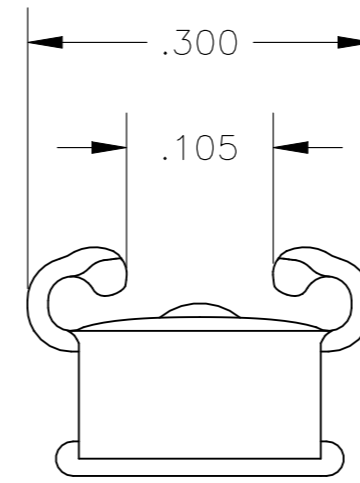

VIEW A-A  
SCALE 8:1

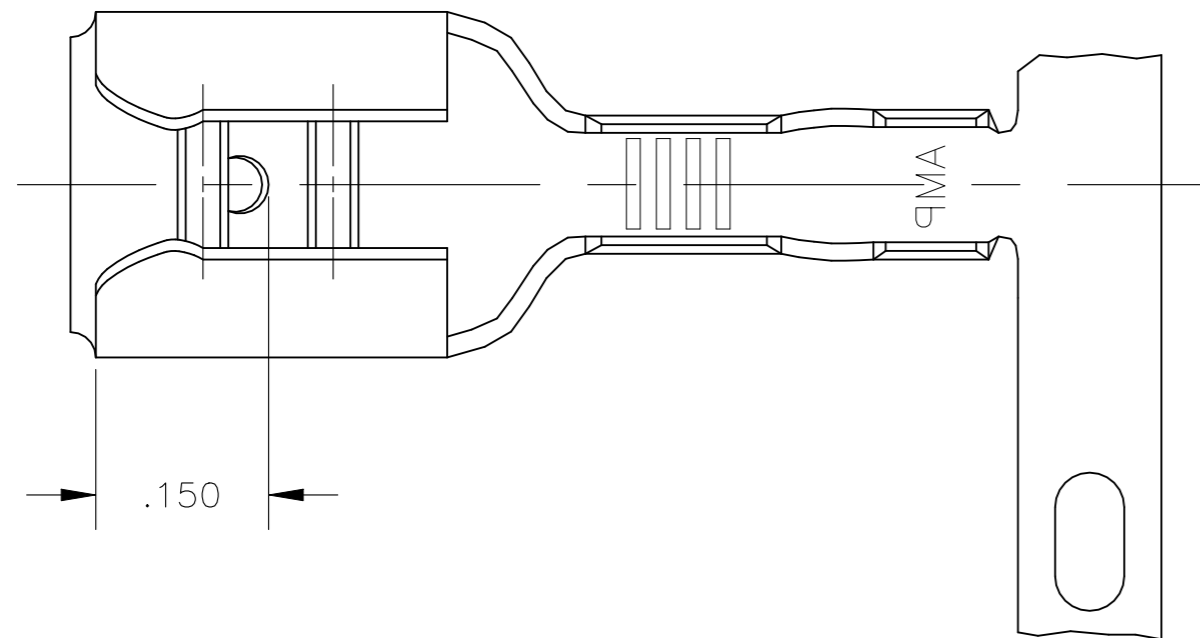
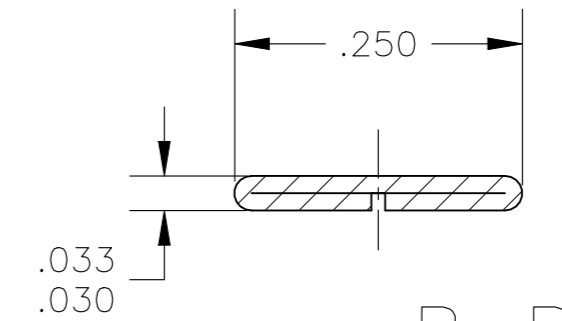

SECTION B-B  
SCALE 8:1

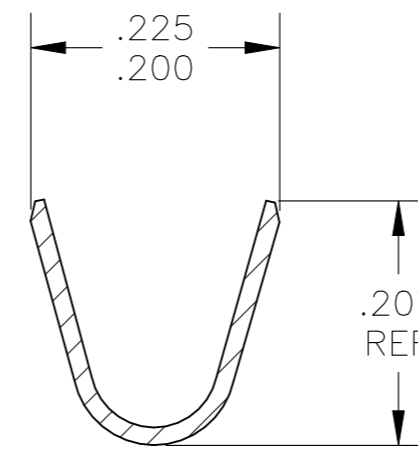
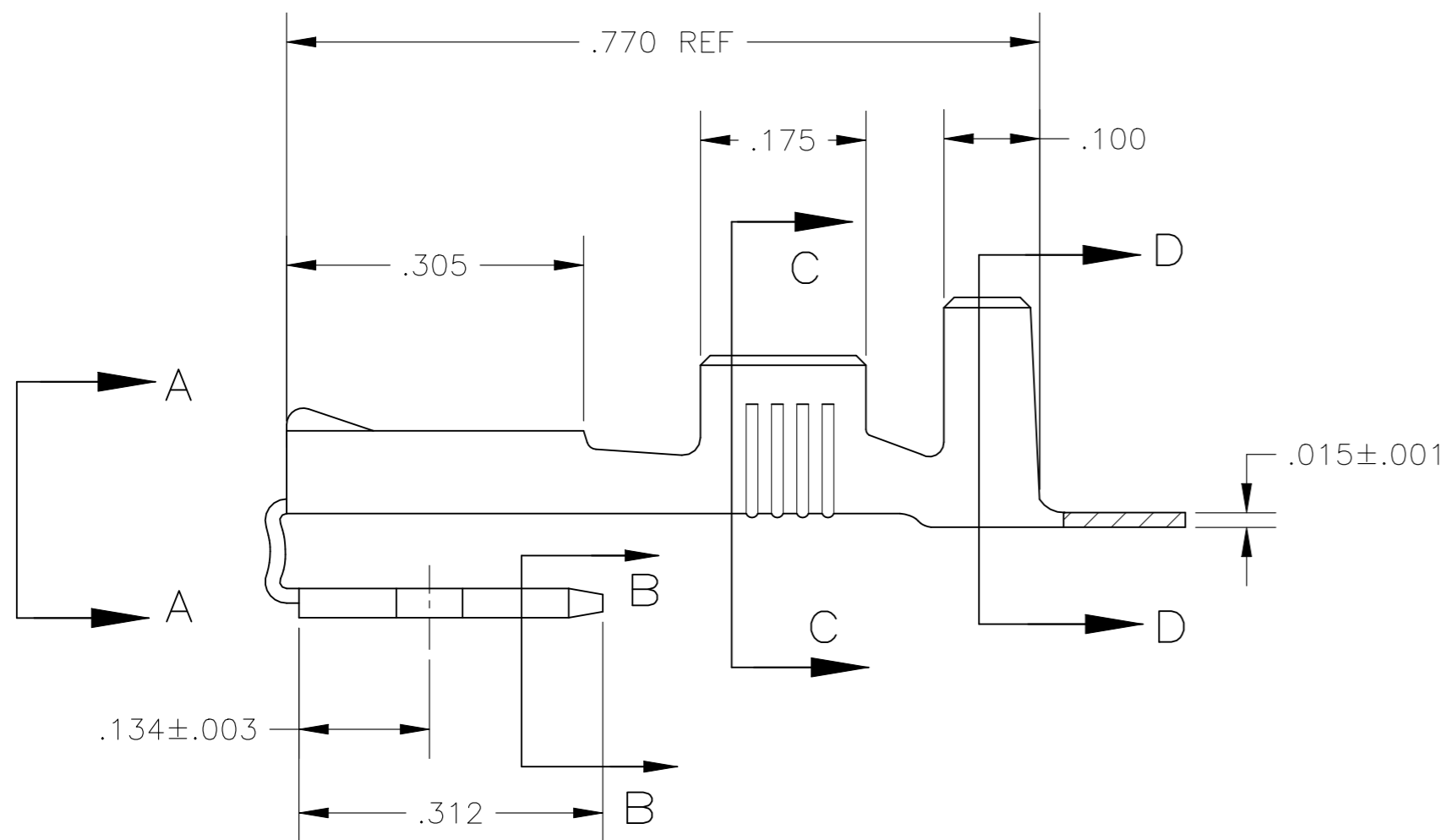

SECTION C-C  
SCALE 8:1

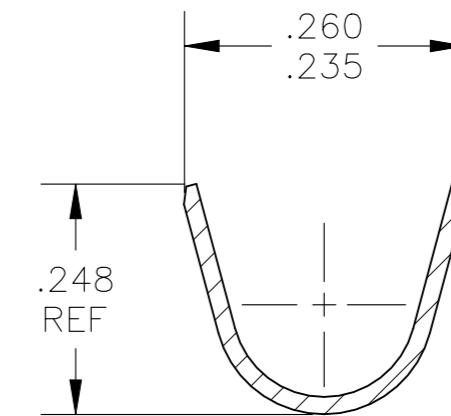

SECTION D-D  
SCALE 8:1

TIN	1742402-2
OBSOLETE	1742402-1
FINISH	PART NO

THIS DRAWING IS A CONTROLLED DOCUMENT.		DWN	JR_RUTH	02FEB06
DIMENSIONS:		CHK	P_DESANTIS	02FEB06
INCHES		APVD	P_DESANTIS	02FEB06
TOLERANCES UNLESS OTHERWISE SPECIFIED:		PRODUCT SPEC	NAME	
0 PLC	$\pm -$	APPLICATION SPEC	RECEPTACLE, FASTON, PIGGYBACK, .250 SERIES	
1 PLC	$\pm -$	114-2082	SIZE	A2
2 PLC	$\pm -$	WEIGHT	CAGE CODE	00779
3 PLC	$\pm .010$	CUSTOMER DRAWING	DRAWING NO	C=1742402
4 PLC	$\pm -$		RESTRICTED TO	-
ANGLES	$\pm -$		SCALE	6:1
FINISH	SEE TABLE		SHEET	1 of 1
MATERIAL	BRASS		REV	C2