

NOTES:

1. PLATING MUST CONFORM TO AMPHENOL SPEC 349-50560. CONNECTOR IS GOLD PLATED.
2. FOR ASSEMBLY INSTRUCTIONS SEE AMPHENOL SPEC 349-50521, SHEET 3.

903-291P-51A

REVISIONS

DRAWING NO.	REV	DESCRIPTION	DATE	ECO	APPR
THIRD ANGLE PROJ.	A	OFFICIAL ENG. RELEASE TO MFG.	4-11-90	37203	TA/PB
	G	REVISED	4/9/96	41239	PB/
	H	SEE SHEET 1	10/6/06	46294	CPM

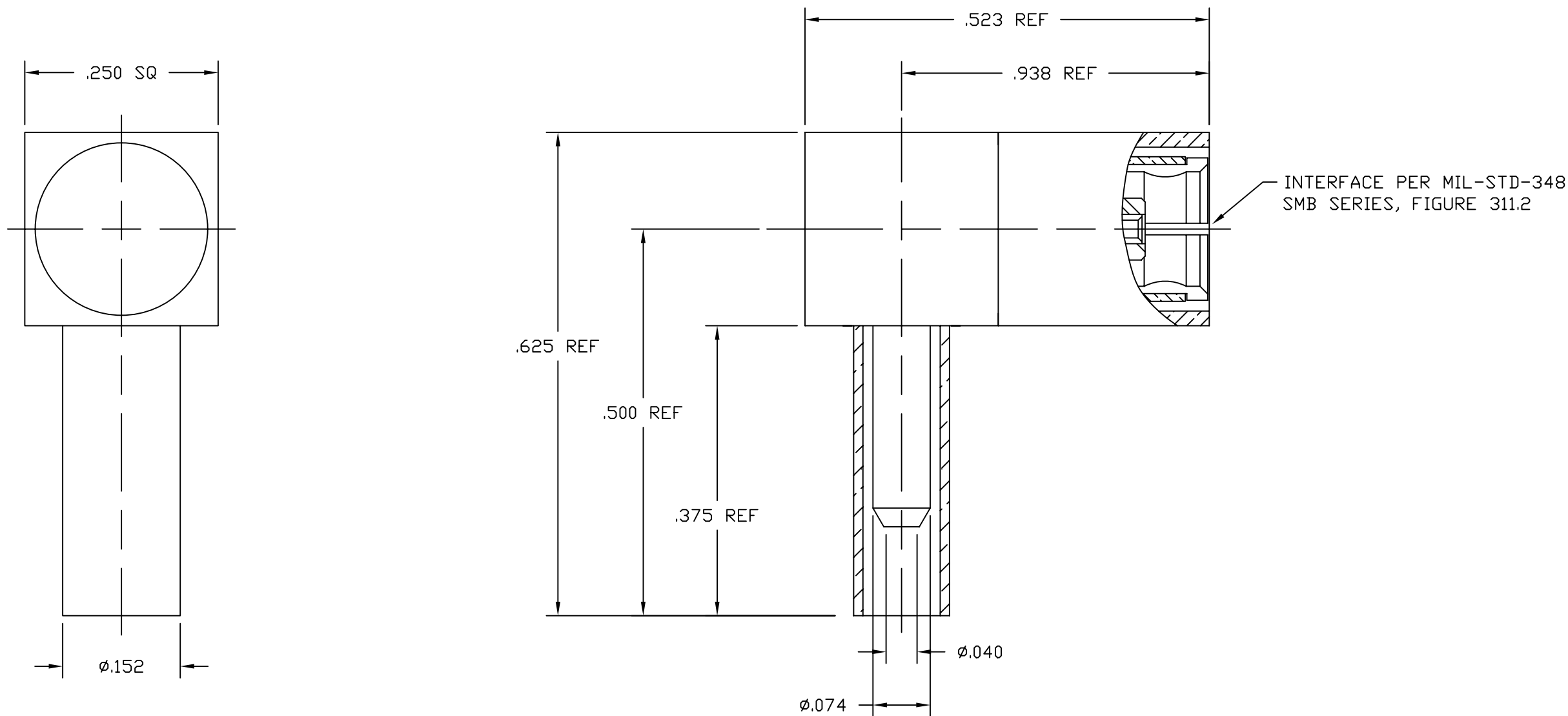

CUSTOMER OUTLINE DRAWING
ALL OTHER SHEETS ARE FOR INTERNAL USE ONLY

UNLESS OTHERWISE SPECIFIED, DIMENSIONS ARE IN INCHES AND TOLERANCES ARE:
2 PLACE DECIMAL 3 PLACE DECIMAL ANGLES
±.015 (0,381 mm) ±.005 (0,127 mm) ± 1'

NOTICE - These drawings, specifications, or other data (1) are, and remain the property of Amphenol Corp. (2) must be returned upon request; and (3) are confidential and not to be disclosed to any person other than those to whom they are given by Amphenol Corp. The furnishing of these drawings, specifications, or other data by Amphenol Corp., or to any other person to anyone for any purpose is not to be regarded by implication or otherwise in any manner licensing, granting rights or permitting such holder or any other person to manufacture, use or sell any product, process or design, patented or otherwise, that may in any way be related to or disclosed by said drawings, specifications, or other data.

MATERIAL	DRAWN T. ALBERA	DATE 4-11-90
REFERENCE	ENGINEER P. BRENZEL	DATE 4-11-90
	APPROVED B. C GLEISSNER	DATE 4/3/96
	CAD FILE H:\PETE\SMB\903\ASSY\291P51AC	

TITLE SMB RIGHT ANGLE PLUG, CRIMP TYPE FOR RG-196/U
CODE ID 74868
DWG SIZE B
DRAWING NO. 903-291P-51A
REV H

SCALE: 6:1	SHEET 2 OF 2
------------	--------------

<p>Amphenol Amphenol Corporation RF/Microwave Operations Danbury, Conn. U.S.A. 06810</p>	
---	--