



Perle Fast Ethernet Media Converters

Installation Guide

S-100-XXXXX



Overview

This document contains instructions necessary for the installation and operation of the Perle Fast Ethernet Standalone Media Converters (S-100). These products convert a 100Base-TX cable connection (copper) to a 100Base-X connection (fiber). The fiber connection can be either single mode (SM) or multimode (MM) and can operate over different wavelengths and distances, depending on the model selected (see table below).

Model	Connector	Mode - Distance	Wavelength
S-100-M2xx2	SC/ST/LC	MM - 2 km/1.2 mi.	1310 nm
S-100-S2xx20	SC/ST/LC	SM - 20 km/12.4 mi.	1310 nm
S-100-S2xx40	SC/ST/LC	SM - 40 km/24.9 mi.	1310 nm
S-100-S2xx80	SC/ST/LC	SM - 80 km/49.7 mi.	1550 nm
S-100-S2xx120	SC/ST/LC	SM - 120 km/74.6 mi	1550 nm
S-100-S1SC20U	SC	SM - 20 km/12.4 mi.	1310/1550 nm
S-100-S1SC20D	SC	SM - 20 km/12.4 mi.	1550/1310 nm
S-100-S1SC40U	SC	SM - 40 km/24.9 mi.	1310/1550 nm
S-100-S1SC40D	SC	SM - 40 km/24.9 mi.	1550/1310 nm

Note: Please refer to Perle's web site for the most up to date Installation guides, models and specifications:

<http://www.perle.com/>

Installation

The default switch settings (all switches in the UP position) will work for most installations.

There are five steps required to configure the Perle Fast Ethernet media converter:

1. Set the Auto-MDIX jumper setting (optional).
2. Set the switch settings (optional).
3. Install and connect the fiber cable.
4. Install and connect the copper cable.
5. Power up the media converter.

Auto MDIX Jumper Settings

Note: The factory settings for Auto-MDIX will work for most installations, but in the rare case that you need to modify the settings, the procedure is below.

To access the Auto-MDIX jumper settings, unscrew the four side screws on the top case and remove the cover plate. Locate the MDIX AUTO jumper set as detailed below. By covering or strapping pins 1 and 2, the S-100 will operate as an MDIX device. By covering or strapping pins 2 and 3, the S-100 will automatically detect the Ethernet cable's polarity. Removing the strapping is the same as AUTO.

NOTE: The default jumper setting is Auto

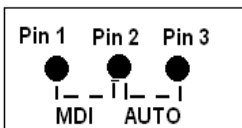

DIP Switches

The DIP switches are accessible through the opening in the side of the enclosure

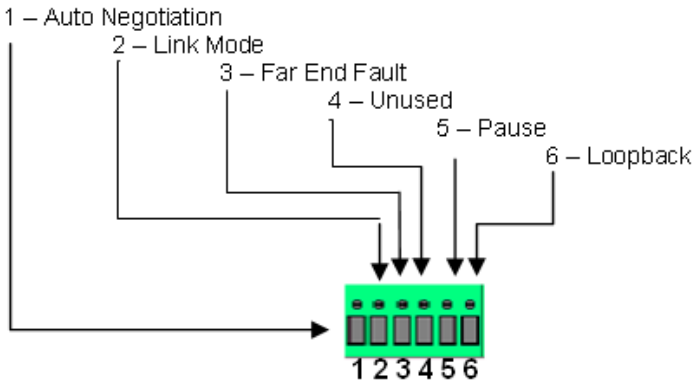

Note: All switch changes take effect immediately and will result in a link reset on both ports.

DIP Switch Settings

Auto Negotiation (Switch 1)

Switch Position	Mode
Up (default)	Auto
Down	Off

Auto: In this mode of operation the media converter will negotiate Ethernet parameters on the copper connection. This will ensure the most optimal connection parameters will be in effect. If the copper link partner does not support Auto negotiation, the S-100 will default to 100 Mbps and Half Duplex mode.

Off: Auto Negotiation should only be turned off, if the copper link partner does not support Auto Negotiation.

When the Auto Negotiation switch is set to the OFF position, the media converter will operate at 100 Mbps and Full Duplex mode.

Link Mode (Switch 2)

Switch Position	Mode
Up (default)	Link Pass-Through Mode
Down	Standard Mode

Link Pass-Through: In this mode, the link state on one connection is directly reflected through the media converter to the other connection. If link is lost on one of the connections, then the other link will be brought down by the media converter.

If the installation has a media converter on both ends of the fiber link and both are setup for Link Pass-Through, then a loss of copper link on the far end device will propagate through both media converters and will result in a loss of copper link at the near end device. This would, therefore, resemble a direct copper connection.

Standard Mode: In this mode, the links on the fiber and copper sides can be brought up and down independently of each other. A loss of link on either the fiber ports or copper ports can take place without affecting the other connection.

Far End Fault (Switch 3)

Switch Position	Mode
Up (default)	Enabled
Down	Disabled

Enabled: If the media converter detects a loss of fiber signal on the fiber receiver, it will immediately send a FEF on the fiber link. This, in effect, notifies the fiber link partner that an error condition exists on the fiber connection.

If the remote media converter is set up for Far End Fault (FEF) and the local media converter is set up with Link Pass-Through, a loss of fiber link on either the transmit or receive line will be passed through to the local copper connection thus notifying the connected device.

If the media converter has been set to Link Pass-Through mode, the effect will be the same as FEF, since the link loss on the fiber receiver will bring down the copper link, which will in turn cause the transmit fiber link to be brought down.

Note: This switch needs to be set to either generate or detect the FEF signal.

Disabled: The media converter will not monitor for or generate Far End Fault.

The following diagram is an illustration of the operation of this feature.

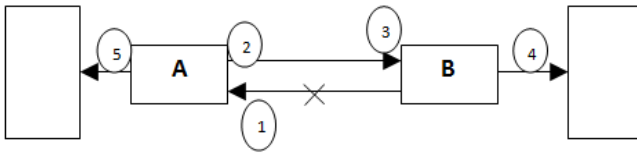

(A) – Remote Media Converter setup for Far End Fault Enabled, Auto Negotiation – OFF and Link Mode – Standard.

(B) – Local Media Converter setup for Link Pass-Through and Auto Negotiation - OFF

- 1 – **(A)** loses fiber connection on its receiver
- 2 – **(A)** sends an FEF
- 3 – **(B)** detects loss of link in its fiber receiver
- 4 – **(B)** drops link on copper connection through Link Pass-Through
- 5 – **(A)** Link on copper connection is not affected.

Unused (Switch 4)

Pause (Switch 5)

Switch Position	Mode
Up (default)	Enabled
Down	Disabled

Enabled: When Auto Negotiation has been set to Auto (SW 1), the media converter will use this setting for its Ethernet parameter negotiation on the copper connection.

Disable: The media converter will not negotiate support for the Pause feature.

Note: The media converter will not act on, or generate any Ethernet Pause messages, but will pass them through to the end device. This switch setting is provided so that the attached device (near end) can negotiate its Ethernet parameters as if it was negotiating directly with the far end device. The Pause switch setting on the media converter should match the capabilities of the far end device.

Loopback (Switch 6)

Switch Position	Mode
Up (default)	Disabled
Down	Enabled

Disabled: The loopback feature is disabled. This is the normal position for regular operation. The switch must be set to this position in order for data to pass through the media converter.

Enabled: This is a test mode. All data received on the receive (RX) fiber connection is looped back to the transmit (TX) fiber connection. The state of the copper is not relevant and no data or link status is passed through to the copper side.

Installing the Duplex Fiber Cable

- Locate a 100Base-X compliant duplex (2 strands) fiber cable with male connections.
- Connect the fiber cables from one media converter to the other media converter/switch/fiber device ensuring that the RX and TX are reversed at the opposite end.

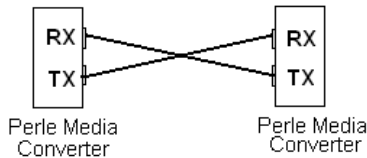

Installing the Simplex Fiber Cable

- Locate a 100Base-X compliant simplex (1 strand) fiber cable with male connections.
- Connect the fiber cable from one media converter to the other media converter/switch/fiber device.

Installing the Copper Cable

- Locate 100Base-TX compliant copper cables with male, RJ-45 connectors installed at both ends.
- Connect the RJ-45 cable between the Perle media converter and the device.

Note: The Perle media converter supports Auto-MDIX, therefore a straight-through or cross over Ethernet cable may be used. See page three in this guide for jumper positions.

Powering up the Perle Media Converter

- Connect the Perle supplied power adapter to the media converter.
- Turn on the power at source.
- Check that the PWR LED light is lit and on solid.

Operation

Status LED

The Perle Fast Ethernet Media converters have three single color status LEDs located on the front panel of the unit.

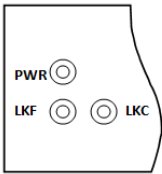

PWR - Power/Test

- **On:** Power is on and in normal operation.
- **Blinking *slowly*:** the unit is in loopback mode.
- **Blinking *quickly*:** the unit has a hardware error.

LKF - Fiber Link/Activity

- **On:** Fiber link present.
- **Blinking *quickly*:** Fiber link present and receiving data.
- **Off:** No fiber link present.

LKC - Copper Link/Activity

- **On:** Copper link is present.
- **Blinking *quickly*:** Copper link present and receiving data.
- **Off:** No copper link present.

Other Features

Auto-MDIX:

Auto-MDIX (automatic medium-dependant interface crossover) detects the signalling on the 100BASE-T interface to determine the type of cable connected (straight-through or crossover) and automatically configures the connection.

Error Recovery:

In certain configurations, and under specific conditions where the media converter brings down a link to convey status, there is potential for a deadlock. Recovery is achieved by momentarily restoring the link to see if the original failure has been resolved. If it has not, the link will be forced down again, however if the original problem has been resolved, the link will be restored.

Troubleshooting

General

- Ensure power is supplied to the media converter – use of the supplied power adapters is highly recommended.
- Ensure both devices on either end of the fiber are compatible. If using a simplex fiber connection, ensure that you have both an Upstream (U) and Downstream (D) media converter.
- Ensure all cabling is of the correct type and is in good working order..
- For duplex fiber connections, ensure the RX and TX has been reversed between the 2 media converters.

No connectivity

If unable to get full connectivity with all DIP switches in the UP position, this procedure is recommended for troubleshooting.

Method 1

- 1) Set the Link mode to Standard (SW2 – Down) on both media converters. Leave all other switches in the Up position.
- 2) Connect the near end device to the copper connection. The LKC LED indicates good copper connection. If the LKC LED is not lit, then check the copper cable and the attached device.
- 3) Repeat for the far end media converter.
- 4) Connect the fiber cable to both media converters. The LKF LED indicates good fiber connection. If no LKF LED then check the fiber cabling.
- 5) Return units to desired configuration.

Method 2:

The fiber connection can also be verified by configuring the remote media converter for loopback mode. The LKF LEDs on both media converters should be lit. Data should pass through the local converter, over the fiber connection to the remote media converter. At the remote media converter, the data will be looped back and passed through the fiber, once again, to pass through the local converter to the copper link.

Technical Specifications

The following applies to all S-100 media converters:

Power Input/Consumption	12V DC / 2.0 W
Operating Temperature:	0°C to 50°C (32°F to 122°F)
Storage Temperature:	-25°C to 70°C (-13°F to 158°F)
Operating Humidity:	5% to 90% non-condensing
Storage Humidity:	5% to 95% non-condensing
Operating Altitude:	Up to 3,048 m (10,000 ft)
MTBF:	594,645 hours
MTBF (with power supply):	332,606 hours
Weight:	0.3 kg (0.66 lbs)
Dimensions:	80 mm x 120 mm x 26 mm

Fiber Optic Specifications:

Model	Mode	Wavelength (nm)	TX Power (dB)	RX Power (dB)	Budget (dB)
S-100-M2SC2	MM	TX: 1310 RX: 1310	Min: -20 Max: -12	Min: -31 Max: -14	11
S-100-M2ST2	MM	TX: 1310 RX: 1310	Min: -20 Max: -12	Min: -31 Max: -14	11
S-100-M2LC2	MM	TX: 1310 RX: 1310	Min: -20 Max: -12	Min: -30 Max: -14	10
S-100-S2SC20	SM	TX: 1310 RX: 1310	Min: -18 Max: -7	Min: -32 Max: -3	14
S-100-S2ST20	SM	TX: 1310 RX: 1310	Min: -15 Max: -8	Min: -32 Max: -3	17
S-100-S2LC20	SM	TX: 1310 RX: 1310	Min: -15 Max: 0	Min: -34 Max: -5	19
S-100-S2SC40	SM	TX: 1310 RX: 1310	Min: -5 Max: 0	Min: -34 Max: -3	29
S-100-S2ST40	SM	TX: 1310 RX: 1310	Min: -5 Max: 0	Min: -34 Max: -3	29
S-100-S2LC40	SM	TX: 1310 RX: 1310	Min: -5 Max: 0	Min: -34 Max: -3	29
S-100-S2SC80	SM	TX: 1550 RX: 1550	Min: -5 Max: 0	Min: -34 Max: -3	29
S-100-S2ST80	SM	TX: 1550 RX: 1550	Min: -5 Max: 5	Min: -34 Max: -3	29

S-100-S2LC80	SM	TX: 1550 RX: 1550	Min: -5 Max: 0	Min: -34 Max: -3	29
S-100-S2SC120	SM	TX: 1550 RX: 1550	Min: 0 Max: 5	Min: -35 Max: -3	35
S-100-S2ST120	SM	TX: 1550 RX: 1550	Min: 0 Max: 5	Min: -35 Max: 0	35
S-100-S2LC120	SM	TX: 1550 RX: 1550	Min: 0 Max: 5	Min: -35 Max: -3	35
S-100-S1SC20U	SM	TX: 1310 RX: 1550	Min: -14 Max: -8	Min: -32 Max: -3	18
S-100-S1SC20D	SM	TX: 1550 RX: 1310	Min: -14 Max: -8	Min: -32 Max: -3	18
S-100-S1SC40U	SM	TX: 1310 RX: 1550	Min: -8 Max: -3	Min: -33 Max: -3	25
S-100-S1SC40D	SM	TX: 1550 RX: 1310	Min: -8 Max: -3	Min: -33 Max: -3	25

Fiber Cabling Requirements:

- MM:** 50/125 microns or
62.5/125 microns
- SM:** 9/125 microns

Ethernet Copper Cabling Requirements:

- Category 5 UTP or STP
- 24-22 AWG
- Straight through or Ethernet crossover

Note: Please refer the product page on the Perle website for the most up to date specifications.

<http://www.perle.com/>

Compliance Information

FCC

This product has been found to comply with the limits for a Class A digital device, pursuant to Part 15 of the FCC rules. These limits are designed to provide reasonable protection against harmful interference when the equipment is operated in a commercial environment. This equipment generates, uses, and can radiate radio frequency energy and, if not installed and used in accordance with the instructions in this Guide, may cause harmful interference to radio communications. Operation of this equipment in a residential area is likely to cause harmful interference, in which case the user will be required to correct the interference at his/her own expense.

EN 55022 Class B

EN 55024 Class A

Note: When used with a power adapter providing low conducted emissions, the S-100 will comply with Class B requirements.

Laser Safety – IEC 60825-1:2007

This product meets Class I Laser safety requirements per IEC-60825-1:2007 standard and complies with FDA/CDRH 21 CFR1040.10 and 21 CFR1040.11.

WARNING: Visible and invisible laser radiation may be present when cables are not connected. Do not stare into the beam or view the beam directly with optical instruments. Failure to observe this warning could result in an eye injury or blindness.

WARNING: Use of controls, adjustments or the performance of procedures other than those specified herein may result in hazardous radiation exposure.

Warranty / Registration

Perle's standard Lifetime Warranty provides customers with return to factory repairs for Perle products that fail under the conditions of the warranty coverage. Details can be found at:

http://www.perle.com/support_services/warranty.shtml

Contacting Technical Support

Contact information for the Perle Technical Assistance Center (PTAC) can be found at the link below. A Technical Support Query may be made via this web page.

www.perle.com/support_services/support_request.shtml

Copyright

© 2010 **Perle Systems Limited**

All rights reserved. No part of this document may be reproduced or used in any form without written permission from Perle Systems.