

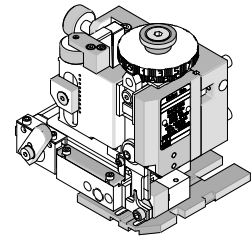

**Mini-Mac  
Applicator**

**Application Tooling  
Specification Sheet**



**Order No. 63888-7000**

**FEATURES**

- Directly adapts to most automatic wire processing machines
- Applicator designed to industry standard mounting and shut height 135.80mm (5.346")
- Quick set-up time; plus the crimp height, track and feed adjustments can be set without removing the applicator from the press
- Fine adjustment allows users to achieve target with little effort by adjusting in increments of .015mm (.0006") for conductor crimp height and .063mm (.0025") for insulation height
- Independent adjustment rings allow users to quickly adjust the conductor or insulation crimp height without affecting each other

**SCOPE**

Products: KK® Cat Ear and Anti Fish Hook Crimp Terminals, 22-30 AWG.

| Terminal Series No. | Terminal Order No. |            |            |            | Wire Size |                 | Insulation Diameter |           | Strip Length |           |
|---------------------|--------------------|------------|------------|------------|-----------|-----------------|---------------------|-----------|--------------|-----------|
|                     |                    |            |            |            | AWG       | mm <sup>2</sup> | mm                  | In.       | mm           | In.       |
| 4809                | 08-50-0030         | 08-50-0031 | 08-50-0033 | 08-50-0135 | 22-30     | 0.35-0.05       | 1.12-1.57           | .044-.062 | 2.54-3.18    | .100-.125 |
|                     | 08-55-0110         | 08-55-0112 | 08-56-0120 | 08-56-0158 |           |                 |                     |           |              |           |
|                     | 40-01-0829         | 97-00-0450 | 97-00-0452 |            |           |                 |                     |           |              |           |
| 8088                | 08-52-0103         | 08-52-0105 | 08-52-0107 | 08-65-0105 | 22-30     | 0.35-0.05       | 1.12-1.57           | .044-.062 | 2.54-3.18    | .100-.125 |
|                     | 40-07-0812         | 97-00-0225 | 97-00-0227 |            |           |                 |                     |           |              |           |
|                     |                    |            |            |            |           |                 |                     |           |              |           |

**DEFINITION OF TERMS**

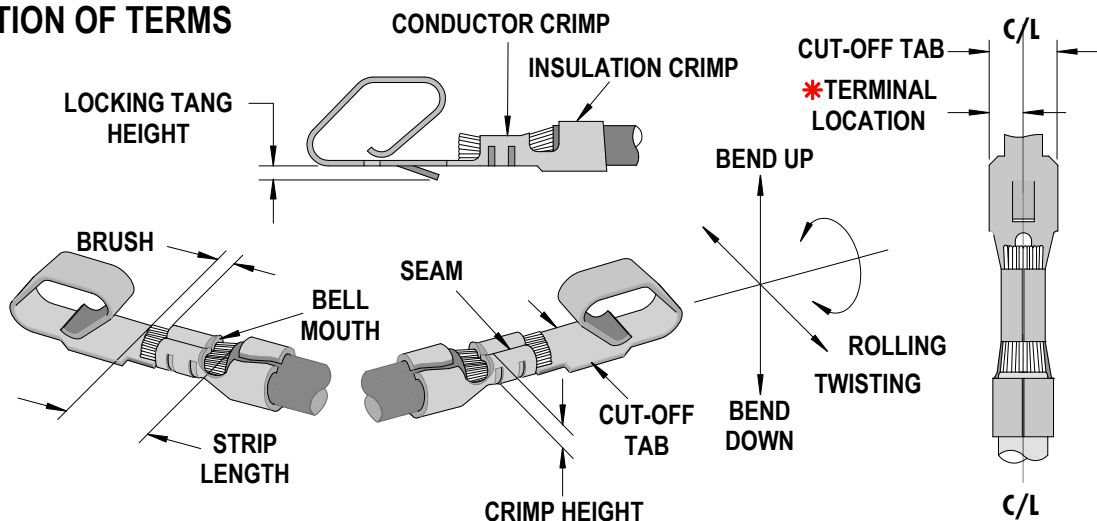

\* Terminal is to be centrally located between the two (2) cut-off tab edges by one half of the total cut-off tab tolerance.

This illustration is a generic terminal representation and not an exact image of any terminal listed in the scope.

## CRIMP SPECIFICATIONS

| Terminal Series No. | Bell mouth |     | *Cut-off Tab |           | Conductor Brush |     |
|---------------------|------------|-----|--------------|-----------|-----------------|-----|
|                     | mm         | In. | mm           | In.       | mm              | In. |
| 4809                |            |     | 1.85-1.98    | .073-.078 |                 |     |
| 8088                |            |     | 1.85-1.98    | .073-.078 |                 |     |

| Terminal Series No. | Locking Tang Height |      | Bend up | Bend down | Twist | Roll | Punch Width (Ref) |      |            |      | Seam<br><br>Seam shall not be open and no wire allowed out of the crimping area |
|---------------------|---------------------|------|---------|-----------|-------|------|-------------------|------|------------|------|---|
|                     | mm                  | In   | Degree  | Degree    | mm    | In   | Conductor         |      | Insulation |      |   |
|                     |                     |      |         |           |       |      | mm                | In   | mm         | In   |   |
| 4809                | 0.64                | .025 | 3       | 3         | 4     | 8    | 1.60              | .063 | 1.68       | .066 |   |
| 8088                | 0.64                | .025 | 3       | 3         | 4     | 8    | 1.60              | .063 | 1.68       | .066 |   |

**NOTE:** Some of the specifications in these charts above are intentionally left blank due to the fact that the information does not currently exist.

After crimping, the conductor profile should measure the following.

| Terminal Series No. | Wire Size |                 | Conductor    |           |                   |     | Pull Force Minimum |      |
|---------------------|-----------|-----------------|--------------|-----------|-------------------|-----|--------------------|------|
|                     | AWG       | mm <sup>2</sup> | Crimp Height |           | Crimp Width (Ref) |     | N                  | Lb.  |
|                     |           |                 | mm           | In.       | mm                | In. |                    |      |
| 4809                | 22        | 0.35            | 0.79-0.84    | .031-.033 |                   |     | 44.88              | 10.0 |
|                     | 24        | 0.20            | 0.74-0.79    | .029-.031 |                   |     | 35.59              | 8.0  |
|                     | 26        | 0.12            | 0.68-0.74    | .027-.029 |                   |     | 26.69              | 6.0  |
|                     | 28        | 0.08            | 0.66-0.71    | .026-.028 |                   |     | 17.79              | 4.0  |
|                     | 30        | 0.05            | 0.63-0.66    | .026-.027 |                   |     | 13.34              | 3.0  |
| 8088                | 22        | 0.35            | 0.79-0.84    | .031-.033 |                   |     | 44.88              | 10.0 |
|                     | 24        | 0.20            | 0.74-0.79    | .029-.031 |                   |     | 35.59              | 8.0  |
|                     | 26        | 0.12            | 0.68-0.74    | .027-.029 |                   |     | 26.69              | 6.0  |
|                     | 28        | 0.08            | 0.66-0.71    | .026-.028 |                   |     | 17.79              | 4.0  |
|                     | 30        | 0.05            | 0.63-0.66    | .026-.027 |                   |     | 13.34              | 3.0  |

### Tool Qualification Notes:

1. Pull Force should be measured with no influence from the insulation crimp.
2. The above specifications are guidelines to an optimum crimp.

**PARTS LIST**

| <b>Mini-Mac Applicator 63888-7000</b>  |                 |                        |                                |                 |
|--|-----------------|------------------------|--------------------------------|-----------------|
| <b>Item</b>  | <b>Order No</b> | <b>Engineering No.</b> | <b>Description</b>             | <b>Quantity</b> |
| <b>Perishable Tooling</b>  |                 |                        |                                |                 |
|  | 63888-7070      | 63888-7070             | Tool Kit (All "Y" Items)       | REF             |
| 1  | 11-18-4684      | 60756A101              | Conductor Punch                | 1 Y             |
| 2  | 11-18-4685      | 60756A102              | Conductor Anvil                | 1 Y             |
| 3  | 11-18-4686      | 60756A103              | Insulation Punch               | 1 Y             |
| 4  | 11-18-4687      | 60756A104              | Insulation Anvil               | 1 Y             |
| 5  | 11-18-4688      | 60756A105              | Cut-Off Insert                 | 1 Y             |
| 6  | 11-18-4689      | 60756A106              | Cut-off Punch                  | 1 Y             |
| <b>Other Components</b>  |                 |                        |                                |                 |
| 7  | 11-18-4003      | 60703-5                | Front Cover                    | 1               |
| 8  | 11-18-4348      | 60722A108              | Tooling Washer                 | 1               |
| 9  | 11-18-4469      | 60703-20               | Retainer Block                 | 1               |
| 10   | 11-18-4678      | 60756A111              | Wire Stop                      | 1               |
| 11   | 11-18-4754      | 60756A118              | Terminal Stop and Scrap Shield | 1               |
| 12   | 63803-5105      | 63803-5105             | Conductor Bushing              | 1               |
| 13   | 63820-0012      | 63820-0012             | Cover-Drag Frame               | 1               |
| 14   | 63888-7001      | 63888-7001             | Cover Plate                    | 1               |
| <b>Frame</b>   |                 |                        |                                |                 |
| 15   | 63801-3201      | 63801-3201             | Top                            | 1               |
| 16   | 63801-3283      | 63801-3283             | Base                           | 1               |
| 17   | 63443-6204      | 63443-6204             | Track                          | 1               |
| <b>Hardware</b>  |                 |                        |                                |                 |
| 18   | N/A             | N/A                    | M3 by 6 Long SHCS              | 2**             |
| 19   | N/A             | N/A                    | M3 by 8 Long SHCS              | 2**             |
| 20   | N/A             | N/A                    | M4 by 8 Long SHCS              | 2**             |
| 21   | N/A             | N/A                    | M4 by 12 Long BHCS             | 2**             |
| 22   | N/A             | N/A                    | M5 by 10 Long SHCS             | 1**             |
| 23   | N/A             | N/A                    | M8 by 20 Long BHCS             | 1**             |
| 24   | N/A             | N/A                    | #6-32 by 1/2" Long BHCS        | 2**             |
| 25   | N/A             | N/A                    | #10-32 by 1-1/4" Long SHCS     | 1**             |
| ** Available from an industrial supply company such as MSC (1-800-645-7270). |                 |                        |                                |                 |

### Assembly Drawing

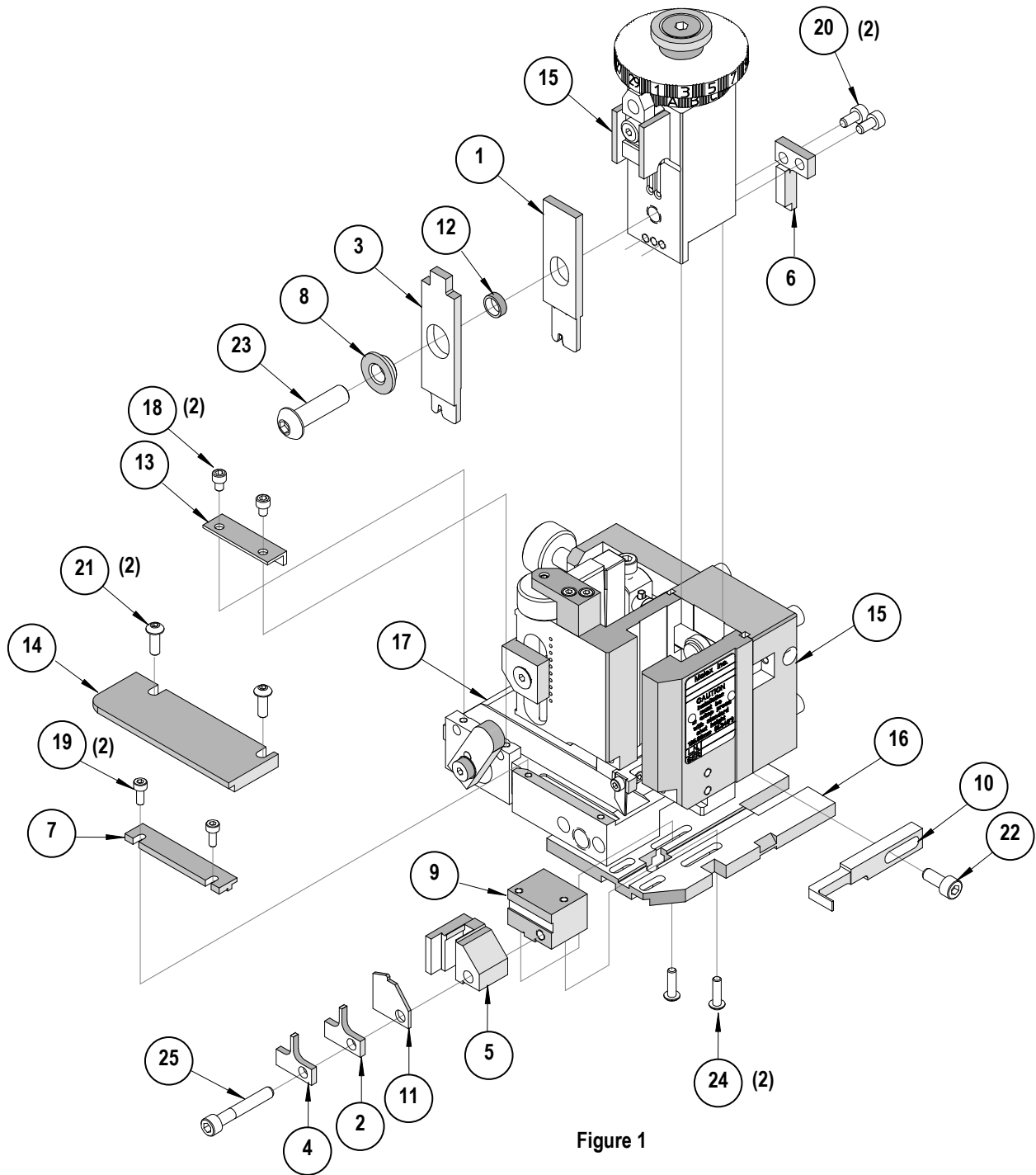

Figure 1

## NOTES

1. Molex recommends an extra perishable tooling kit be maintained at your facility.
2. Verify tooling alignment by manually cycling the press and Applicator before crimping under power. Check that all screws are tight.
3. Slugs, Terminals, Dirt and Oil should be kept clear of work area.
4. Wear safety glasses at all times.
5. For recommended maintenance refer to the Mini-Mac Manual.

**CAUTION:** This applicator should only be used in a press with a shut height of 135.8 mm (5.346"). Tooling damage could result at a lower setting.

**CAUTION:** To prevent injury never operate this Applicator without the guards supplied with the press or wire-processing machine in place. Reference the press or wire processing manufacturer's instruction manual.

**CAUTION:** Molex crimp specifications are valid only when used with Molex terminals, applicators and tooling.

<http://www.molex.com>