

PART NUMBER	REVISION	DESCRIPTION	FEED TYPE
2266026-1	C	FINE CRIMP HEIGHT ADJUST	MECHANICAL
2266026-2	C	FINE CRIMP HEIGHT ADJUST	PNEUMATIC
7-2266026-1	C	MECHANICAL AND CRIMP TOOLING KIT	MECHANICAL
7-2266026-2	C	PNEUMATIC AND CRIMP TOOLING KIT	PNEUMATIC
7-2266026-7	A	CRIMP TOOLING KIT	-

ATLANTIC VERSION TERMINATOR INTERFACE ADAPTER

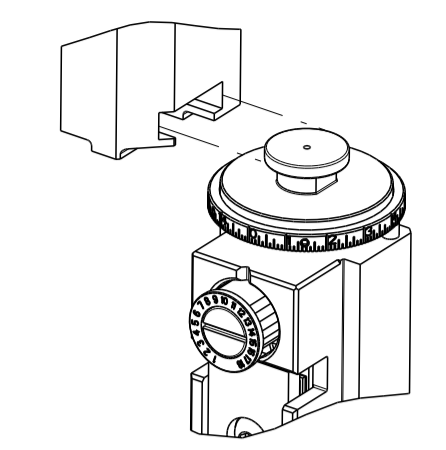

APPLICATOR DATA		
CRIMP	SIZE	TYPE
WIRE	1.40 mm [.055]	F
INSUL	1.40 mm [.055]	F

APPLICATOR INSTRUCTIONS
408-35042

TERMINAL DATA: SUMITOMO TERMINAL SUMITOMO CRIMP SPECIFICATION			
TERMINAL NAME: TERMINAL			
WIRE STRIP LENGTH	INSULATION DIAMETER RANGE	TERMINAL APPLICATION SPECIFICATION	TERMINALS APPLIED
4.00-4.50 mm [.157-.177 IN]	Ø1.00-1.50 mm [.039-.060 IN]	NONE	TE TERMINAL 2113372-1
			SUMITOMO TERMINAL 8100-4029

TERMINAL DATA: SUMITOMO TERMINAL SUMITOMO CRIMP SPECIFICATION			
TERMINAL NAME: TERMINAL			
WIRE STRIP LENGTH	INSULATION DIAMETER RANGE	TERMINAL APPLICATION SPECIFICATION	TERMINALS APPLIED
4.00-4.50mm [.157-.177 IN]	Ø1.00-1.50 mm [.039-.060 IN]	NONE	TE TERMINAL 1832368-2
			SUMITOMO TERMINAL 8100-4028

WIRE SIZE	CRIMP HEIGHT mm [INCH]	CRIMP HEIGHT REFERENCE SETTING
AVSS 0.30mm2	0.80+/-0.05 [.031+/- .002]	5.9
CHFUS 0.35mm2	0.75+/-0.05 [.030+/- .002]	6.5
CHFUS 0.22mm2	0.70+/-0.05 [.028+/- .002]	7.0

WIRE SIZE	CRIMP HEIGHT mm [INCH]	CRIMP HEIGHT REFERENCE SETTING
AVSS 0.30mm2	1.00+/-0.05 [.039+/- .002]	2.8
CHFUS 0.35mm2	0.95+/-0.05 [.037+/- .002]	3.4
CHFUS 0.22mm2	0.90+/-0.05 [.035+/- .002]	3.9

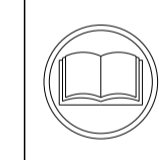

- RECOMMENDED SPARE PARTS
- REFER TO SUPPLIED INSTRUCTION SHEET FOR CLEANING, LUBRICATION AND STORAGE OF APPLICATOR.
- APPLY PART NUMBER 2-23419-6 LOCTITE TO THREADS OF ITEM 242.
- CRIMP HEIGHT REFERENCE SETTING WAS THE SETTING USED WHEN THE APPLICATOR WAS QUALIFIED AT THE FACTORY. ADJUSTMENT MAY BE NECESSARY WHEN RUNNING APPLICATOR IN THE FIELD.
- UNLESS SPECIFIED OTHERWISE TORQUE VALUES SHALL BE USED PER DOCUMENT, 101-35000.

***WARNING**
ON INSTALLATION, SET WIRE DISC TO CRIMP HEIGHT REFERENCE SETTING FOR LARGEST WIRE SIZE. CRIMP HEIGHT REFERENCE SETTINGS GREATER THAN THE VALUE SHOWN MAY CAUSE DAMAGE TO THE CRIMP TOOLING. REFER TO THE INSTRUCTION SHEET FOR PROPER SETUP AND ADJUSTMENTS.

LOC	DIST	REV	DATE	BY	CHKD	APPD
A	66	B	22DEC2015	MR	JDG	
		C	24MAR2019	TB	CT	

QTY	REF	REF	REF	REF	PART NO	DESCRIPTION	ITEM NO	
-	1	-	1	-	2119640-1	PUSH ROD, AIR FEED	250	
-	1	-	1	-	1803259-1	BUSHING, FLANGED	249	
-	1	-	1	-	2119641-1	FEED CAM, AIR FEED	248	
-	1	1	1	1	2119082-8	CAM, SNAIL, INSULATION ADJUSTMENT	244	
-	1	1	1	1	2079764-1	WASHER, WAVE SPRING, CREST-TO-CREST	243	
-	1	1	1	1	2119083-1	RETAINER, INSULATION DIAL	242	
-	1	1	1	1	7-18023-7	SCR, SKT HD CAP M3 X 4.0	241	
-	-	1	-	1	2119580-1	MECHANICAL FEED ASSEMBLY	239	
-	1	-	1	-	2063440-1	AIR FEED MODULE	238	
-	2	-	2	-	21045-3	RING, RETAIN, EXTERN, 3/16 CRESCENT	172	
-	REF	REF	REF	REF	994970-2	COUNTER, MAGNETIC	164	
-	1	-	1	-	240638-1	SPRING, FEED FINGER	163	
-	1	-	1	-	3-23627-7	PIN, RETAIN, GRVD, 3/16 X .854	137	
-	1	-	1	-	2119799-1	HOLDER, FEED FINGER, AF	136	
-	1	1	1	1	2844908-1	SCREW, LOCKING	99	
-	1	1	1	1	2844907-1	POST, LOCKING	98	
-	1	1	1	1	455888-4	SPACER, CRIMPER	82	
-	1	1	1	1	1803607-1	DOCUMENTATION PACKAGE	71	
-	1	1	1	1	2119791-9	DEPRESSOR, WIRE	70	
-	1	1	1	1	2119740-1	TAG, IDENTIFICATION	67	
-	2	2	2	2	2168078-1	SCREW, DRIVE, RH, RoHS, 2 x .188	66	
-	1	1	1	1	2168083-2	SCR, SKT HD CAP, RoHS, M4 X 8.0	60	
-	1	1	1	1	5-18022-5	SCR, HEX HD CAP, M4 X 6.0	59	
-	1	1	1	1	1338685-1	PAWL, FEED	56	
-	4	4	4	4	2168083-3	SCR, SKT HD CAP, RoHS, M4 X 12.0	54	
-	2	2	2	2	2168083-3	SCR, SKT HD CAP, RoHS, M4 X 12.0	53	
-	1	1	1	1	5018030-1	NUT, HEX, REG, RoHS, M3	52	
-	1	1	1	1	811242-5	BUMPER, HOLD DOWN	51	
-	1	1	1	1	690753-2	SPACER, TONKER	50	
-	1	2	1	2	18023-9	SCR, SKT HD CAP M4 X 6.0	49	
-	-	1	-	1	2119652-1	FEED CAM, PRE FEED	48	
-	-	1	-	1	2119653-1	FEED CAM, POST FEED	47	
-	1	1	1	1	1803583-9	APPLICATOR BASIC ASSEMBLY, SF	46	
-	1	1	1	1	1803515-1	RAM ASSEMBLY, SF ATLANTIC	44	
-	1	1	1	1	1803602-1	SCR, BHSC, RoHS (M8 X 25)	41	
-	1	1	1	1	1752356-3	SUPPORT, TERMINAL	34	
-	2	2	2	2	2079383-5	SCR, BHSC, RoHS (M4 X 20)	33	
-	2	2	2	2	2-2844962-4	SPACER, CYLINDRICAL, STRIP GUIDE	30	
-	1	1	1	1	2844992-1	ASSEMBLY, STRIP GUIDE	29	
-	1	1	1	1	1320928-2	STRIP GUIDE	24	
-	1	1	1	1	2168083-2	SCR, SKT HD CAP, RoHS, M4 X 8.0	21	
-	2	2	2	2	1-18028-2	WASHER, FLAT, REG M4	20	
-	1	1	1	1	2119533-1	STRIPPER, SIDE FEED	19	
-	1	1	1	1	2119806-1	INSERT, SHEAR	13	
-	1	1	1	1	3-22280-3	SPRING, COMPRESSION	12	
-	1	1	1	1	1-356885-4	STOP, SHEAR	11	
-	1	1	1	1	2119805-1	SHEAR HOLDER, FRONT	10	
-	1	1	1	1	1803095-6	FLOATING SHEAR, FRONT	9	
-	1	2	2	1	1	4-1633932-0	ANVIL, COMBINATION	8
-	1	1	1	1	240641-9	SPACER	7	
-	-	-	-	-	-	-	6	
-	1	1	1	1	2119757-5	DEPRESSOR, SHEAR	5	
-	1	1	1	1	238011-7	BLOCK, CRIMPER SPACER	4	
-	1	2	2	1	1	1-1633961-2	CRIMPER, INSULATION F PREMIUM	3
-	1	1	1	1	455888-4	SPACER, CRIMPER	2	
-	1	2	2	1	1	1-456402-8	CRIMPER, WIRE PREMIUM	1

ATLANTIC VERSION
Shown on sheets 1 of 4 & 2 of 4
(Pacific version shown on sheets 3 of 4 & 4 of 4)

DIMENSIONS:		TOLERANCES UNLESS OTHERWISE SPECIFIED:		MATERIAL:		FINISH:	
mm	0 PLC ±	1 PLC ±	2 PLC ±	3 PLC ±	4 PLC ±	ANGLES ±	FINISH ±

OWN	C. CHEN	26AUG2013
CHK	U. GUO	26AUG2013
APPD	J. CRUZ	26AUG2013
PRODUCT SPEC		
APPLICATION SPEC		
SIZE	A1	00779
CAGE CODE	C=2266026	
DRAWING NO	00779	
RESTRICTED TO		
WEIGHT		
SCALE	1:2	
SHEET	1 of 4	
REV	C	

LOC		DIST		REVISIONS			
P	LTN	DESCRIPTION	DATE	DWN	APVD		
-	-	SEE SHEET 1	-	-	-		

FEED TYPE MECHANICAL



PNEUMATIC

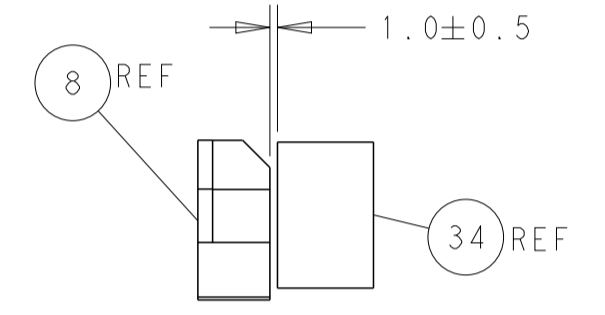
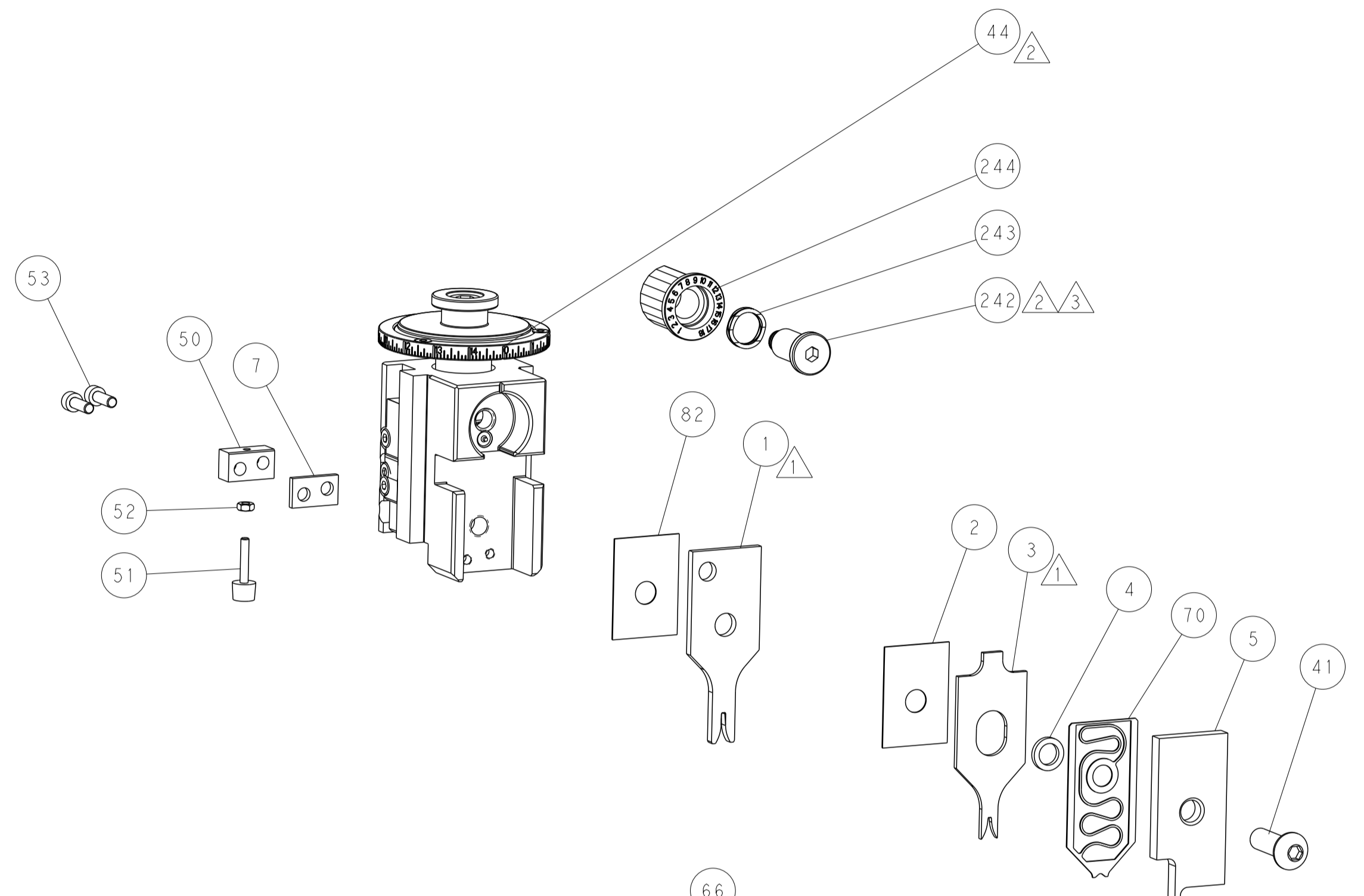
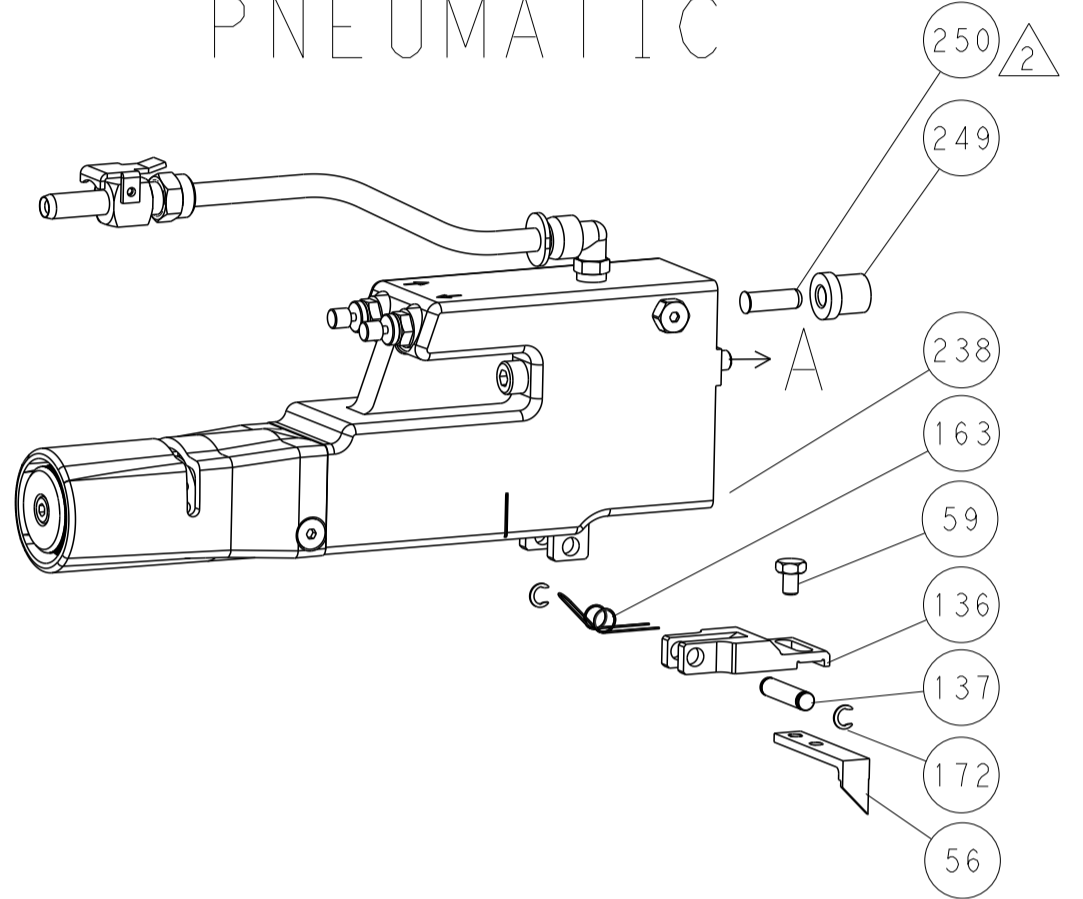

TERMINAL SUPPORT LOCATION

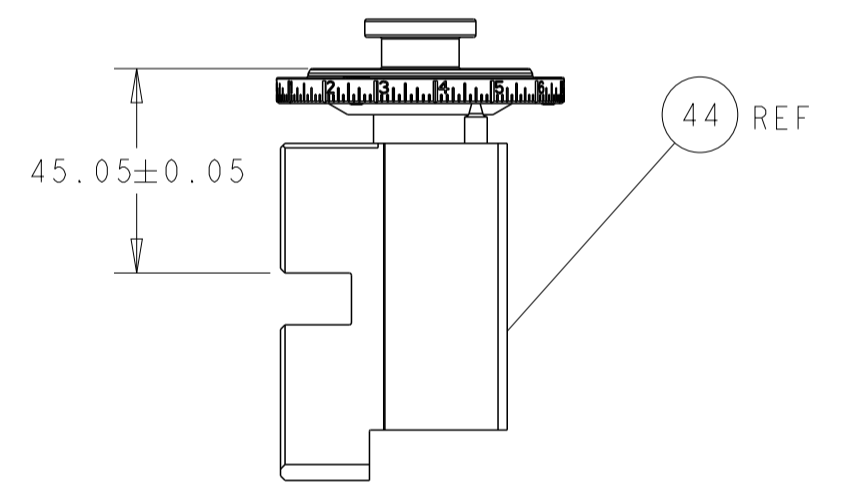

RAM SET-UP

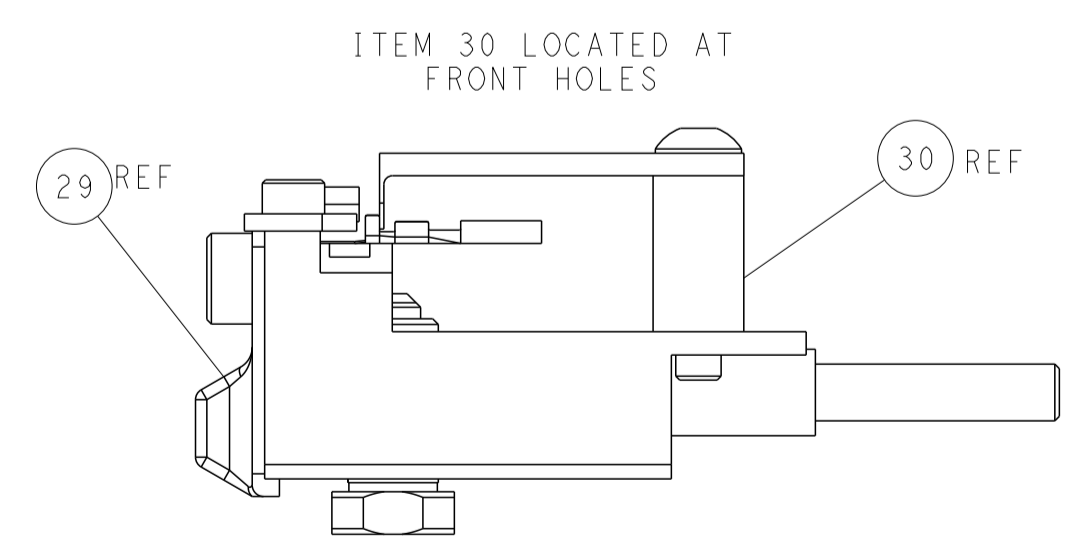
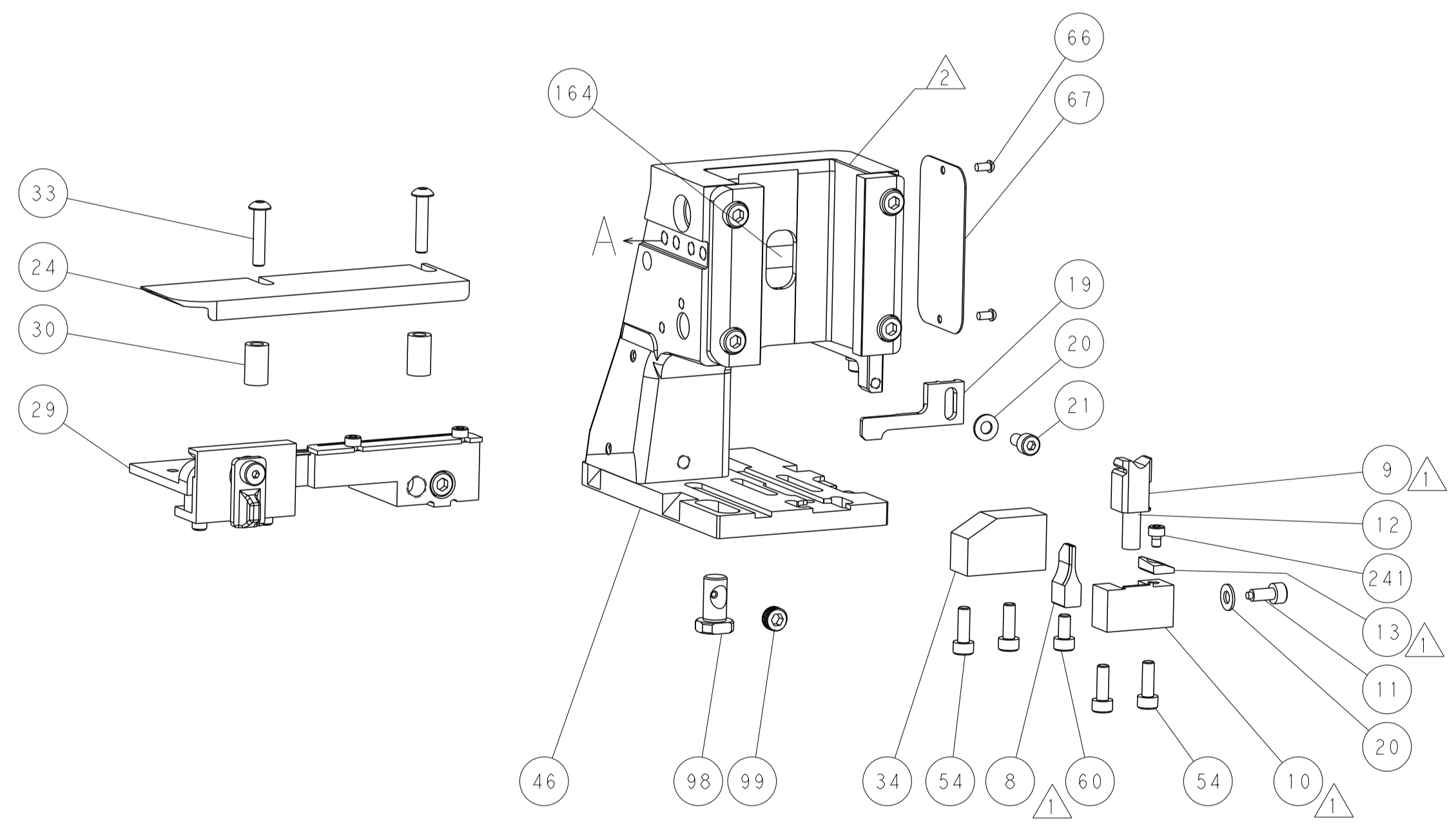

FEED TRACK POSITION
GUIDE BY INSULATION BARREL

CAM POSITIONS

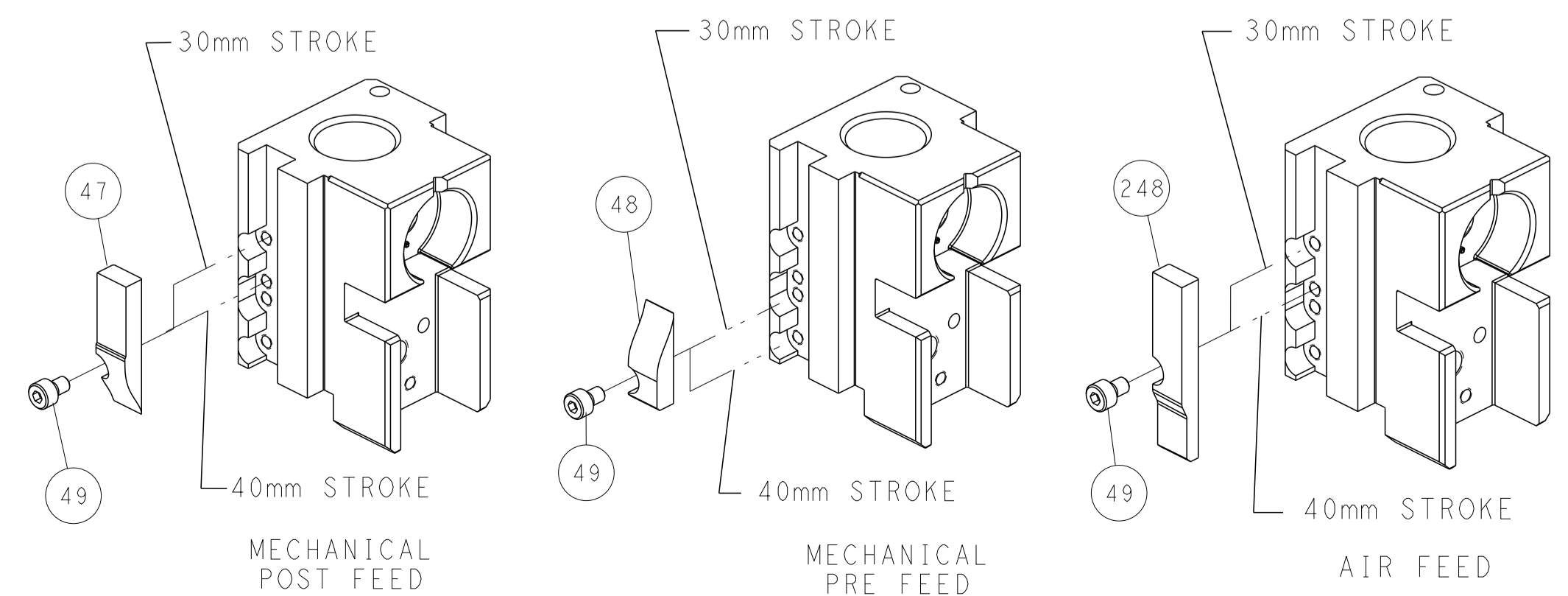

ATLANTIC VERSION
 Shown on sheets 1 of 4 & 2 of 4
 (Pacific version shown on sheets 3 of 4 & 4 of 4)

DIMENSIONS:		TOLERANCES UNLESS OTHERWISE SPECIFIED:		DWN C. CHEN 26AUG2013		CHK U. GUO 26AUG2013		NAME Ocean Side Feed Applicator	
mm	0 PLC ±	1 PLC ±	2 PLC ±	3 PLC ±	4 PLC ±	APVD J. CRUZ 26AUG2013	PRODUCT SPEC	APPLICATION SPEC	SIZE CAGE CODE DRAWING NO
	ANGLES ±	FINISH ±				WEIGHT	A1 00779	©=2266026	RESTRICTED TO
MATERIAL						Customer Accessible Production Drawing	SCALE 1:2	SHEET 2 of 4	REV C

PART NUMBER	REVISION	DESCRIPTION	FEED TYPE
2-2266026-1	C	FINE CRIMP HEIGHT ADJUST	MECHANICAL
2-2266026-2	C	FINE CRIMP HEIGHT ADJUST	PNEUMATIC
7-2266026-7	A	CRIMP TOOLING KIT	-

PACIFIC VERSION TERMINATOR
INTERFACE ADAPTER



APPLICATOR DATA		
CRIMP	SIZE	TYPE
WIRE	1.40 mm [.055]	F
INSUL	1.40 mm [.055]	F
APPLICATOR INSTRUCTIONS 408-35042		

TERMINAL DATA: SUMITOMO TERMINAL SUMITOMO CRIMP SPECIFICATION			
TERMINAL NAME: TERMINAL			
WIRE STRIP LENGTH 4.00-4.50 mm [.157-.177 IN]		INSULATION DIAMETER RANGE Ø1.00-1.50 mm [.039-.060 IN]	
TERMINAL APPLICATION SPECIFICATION	NONE	-	-
TERMINALS APPLIED			
TE TERMINAL	SUMITOMO TERMINAL	TE TERMINAL	SUMITOMO TERMINAL
2113372-1	8100-4029		

TERMINAL DATA: SUMITOMO TERMINAL SUMITOMO CRIMP SPECIFICATION			
TERMINAL NAME: TERMINAL			
WIRE STRIP LENGTH 4.00-4.50mm [.157-.177 IN]		INSULATION DIAMETER RANGE Ø1.00-1.50 mm [.039-.060 IN]	
TERMINAL APPLICATION SPECIFICATION	NONE	-	-
TERMINALS APPLIED			
TE TERMINAL	SUMITOMO TERMINAL	TE TERMINAL	SUMITOMO TERMINAL
1832368-2	8100-4028		

WIRE SIZE	CRIMP HEIGHT mm [INCH]	CRIMP HEIGHT REFERENCE SETTING
AVSS 0.30mm2	0.80 +/- 0.05 [.031 +/- .002]	5.9
CHFUS 0.35mm2	0.75 +/- 0.05 [.030 +/- .002]	6.5
CHFUS 0.22mm2	0.70 +/- 0.05 [.028 +/- .002]	7.0

WIRE SIZE	CRIMP HEIGHT mm [INCH]	CRIMP HEIGHT REFERENCE SETTING
AVSS 0.30mm2	1.00 +/- 0.05 [.039 +/- .002]	2.8
CHFUS 0.35mm2	0.95 +/- 0.05 [.037 +/- .002]	3.4
CHFUS 0.22mm2	0.90 +/- 0.05 [.035 +/- .002]	3.9

- ⚠ RECOMMENDED SPARE PARTS
- ⚠ REFER TO SUPPLIED INSTRUCTION SHEET FOR CLEANING, LUBRICATION AND STORAGE OF APPLICATOR.
- ⚠ APPLY PART NUMBER 2-23419-6 LOCTITE TO THREADS OF ITEM 242.
- ⚠ CRIMP HEIGHT REFERENCE SETTING WAS THE SETTING USED WHEN THE APPLICATOR WAS QUALIFIED AT THE FACTORY. ADJUSTMENT MAY BE NECESSARY WHEN RUNNING APPLICATOR IN THE FIELD.
- 5. UNLESS SPECIFIED OTHERWISE TORQUE VALUES SHALL BE USED PER DOCUMENT, 101-35000.

***WARNING**
ON INSTALLATION, SET WIRE DISC TO CRIMP HEIGHT REFERENCE SETTING FOR LARGEST WIRE SIZE. CRIMP HEIGHT REFERENCE SETTINGS GREATER THAN THE VALUE SHOWN MAY CAUSE DAMAGE TO THE CRIMP TOOLING. REFER TO THE INSTRUCTION SHEET FOR PROPER SETUP AND ADJUSTMENTS.

LOC	DIST	REV	DATE	BY	APPV
-	-	1	-	-	-

REV	DATE	BY	APPV	DESCRIPTION	ITEM NO	
-	1	-	-	2119640-1	PUSH ROD, AIR FEED	250
-	1	-	-	1803259-1	BUSHING, FLANGED	249
-	1	1	-	2119082-8	CAM, SNAIL, INSULATION ADJUSTMENT	244
-	1	1	-	2079764-1	WASHER, WAVE SPRING, CREST-TO-CREST	243
-	1	1	-	2119083-1	RETAINER, INSULATION DIAL	242
-	1	1	-	7-18023-7	SCR, SKT HD CAP M3 X 4.0	241
-	2	-	-	2119580-1	MECHANICAL FEED ASSEMBLY	239
-	1	-	-	2063440-1	AIR FEED MODULE	238
-	2	-	-	21045-3	RING, RETAIN, EXTERN, 3/16 CRESCENT	172
-	REF	REF	-	994970-2	COUNTER, MAGNETIC	164
-	1	-	-	240638-1	SPRING, FEED FINGER	163
-	1	-	-	2119641-2	FEED CAM, AIR FEED	151
-	1	1	-	2168083-8	SCR, SKT HD CAP, RoHS, M4 X 16	144
-	4	4	-	2168083-9	SCR, SKT HD CAP, RoHS, M4 X 20	143
-	-	1	-	2119653-2	FEED CAM, POST FEED	142
-	1	1	-	1-1803583-0	APPLICATOR BASIC ASSEMBLY, SF	141
-	1	1	-	1803516-1	RAM ASSEMBLY, SF PACIFIC	140
-	1	-	-	3-23627-7	PIN, RETAIN, GRVD, 3/16 X .854	137
-	1	-	-	2119799-1	HOLDER, FEED FINGER, AF	136
-	1	1	-	2844908-1	SCREW, LOCKING	99
-	1	1	-	2844907-1	POST, LOCKING	98
-	1	1	-	455888-4	SPACER, CRIMPER	82
-	1	1	-	1803607-1	DOCUMENTATION PACKAGE	71
-	1	1	-	2119791-9	DEPRESSOR, WIRE	70
-	1	1	-	2119740-1	TAG, IDENTIFICATION	67
-	2	2	-	2168078-1	SCREW, DRIVE, RH, RoHS, 2 x .188	66
-	1	1	-	5-18022-5	SCR, HEX HD CAP, M4 X 6.0	59
-	1	1	-	1338685-1	PAWL, FEED	56
-	2	2	-	2168083-3	SCR, SKT HD CAP, RoHS, M4 X 12.0	53
-	1	1	-	5018030-1	NUT, HEX, REG, RoHS, M3	52
-	1	1	-	811242-5	BUMPER, HOLD DOWN	51
-	1	1	-	690753-2	SPACER, TONKER	50
-	1	2	-	18023-9	SCR, SKT HD CAP M4 X 6.0	49
-	-	1	-	2119652-1	FEED CAM, PRE FEED	48
-	1	1	-	1803602-1	SCR, BHSC, RoHS (M8 X 25)	41
-	1	1	-	1752356-3	SUPPORT, TERMINAL	34
-	2	2	-	2079383-5	SCR, BHSC, RoHS (M4 X 20)	33
-	2	2	-	2-2844962-4	SPACER, CYLINDRICAL, STRIP GUIDE	30
-	1	1	-	2844992-1	ASSEMBLY, STRIP GUIDE	29
-	1	1	-	1320928-2	STRIP GUIDE	24
-	1	1	-	2168083-2	SCR, SKT HD CAP, RoHS, M4 X 8.0	21
-	2	2	-	1-18028-2	WASHER, FLAT, REG M4	20
-	1	1	-	2119533-1	STRIPPER, SIDE FEED	19
-	1	1	-	2119806-1	INSERT, SHEAR	13
-	1	1	-	3-22280-3	SPRING, COMPRESSION	12
-	1	1	-	1-356885-4	STOP, SHEAR	11
-	1	1	-	2119805-1	SHEAR HOLDER, FRONT	10
-	1	1	-	1803095-6	FLOATING SHEAR, FRONT	9
-	1	1	1	4-1633932-0	ANVIL, COMBINATION	8
-	1	1	-	240641-9	SPACER	7
-	-	-	-	-	-	6
-	1	1	-	2119757-5	DEPRESSOR, SHEAR	5
-	1	1	-	238011-7	BLOCK, CRIMPER SPACER	4
-	1	1	1	1-1633961-2	CRIMPER, INSULATION F PREMIUM	3
-	1	1	-	455888-4	SPACER, CRIMPER	2
-	1	1	1	1-456402-8	CRIMPER, WIRE PREMIUM	1

PACIFIC VERSION
Shown on sheets 3 of 4 & 4 of 4
(Atlantic version shown on sheets 1 of 4 & 2 of 4)

DIMENSIONS: mm		TOLERANCES UNLESS OTHERWISE SPECIFIED:		DWG C. CHEN 26AUG2013	
0 PLC	±	0.15	±	CHK U. GUO 26AUG2013	
1 PLC	±	0.25	±	APPV I. CRUZ 26AUG2013	
2 PLC	±	0.38	±	NAME Ocean Side Feed Applicator	
3 PLC	±	0.51	±	PRODUCT SPEC	
4 PLC	±	0.64	±	APPLICATION SPEC	
ANGLES	±		±	SIZE CAGE CODE DRAWING NO	
FINISH	±		±	RESTRICTED TO	
MATERIAL		FINISH		WEIGHT	
				A1 00779 C=2266026	
Customer Accessible Production Drawing				SCALE 1:2 SHEET 3 OF 4 REV C	

LOC	DIST	REV	DESCRIPTION	DATE	DWN	APVD
		-	SEE SHEET 1			

FEED TYPE MECHANICAL

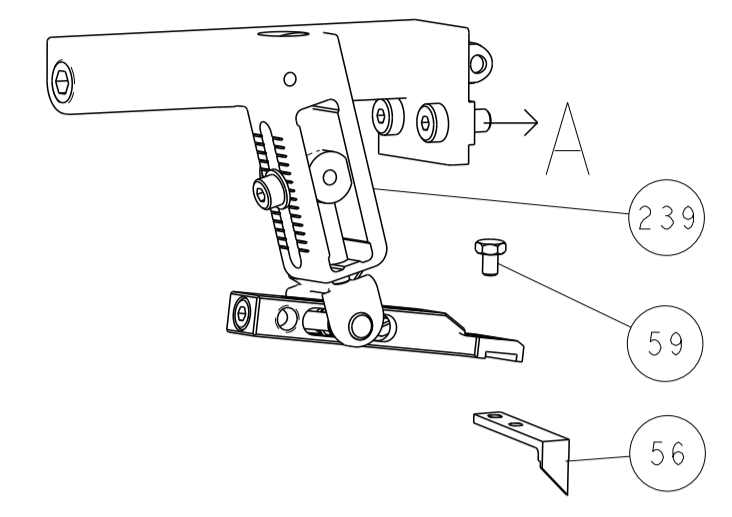

PNEUMATIC

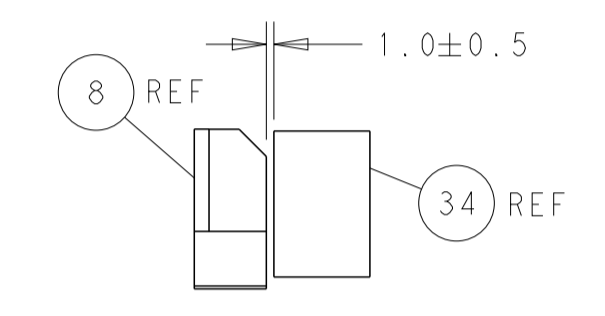
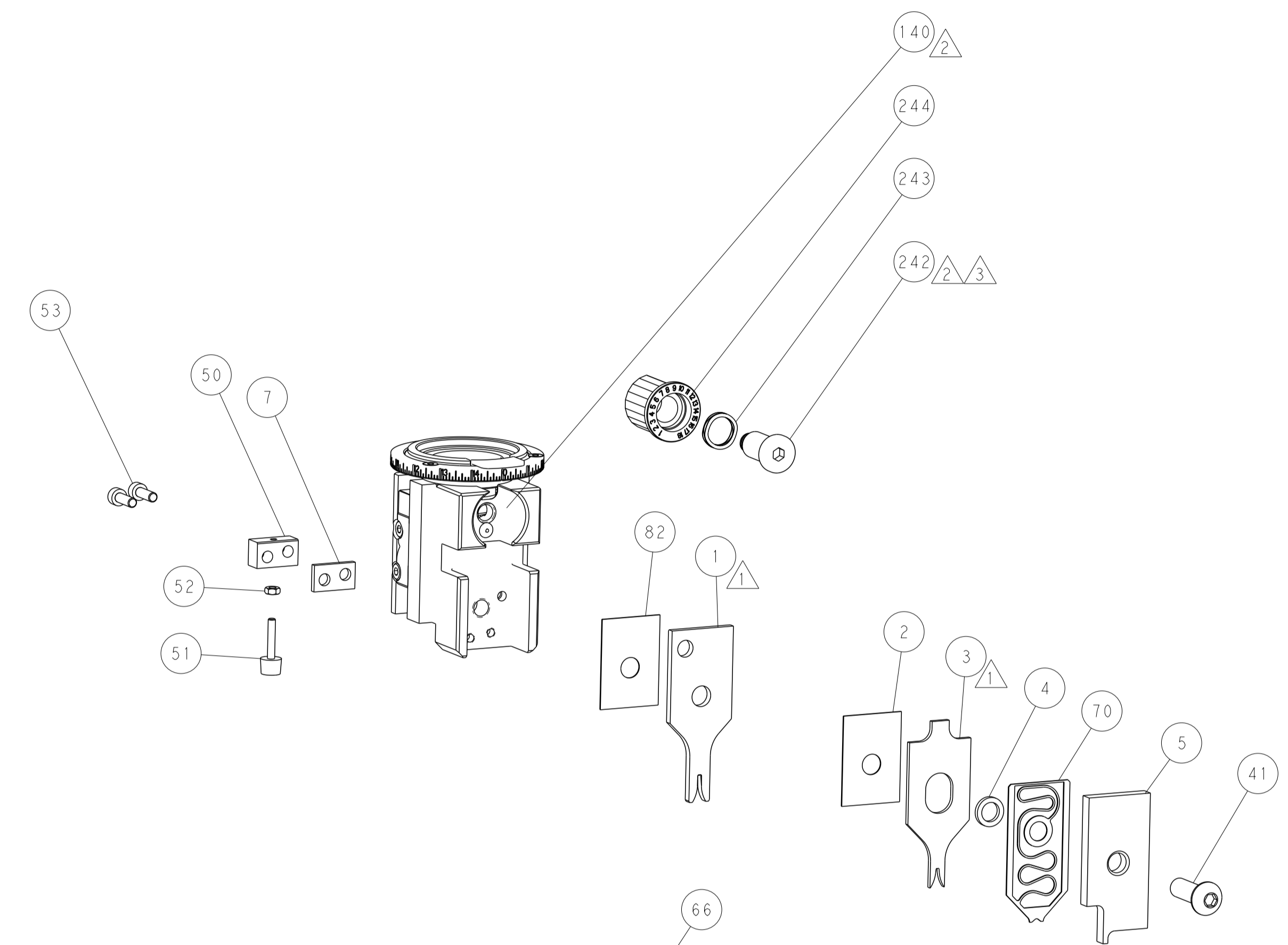
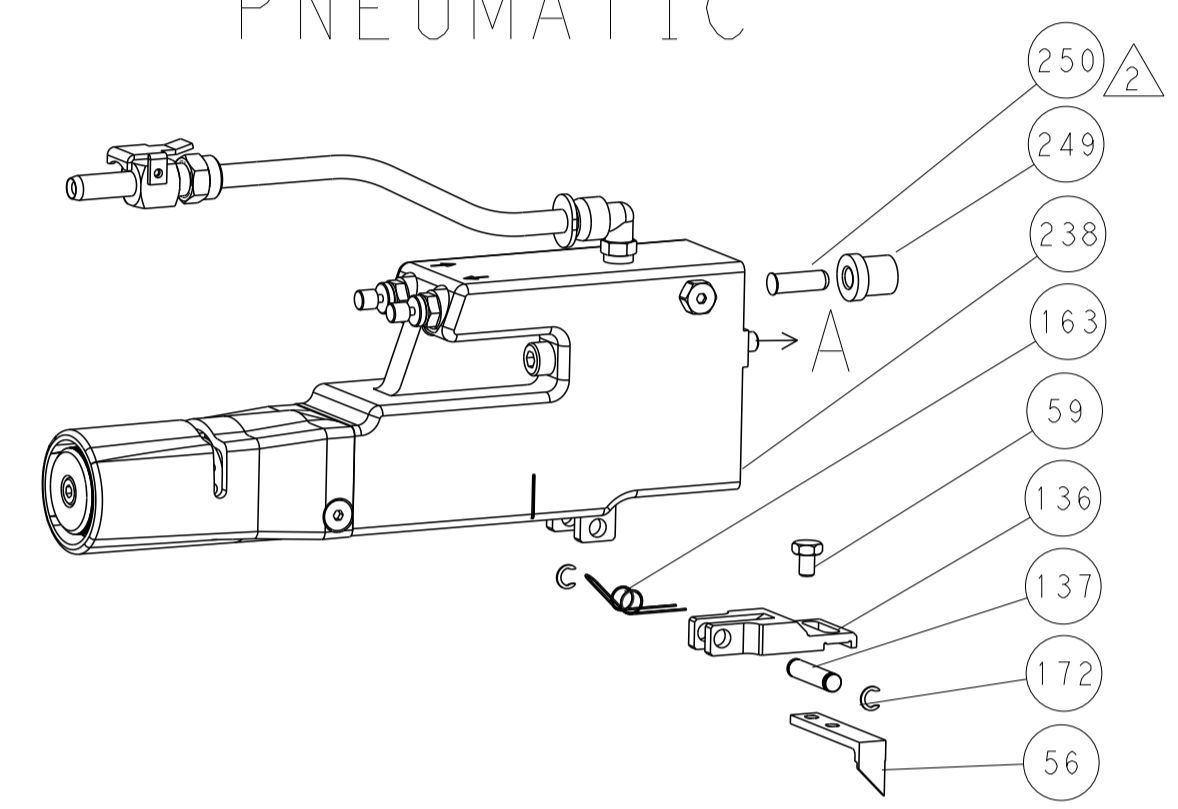

TERMINAL SUPPORT LOCATION

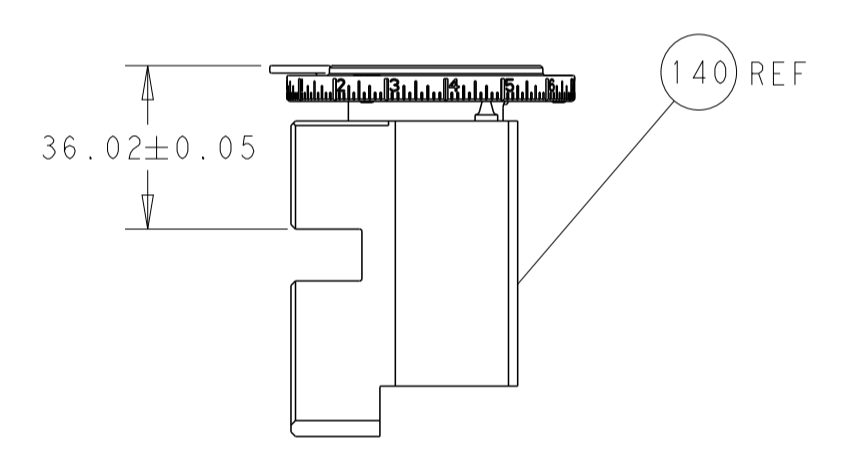

RAM SET-UP

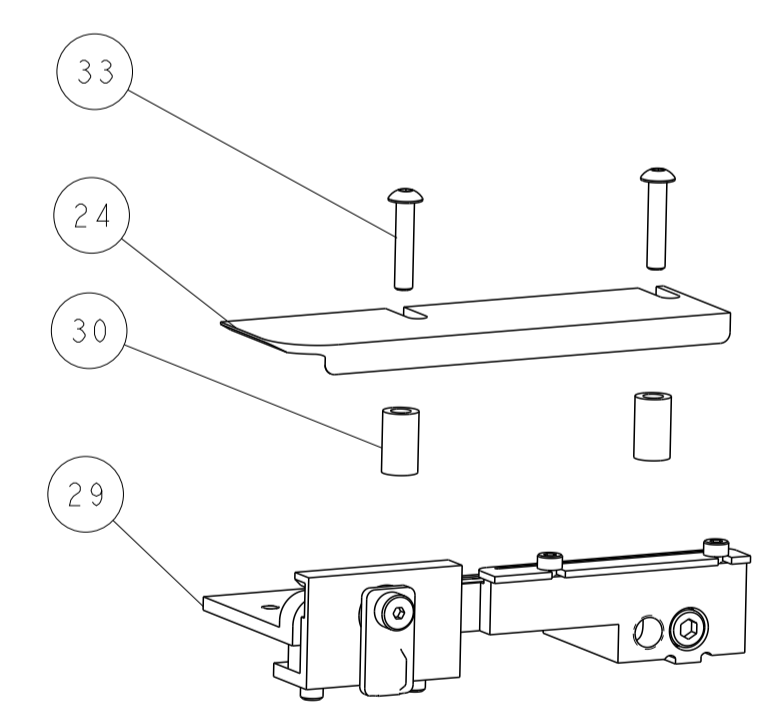

CAM POSITIONS

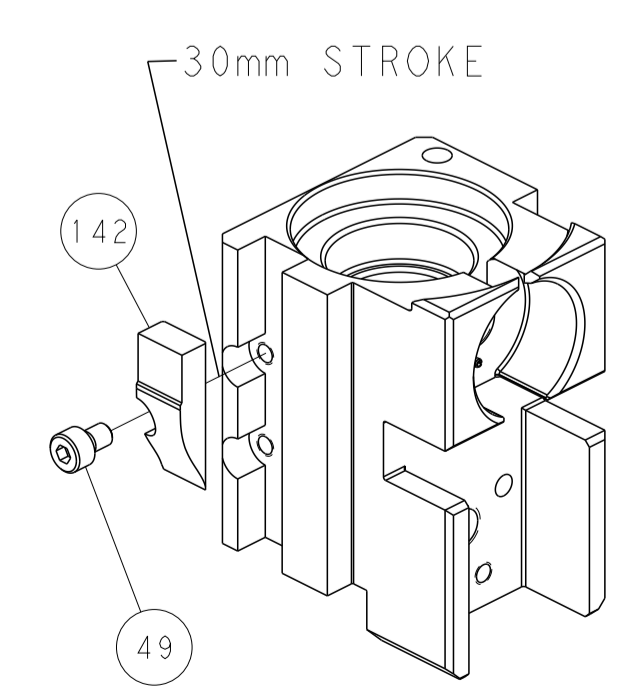

MECHANICAL POST FEED

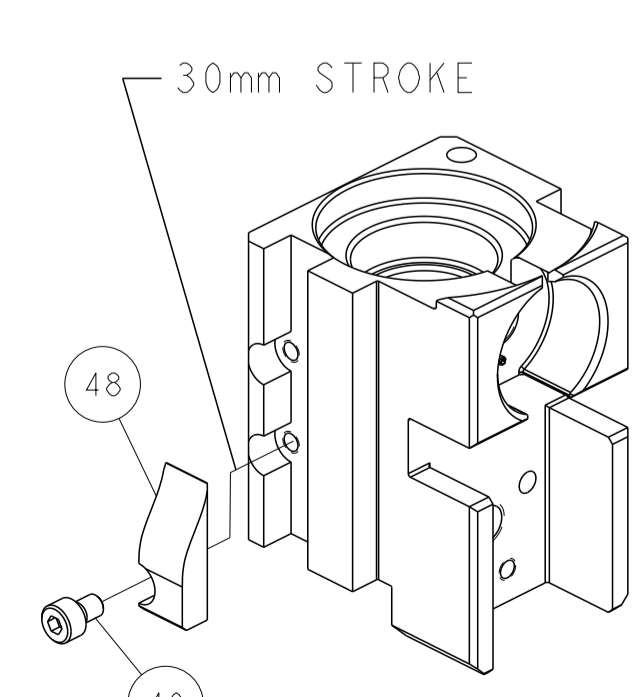

MECHANICAL PRE FEED

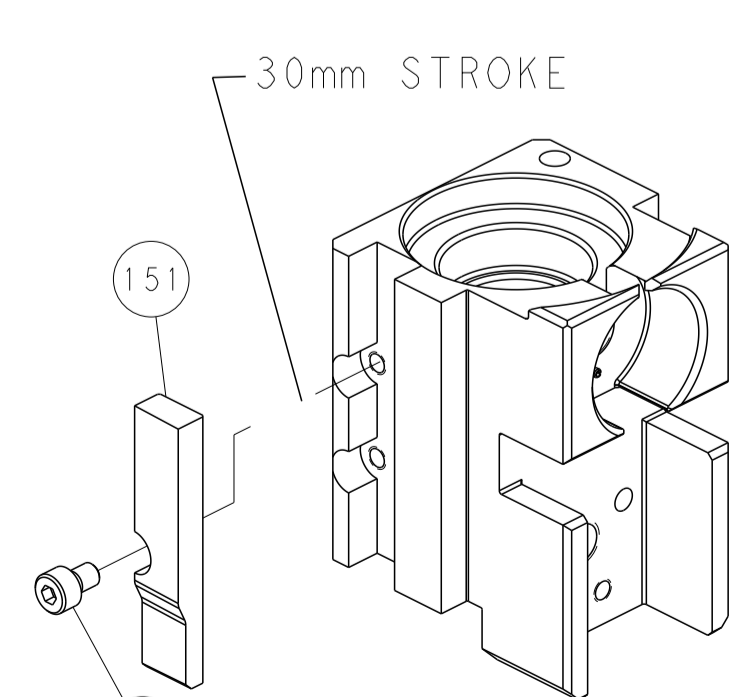

AIR FEED

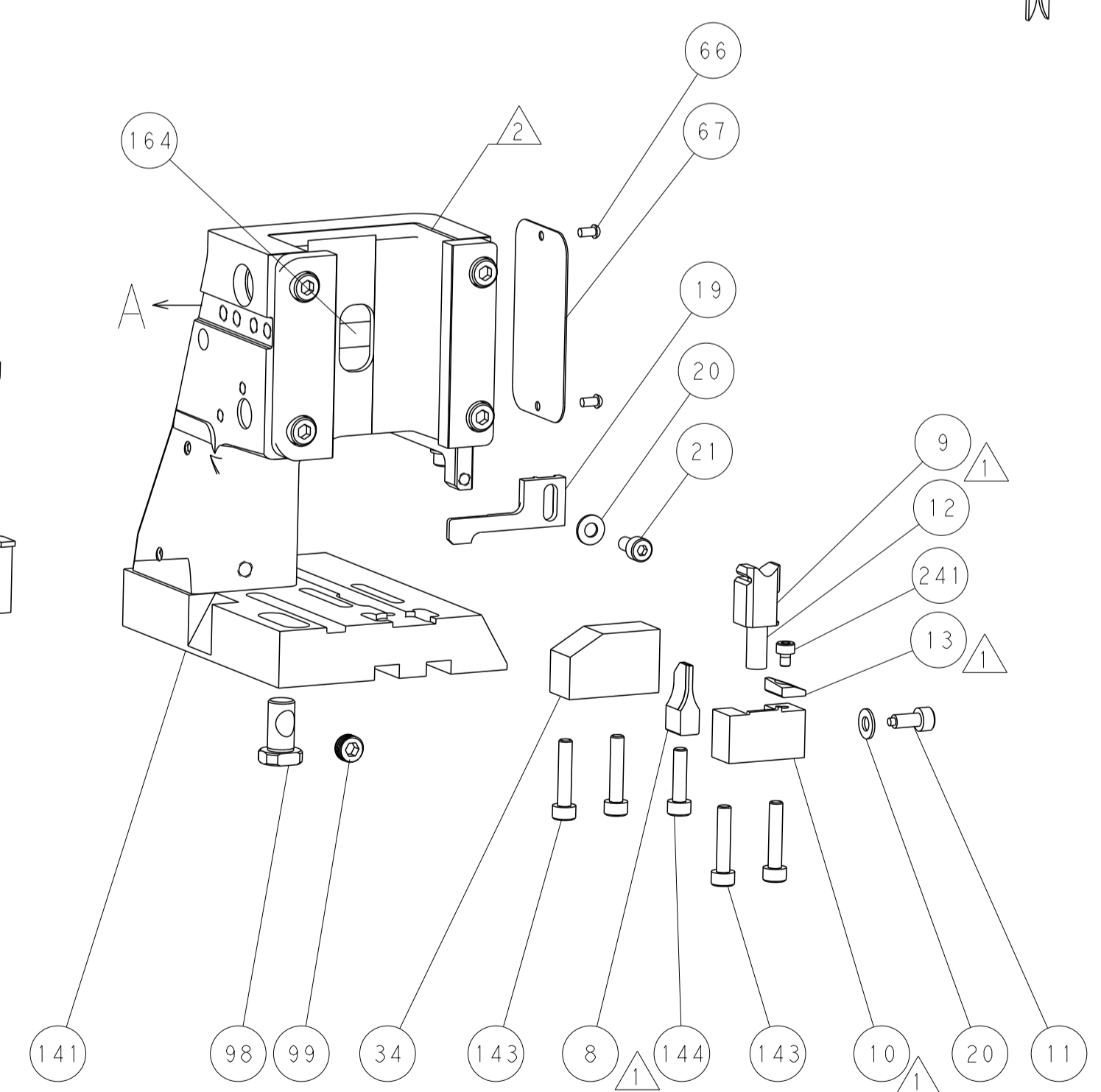

ITEM 30 LOCATED AT FRONT HOLES

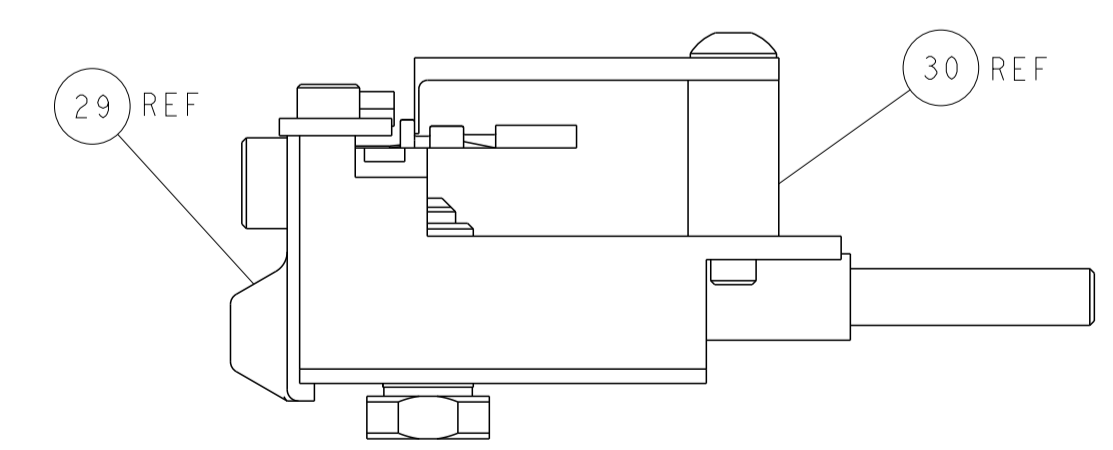

FEED TRACK POSITION GUIDE BY INSULATION BARREL

PACIFIC VERSION
 Shown on sheets 3 of 4 & 4 of 4
 (Atlantic version shown on sheets 1 of 4 & 2 of 4)

<small>THIS DRAWING IS UNPUBLISHED. RELEASED FOR PUBLICATION. IT IS THE PROPERTY OF TYCO ELECTRONICS CORPORATION. IT IS TO BE USED ONLY FOR THE PURPOSES AND IN THE QUANTITIES SPECIFIED IN THE ORDER. IT IS TO BE RETURNED TO TYCO ELECTRONICS CORPORATION IF NOT SO USED.</small>		DWN: C. CHEN 26AUG2013 CHK: U. GUO 26AUG2013 APVD: J. CRUZ 26AUG2013	
DIMENSIONS: mm TOLERANCES UNLESS OTHERWISE SPECIFIED: 0 PLC ± 1 PLC ± 2 PLC ± 3 PLC ± 4 PLC ± ANGLES ± FINISH ±		NAME: Ocean Side Feed Applicator PRODUCT SPEC: APPLICATION SPEC: SIZE: CAGE CODE: DRAWING NO: A1 00779 ©=2266026 WEIGHT:	RESTRICTED TO:
MATERIAL:		CUSTOMER ACCESSIBLE PRODUCTION DRAWING	SCALE: 1:2 SHEET 4 OF 4 REV C