

- NOTES
- The dimension in parentheses are for reference.
 - Lead co-planarity including reinforced chucking metals shall be 0.1 max.
 - To be delivered with tape and reel packages. see attached packaging specifications for details.
 - Note that preventive hole for sink mark or slit could be added for improvement.
 - The quality remains good, even with the dark spots, which could occasionally occur on molded plastic.
 - This product satisfies halogen free requirements defined as 900ppm maximum chlorine, 900ppm maximum bromine, and 1500ppm maximum total of chlorine and bromine.
 - Shows hook part of the chucking metal.

4	PHOSPHOR BRONZE	(CONTACT AREA LEAD) GOLD PLATING 0.03µm MIN OVER NICKEL 1µm MIN. (OTHER) NICKEL PLATING 1µm MIN.	9	(CONNECTOR)				
3	PHOSPHOR BRONZE	(CONTACT AREA LEAD) GOLD PLATING 0.03µm MIN OVER NICKEL 1µm MIN. (OTHER) NICKEL PLATING 1µm MIN.	8	POLYSTYRENE				
2	PA	BLACK UL94HB	7	POLYESTER				
1	LCP	BEIGE UL94V-0	6	POLYSTYRENE				
			5	PHOSPHOR BRONZE (PLATED MATERIAL)	TIN PLATING (REFLOW FINISHED) 1µm MIN.			
NO.	MATERIAL	FINISH . REMARKS	NO.	MATERIAL	FINISH . REMARKS			
UNITS	mm	SCALE	10 : 1	COUNT	DESCRIPTION OF REVISIONS	DESIGNED	CHECKED	DATE
APPROVED : MO. ISHIDA		13.04.12		DRAWING NO.		EDC3-336359-00		
CHECKED : ST. WADA		13.04.12		PART NO.		FH53-41S-0.2SHW		
DESIGNED : HY. YAMAZAKI		13.04.12		CODE NO.		CL580-3401-7-00		
DRAWN : HY. YAMAZAKI		13.04.12				1/7		

RECOMMENDED FPC (20:1)

(Exposed conductor area thickness: $t=0.12\pm 0.02$)

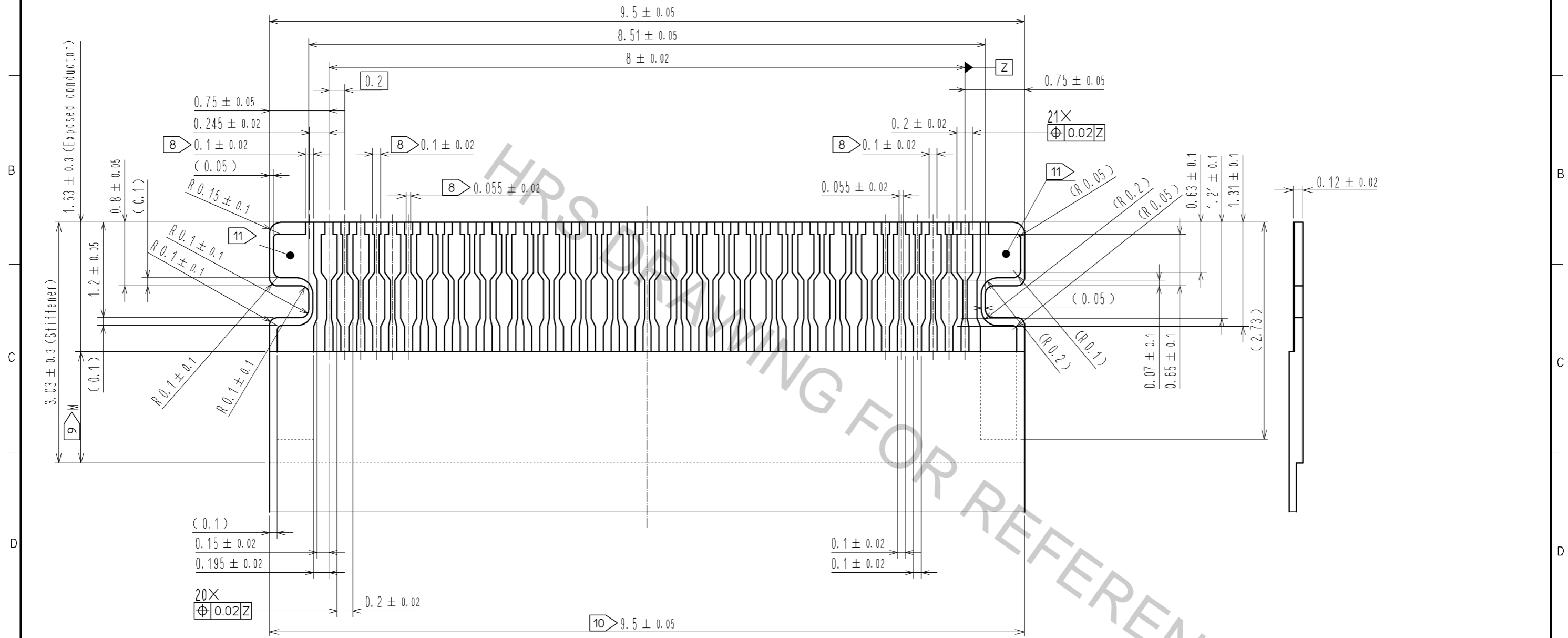

FPC CONSTRUCTION Recommended Specifications (FREE)

MATERIAL NAME	MATERIAL	THICKNESS(μm)
Covering film layer.	Polyimide 1mil	25
Cover adhesive		25
Surface treatment	1μm to 6μm nickel underplated 0.2μm gold plated	(4)
Copper foil	Cu 1/3 oz	12
Base adhesive	Heat-hardened adhesive	No adhesion material
Base film	Polyimide 1mil	25
Reinforcement material adhesive	Heat-hardened adhesive	30
Stiffener	Polyimide 2mil	50

- NOTES
- 8 Shows recommended dimension when lead for plating is required.
 - 9 Dimension M must be 1mm minimum.
 - 10 Indicated tolerance is applicable to the exposed conductor.
 - 11 Both end side of contact pad on FPC can not be used for signal transmission.

<RECOMMENDED FPC>

HRS	DRAWING NO.	EDC3-336359-00
	PART NO.	FH53-41S-0.2SHW
	CODE NO.	CL580-3401-7-00
		△ 2/7

EMBOSSED CARRIER TAPE DIMENSION (5:1)

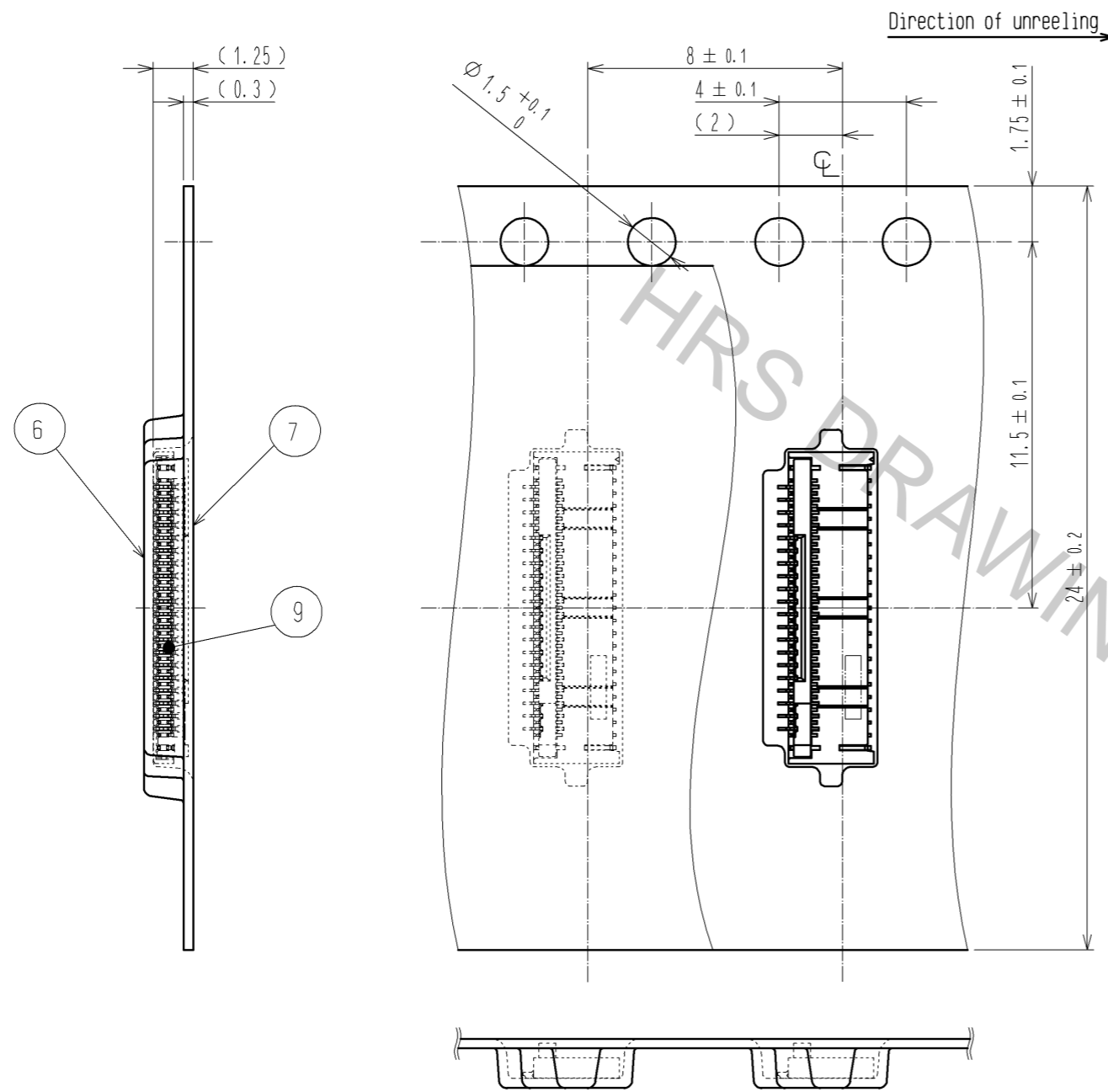

REEL DIMENSION (FREE)

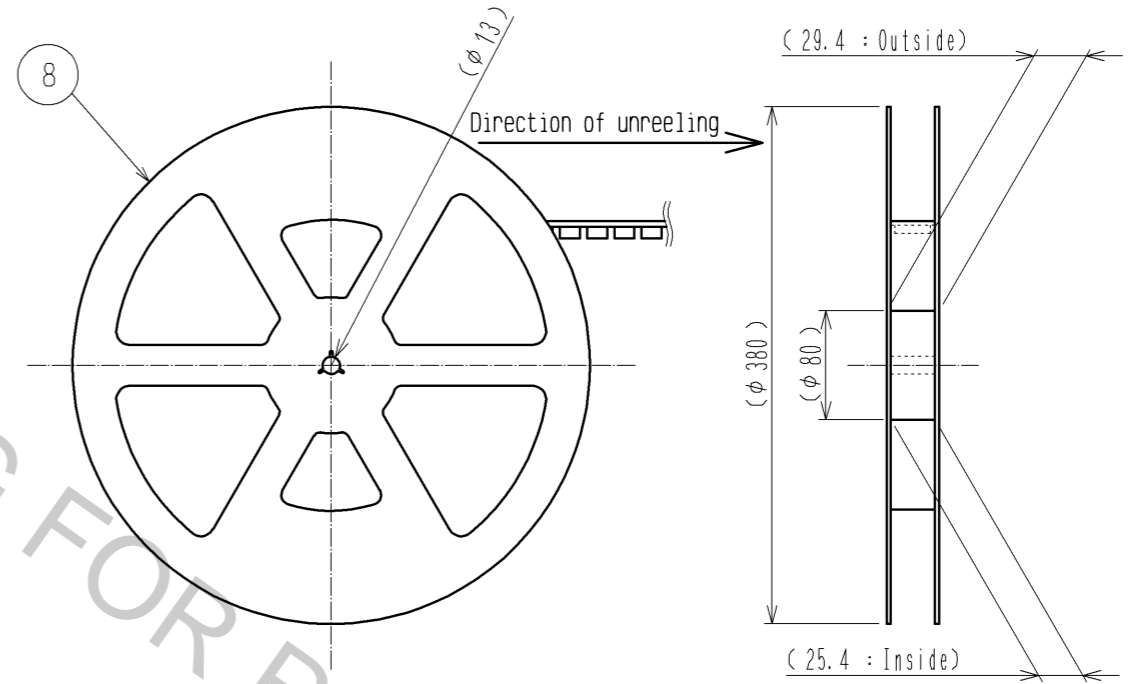

- Notes
 12. Per reel : 5000 connectors.
 13. Refer to JIS C 0806 (Packaging of components for automatic handling.)

LEADER, TRAILER DIMENSION (FREE)

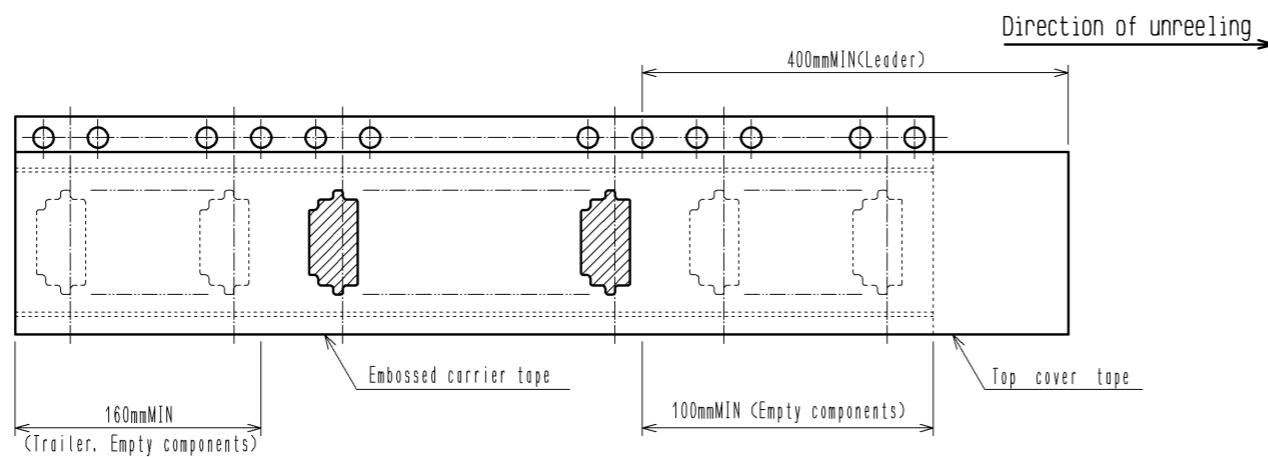

<PACKING SPECIFICATIONS>

HRS	DRAWING NO.	EDC3-336359-00
	PART NO.	FH53-41S-0.2SHW
	CODE NO.	CL580-3401-7-00
		△ 3/7

This connector features small, thin and back flip design, requiring delicate and careful handling. To prevent connector/FPC breakage and contact failure (mating failure, FPC pattern breakage, etc), read through the instructions shown below and handle the connector properly. Each values indicating here are for reference and may differ from standard value.

[Operation and Precautions]

1. Initial condition

Actuator does not have to be operated before inserting FPC, as the connector is delivered with the actuator opened.

[Caution]

- Do not close the actuator before inserting FPC. Closing the actuator without FPC could make the contact gap smaller, which could increase the FPC insertion force.
- Do not insert FPC or operate actuator before mounting.

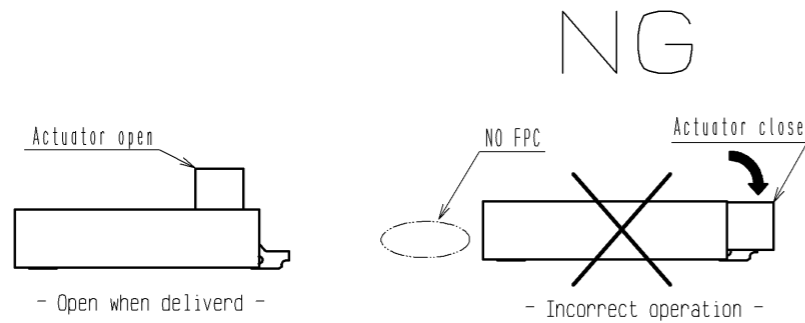

2. How to insert FPC

This connector has contacts on the top. Insert the FPC with the exposed conductors face up.

[Caution]

- Insert the FPC with the actuator opened.
- Do not insert the FPC with the conductor surface face down.
- Insert the FPC into the connector opening horizontally to the PCB plane. Insert it properly to the very end.
- Do not twist the FPC to up and down, right and left or an angle.

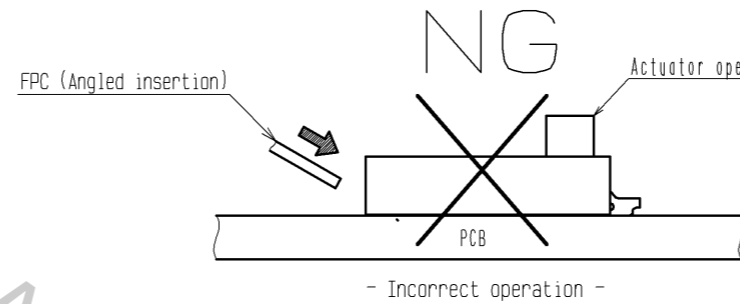
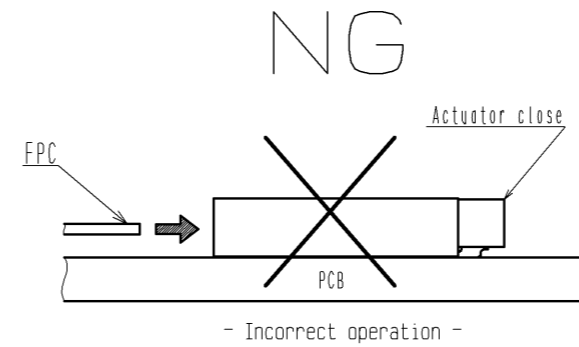
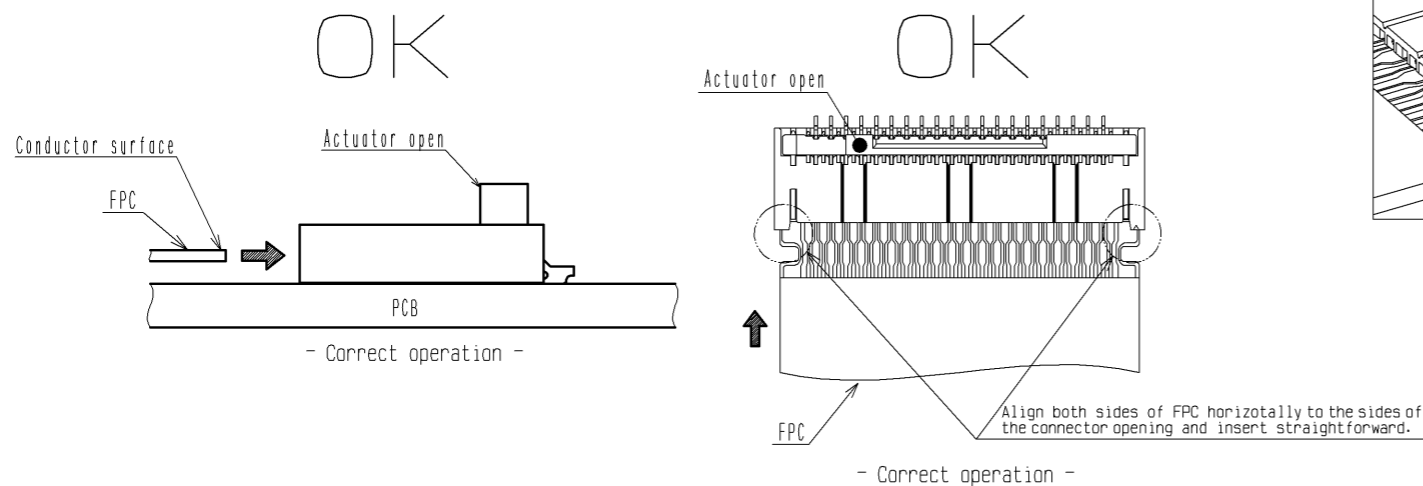

3. FPC insertion check

Chucking metals guide the FPC tabs to the correct position. Make sure that the FPC tabs are located in proper position as shown in the figure below after FPC insertion.

[Caution]

- Do not insert the FPC at an angle and/or stop it before insertion is completed.

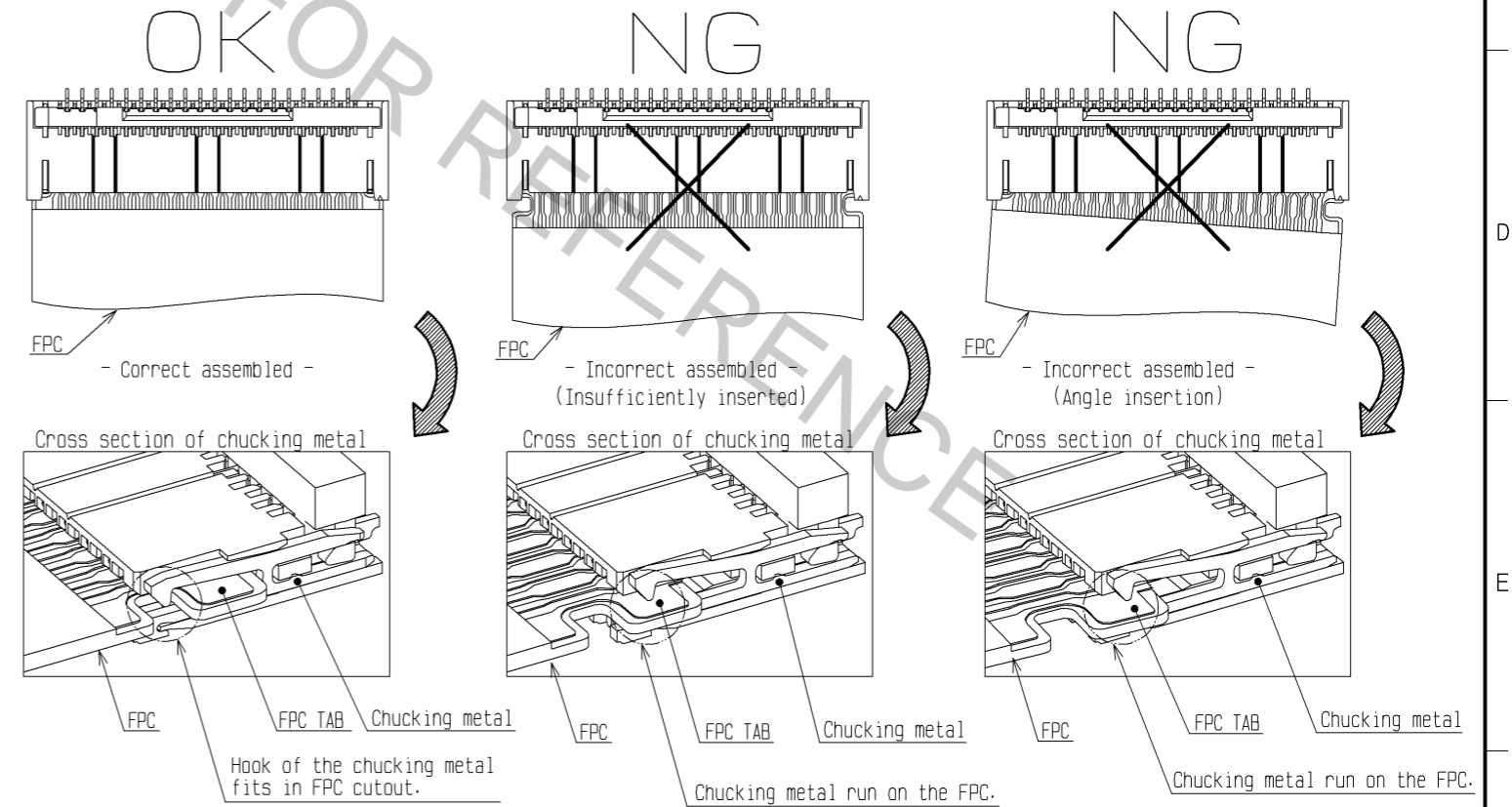

<INSTRUCTION MANUAL (1)>

HRS	DRAWING NO.	EDC3-336359-00
	PART NO.	FH53-41S-0.2SHW
	CODE NO.	CL580-3401-7-00
		△ 4/7

4. How to lock

Apply load to rotate the actuator by 90 degree after inserting the FPC.

[Caution]

- The actuator rotates around the rotational axis as shown below.
- Do not rotate the actuator to the counter direction.
- Do not pinch or pick the actuator to lift.
- Operate the actuator by hand without using sharp tool such as Tweezers.
- To close the actuator, operate at the center of the actuator.
- To close the actuator, do not operate the actuator at one end only.
- Do not apply excess force to the housing during the operation.

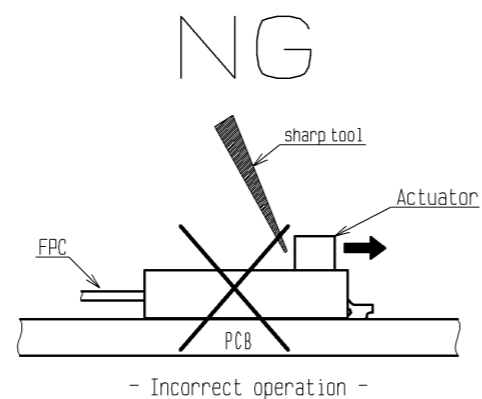
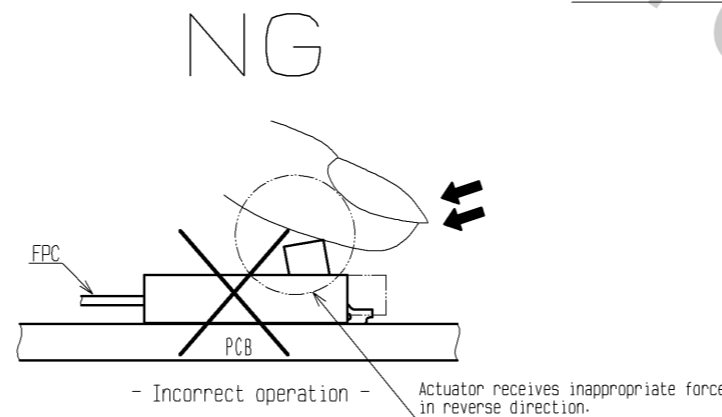
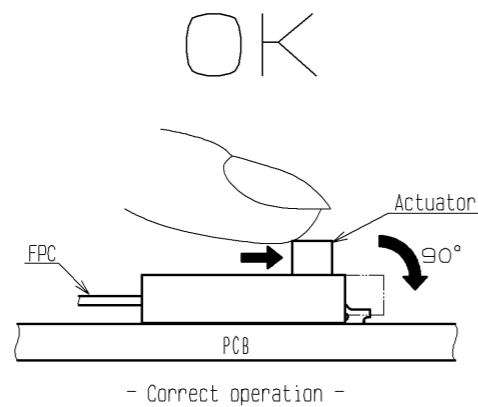
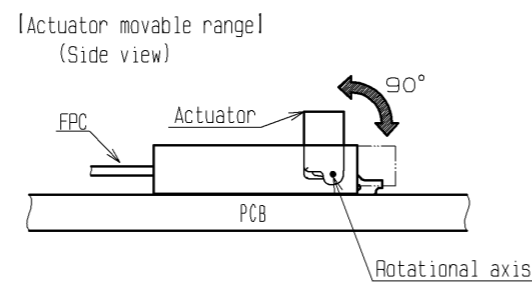

OK

Close the actuator at the center

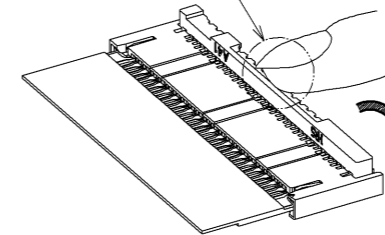

- Correct operation -

NG

Do not operate the actuator at one end only

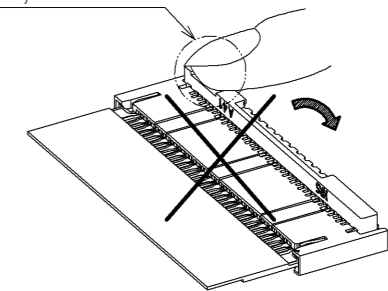

- Incorrect operation -

NG

Do not apply excess force to the housing during the operation.

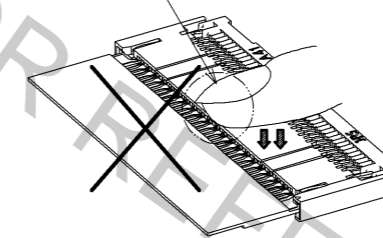

- Incorrect operation -

<INSTRUCTION MANUAL (2)>

HRS

DRAWING NO.	EDC3-336359-00
PART NO.	FH53-41S-0.2SHW
CODE NO.	CL580-3401-7-00

△ 5/7

5. How to unlock

Slowly flip up the actuator to release the lock.

[Caution]

- The actuator is opened up to the movable limit, 90 degree. Do not open the actuator beyond the specified degree or apply excess force to the actuator.
- Open the actuator right above. Do not attempt to open further or to open it by applying horizontal force as this may cause its damage.
- Please note that the connector is back flip style connector, and the opening for FPC insertion and the actuator face the opposite direction. Do not try to lift the actuator at the FPC insertion opening side.
- Operate the actuator by hand without using sharp tool such as Tweezers.
- To open the actuator, operate at the center of the actuator.
- To open the actuator, do not operate the actuator at one end only.

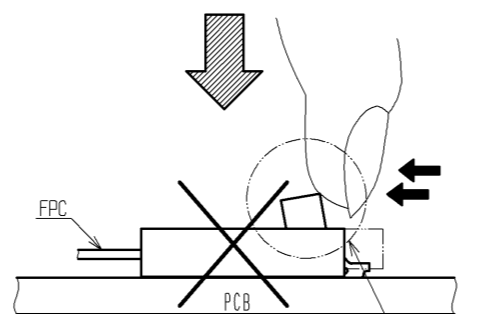
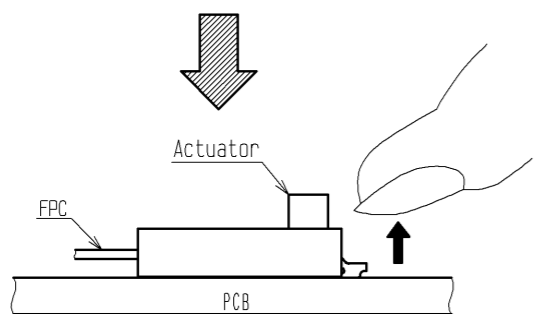
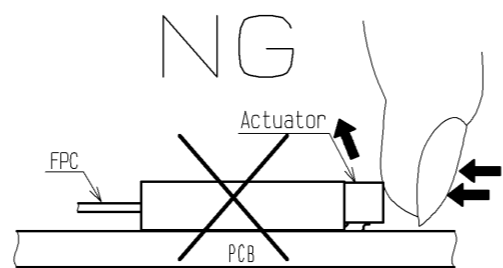
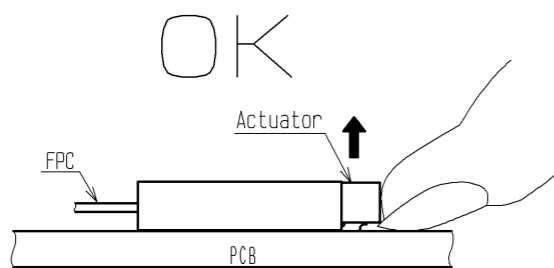

- Correct operation -

- Incorrect operation -

Actuator receives inappropriate force in reverse direction.

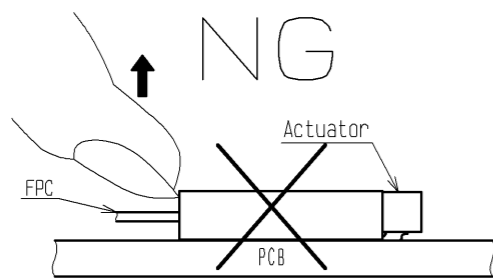

- Incorrect operation -

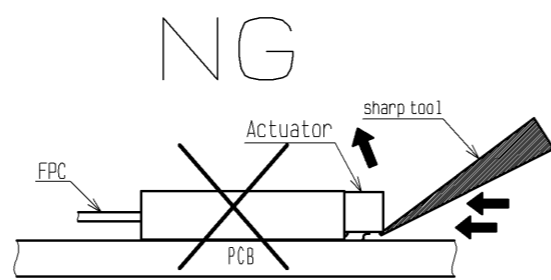

- Incorrect operation -

OK

Open the actuator at the center

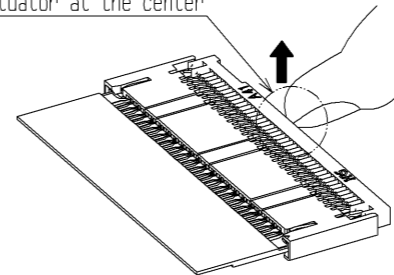

- Correct operation -

NG

Do not operate the actuator at one end only

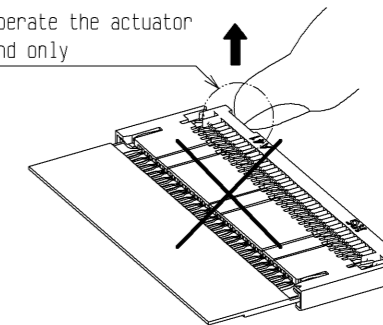

- Incorrect operation -

6. How to remove FPC

After rotating the actuator to the fully opened position carefully withdraw the FPC pulling out at 30 degree angle to the PCB mounting surface.

[Caution]

- This connector has a temporary FPC holding structure with chucking metals. For FPC removal, do not pull out the FPC horizontally.
- Do not attempt to pull the FPC without unlocking the actuator.

OK

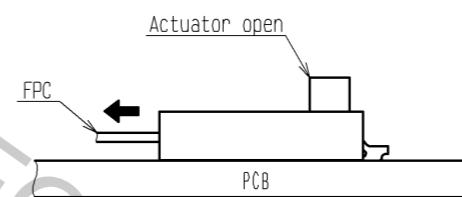

- Correct operation -

NG

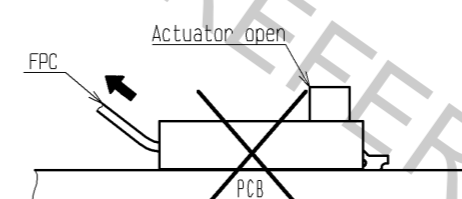

- Incorrect operation -

NG

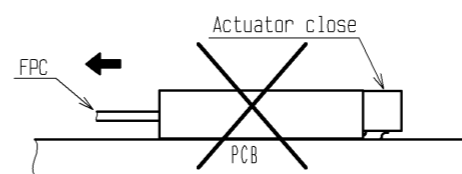

- Incorrect operation -

OK

Actuator open

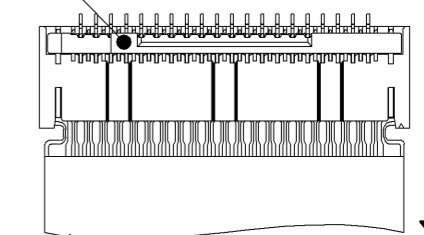

- Correct operation -

NG

Actuator open

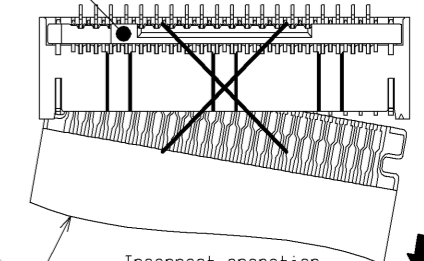

- Incorrect operation -

FPC (Angled withdrawal)

NG

Actuator close

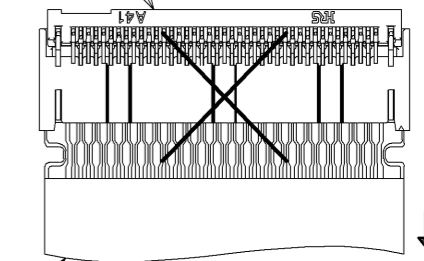

- Incorrect operation -

<INSTRUCTION MANUAL (3)>

HRS

DRAWING NO.	EDC3-336359-00
PART NO.	FH53-41S-0.2SHW
CODE NO.	CL580-3401-7-00

6/7

[Precautions for design]

1. During FPC wiring, ensure that stress is not applied directly to the connector. Do not bend the FPC excessively near the connector during use, or it may cause contact failure or FPC breakage. Stabilizing the FPC is recommended.
2. Keep a sufficient FPC insertion space in the stage of the layout in order to avoid incorrect FPC insertion. Appropriate FPC length and component layout are recommended for assembly ease. Too short FPC length makes assembly difficult.
3. Follow the recommended PCB mounting pattern, stencil opening design and the FPC design.
4. Make adjustments with the FPC manufacturer for FPC bending performance and wire breakage.
5. Keep spaces for the actuator movement and its operation for PCB design and component layout.

[FPC routing after connection]

Depending on a FPC rounding, a load is applied to the connector, and a contact failure may occur. To prevent a failure, take the following notes into a consideration during mechanism design.

[Caution]

- Avoid applying forces to FPC in vertical or horizontal directions. In addition, avoid pulling up and down on the FPC.
- When fixing FPC after FPC cabling, avoid pulling FPC, and route the wire FPC with slack. In this regard, the stiffener is parallel to the PCB.
- Do not mount other components touching to the FPC underneath the FPC stiffener.

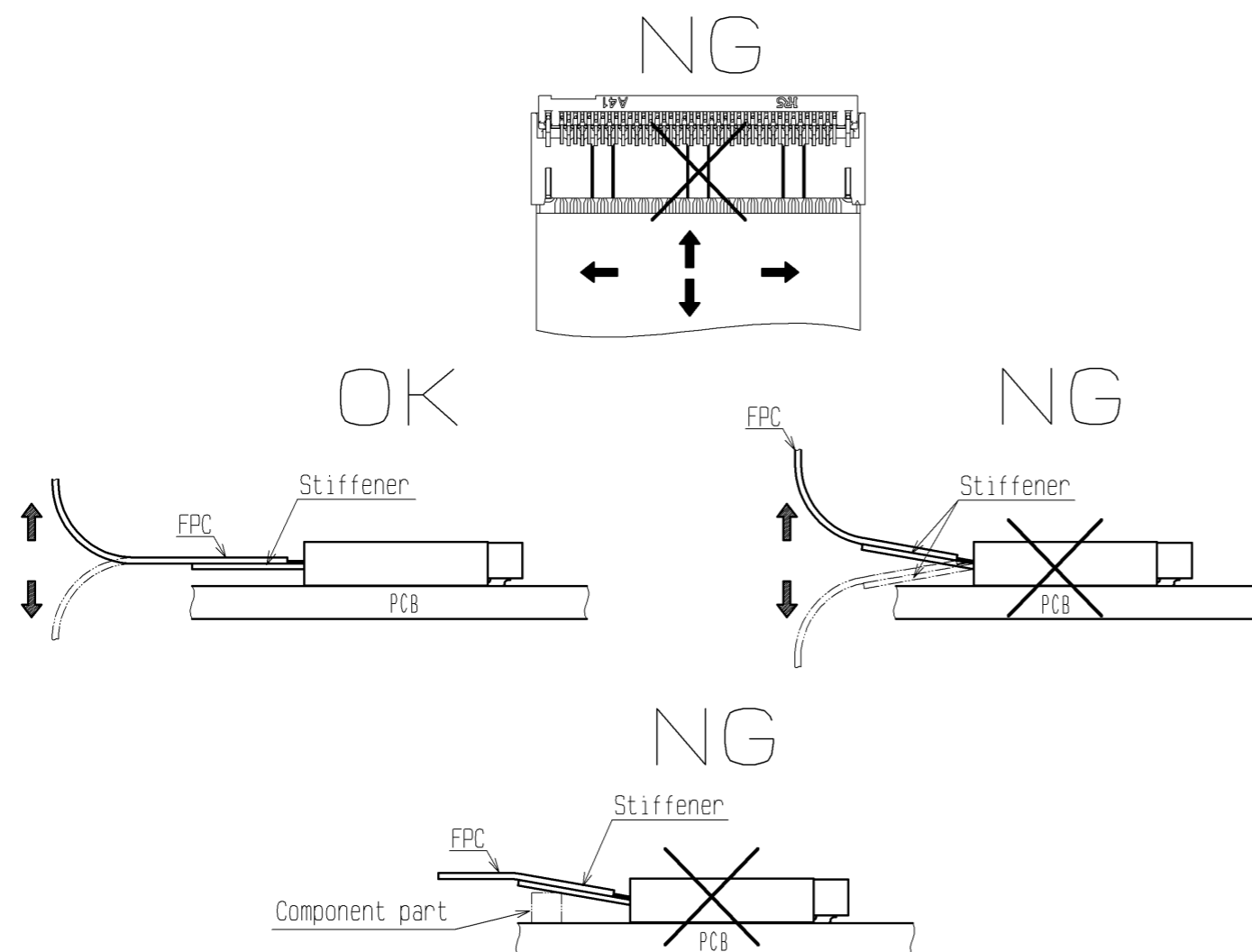

[Instructions for mounting on the PCB]

- ◆ **Warp of PCB**
Minimize warp of the PCB as much as possible. Lead co-planarity including reinforced chucking metals is 0.1 mm or less. Too much warp of the PCB may result in a soldering failure.
- ◆ **Flexible board design**
Please make sure to put a stiffener on the backside of the flexible board. We recommend a glass epoxy material with the thickness of 0.3mm MIN.
- ◆ **Load to Connector**
Do not add 0.5N or greater external force when unreel or pick and place the connector etc. or it may get broken. In addition, do not insert the FPC or operate the connector before mounting.
- ◆ **Reflow temperature profile**
Apply reflow temperature profile within the specified conditions. In individual applications, the actual temperature may vary, depending on solder paste type, volume/thickness and PCB size/thickness. Consult your solder paste and equipment manufacturer for specific recommendations.

[INSTRUCTIONS FOR PCB HANDLING AFTER MOUNTING THE CONNECTOR]

- ◆ **Load to PCB**
Splitting a large PCB into several pieces
Screwing the PCB
Avoid the handling described above so that no force is exerted on the PCB during the assembly process. Otherwise, the connector may become defective.
- ◆ **Amount of Warp**
The warp of a 100mm wide PCB should be 0.5 mm or less. The warp of PCB suffers stress on connector and the connector may become defective.

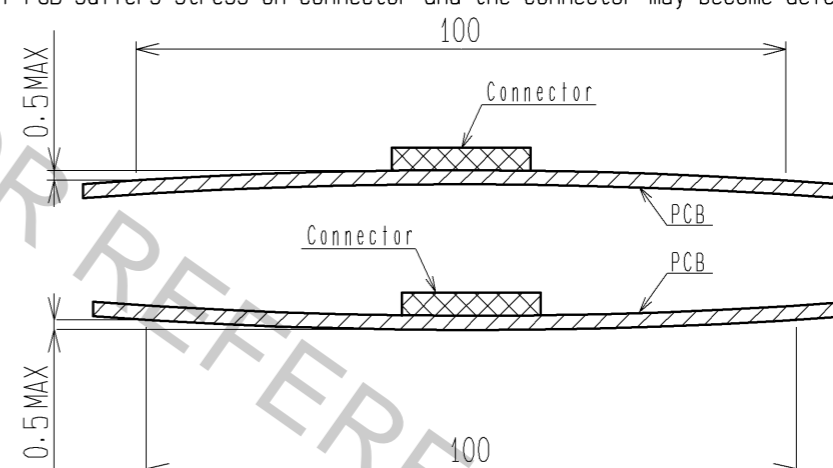

[Other instructions]

- ◆ **Instructions on manual soldering**
Follow the instructions shown below when soldering the connector manually during repair work, etc.
 1. Do not perform manual soldering with the FPC inserted into the connector.
 2. Do not heat the connector excessively. Be very careful not to let the soldering iron contact any parts other than connector leads. Otherwise, the connector may be deformed or melt.
 3. Do not supply excessive solder (or flux).
If excessive solder (or flux) is supplied on the terminals, solder or flux may adhere to the contacts or rotating parts of the actuator, resulting in poor contact or a rotation failure of the actuator. Supplying excessive solder to the chucking metals may hinder actuator rotation, resulting in breakage of the connector.

<INSTRUCTION MANUAL (4)>

HRS	DRAWING NO.	EDC3-336359-00
	PART NO.	FH53-41S-0.2SHW
	CODE NO.	CL580-3401-7-00
		△ 7/7