

CODE No.	CONTACT	A	B	C	D	E	F
CL537-0303-0-86	20	7.1	4.5	5.2	5.6	5.3	8.1
CL537-0305-5-86	30	9.6	7.0	7.7	8.1	7.8	10.6
CL537-0312-0-86	32	10.1	7.5	8.2	8.6	8.3	11.1
CL537-0306-8-86	36	11.1	8.5	9.2	9.6	9.3	12.1
CL537-0307-0-86	40	12.1	9.5	10.2	10.6	10.3	13.1
CL537-0309-6-86	50	14.6	12.0	12.7	13.1	12.8	15.6
CL537-0311-8-86	60	17.1	14.5	15.2	15.6	15.3	18.1

RECOMMEND METAL MASK PATTERN (10:1)

RECOMMENDED LAND PATTERN (10:1)

RECOMMENDED THICKNESS OF SOLDER PASTE : 120 μm

- NOTES 1 LEAD CO-PLANARITY SHALL BE 0.08 mm MAX.
 2 IF THERE IS PATTERN ON PART, THERE IS A POSSIBILITY THAT IT WILL MAKE CONTACT WITH THE LEADS.
 3 REINFORCED METAL FITTINGS AS FOLLOWS.

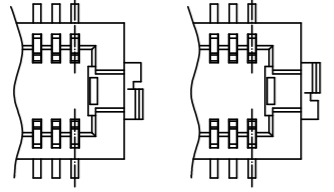

NO.	MATERIAL	FINISH	REMARKS	NO.	MATERIAL	FINISH	REMARKS
2	PHOSPHOR BRONZE		CONTACT AREA:GOLD PLATED 0.2μm min LEAD AREA:GOLD PLATED 0.015μm min OTHERS(UNDER PLATING):NICKEL PLATED 2μm min	7	PS		CLEAR (REINFORCEMENT COLLAR)
1	POLYAMIDE		UL94V-0, NATURAL (BEIGE)	6	PS		BLACK (PLASTIC REEL)
				5	POLYESTER		CLEAR (COVER TAPE)
				4	PS		CLEAR (EMBOSSED CARRIER TAPE)
				3	BRASS		TIN PLATED 2μm min (UNDER PLATING):NICKEL 1μm min

UNITS	SCALE	COUNT	DESCRIPTION OF REVISIONS	DESIGNED	CHECKED	DATE
mm	5 : 1	1	DIS-H-00001678	SH. HOSODA	TS. MIYAZAKI	16.05.30

APPROVED	: KH. IKEDA	13.08.06	DRAWING NO.	EDC3-160937-77
CHECKED	: YH. MICHIDA	13.08.06	PART NO.	DF12B-*DS-0.5V(86)
DESIGNED	: YN. SAKAMOTO	13.08.05	CODE NO.	CL537
DRAWN	: KR. AJITO	13.08.05		

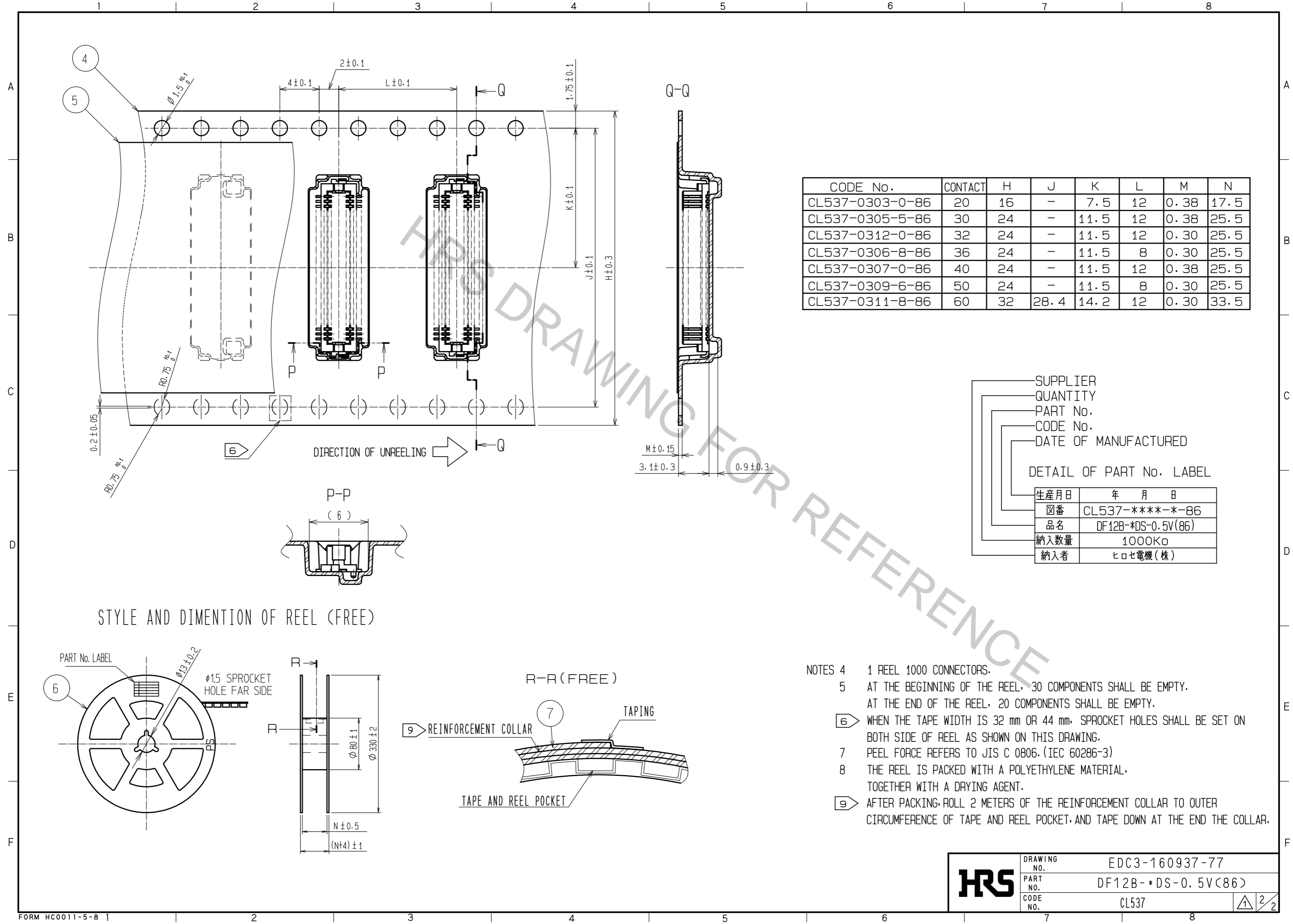

CODE No.	CONTACT	H	J	K	L	M	N
CL537-0303-0-86	20	16	-	7.5	12	0.38	17.5
CL537-0305-5-86	30	24	-	11.5	12	0.38	25.5
CL537-0312-0-86	32	24	-	11.5	12	0.30	25.5
CL537-0306-8-86	36	24	-	11.5	8	0.30	25.5
CL537-0307-0-86	40	24	-	11.5	12	0.38	25.5
CL537-0309-6-86	50	24	-	11.5	8	0.30	25.5
CL537-0311-8-86	60	32	28.4	14.2	12	0.30	33.5

SUPPLIER
 QUANTITY
 PART No.
 CODE No.
 DATE OF MANUFACTURED

DETAIL OF PART No. LABEL

生産月日	年 月 日
図番	CL537-****-*86
品名	DF12B-*DS-0.5V(86)
納入数量	1000K \square
納入者	ヒロセ電機(株)

STYLE AND DIMENTION OF REEL (FREE)

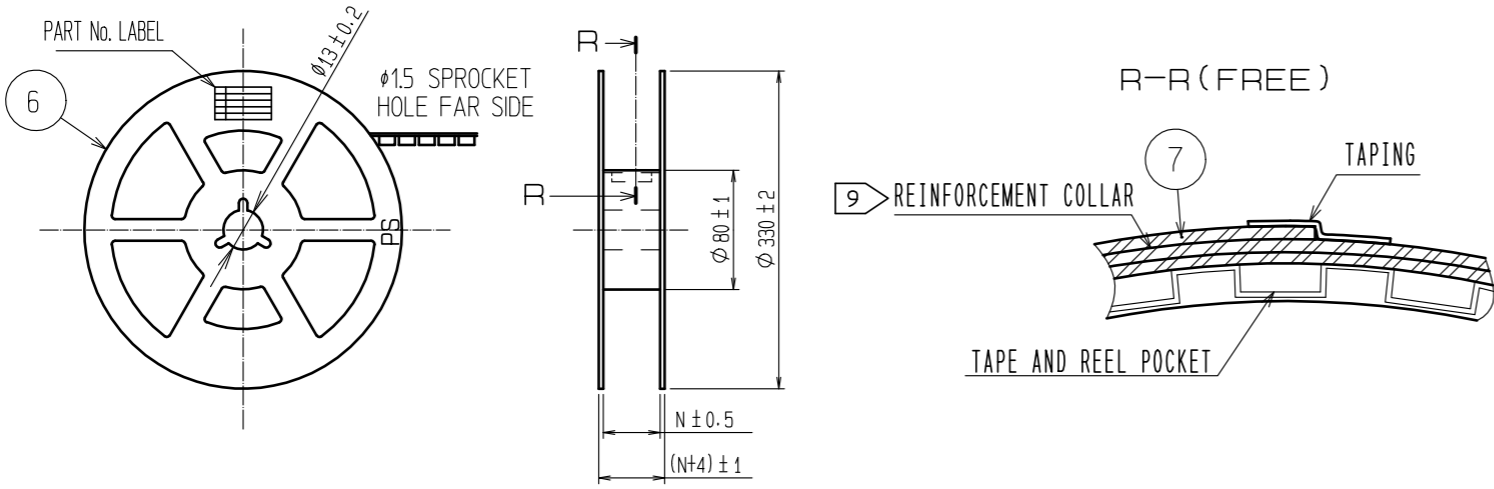

- NOTES
- 1 REEL 1000 CONNECTORS.
 - AT THE BEGINNING OF THE REEL, 30 COMPONENTS SHALL BE EMPTY. AT THE END OF THE REEL, 20 COMPONENTS SHALL BE EMPTY.
 - WHEN THE TAPE WIDTH IS 32 mm OR 44 mm, SPROCKET HOLES SHALL BE SET ON BOTH SIDE OF REEL AS SHOWN ON THIS DRAWING.
 - PEEL FORCE REFERS TO JIS C 0806. (IEC 60286-3)
 - THE REEL IS PACKED WITH A POLYETHYLENE MATERIAL, TOGETHER WITH A DRYING AGENT.
 - AFTER PACKING, ROLL 2 METERS OF THE REINFORCEMENT COLLAR TO OUTER CIRCUMFERENCE OF TAPE AND REEL POCKET, AND TAPE DOWN AT THE END THE COLLAR.

HRS	DRAWING NO.	EDC3-160937-77
	PART NO.	DF12B-*DS-0.5V(86)
	CODE NO.	CL537