

F
E
D
C
B
A

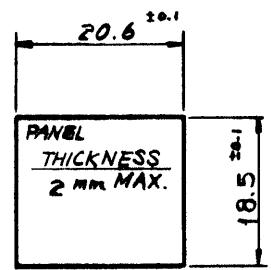

MOUNTING HOLE DETAIL (SCALE 1:1)

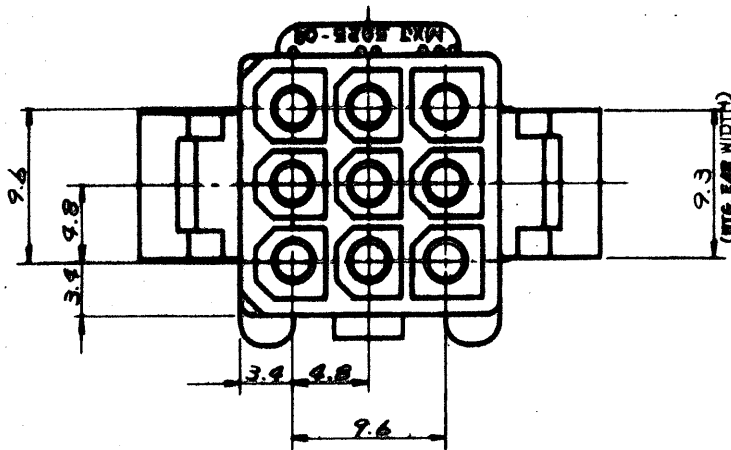
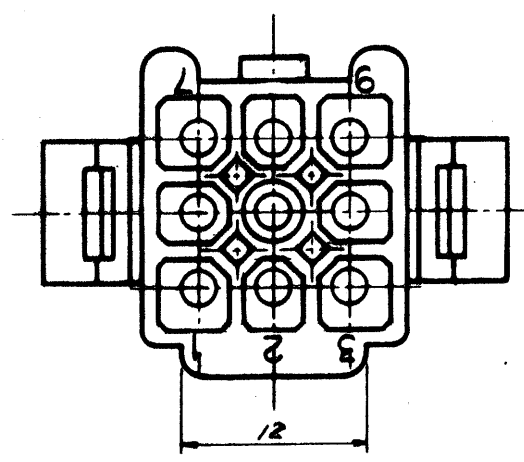
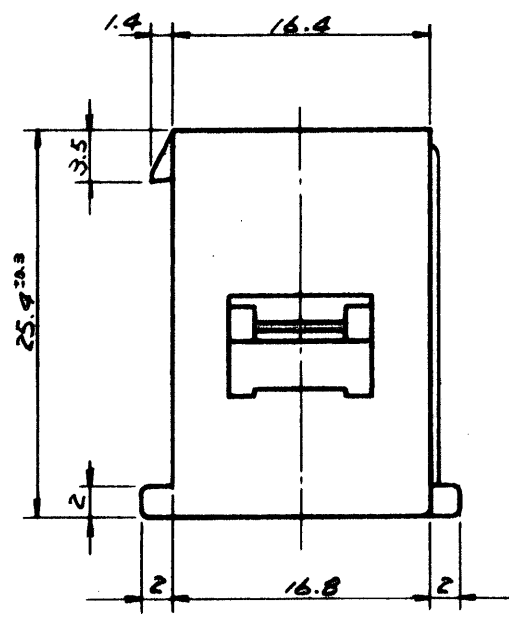
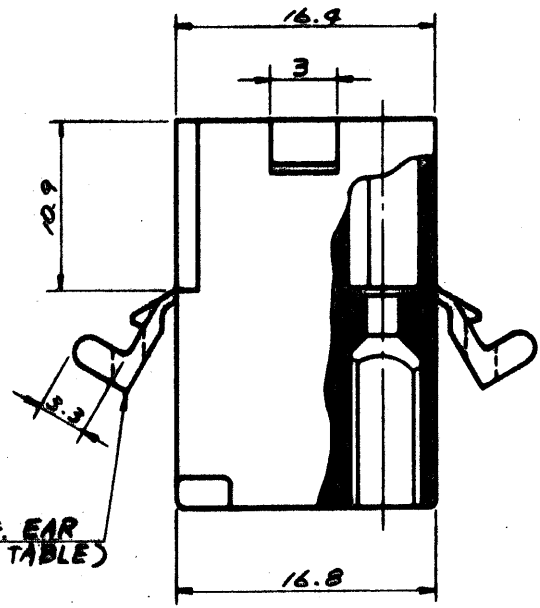

GENERAL TOLERANCES	
10 UNDER	±0.2
10 OVER 30 UNDER	±0.25
30 OVER	±0.3
ANGLE	±3°

	5025-09P1	NO
	5025-09P	YES
EDP NO.	ENG. NO.	MTG. EAR

D	ADDED -09P1 ECN NO. 917	7/17/77	GA	
C	REMOVED "X" ECN NO. 740	7/10/77	GA	
B	リットル加工の穴のサキのNO.	10/17/77	GA	
A	REVISED	10/28/77	GA	
O	PROPOSED	7/77	GA	
記号	変更内容 (Rev.)	Date	Name	

公差 (Tolerances)	.000 → ±0.005 .00 → ±0.05 .0 → ±0.1 . → ±0.3
材料 (MAT'L)	NYLON 66, 94V-2
熱処理 (H.T.)	HRc —#—
仕上げ (Finish)	—#—
Scale	2/1
名称 (Name)	MINI. FIT CONN. 9POS. PLUG HSG.

所要数 (Req)	DRWG. Y. Amano 7/77
	DSN'D M. ENDO 7/77
	CHK'D K. Saito
	APP'D
MOLEX-JAPAN CO., LTD. 日本モレックス株式会社	
No.	SD-5025-09P*
REV.	D

5 4 3 2 1

F
E
D
C
B
A

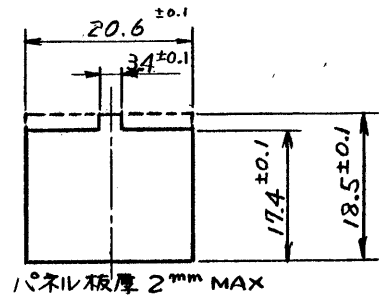
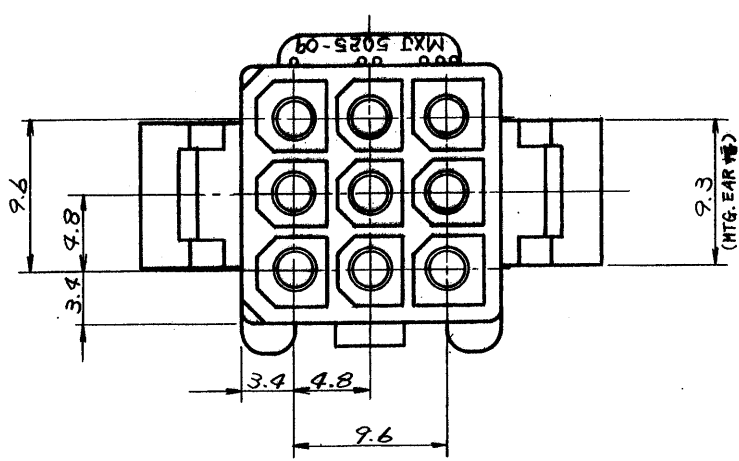

パネルスロット寸法
(SCALE 1:1)

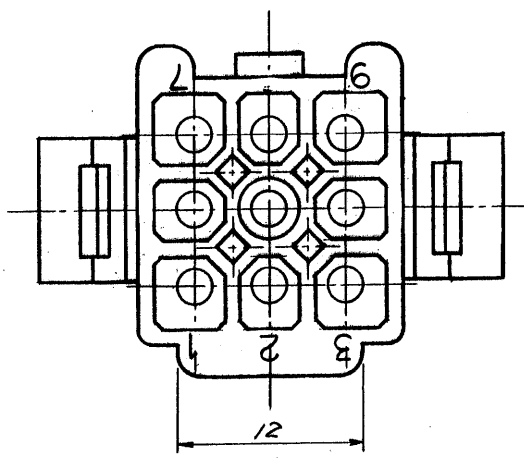
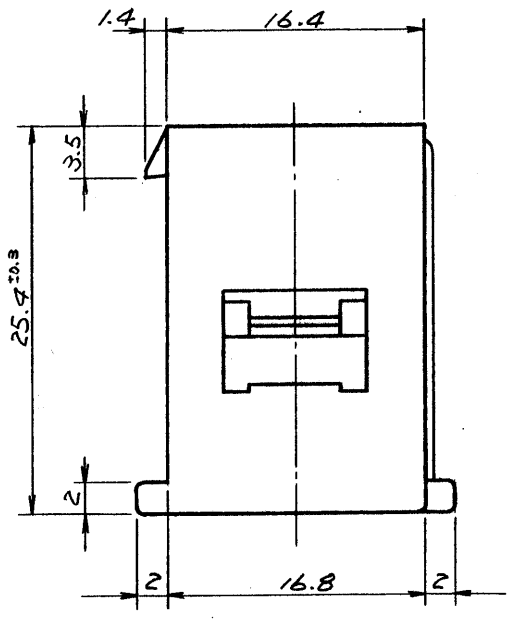
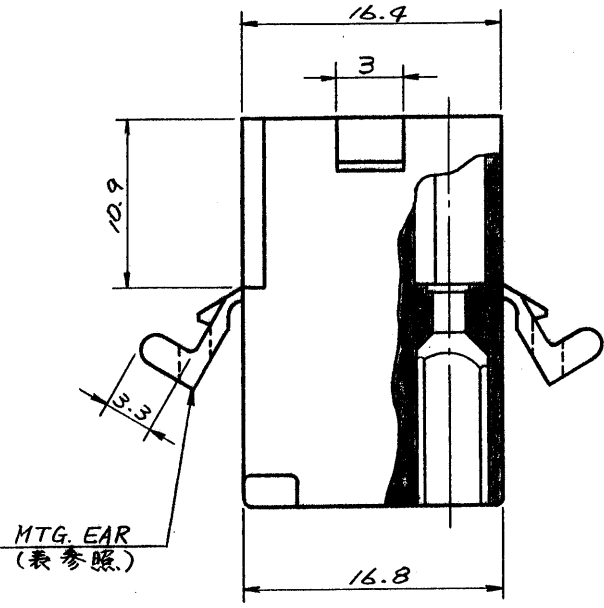

一般公差	
10未満	±0.2
10以上30未満	±0.25
30以上	±0.3
角度	±3°

15-31-1093	5025-09P1	無
15-31-1091	5025-09P	有
EDP NO.	ENG. NO.	MTG. EAR

				公差 (Tolerances) .000 → ±0.005 .00 → ±0.05 .0 → ±0.1 . → ±0.3	所要数 (Req)	DRWG. <i>Y. Awano</i> 9/29 '77	
				材料 (MAT'L) NYLON66, 94V-2		DSN'D <i>M. ENOMOTO</i> 9/26 '77	
				熱処理 (H.T.) HRc — # —	* APP'D <i>W.M.</i>	CHK'D <i>W.M.</i>	
E	REVISED	ECN NO. 1499	11/30/79	K.H.		MOLEX-JAPAN CO., LTD. 日本モレックス株式会社	APP'D
D	ADDED	-09P1 ECN NO. 917	9/5/78	Y	No. SD-5025-09P*		REV. E
C	REMOVED	"X" ECN NO. 748	7/8/78	Y			
B		リットル、パネルスロット、サキット NO.	12/9/77	W.B.			
A	REVISED		10/28/77	W.B.			
O	PROPOSED		9/29/77	W.B.			
記号 (LTR)	変更内容 (Rev.)		Date	Name	Scale 2/1	名称 (Name) MINI. FIT CONN. 9POS. PLUG HSG.	