

DO NOT
SCALE FROM
THIS PRINT

OPA-X-X-X-XX
 PORTS
 SINGLE: -S
 DOUBLE: -D
 KEY
 OPPOSED: -1
 ALIGNED: -2
 FOOTPRINT
 BLANK STANDARD
 FLANGE
 -F: FULL

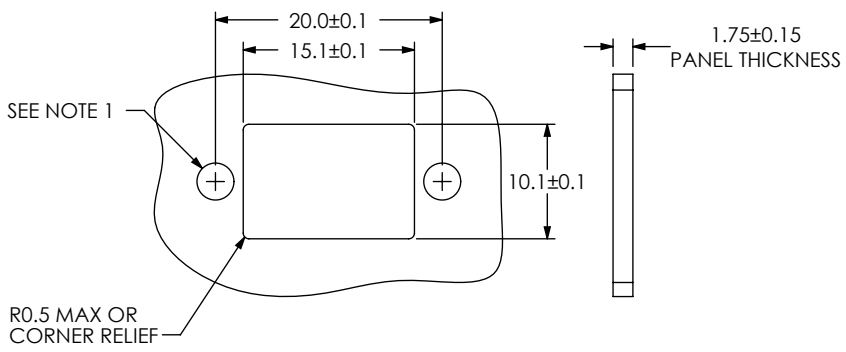

RECOMMENDED MOUNTING CUTOUT
OPA-S-X-F

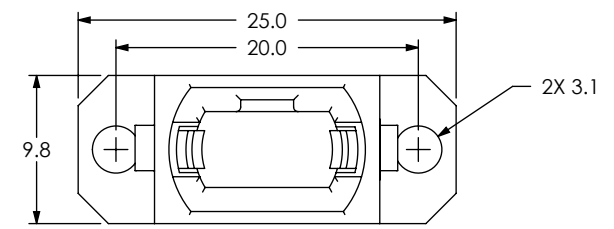
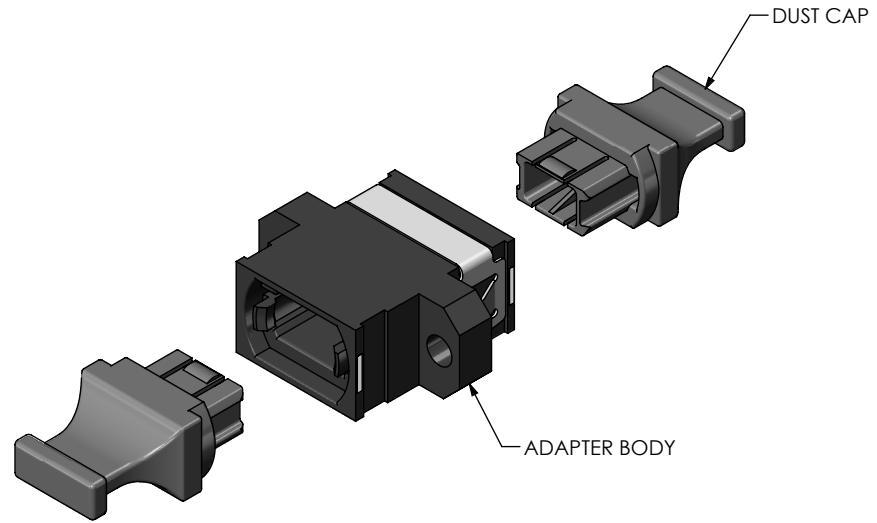
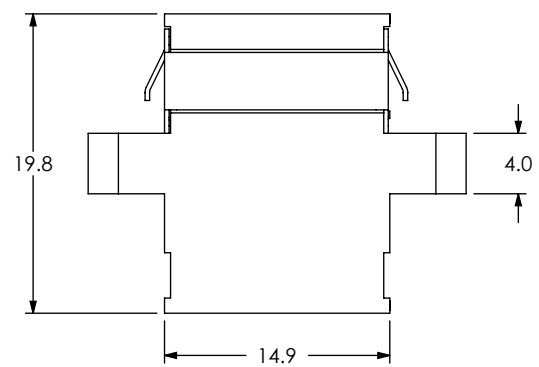

NOTES:
 1. RECOMMEND USE OF M2.5 OR 4-40 SCREW, OR SCREW WITH NUT,
 SCREW HEAD DIAMETER & NUT WIDTH ≤ 5mm
 (SCREW & NUT NOT PROVIDED).
 RECOMMEND 2in-lbf TORQUE FOR SCREW
 MOUNT APPLICATIONS

UNLESS OTHERWISE SPECIFIED, DIMENSIONS ARE IN MILLIMETERS. TOLERANCES ARE: DECIMALS ANGLES X.X: ±0.3 2° X.XX: ±0.05 X.XXX: ±0.025	PROPRIETARY NOTE THIS DOCUMENT CONTAINS INFORMATION CONFIDENTIAL AND PROPRIETARY TO SAMTEC, INC. AND SHALL NOT BE REPRODUCED OR TRANSFERRED TO OTHER DOCUMENTS OR DISCLOSED TO OTHERS OR USED FOR ANY PURPOSE OTHER THAN THAT WHICH IT WAS OBTAINED WITHOUT THE EXPRESSED WRITTEN CONSENT OF SAMTEC, INC.	 520 PARK EAST BLVD., NEW ALBANY, IN 47150 PHONE: 812-944-6733 FAX: 812-948-5047 e-Mail: info@SAMTEC.com code 55322	
		MATERIAL: DO NOT SCALE DRAWING SHEET SCALE: 2:1	
		DESCRIPTION: OPTICAL PANEL ADAPTER DWG. NO. OPA-X-X-X-XX	
BY: JEAN W. 02/05/2015		SHEET 1 OF 3	

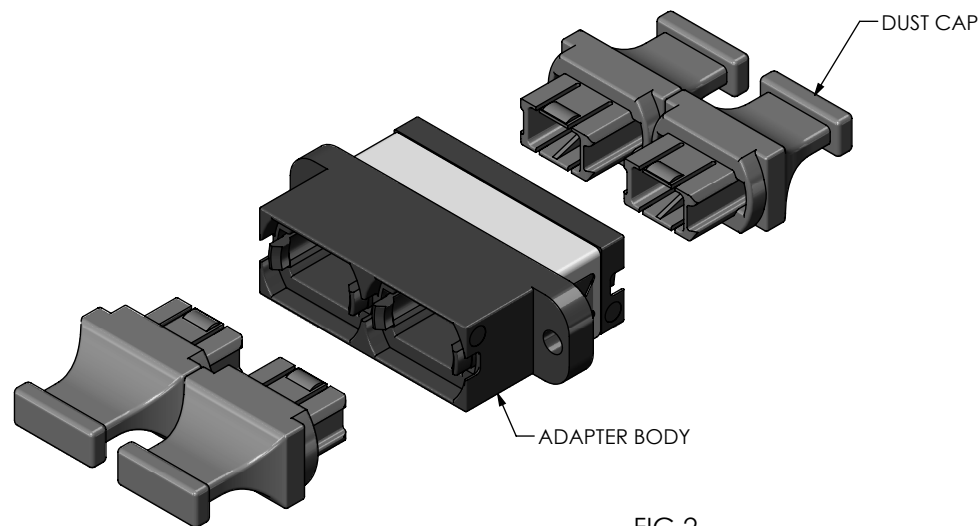
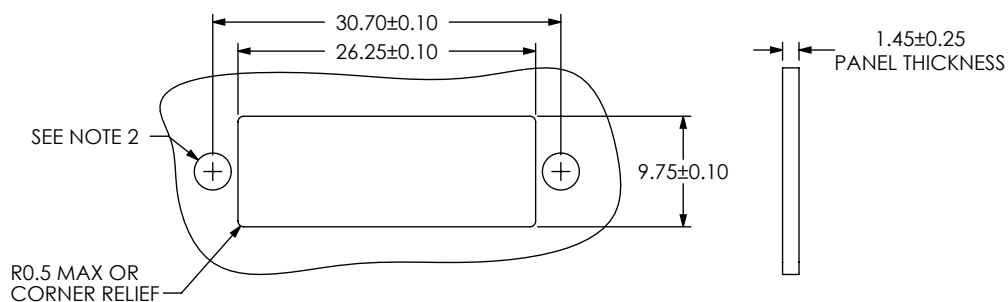
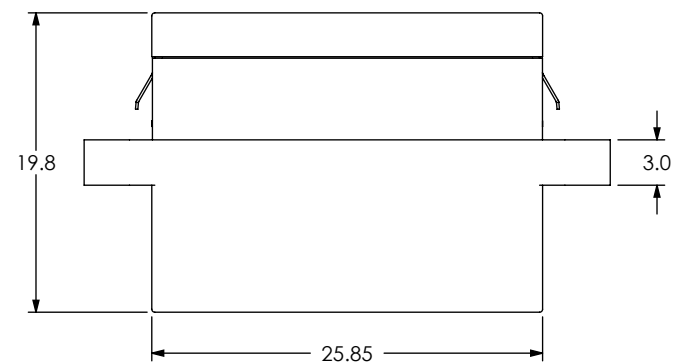
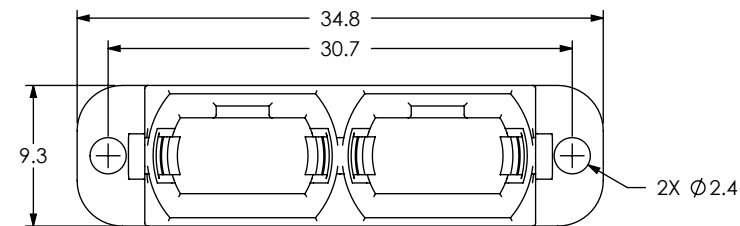

FIG 2
OPA-D-1-F



RECOMMENDED MOUNTING CUTOUT
OPA-D-X-F

- NOTES:
 1. ALSO COMPLIANT WITH FOCIS STANDARD TOLERANCE OF $\pm 0.25\text{mm}$
 2. RECOMMEND USE OF M2 OR 2-56 SCREW, OR SCREW WITH NUT,
 (SCREW & NUT NOT PROVIDED).
 RECOMMEND 2in-lbf TORQUE FOR SCREW MOUNT APPLICATIONS.

PROPRIETARY NOTE

THIS DOCUMENT CONTAINS INFORMATION CONFIDENTIAL AND PROPRIETARY TO SAMTEC, INC. AND SHALL NOT BE REPRODUCED OR TRANSFERRED TO OTHER DOCUMENTS OR DISCLOSED TO OTHERS OR USED FOR ANY PURPOSE OTHER THAN THAT WHICH IT WAS OBTAINED WITHOUT THE EXPRESSED WRITTEN CONSENT OF SAMTEC, INC.



520 PARK EAST BLVD., NEW ALBANY, IN 47150
 PHONE: 812-944-6733 FAX: 812-948-5047
 e-Mail info@SAMTEC.com code 55322

SHEET SCALE: 2:1

DESCRIPTION: OPTICAL PANEL ADAPTER

DWG. NO. OPA-X-X-X-XX

BY: JEAN W. 02/05/2015 SHEET 2 OF 3

MATERIALS TABLE			
PART NUMBER	ADAPTER BODY	SPRING CLIP	DUST CAP
OPA-S-1-F	POLYETHERIMIDE	STAINLESS STEEL	POLYCARBONATE
OPA-S-2-F	POLYETHERIMIDE	STAINLESS STEEL	POLYCARBONATE
OPA-D-1-F	POLYETHERIMIDE	STAINLESS STEEL	POLYCARBONATE
OPA-D-2-F	POLYETHERIMIDE	STAINLESS STEEL	POLYCARBONATE

COLOR TABLE		
PART NUMBER	ADAPTER BODY	DUST CAP
OPA-S-1-F	BLACK	CHARCOAL
OPA-S-2-F	GRAY	CHARCOAL
OPA-D-1-F	BLACK	CHARCOAL
OPA-D-2-F	GRAY	CHARCOAL

BOM TABLE				
PART NUMBER	BOM ITEM	DESCRIPTION	QTY	COST QTY
OPA-S-1-F	CCS-185473-01-CN	BULKHEAD ADAPTER	1	1
	ZBAG-6x8x2-SSB	PACKAGING BAG	0.02	0.02
	LABEL-4X2	LABEL	0	0.00001
OPA-S-2-F	CCS-185473-02-CN	BULKHEAD ADAPTER	1	1
	ZBAG-6x8x2-SSB	PACKAGING BAG	0.02	0.02
	LABEL-4X2	LABEL	0	0.00001
OPA-D-1-F	CCS-185473-03-CN	BULKHEAD ADAPTER	1	1
	ZBAG-6x8x2-SSB	PACKAGING BAG	0.04	0.04
	LABEL-4X2	LABEL	0	0.00002
OPA-D-2-F	CCS-185473-04-CN	BULKHEAD ADAPTER	1	1
	ZBAG-6x8x2-SSB	PACKAGING BAG	0.04	0.04
	LABEL-4X2	LABEL	0	0.00002

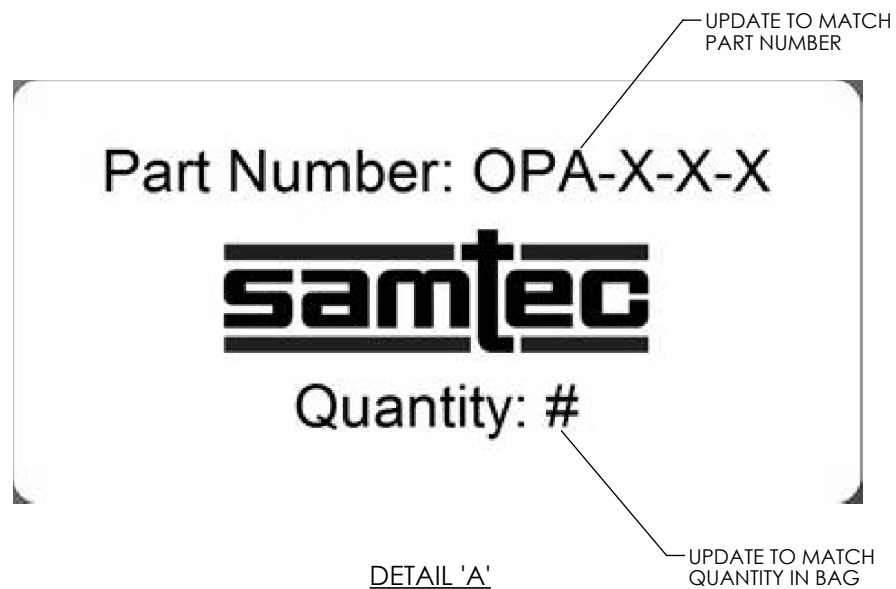
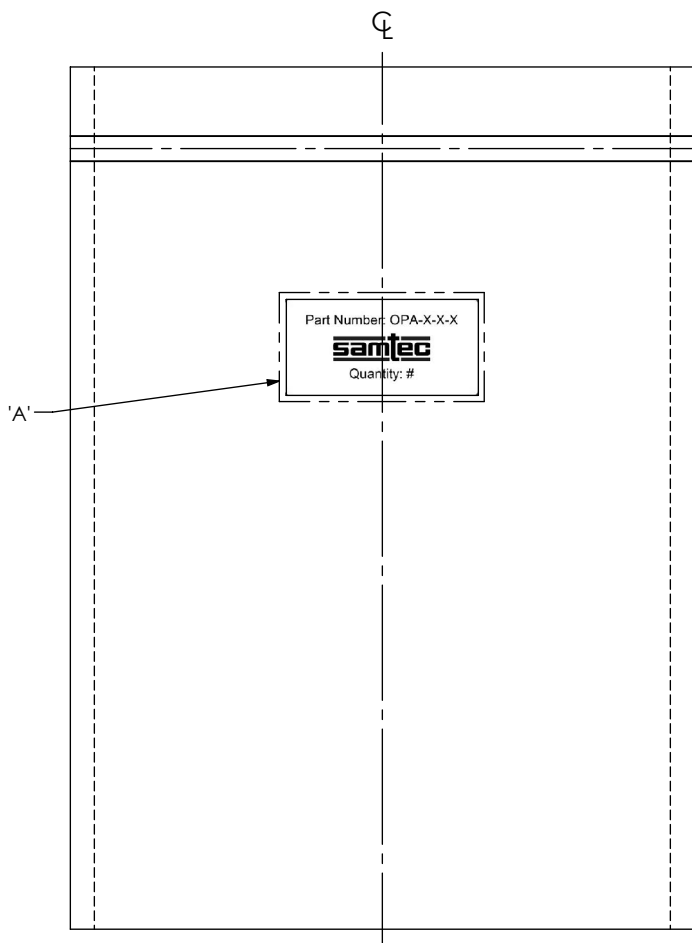

PACKAGING QUANTITY	
PART NUMBER	MAX PER BAG
OPA-S-1-F	50
OPA-S-2-F	50
OPA-D-1-F	25
OPA-D-2-F	25

<p>PROPRIETARY NOTE</p> <p>THIS DOCUMENT CONTAINS INFORMATION CONFIDENTIAL AND PROPRIETARY TO SAMTEC, INC. AND SHALL NOT BE REPRODUCED OR TRANSFERRED TO OTHER DOCUMENTS OR DISCLOSED TO OTHERS OR USED FOR ANY PURPOSE OTHER THAN THAT WHICH IT WAS OBTAINED WITHOUT THE EXPRESSED WRITTEN CONSENT OF SAMTEC, INC.</p>	<p>samtec</p> <p>520 PARK EAST BLVD, NEW ALBANY, IN 47150 PHONE: 812-944-6733 FAX: 812-948-5047 e-Mail info@SAMTEC.com code 53322</p>
	<p>DESCRIPTION: OPTICAL PANEL ADAPTER</p> <p>DWG. NO. OPA-X-X-X-XX</p> <p>BY: JEAN W. 02/05/2015 SHEET 3 OF 3</p>