

SPECIFICATION FOR APPROVAL

PROD. NAME	Radial Inductor	PART NO.	RLH0912-101KBRL		
		REF. :	REV. A (20121004)	PAGE	1

I . Configuration and dimensions :

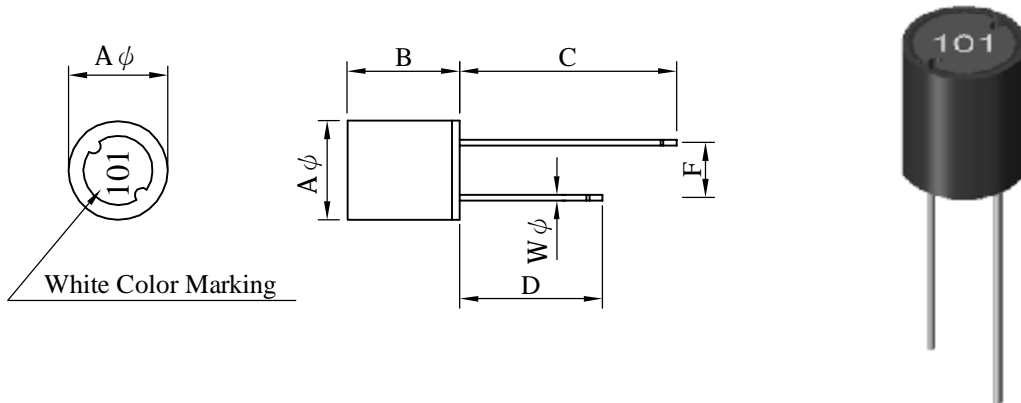

Unit : m/m

Aφ	B	C	D	F	Wφ
9.30 ±0.3	11.80 ±0.3	25.00 ±5.0	18.00 ±5.0	5.00 ±0.3	0.65 ±0.05

II . Description :

- a . Ferrite drum core construction.
- b . Enamelled copper wire : F class
- c . Product weight : 1.87 g (ref.)
- d . Moisture sensitivity Level 1
- e . Products comply with RoHS' requirements
- f . Halogen free available

III . General specification :

- a . Storage temp. : -40°C ~ +125°C
- b . Operating temp. : -40°C ~ +125°C
(Temp. rise included.)

SPECIFICATION FOR APPROVAL

PROD. NAME	Radial Inductor	PART NO.		RLH0912-101KBRL		
		REF. :	REV. A (20121004)	PAGE	2	

IV . Electrical characteristics :

PART NO.	Inductance (μ H)	Q ref.	Test Freq. (Hz)		SRF (MHz) typ.	RDC (Ω) max.	IDC (A) max.
			L	Q			
RLH0912-101KBRL	100.0 \pm 10%	55	1K	0.796M	7.2	0.330	0.66

- 1). Electrical specifications at 25°C
- 2). IDC base on Temp. rise 20°C max.

SPECIFICATION FOR APPROVAL

PROD. NAME	Radial Inductor	PART NO.	RLH0912-101KBRL		
		REF. :	REV. A (20121004)	PAGE	3

V . Packaging information :

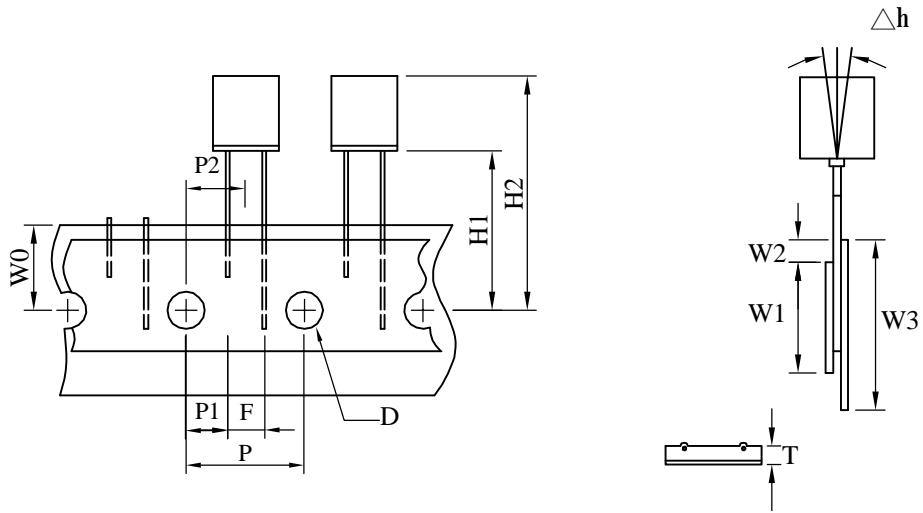

Item	Symbol	Specification			
		Milimeter		Inch	
		Size	Tolerance	Size	Tolerance
Tape feed hole diameter	D	4.00	±0.20	0.157	±0.008
Component lead pitch	F	5.00	±0.50	0.200	±0.020
Front-to-rear delectton	△h	2.00	max.	0.079	max.
Feed hole to bottom of component	H1	18.50	±0.80	0.728	±0.040
Feed hold to overall component height	H2	30.30	±1.00	1.083	±0.040
Feed hole pitch	P	12.70	±0.30	0.500	±0.012
Lead location	P1	3.85	±0.70	0.152	±0.028
Center of component location	P2	6.35	±1.30	0.250	±0.051
Overall taped package thinkness	T	1.42	max.	0.056	max.
Feed hole location	W0	9.00	±0.50	0.354	±0.020
Adhesive tape width	W1	15.00	±0.50	0.598	±0.020
Adhesive tape position	W2	4.00	max.	0.157	max.
Tape wide	W3	18.00	±0.50	0.709	±0.020

BOURNS INDUCTIVE COMPONENTS

SPECIFICATION FOR APPROVAL

PROD. NAME	Radial Inductor	PART NO.	RLH0912-101KBRL		
		REF. :	REV. A (20121004)	PAGE	4

Packaging information :

1 、 Internal packaging : 500 Pcs / Reel

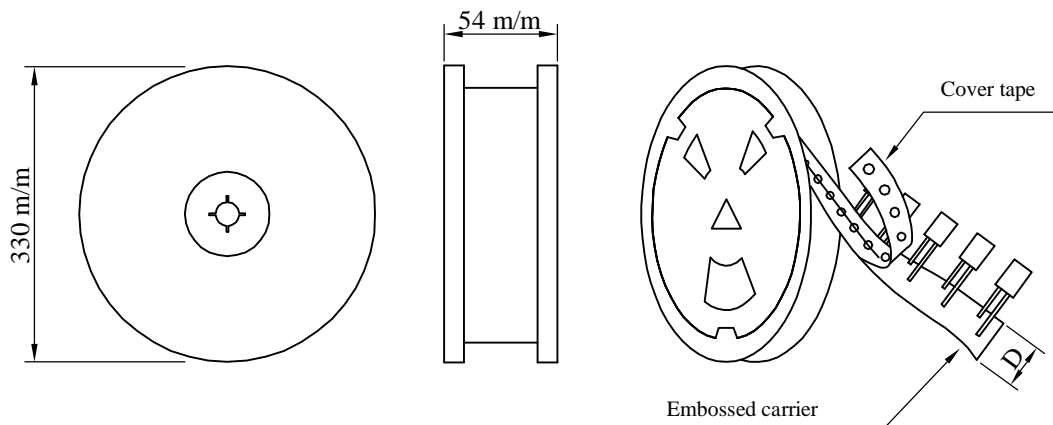

※Carrier tape width : D

2 、 Middle packaging : 1 R / Box

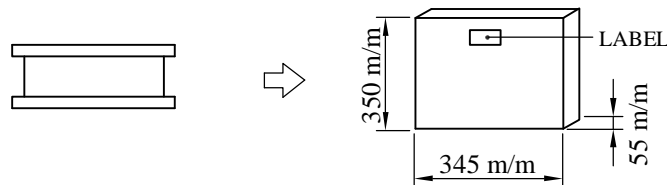

3 、 External packaging : 6 Box / Carton

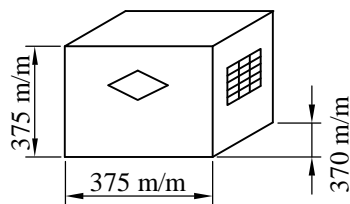

Q'TY & G.W.Per Packaging

PART NO.	Inner : Reel			Outer : Carton		
	Q'TY(pcs)	G.W.(gw)	Style (m/m)	Q'TY(pcs)	G.W.(Kg)	Size (cm)
RLH0912	500	1100	13-54	3,000	7.20	37.5x37.0x37.5

BOURNS INDUCTIVE COMPONENTS

SPECIFICATION FOR APPROVAL

PROD. NAME	Radial Inductor	PART NO.	RLH0912-101KBRL		
		REF. :	REV. A (20121004)	PAGE	5

VI . Reliability test :

Item	Reference documents	Test Condition	Test Specification
1.High Temperature Exposure	MIL-STD-202 Method 108	1.Temperature: 125°C 2.Time:96 hours.	1.No mechanical and electrical damage. 2.Inductance shall not change more than ±10%.
2.Temperature Cycling	JESD22 Method JA-104	1.Temperature: -40°C ~ 125°C 2.Number of cycle:96 cycle 3.Dwell time:30 minutes	1.No mechanical and electrical damage. 2.Inductance shall not change more than ±10%.
3.Biased Humidity Test	MIL-STD-202 Method 103	1.Temperature: 85±5 °C 2.Time:96 hours 3.Humidity: 85±5% RH.	1.No mechanical and electrical damage. 2.Inductance shall not change more than ±10%.
4.Operational Life	MIL-PRF-27	1.Temperature: 125°C 2.Time:96 hours. 3.Apply rated current.	1.No mechanical and electrical damage. 2.Inductance shall not change more than ±10%.
5.Exeternal Visual	MIL-STD-883 Method 2009	Inspect product constructions, marking and workmanship.	1.No pollution on the surface of products. 2.Clear marking. 3.No crack.
6.Physical Dimensions	JESD22 Method JB-100	Verify physical dimensions to the applicable product detail specification.	Per product specification standard
7.Resistance to solvents	MIL-STD-202 Method 215	Immerse into solvent for 3±0.5 minutes & brush 10 times for 3 cycles.	1.No body change in apperarence. 2.No marking blurred. 3.Inductance shall not change more than ±10%.
8.Vibration Test	MIL-STD-202 Method 204	1.Frequency and Amplitued : 10-2000-10 Hz, 1.5 mm. 2.Direction:X, Y, Z 3.Test duration:2 hours for each direction, 6 hours in total.	1.No mechanical and electrical damage. 2.Inductance shall not change more than ±10%.
9.Resistance To Soldering Heat Test	MIL-STD-202 Method 210	1.Method : Dip 2.Temperature : 260±5 3.Time (temp. ≥ 260°C) : 10 second. 4.Number of times : 3 times.	1.No mechanical and electrical damage. 2.Inductance shall not change more than ±10%.
10.Rated current	MIL-STD-202 Method 330	Apply rated current for 5 second.	1.No mechanical and electrical damage. 2.Inductance shall not change more than ±10%.
11.Temperature rise	MIL-PRF-27	Apply rated current for 10 minutes.	1.No mechanical and electrical damage. 2.Inductance shall not change more than ±10%.
12.Over load	MIL-PRF-27	Apply double as rated current for 5 minutes. (It's not application to some special design)	1.No mechanical and electrical damage. 2.Inductance shall not change more than ±10%.
13.Solderability Test	J-STD-002	Dip pads in flux then dip in solder pot at 240±5 for 5 senconds.	Teminals area must have 95% min. Solder coverage.
14.Electrical Characteriazation	User Spec.	1.Operating temperature : -40°C ~125°C 2.Room temperature : 25°C.	1.No mechanical and electrical damage. 2.Inductance shall not change more than ±10%.
15.Withstanding Voltage Test	MIL-STD-202 Method 201	1.DC:500V 2.Time:1minutes	1.During the test no breakdown. 2.The characteristic is normal after test.
16.Drop	JESD22-B111	Packaged & Drop down from 1m.In 1 angle lridges & 2 surfaces orientation.	1.No case deformation or change in appearance. 2.Inductance shall not change more than ±10%.
17.Terminal Strength Test	JIS-C-6429	1.Apply push force to samples mounted on PCB. 2.Force of 1.8 kg for 60±1 seconds.	After test, inductors shall be no mechanical damage.

BOURNS INDUCTIVE COMPONENTS