

## DETAILS

<b>Product Number</b>	C13605_HB-2X2-RW
<b>Family</b>	HB
<b>Type</b>	Lens array
<b>Color</b>	clear
<b>Diameter</b>	50x50 mm
<b>Height</b>	8,5 mm
<b>Style</b>	square
<b>Optic Material</b>	PMMA
<b>Holder Material</b>	
<b>Fastening</b>	glue, screw, pin
<b>Status</b>	production ready
<b>ROHS Compliant</b>	Yes
<b>Date Updated</b>	21/04/2016



## OPTICAL PROPERTIES

LED	Viewing Angle	Light Beam	Efficiency	cd/lm	Connector
XT-E	44 deg	Wide	91 %	1.600	-
XP-G2	48 deg	Wide	91 %	1.400	-
XP-G	50 deg	Wide	89 %	1.300	-
XP-E	51 deg	Wide	89 %	1.400	-
XB-D	46 deg	Wide	88 %	1.600	-
XP-G3	48 deg	Wide	86 %	1.200	-
NCSxx19A	49 deg	Wide	90 %	1.500	-
NVSxx19A	52 deg	Wide	88 %	1.300	-
NVSxx19B/NVSxx19C	51 deg	Wide	90 %	1.300	-
NVSxE21A	37 deg	Wide	84 %	1.600	-
Oslon Square PC	50 deg	Wide	90 %	1.400	-
Oslon SSL 80	46 deg	Wide	90 %	1.700	-
Oslon Square Gen3	49 deg	Wide	89 %	1.300	-
LH351Z	48 deg	Wide	90 %	1.400	-
Z5M1/Z5M2	49 deg	Wide	90 %	1.400	-
Z8Y15	46 deg	Wide	88 %	1.400	-
Z8Y19	47 deg	Wide	87 %	1.300	-
TL1L4	47 deg	Wide	83 %	1.300	-
RLE G1 49x223mm 4000lm xxx EXC OT	5 deg	Wide	94 %	1.400	-
RLE G1 49x245mm 4000lm xxx EXC OT	5 deg	Wide	94 %	1.400	-
RLE G1 49x121mm 2000lm xxx EXC OT	5 deg	Wide	94 %	1.400	-
RLE G1 49x133mm 2000lm xxx EXC OT	5 deg	Wide	94 %	1.400	-

D

C

B

A

4

4

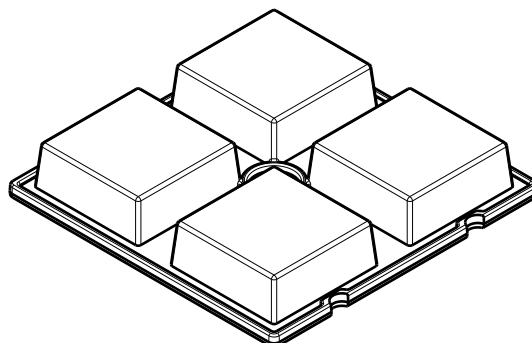
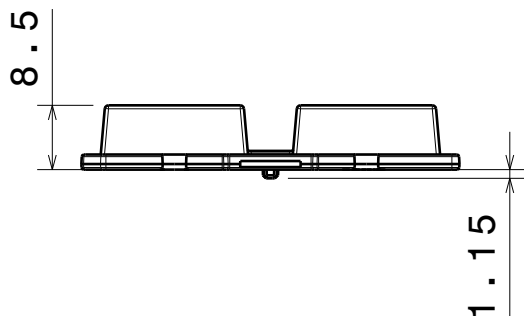

3

3

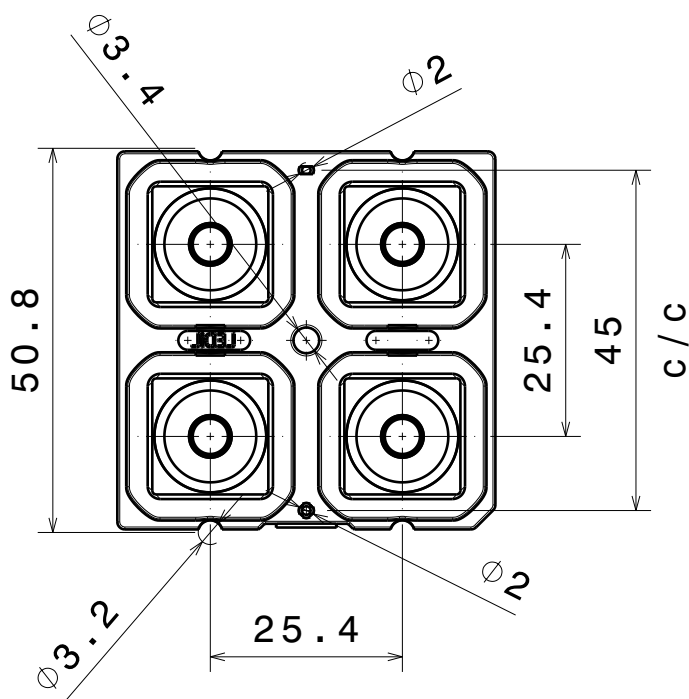
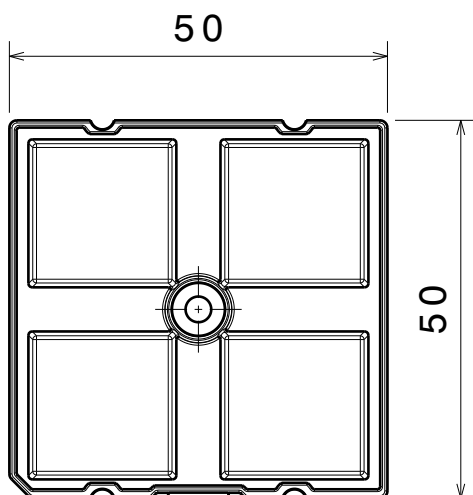

2

2

INDEX	PART NO	DESCRIPTION	MATERIAL	COLOUR
1	C13605	HB-2x2-RW	PMMA	

Tolerances if not otherwise shown  
According to DIN ISO 2768-1  
Linear measures:  
up to 30mm class M, otherwise class C  
According to DIN ISO 2768-2  
Form and position: class L

LEDiL

Ledil Oy  
Salorankatu 10  
FIN 24240 SALO  
Finland

THIRD ANGLE PROJECTION:



DRAWING TITLE

C13605\_HB-2x2-RW

This drawing is the property  
of LEDiL Oy. It may not be  
reproduced, copied or  
communicated without a written  
agreement with LEDiL Oy.

SIZE PART NUMBER

A4

C13605

SCALE	1:1	WEIGHT	10,6 g	SHEET	1/1
-------	-----	--------	--------	-------	-----

1

1

D

A

Luminaire: Ledil Oy C13605\_HB-2X2-RW (Cree XT-E 390lm @ 250mA) Efficiency=89%  
Lamps: 1 x Cree XT-E 390lm @ 250mA CCT=5717K P=3W I=250mA

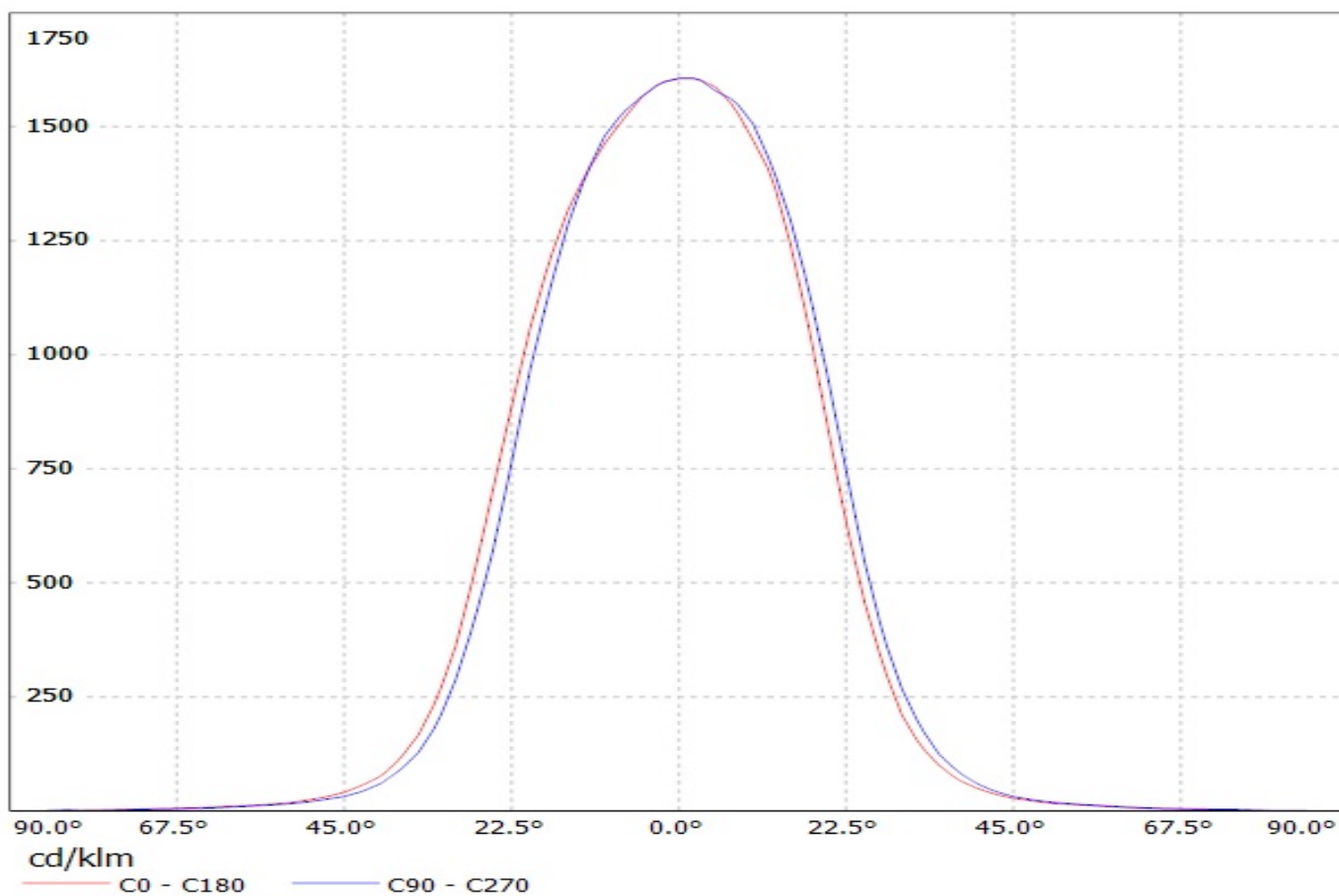

Luminaire: Ledil Oy C13605\_HB-2X2-RW (Cree XP-G2 408lm Im @ 250mA) Efficiency=91%  
Lamps: 1 x Cree XP-G2 408lm Im @ 250mA CCT=7181K P=3W I=250mA

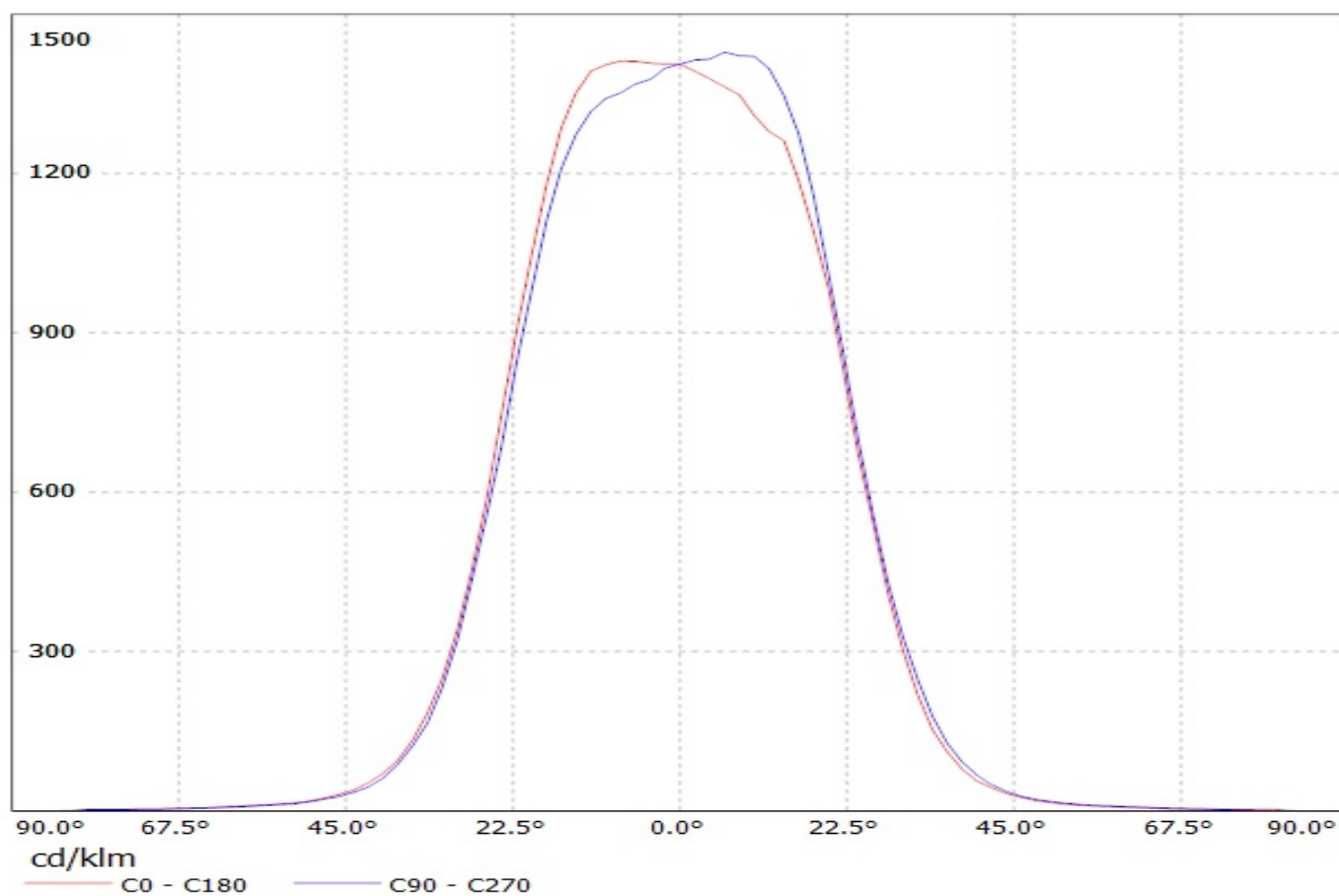

Luminaire: Ledil Oy C13605\_HB-2X2-RW\_(XP-G) Efficiency=89%  
Lamps: 1 x Cree XP-G (254lm @ 250mA) CCT=3300K P=2.9W I=250mA

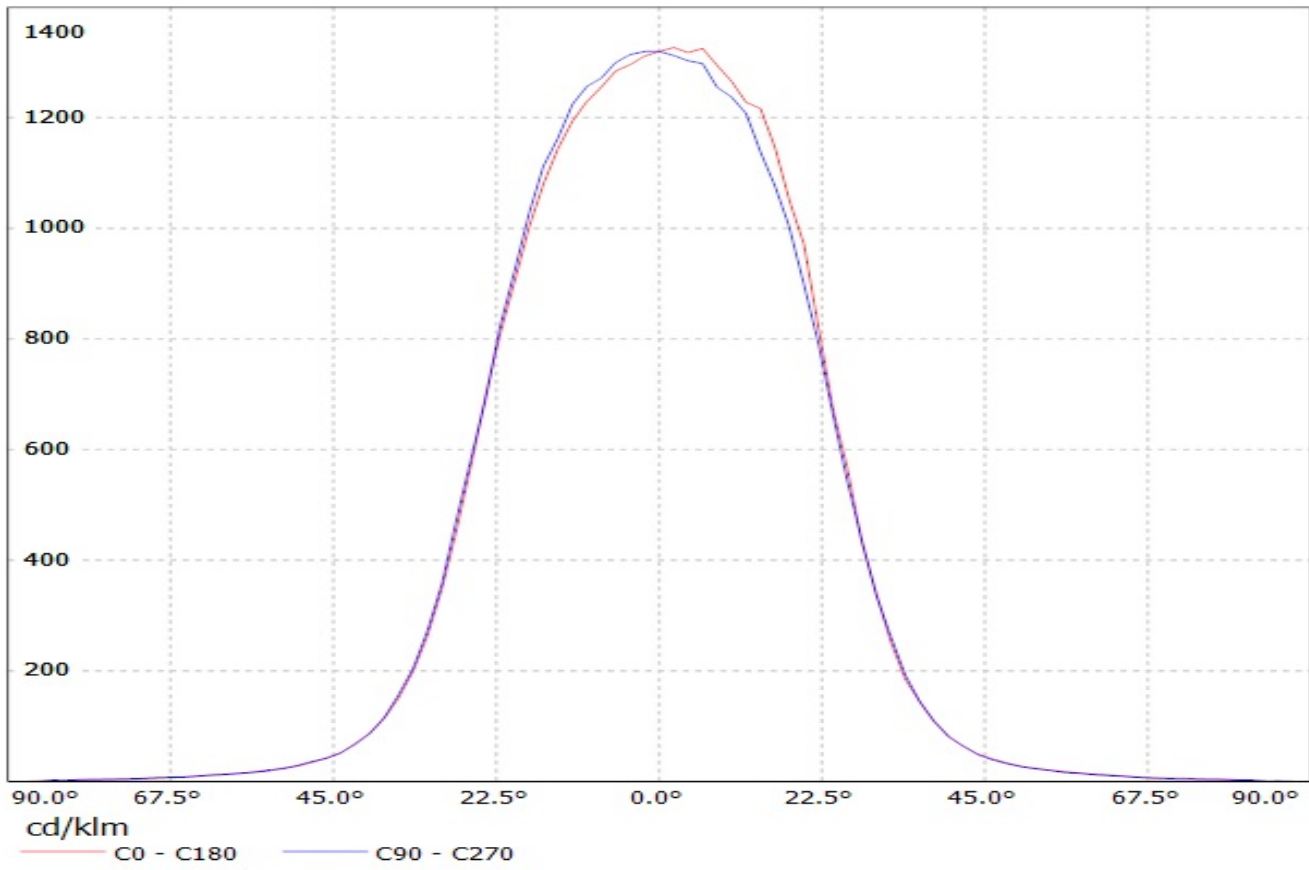

Luminaire: Ledil Oy C13605\_HB-2x2-RW\_(XP-E) Efficiency=89%  
Lamps: 1 x Cree XP-E (XPEWHT-L1-3C0-W5-0-06) 302lm @ 250mA CCT=5400K P=3.1W I=250mA

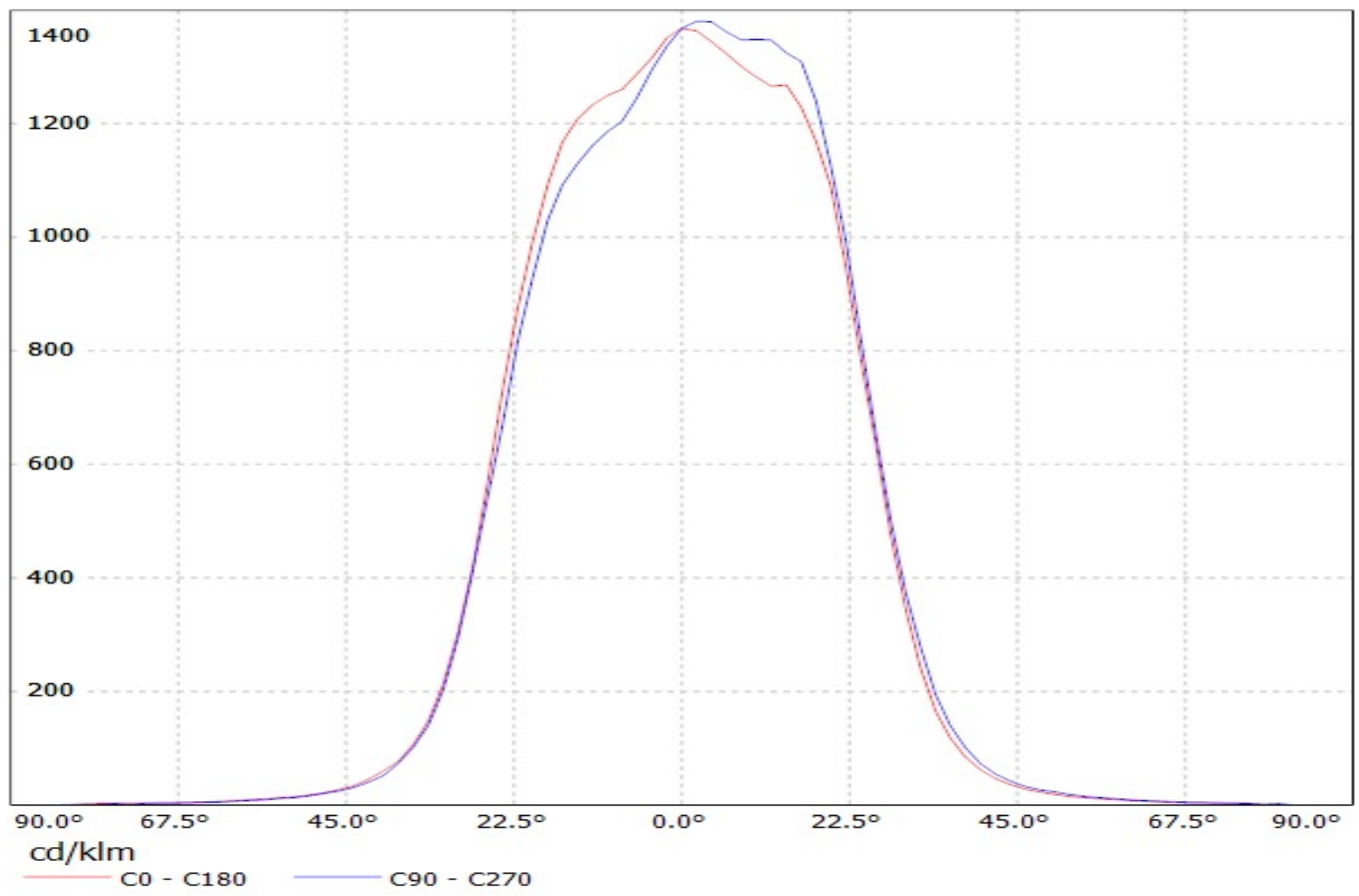

Luminaire: Ledil Oy C13605\_HB-2X2-RW\_(XB-D) Efficiency=88%  
Lamps: 1 x Cree XB-D (365lm @ 250mA) CCT=6800K P=3.1W I=250mA

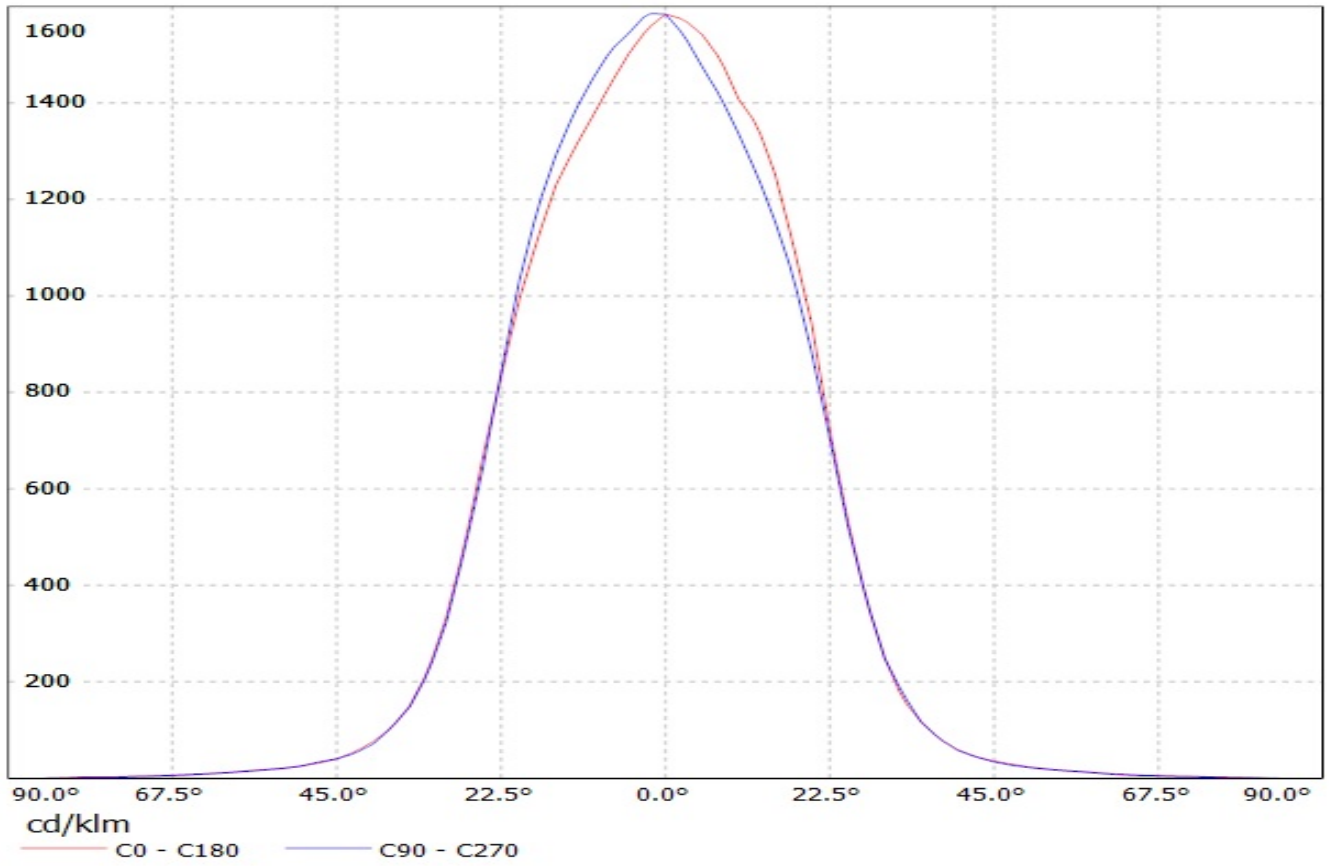

Luminaire: Ledil C13605\_HB-2x2-RW\_(XP-G3)

Lamps: 1 x Cree\_XP-G3\_2x2\_(XPGDWT-B1-3C0-S4-0-01)\_516.459lm@250mA\_P=2.7885W\_I=0.25A

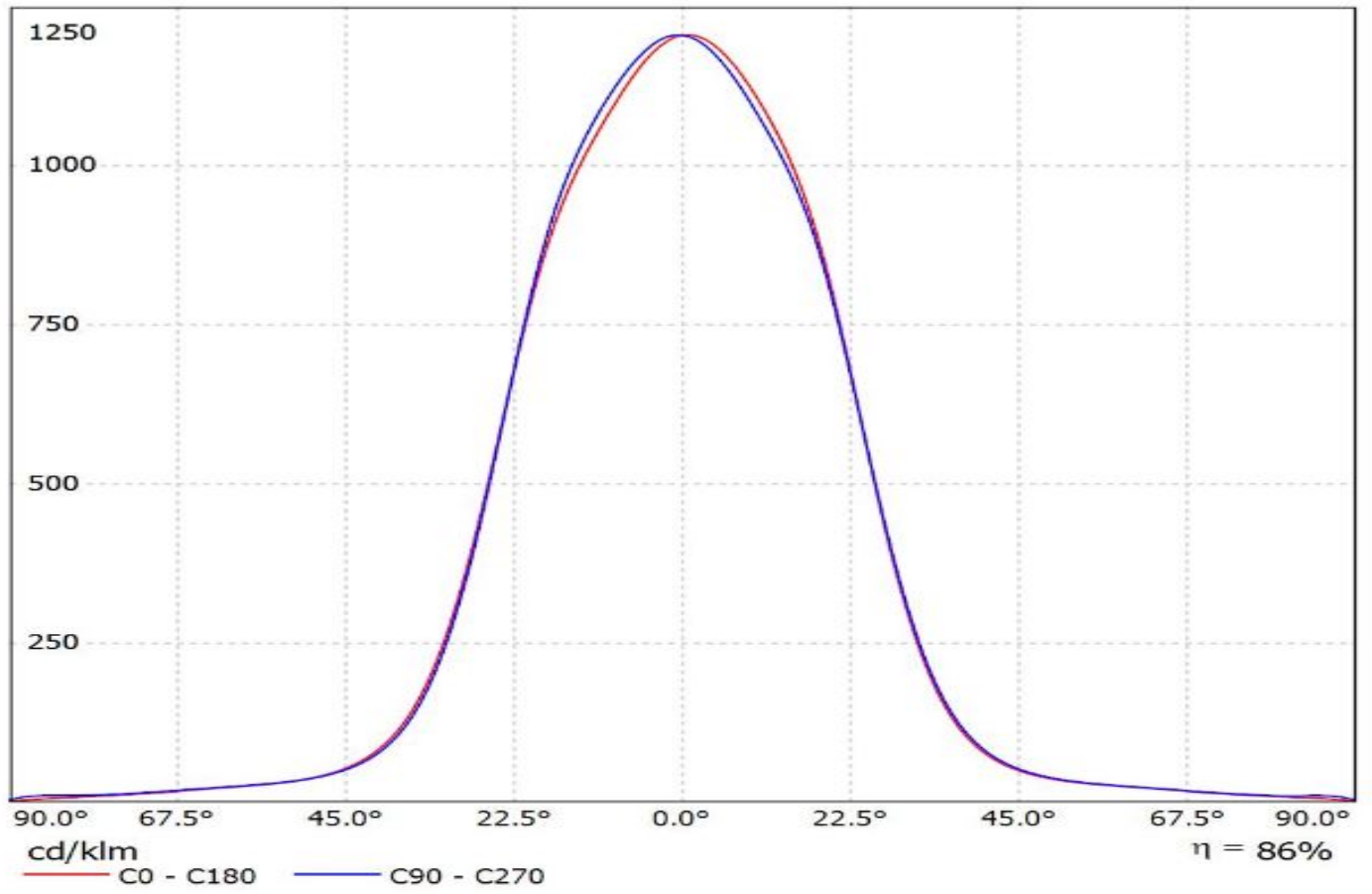



Luminaire: Ledil Oy C13605\_HB-2X2-RW\_(NCSxx19A) Efficiency=90%  
Lamps: 1 x Nichia NCSxx19A (NCSL119AT-H1) (229lm @ 250mA) CCT=2800K P=3.1W I=250mA

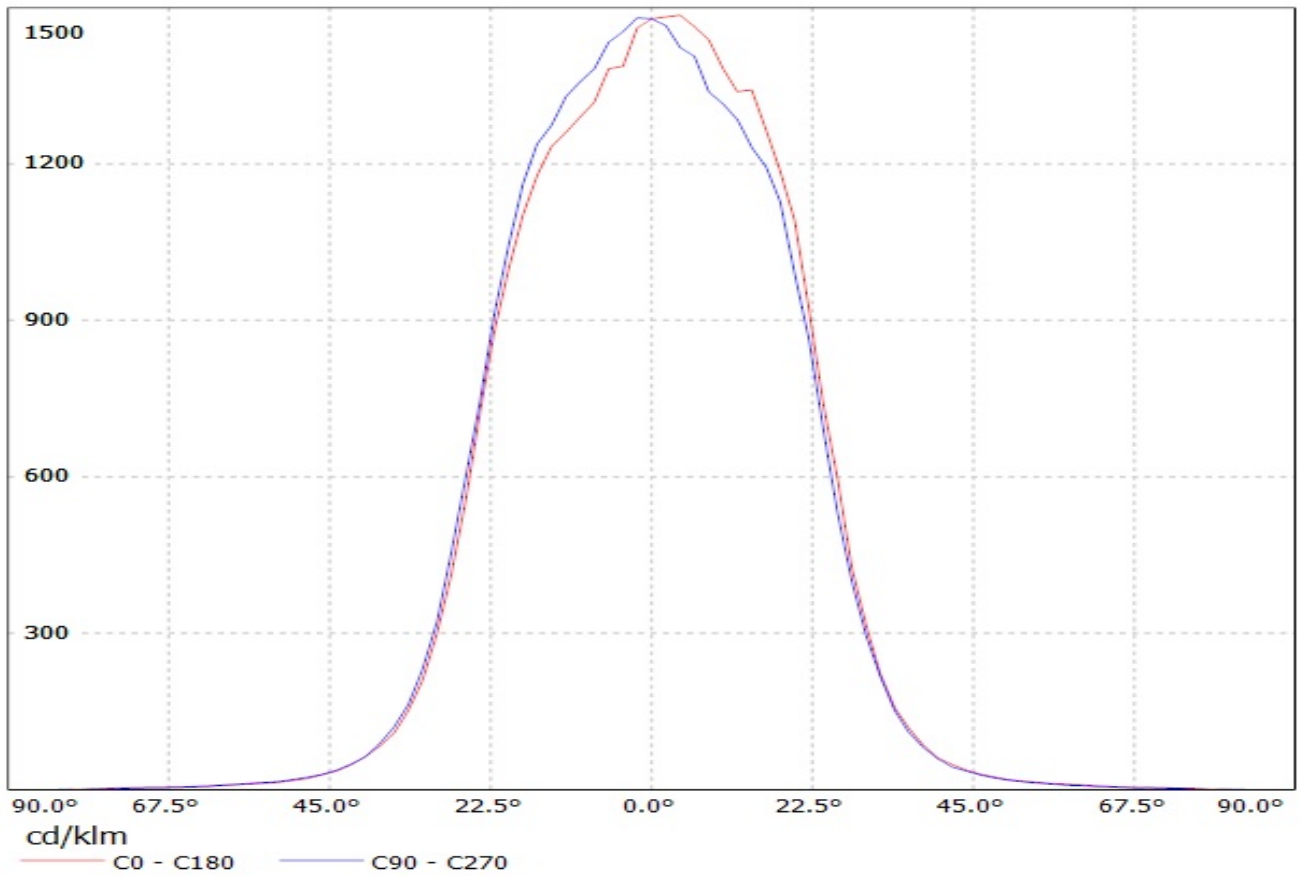

Luminaire: Ledil Oy C13605\_HB-2x2-RW\_(NVSxx19A) Efficiency=88%  
Lamps: 1 x Nichia NVSxx19A (NVS219AT) 382lm @ 250mA CCT=5290K P=2.9W I=250mA

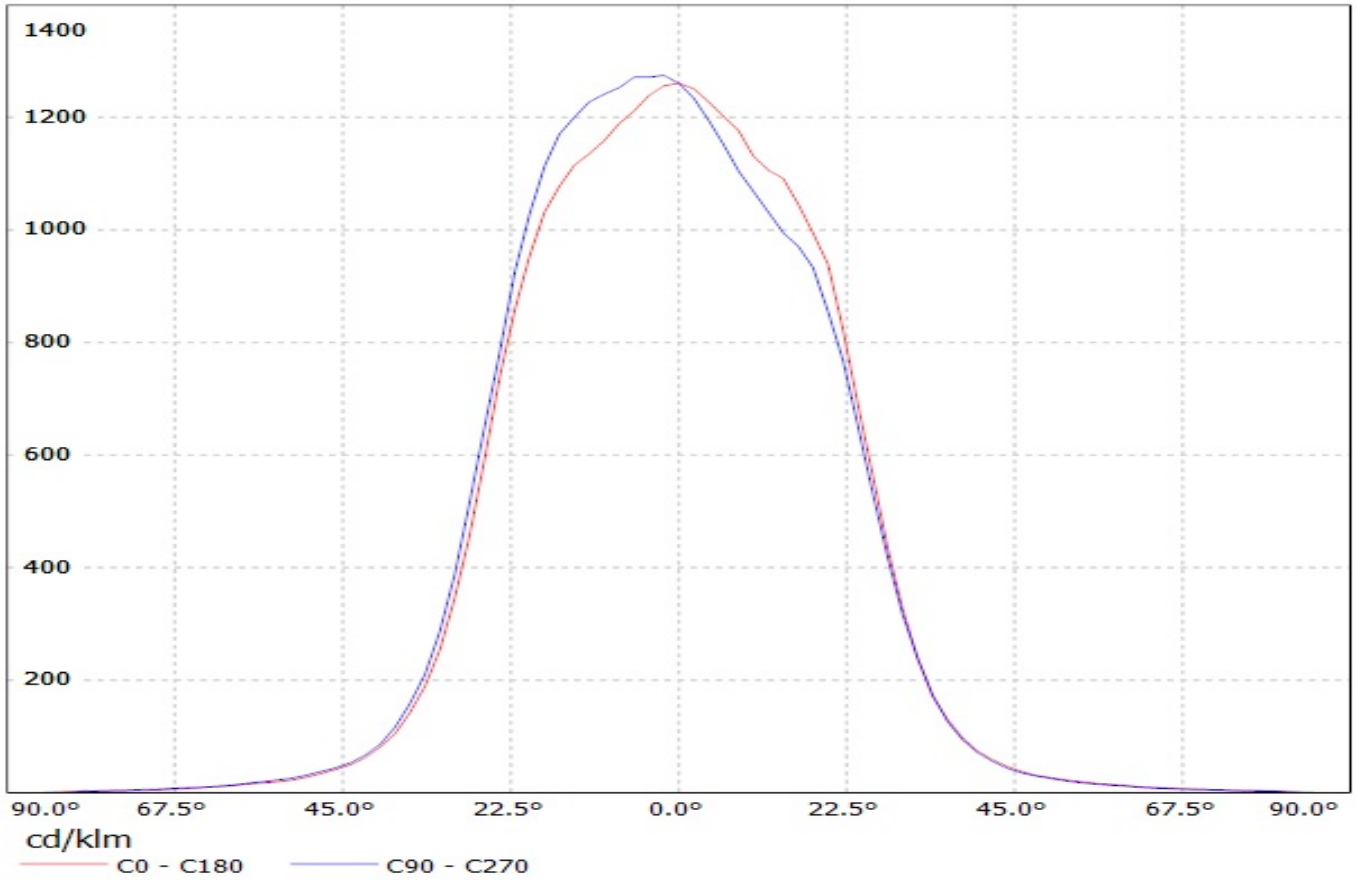

Luminaire: Ledil Oy C13605\_HB-2X2-RW\_(NVSxx19B) Efficiency=90%  
Lamps: 1 x Nichia NVSxx19B (NVSL219BE) 308lm @ 250mA CCT=3100K P=2.9W I=250mA

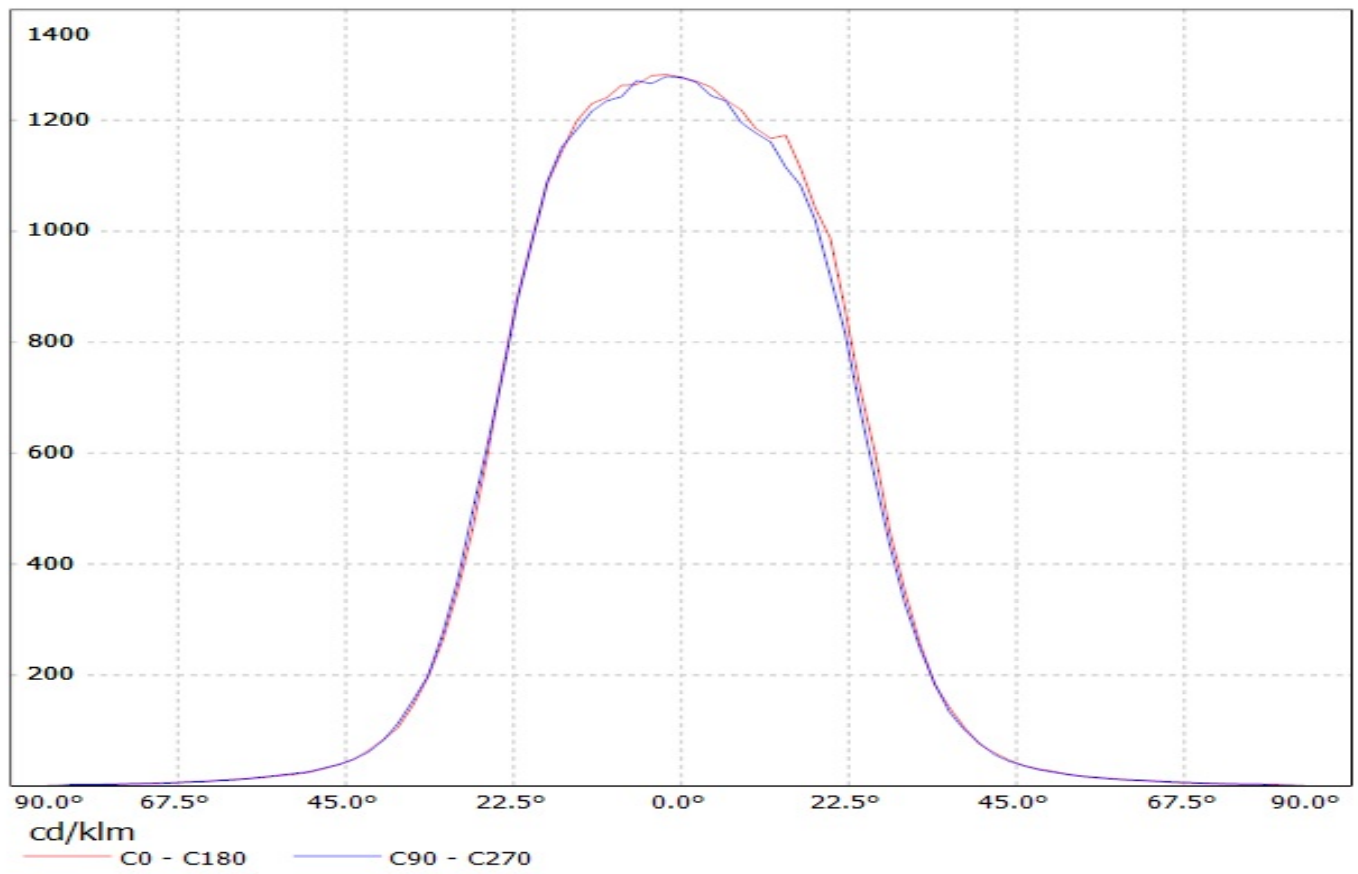

Luminaire: LEDiL Oy C13605\_HB-2X2-RW\_(E21A)  
Lamps: 1 x Nichia\_E21A\_2X2\_454.11lm@250mA\_P=2.81W\_I=0.250A

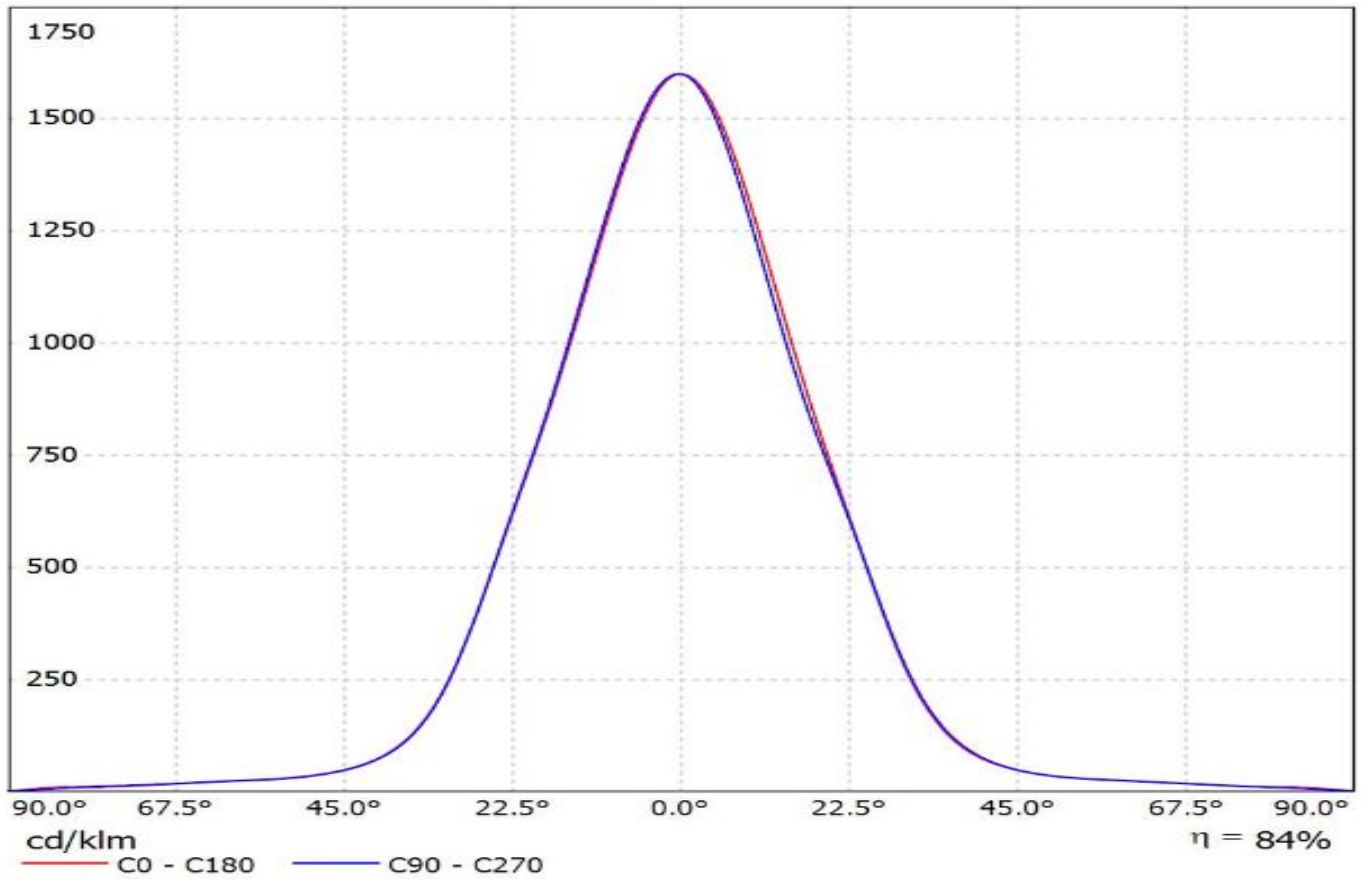

Luminaire: Ledil Oy C13605\_HB-2X2-RW\_(Oslon\_Square\_PC) Efficiency=90%  
Lamps: 1 x Osram Oslon Square PC (LCW-CQAR.PC-MSMU-5H71-1) 389lm @ 250mA CCT=6000K P=3.0W I=250mA

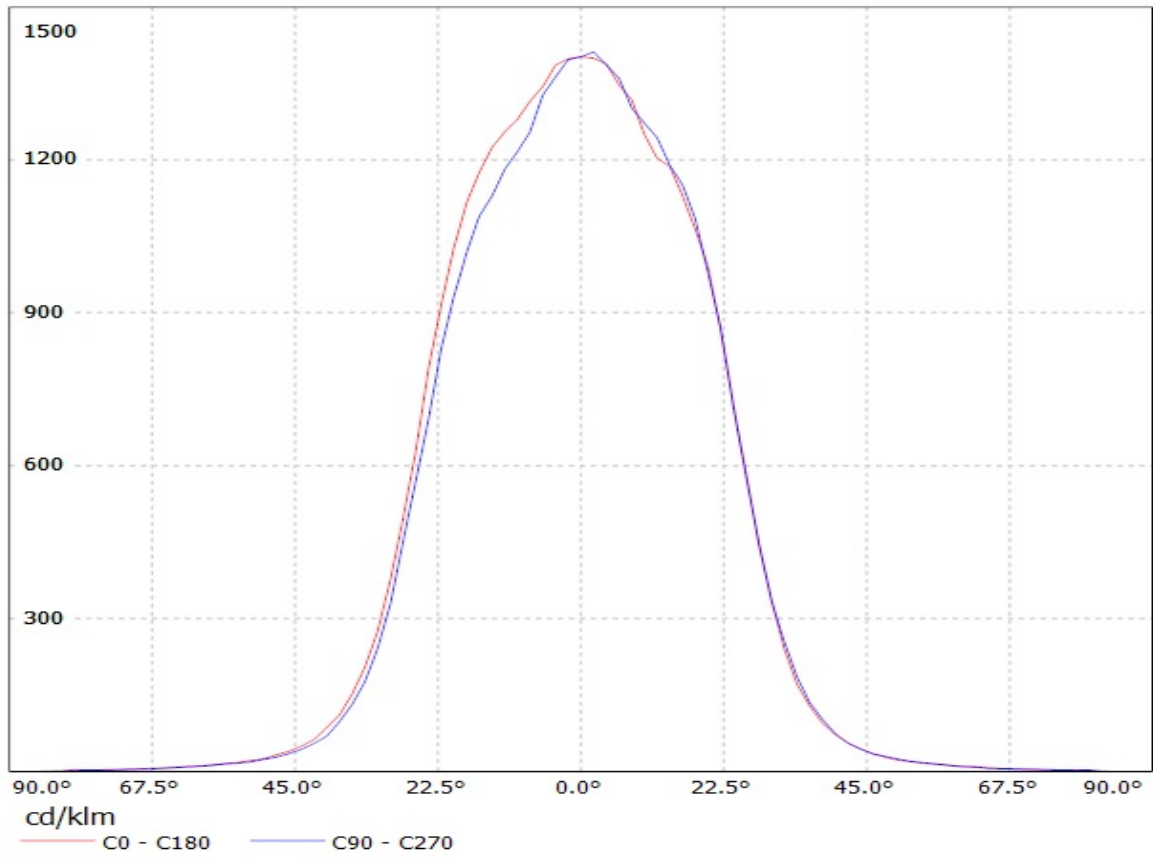

Luminaire: Ledil Oy C13605\_HB-2X2-RW\_(SSL\_80) Efficiency=90%  
Lamps: 1 x Osram Oslon SSL 80 (310lm @ 250mA) CCT=6800K P=3.2W I=250mA

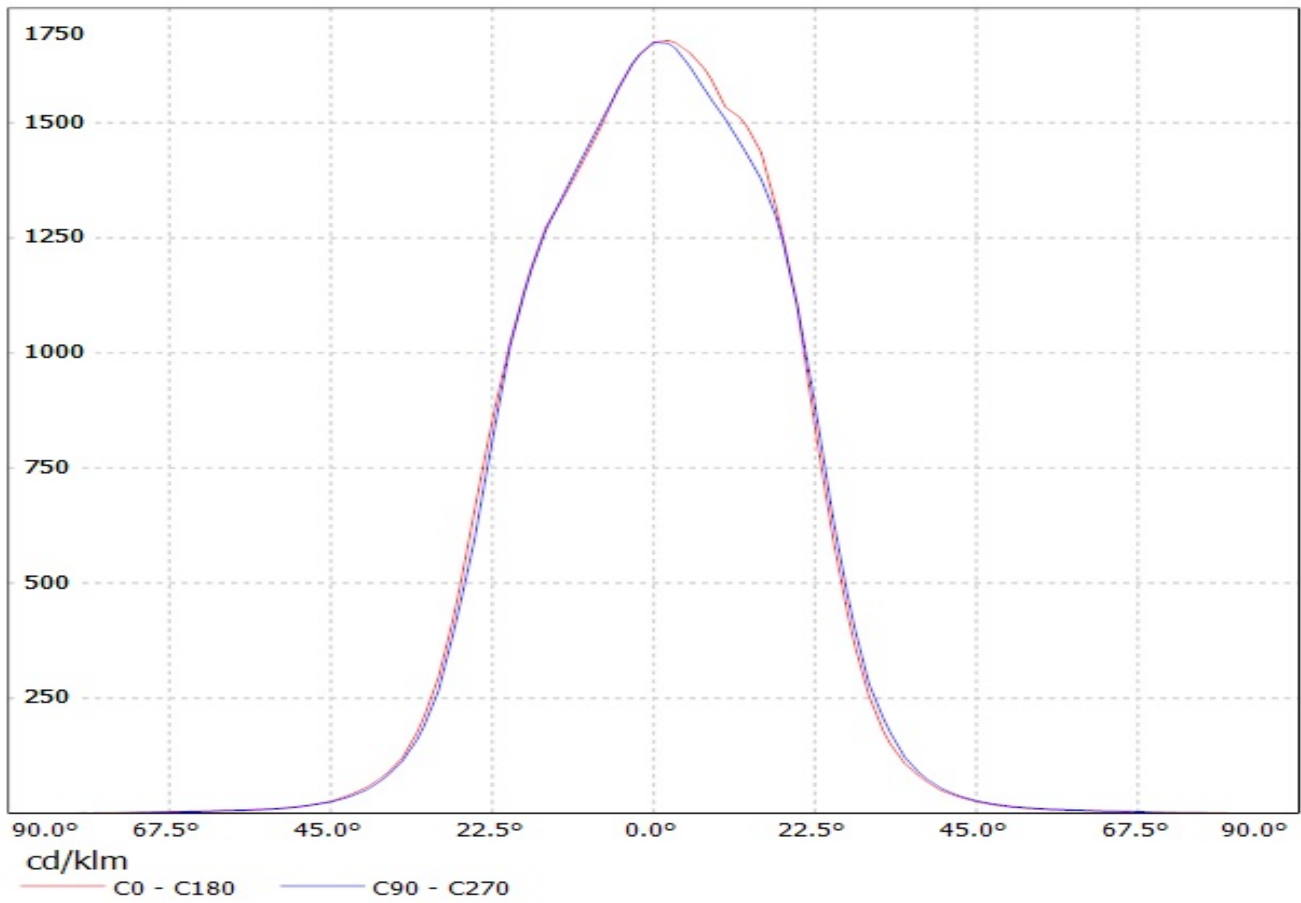

Luminaire: LEDiL Oy  
Lamps: 1 x C13605-HB-2x2-RW\_(SQ\_Gen3)

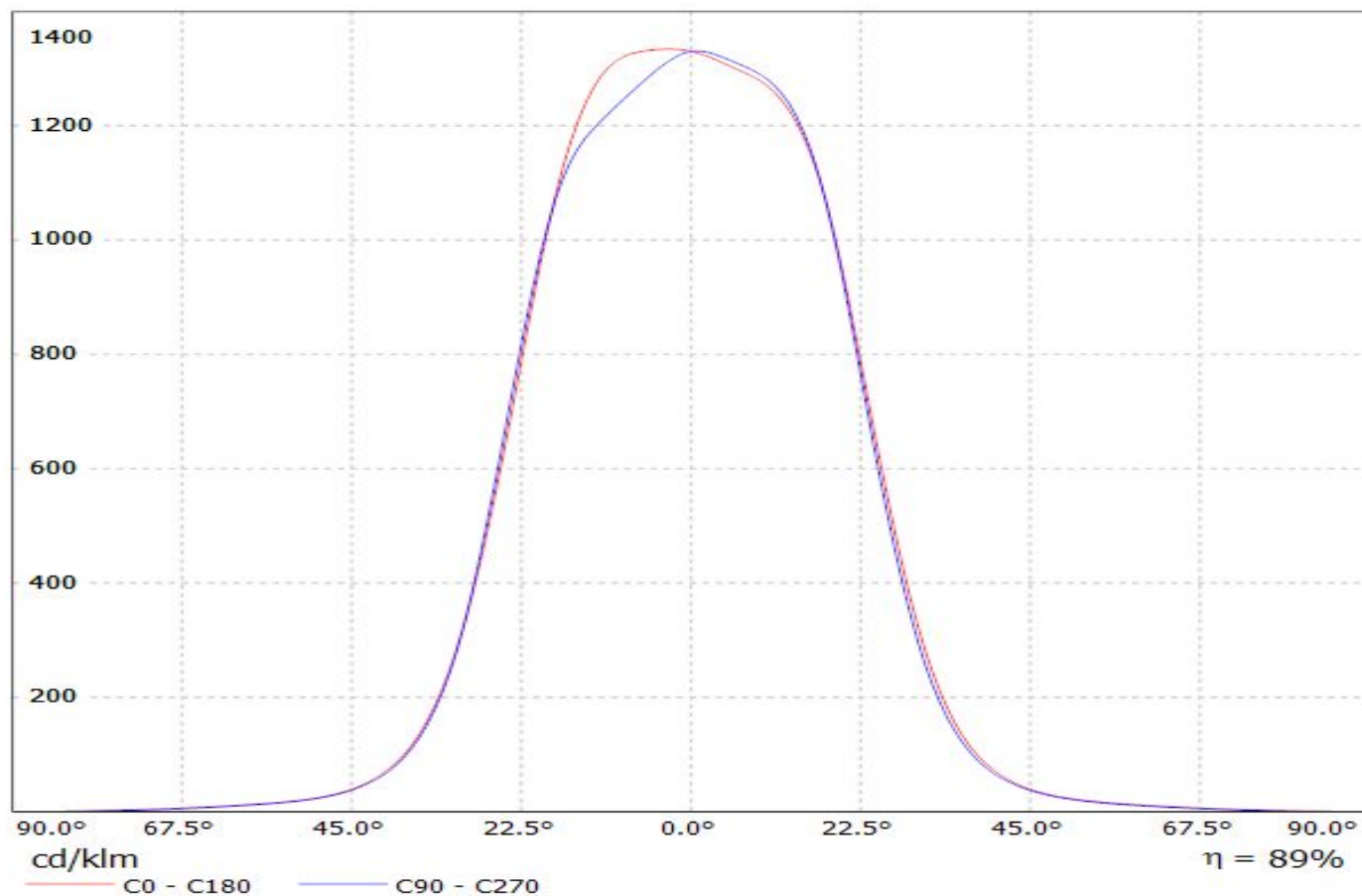

Luminaire: LEDiL Oy C13605\_HB-2X2-RW\_(LH351Z) Eff.90.2%  
Lamps: 1 x SAMSUNG\_LH351Z\_2x2\_359.49lm@250mA\_P=2.86371W\_I=249.8mA

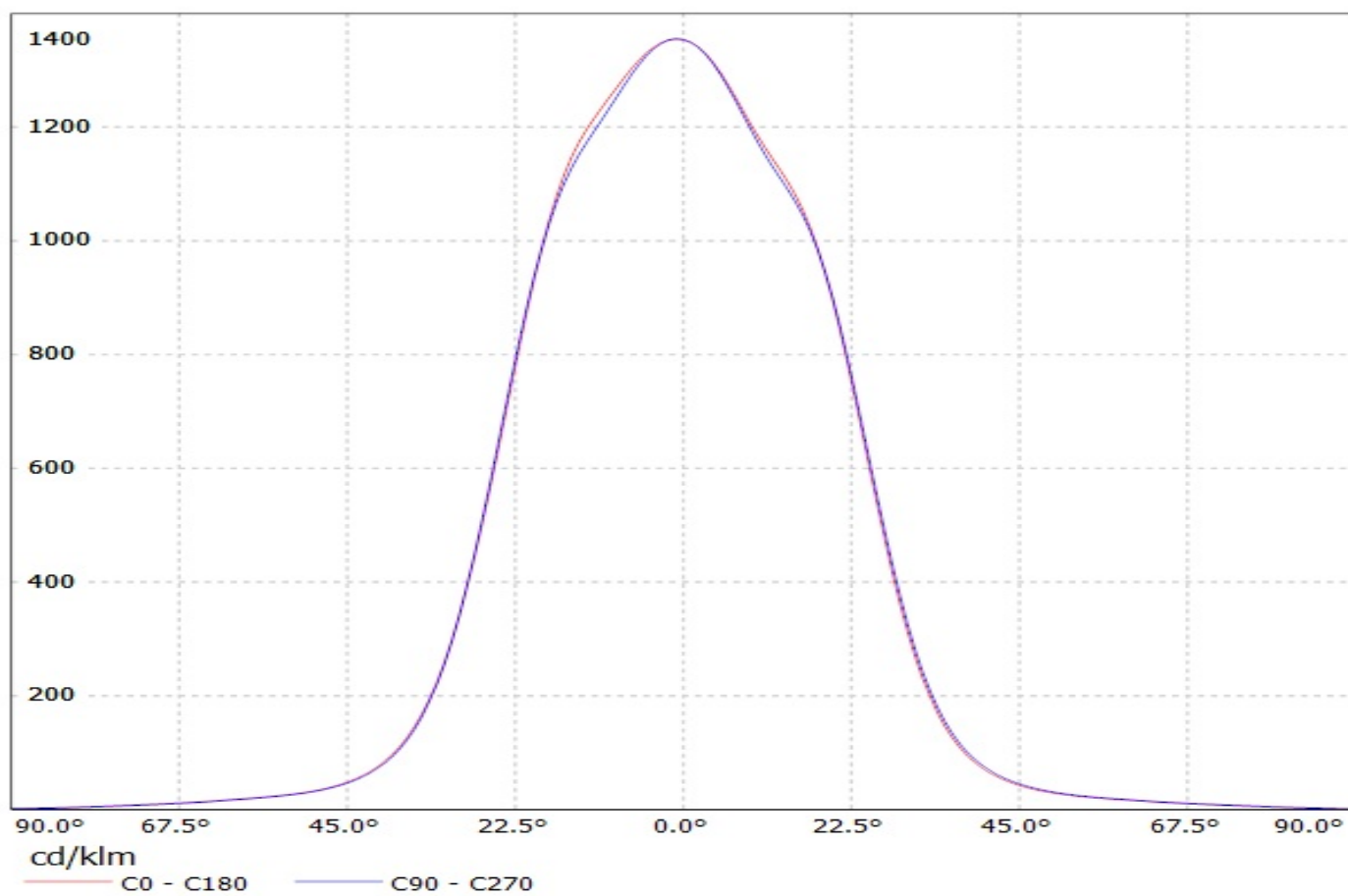



Luminaire: LEDil Oy C13605\_HB-2x2-RW\_(Z5M1) Efficiency=90%  
Lamps: 1 x Seoul (SZ5-M1-WN-C8) 379lm @ 250mA CCT=4600K P=2.9W I=250mA

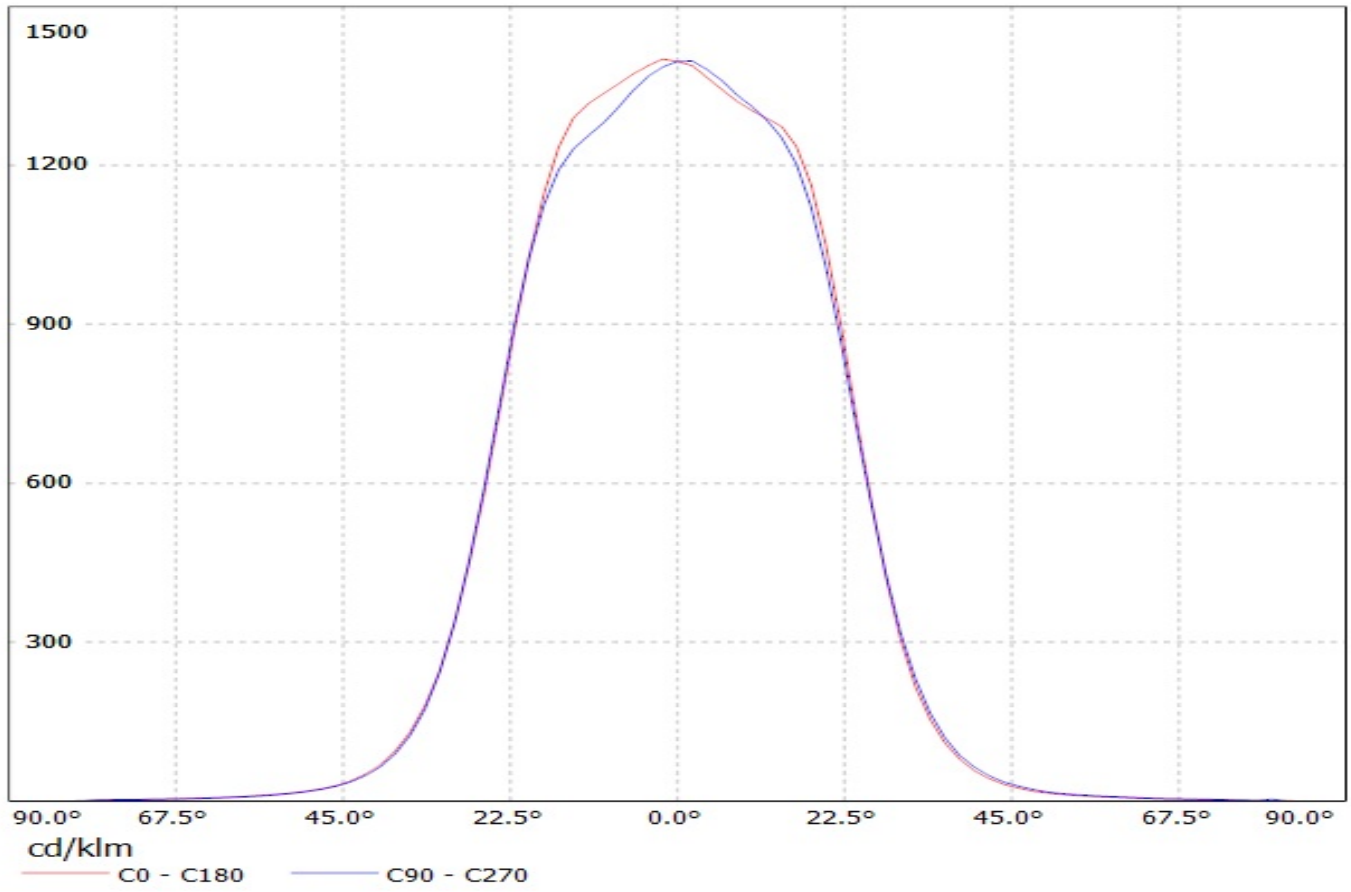

Luminaire: LEDiL Oy C13605\_HB-2X2-RW\_(WICOP2\_Z8Y15)

Lamps: 1 x SEOUL\_WICOP2\_Z8Y15\_336.842lm@250mA\_P=2.9399W\_I=0.250A

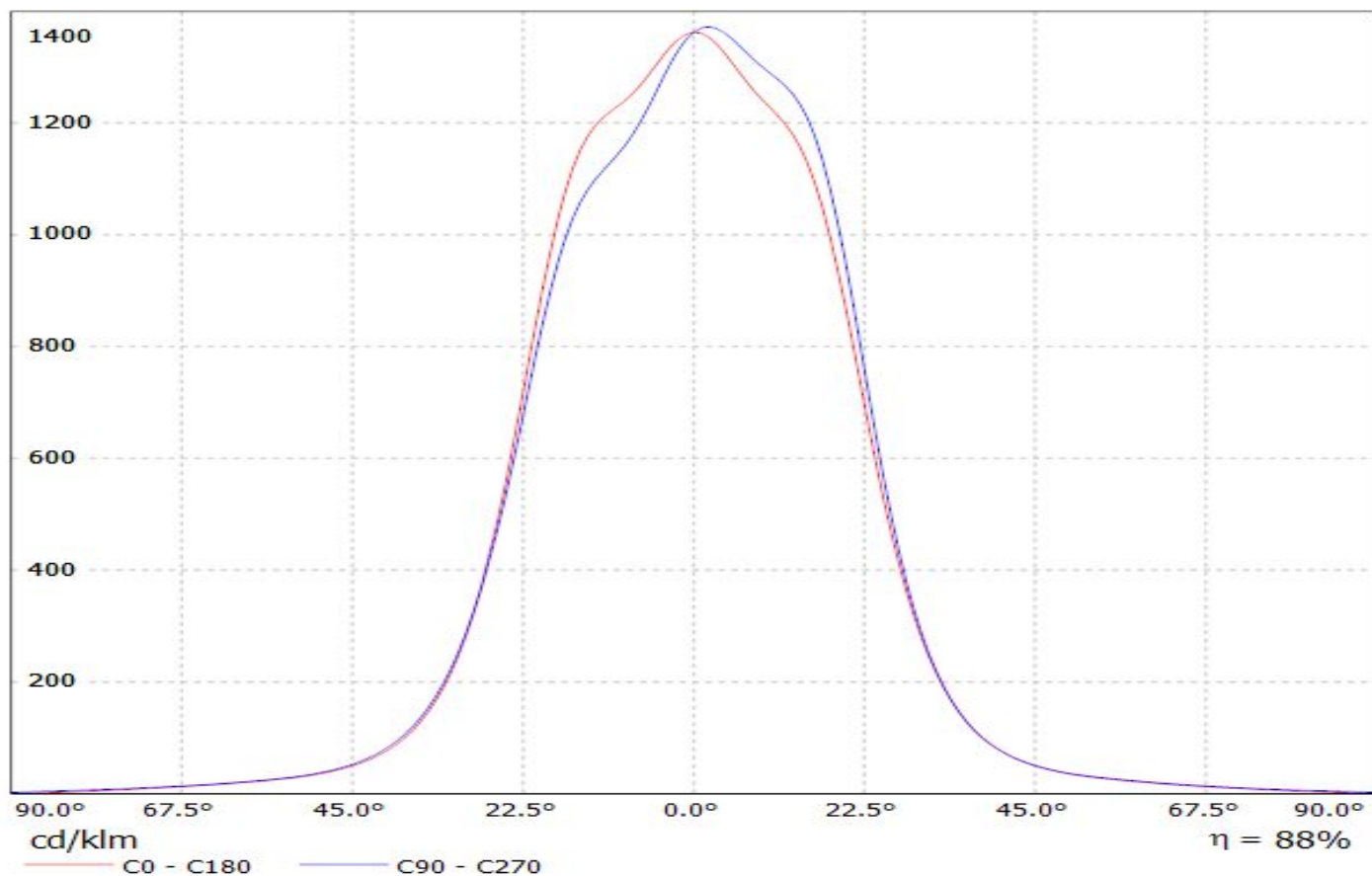

Luminaire: LEDiL Oy C13605\_HB-2X2-RW\_(WICOP2\_Z8Y19)

Lamps: 1 x SEOUL\_WICOP2\_Z8Y19\_450.124lm@250mA\_P=2.8579W\_I=0.250A

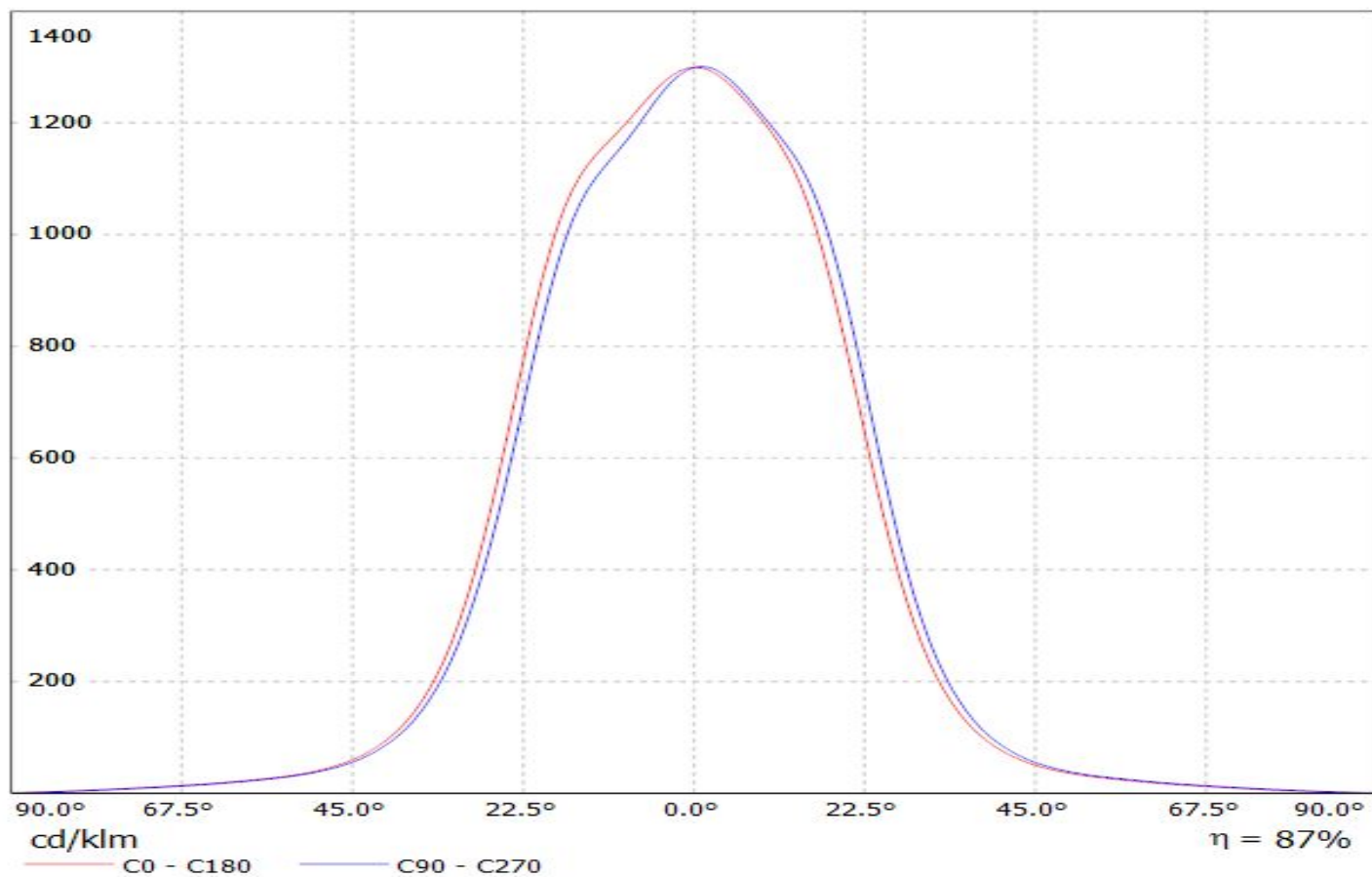

# Ledil C13605\_HB-2X2-RW\_(TL1L4) / LDC (Linear)

Luminaire: Ledil C13605\_HB-2X2-RW\_(TL1L4)

Lamps: 1 x Toshiba\_TL1L4\_2x2\_(TL1L4-DW0)\_472.639lm@250mA\_CCT=6500K\_P=2.9W\_I=0.25A

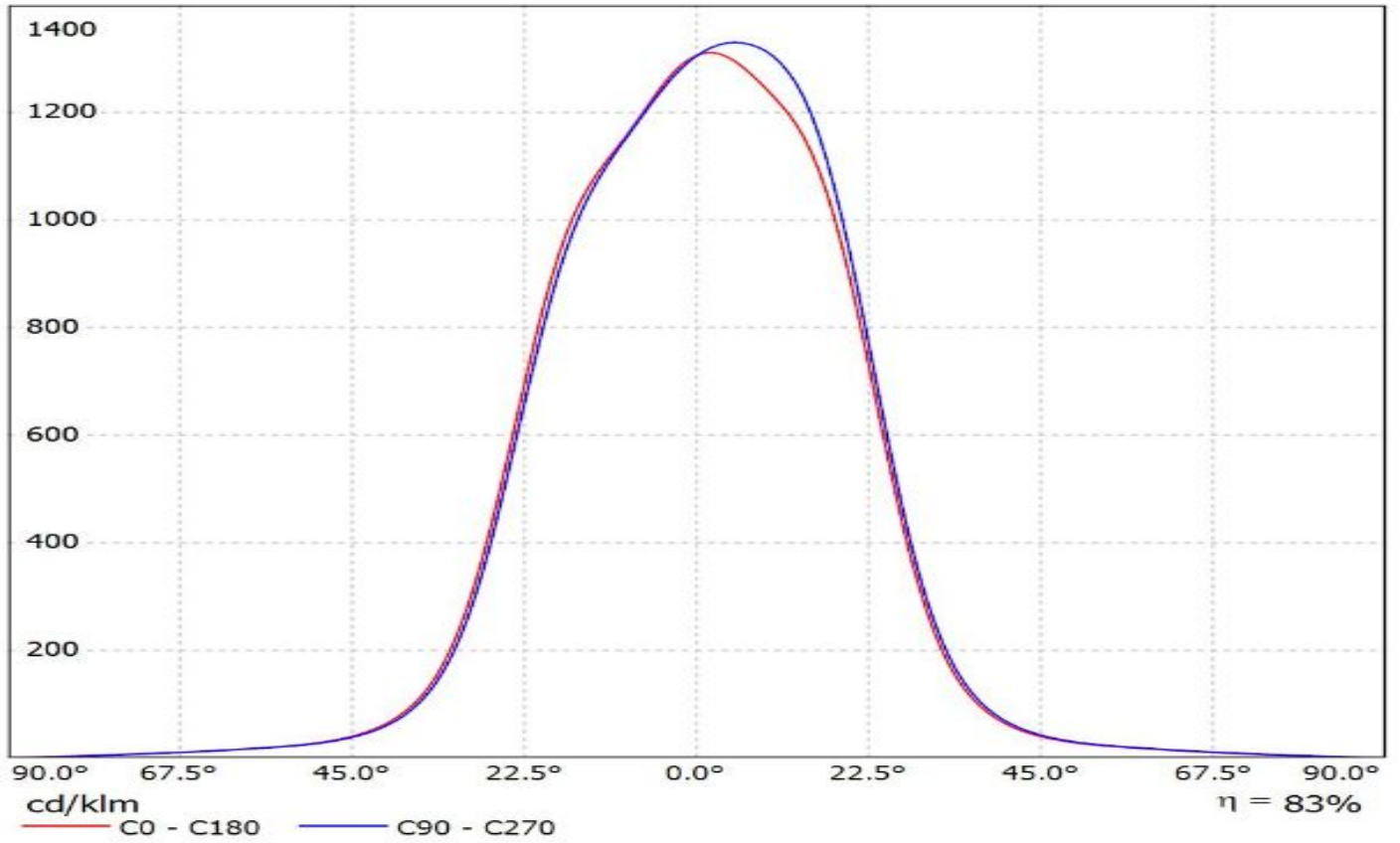

Luminaire: LEDiL Oy C13605\_HB-2X2-RW\_(Tridonic\_Module\_RLE\_G1)  
Lamps: 1 x Tridonic\_Module\_RLE\_G1\_4576.03lm@700mA\_P=32.0681W\_I=0.700A

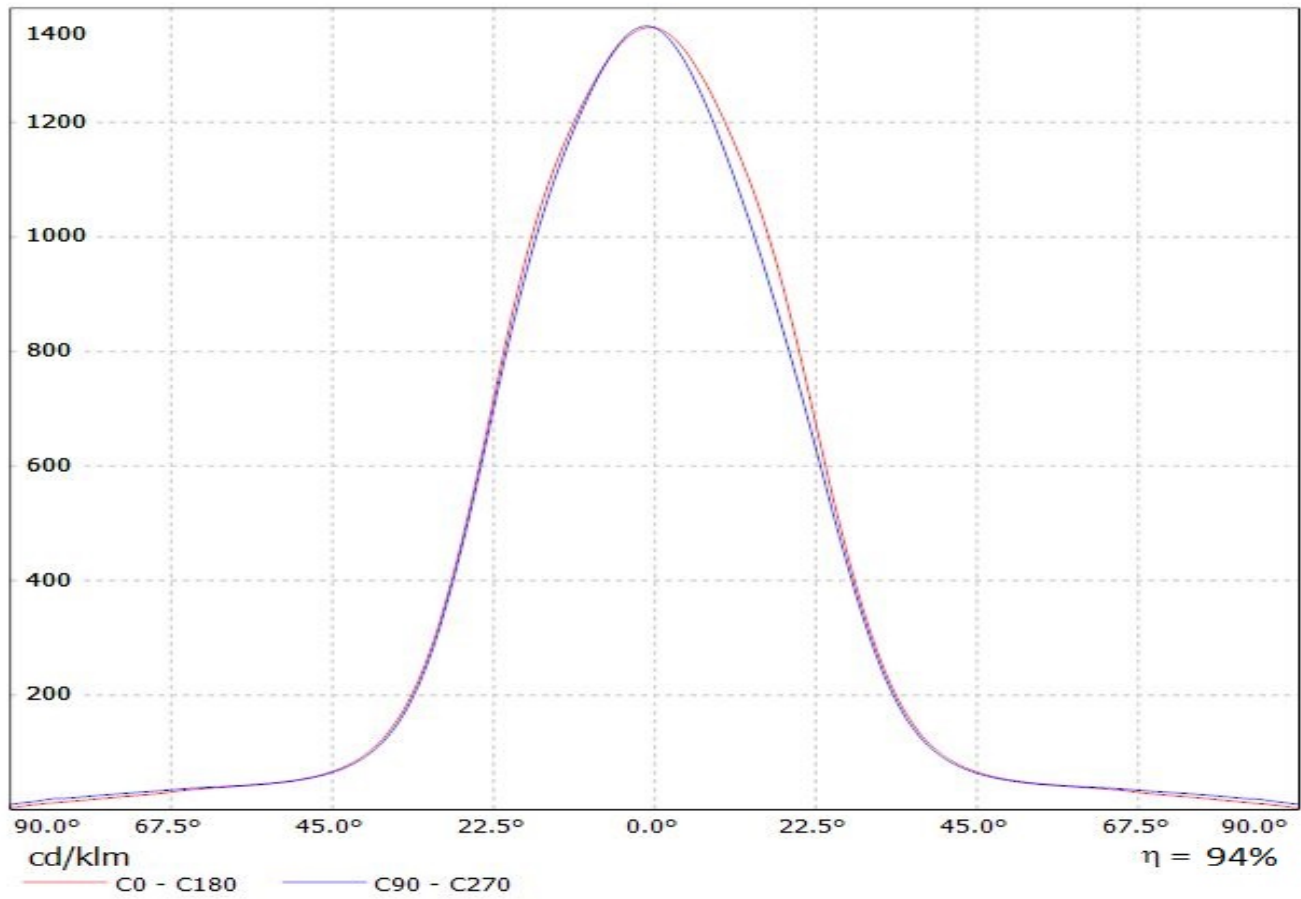

Luminaire: LEDiL Oy C13605\_HB-2X2-RW\_(Tridonic\_Module\_RLE\_G1)  
Lamps: 1 x Tridonic\_Module\_RLE\_G1\_4576.03lm@700mA\_P=32.0681W\_I=0.700A

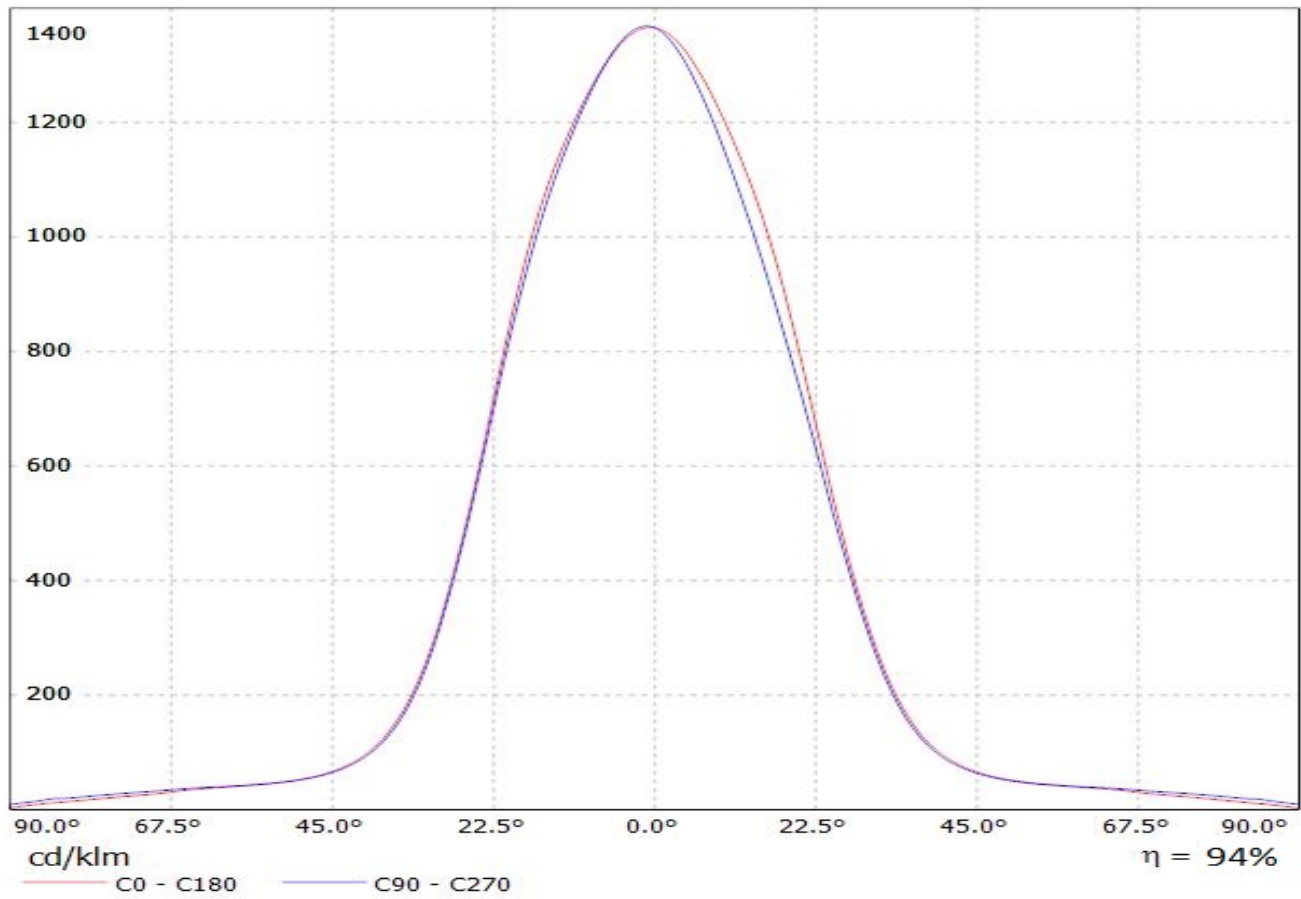

Luminaire: LEDiL Oy C13605\_HB-2X2-RW\_(Tridonic\_Module\_RLE\_G1)  
Lamps: 1 x Tridonic\_Module\_RLE\_G1\_2288lm@700mA\_P=16W\_I=0.700A

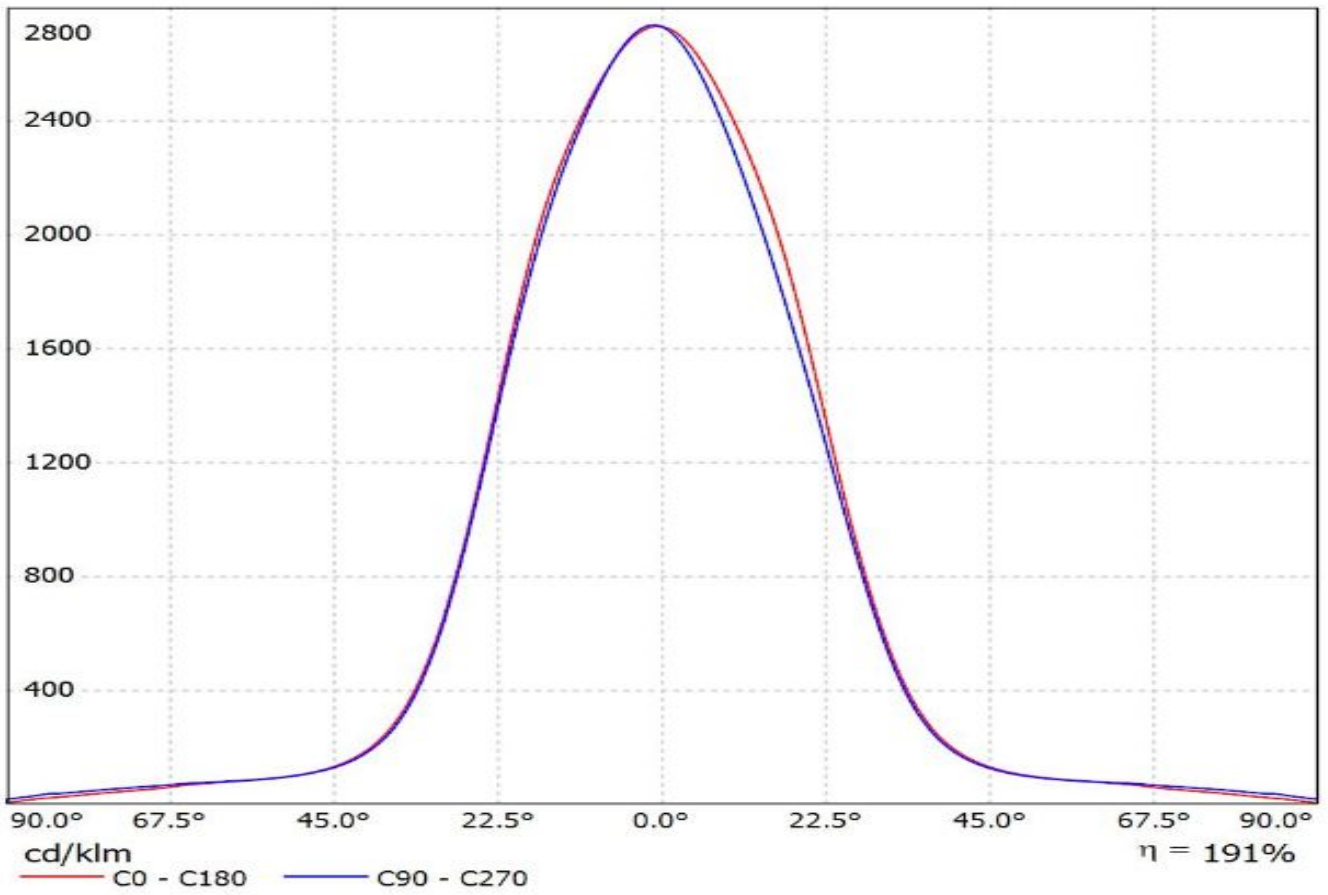

Luminaire: LEDiL Oy C13605\_HB-2X2-RW\_(Tridonic\_Module\_RLE\_G1)  
Lamps: 1 x Tridonic\_Module\_RLE\_G1\_2288lm@700mA\_P=16W\_I=0.700A

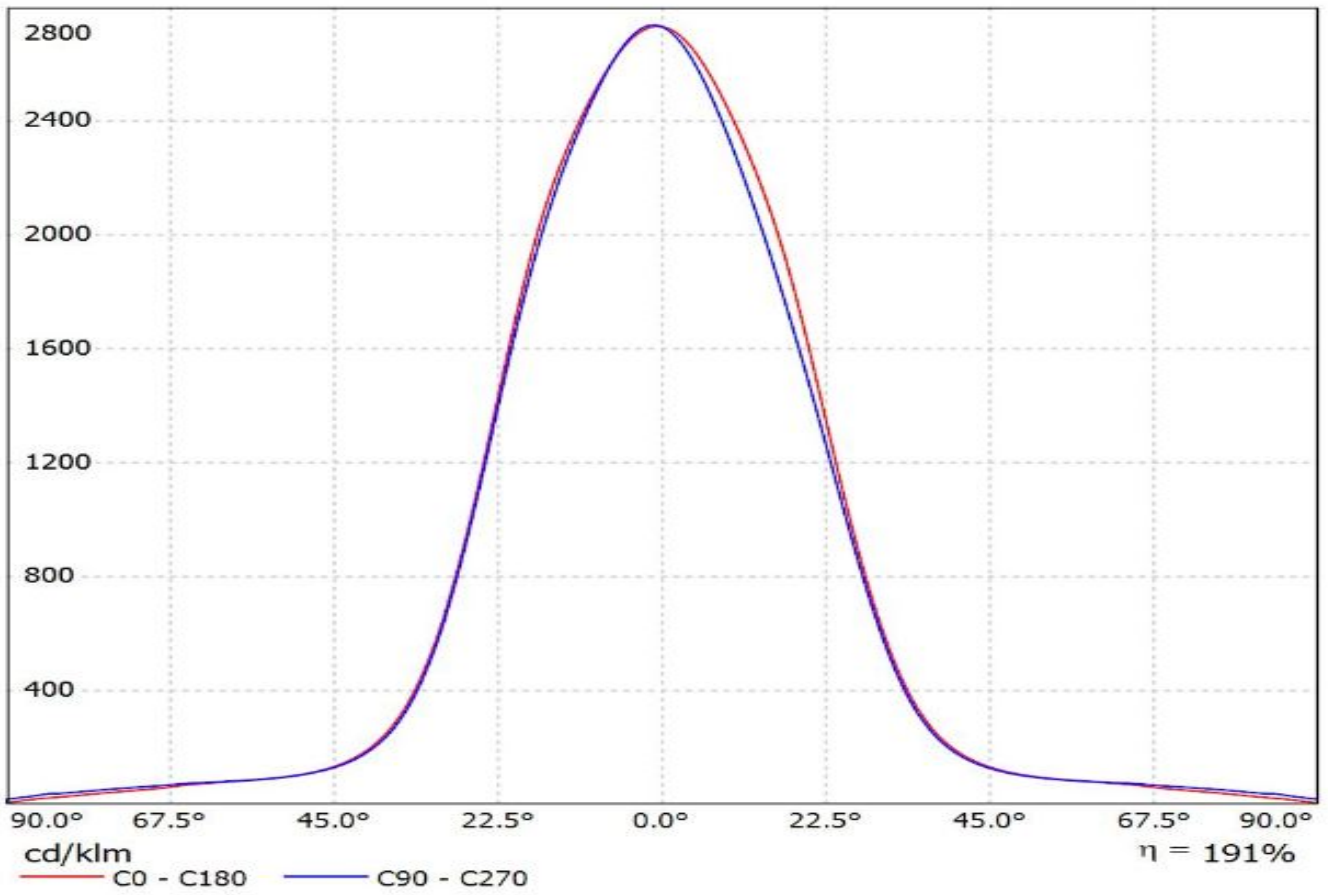



Luminaire: Ledil Oy C13605\_HB-2X2-RW (Cree XT-E 390lm @ 250mA) Efficiency=89%  
Lamps: 1 x Cree XT-E 390lm @ 250mA CCT=5717K P=3W I=250mA

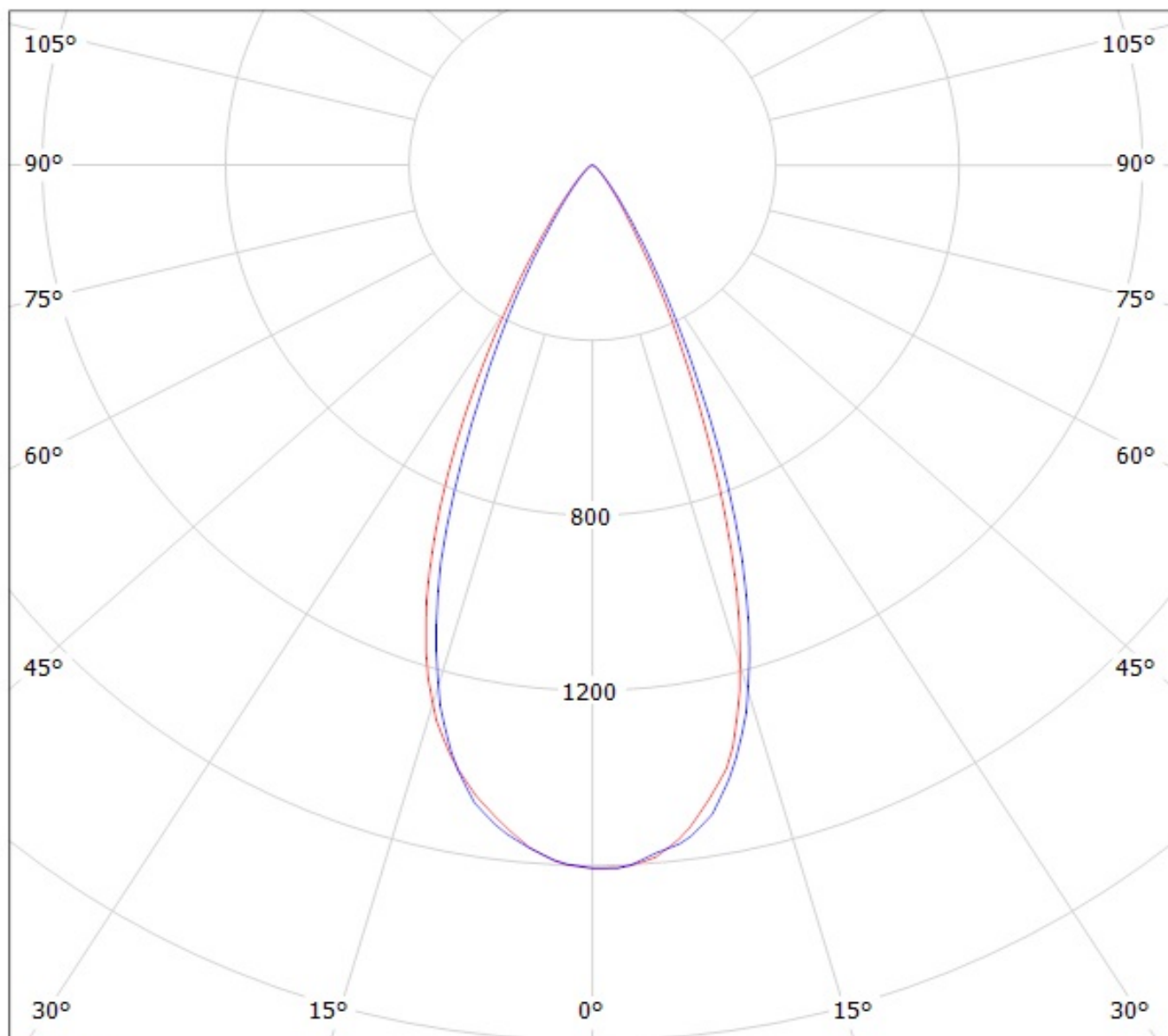

cd/klm

— C0 - C180

— C90 - C270

Luminaire: Ledil Oy C13605\_HB-2X2-RW (Cree XP-G2 408lm Im @ 250mA) Efficiency=91%  
Lamps: 1 x Cree XP-G2 408lm Im @ 250mA CCT=7181K P=3W I=250mA

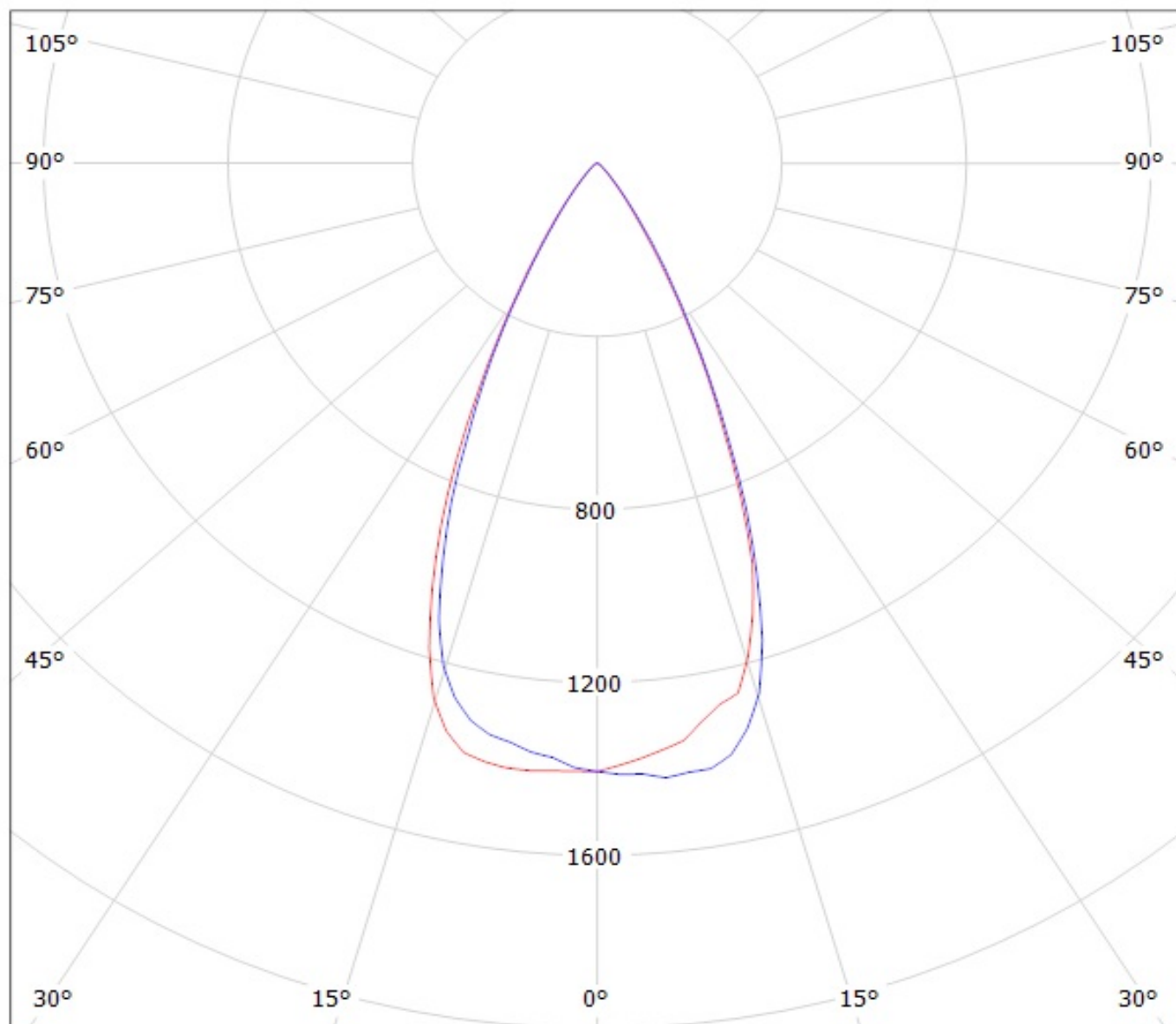

cd/klm

— C0 - C180

— C90 - C270

Luminaire: Ledil Oy C13605\_HB-2X2-RW\_(XP-G) Efficiency=89%  
Lamps: 1 x Cree XP-G (254lm @ 250mA) CCT=3300K P=2.9W I=250mA

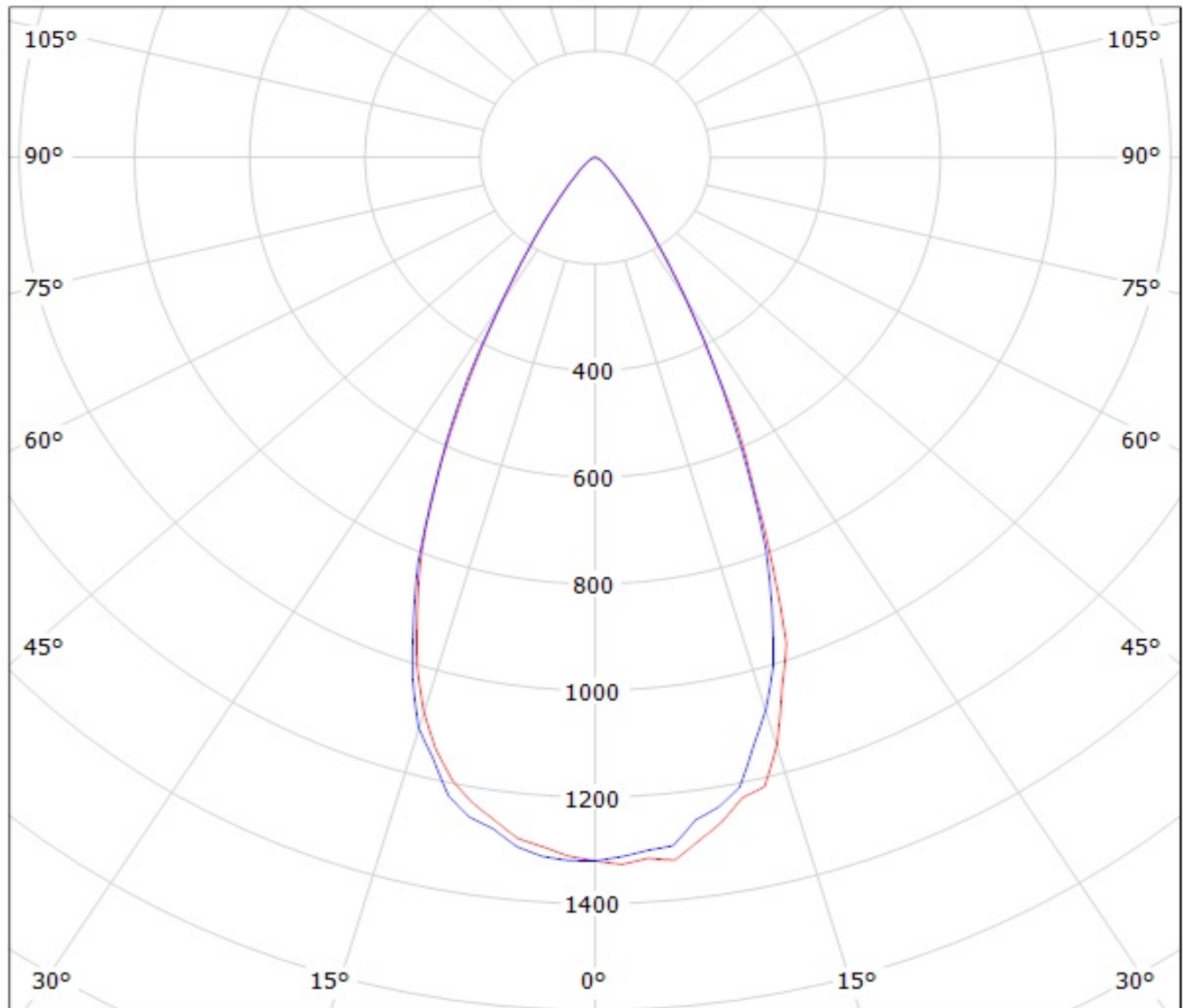

cd/klm

— C0 - C180

— C90 - C270

Luminaire: Ledil Oy C13605\_HB-2x2-RW\_(XP-E) Efficiency=89%  
Lamps: 1 x Cree XP-E (XPEWHT-L1-3C0-W5-0-06) 302lm @ 250mA CCT=5400K P=3.1W I=250mA

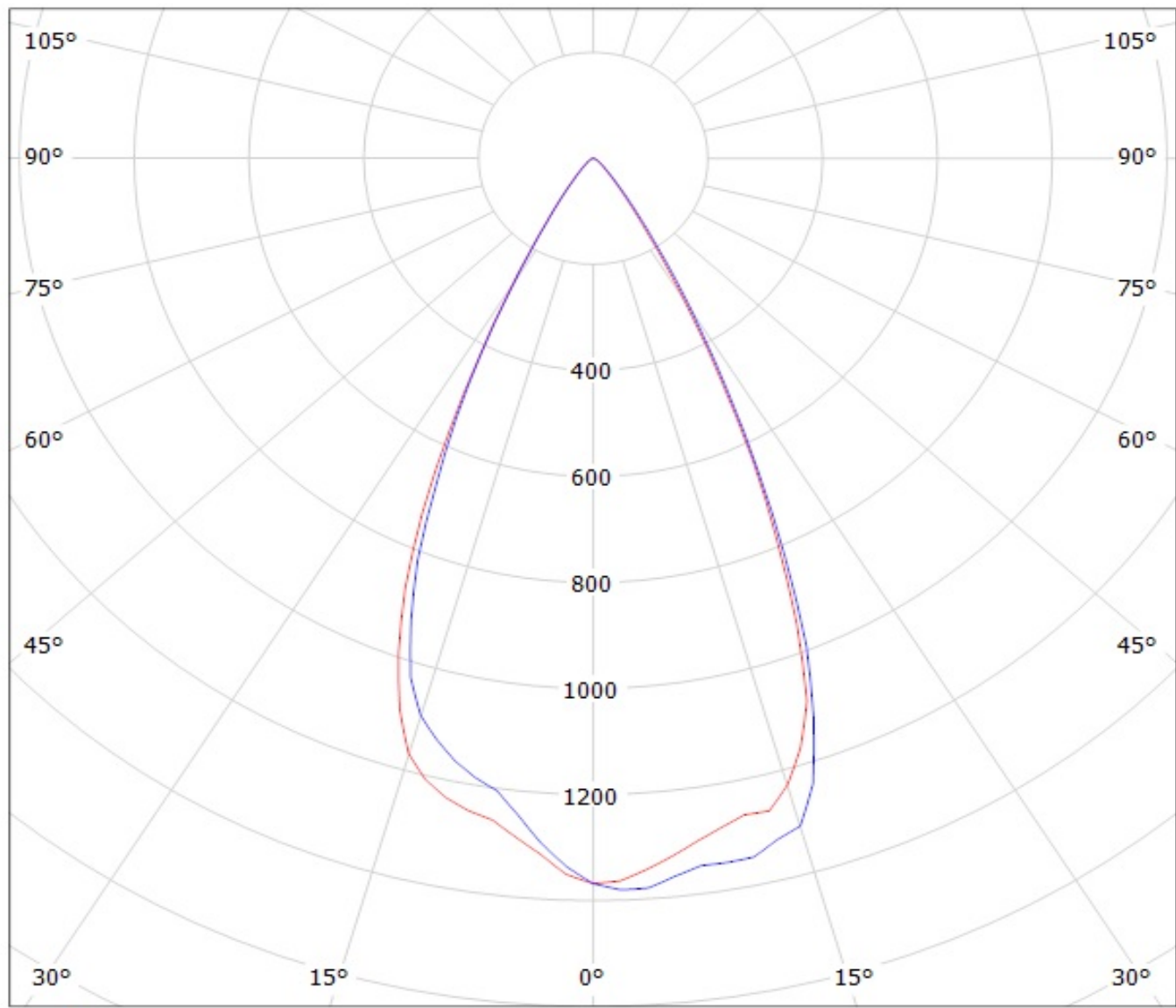

cd/klm  
— C0 - C180    — C90 - C270

Luminaire: Ledil Oy C13605\_HB-2X2-RW\_(XB-D) Efficiency=88%  
Lamps: 1 x Cree XB-D (365lm @ 250mA) CCT=6800K P=3.1W I=250mA

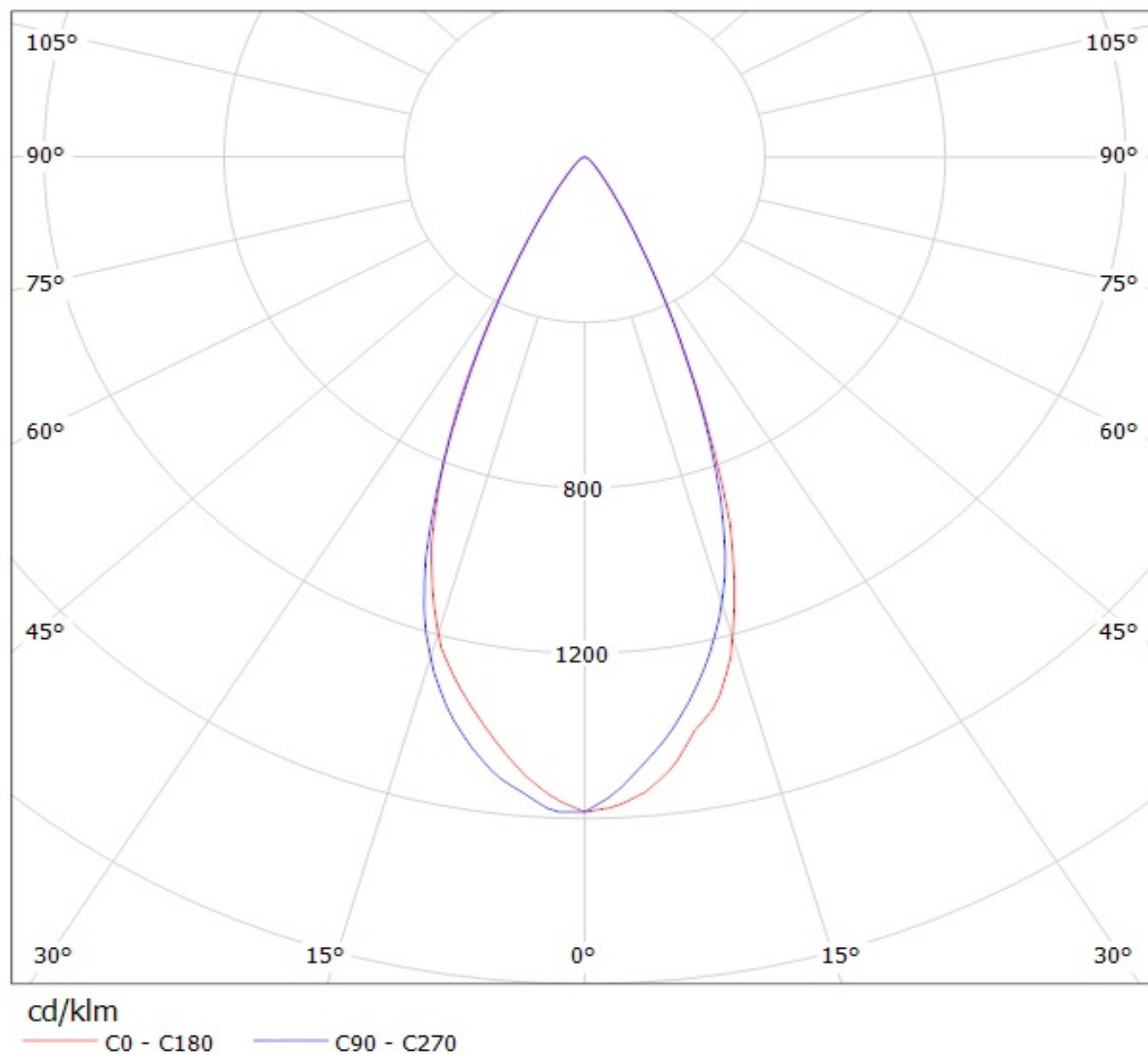

Luminaire: Ledil C13605\_HB-2x2-RW\_(XP-G3)

Lamps: 1 x Cree\_XP-G3\_2x2\_(XPGDWT-B1-3C0-S4-0-01)\_516.459lm@250mA\_P=2.7885W\_I=0.25A

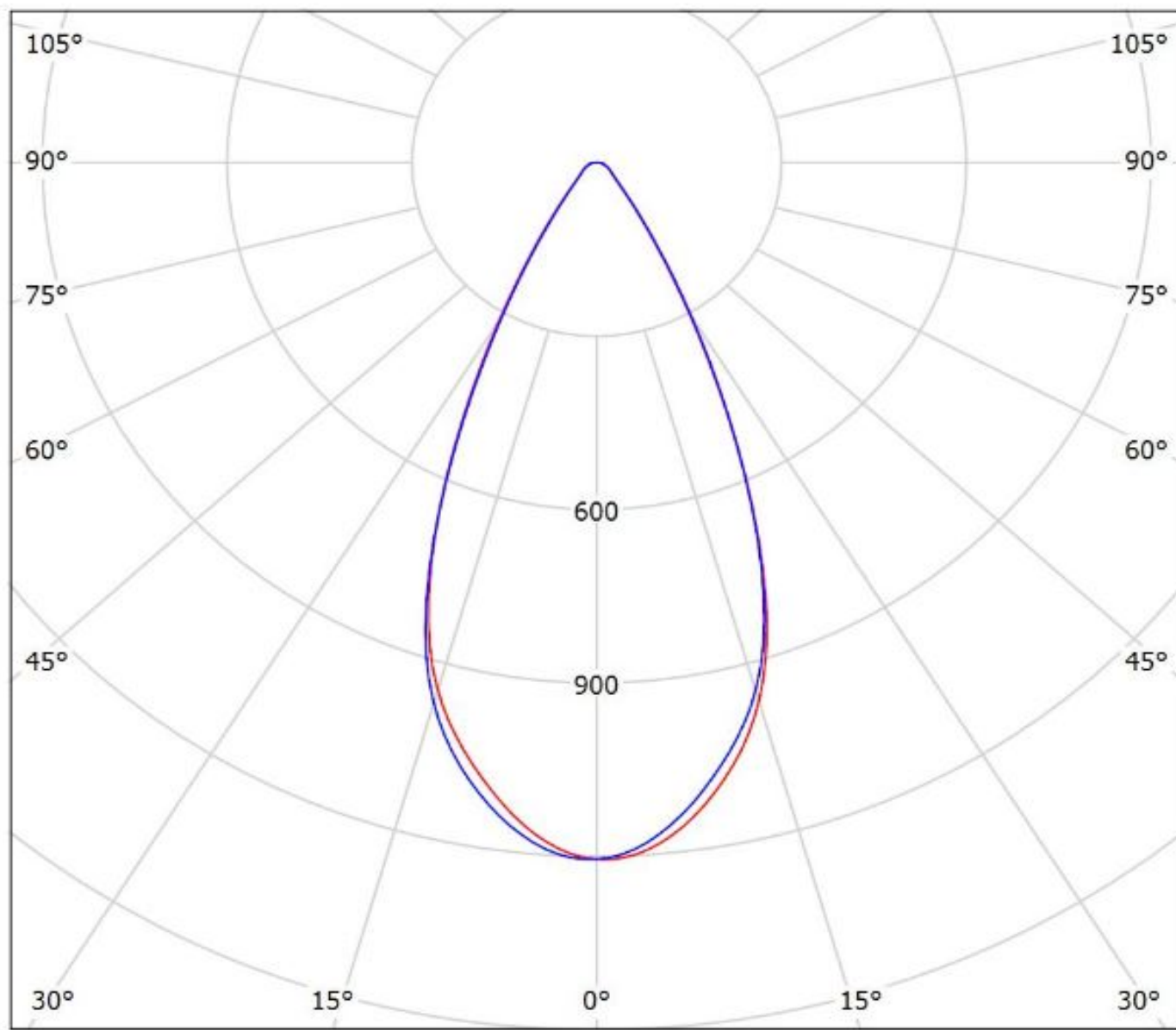

cd/klm

— C0 - C180 — C90 - C270

$\eta = 86\%$

Luminaire: Ledil Oy C13605\_HB-2X2-RW\_(NCSxx19A) Efficiency=90%  
Lamps: 1 x Nichia NCSxx19A (NCSL119AT-H1) (229lm @ 250mA) CCT=2800K P=3.1W I=250mA

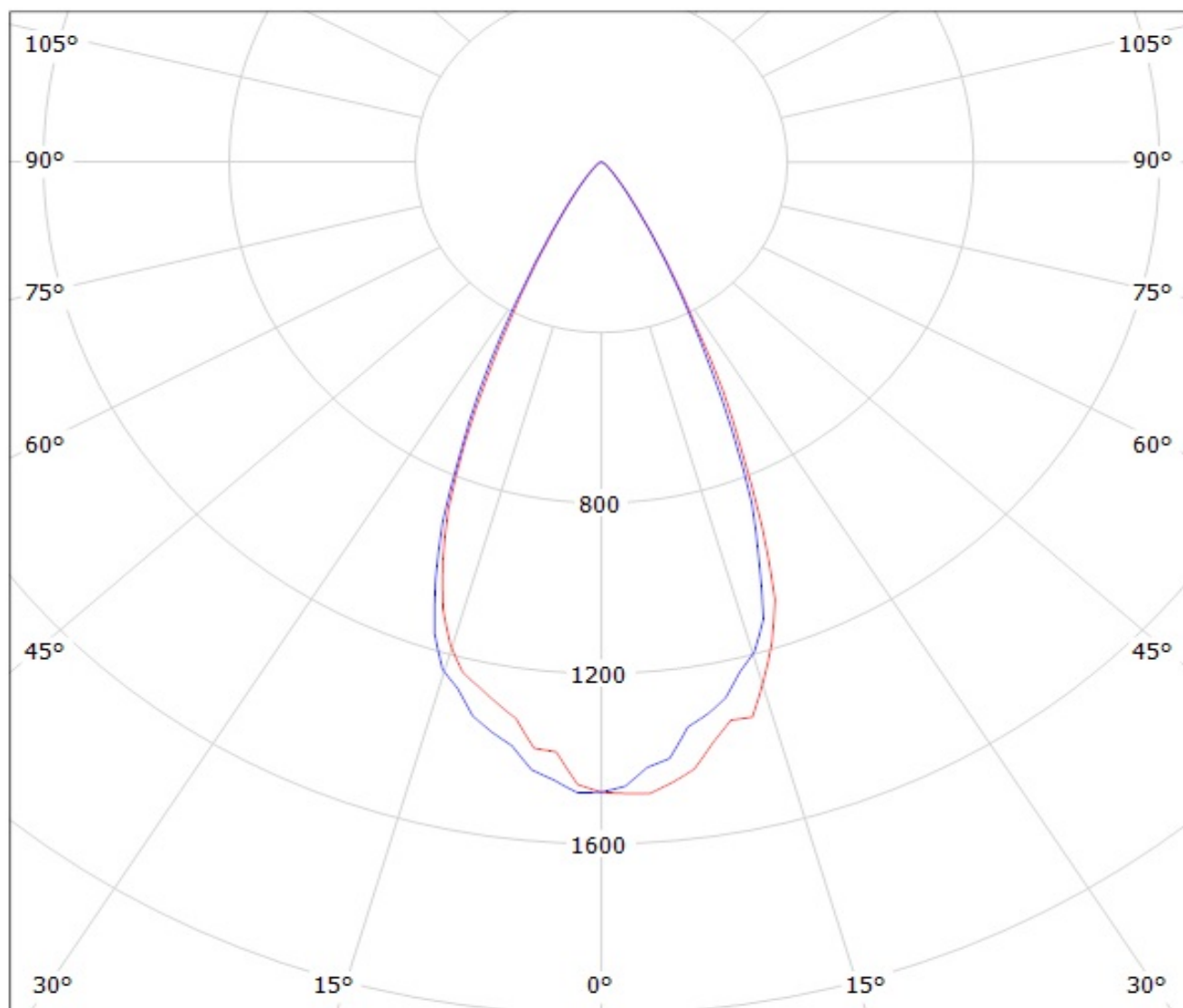

cd/klm

— C0 - C180    — C90 - C270



Luminaire: Ledil Oy C13605\_HB-2x2-RW\_(NVSxx19A) Efficiency=88%  
Lamps: 1 x Nichia NVSxx19A (NVS219AT) 382lm @ 250mA CCT=5290K P=2.9W I=250mA

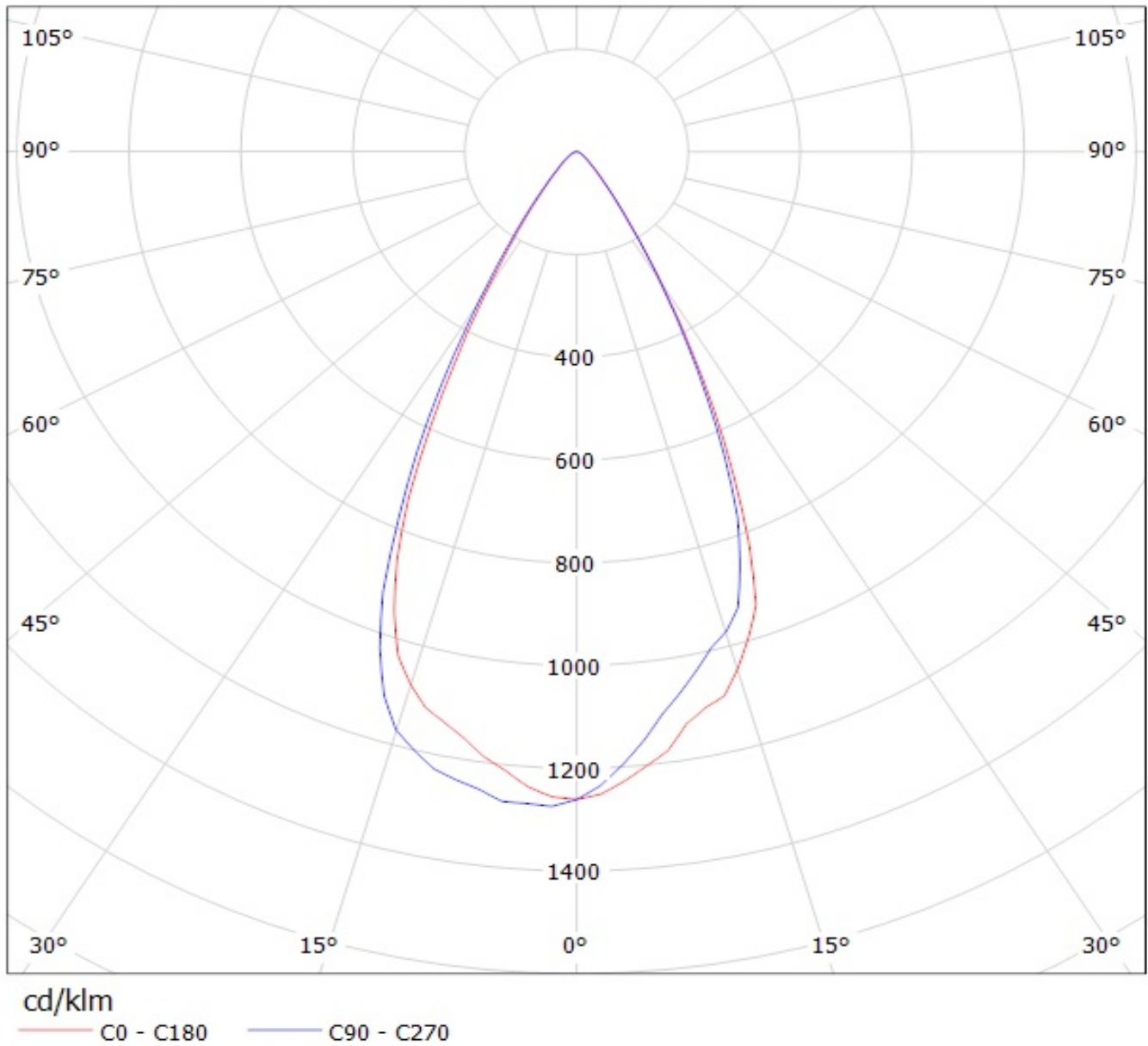



Luminaire: Ledil Oy C13605\_HB-2X2-RW\_(NVSxx19B) Efficiency=90%  
Lamps: 1 x Nichia NVSxx19B (NVSL219BE) 308lm @ 250mA CCT=3100K P=2.9W I=250mA

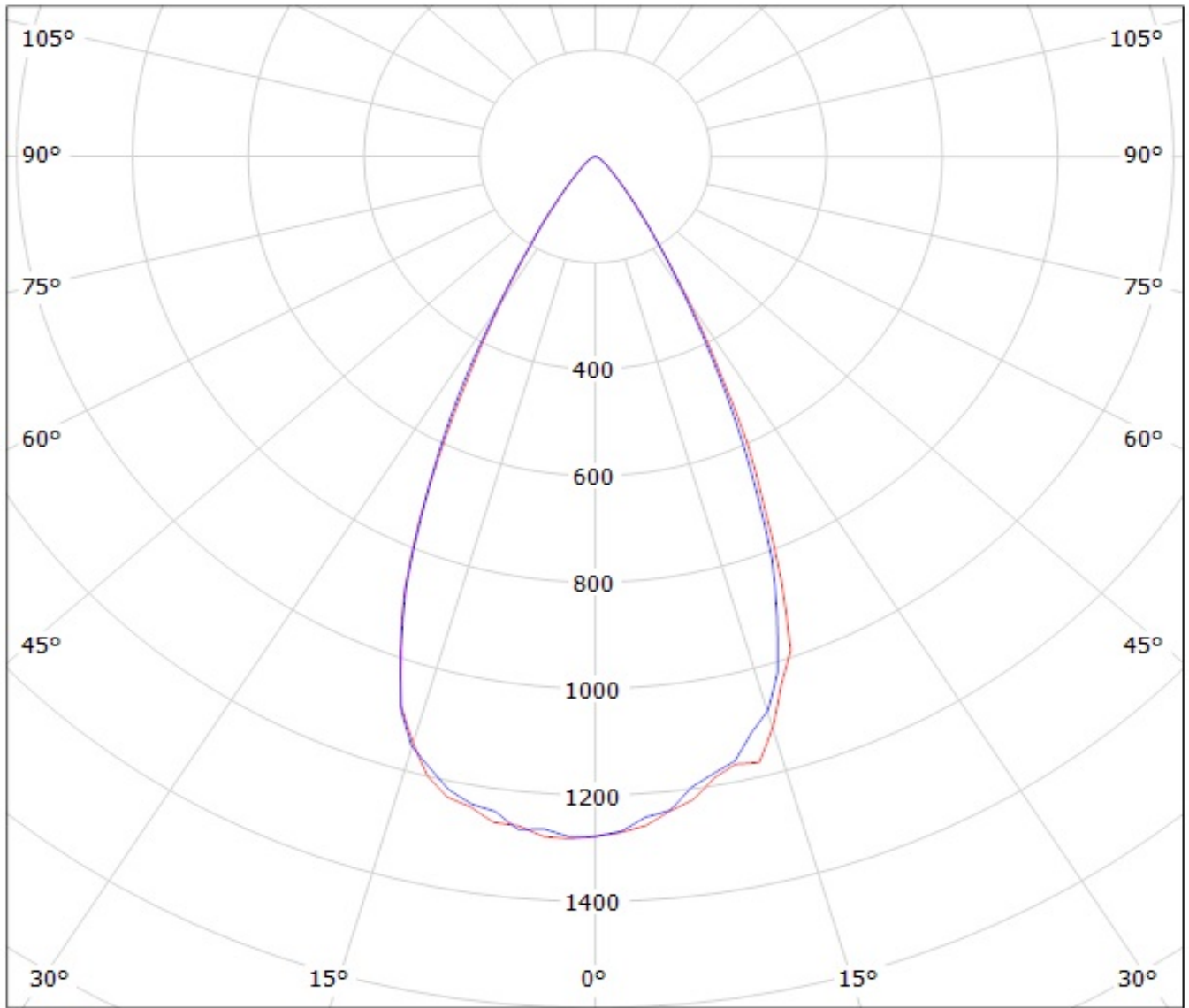

cd/klm

— C0 - C180    — C90 - C270

Luminaire: LEDiL Oy C13605\_HB-2X2-RW\_(E21A)

Lamps: 1 x Nichia\_E21A\_2X2\_454.11lm@250mA\_P=2.81W\_I=0.250A

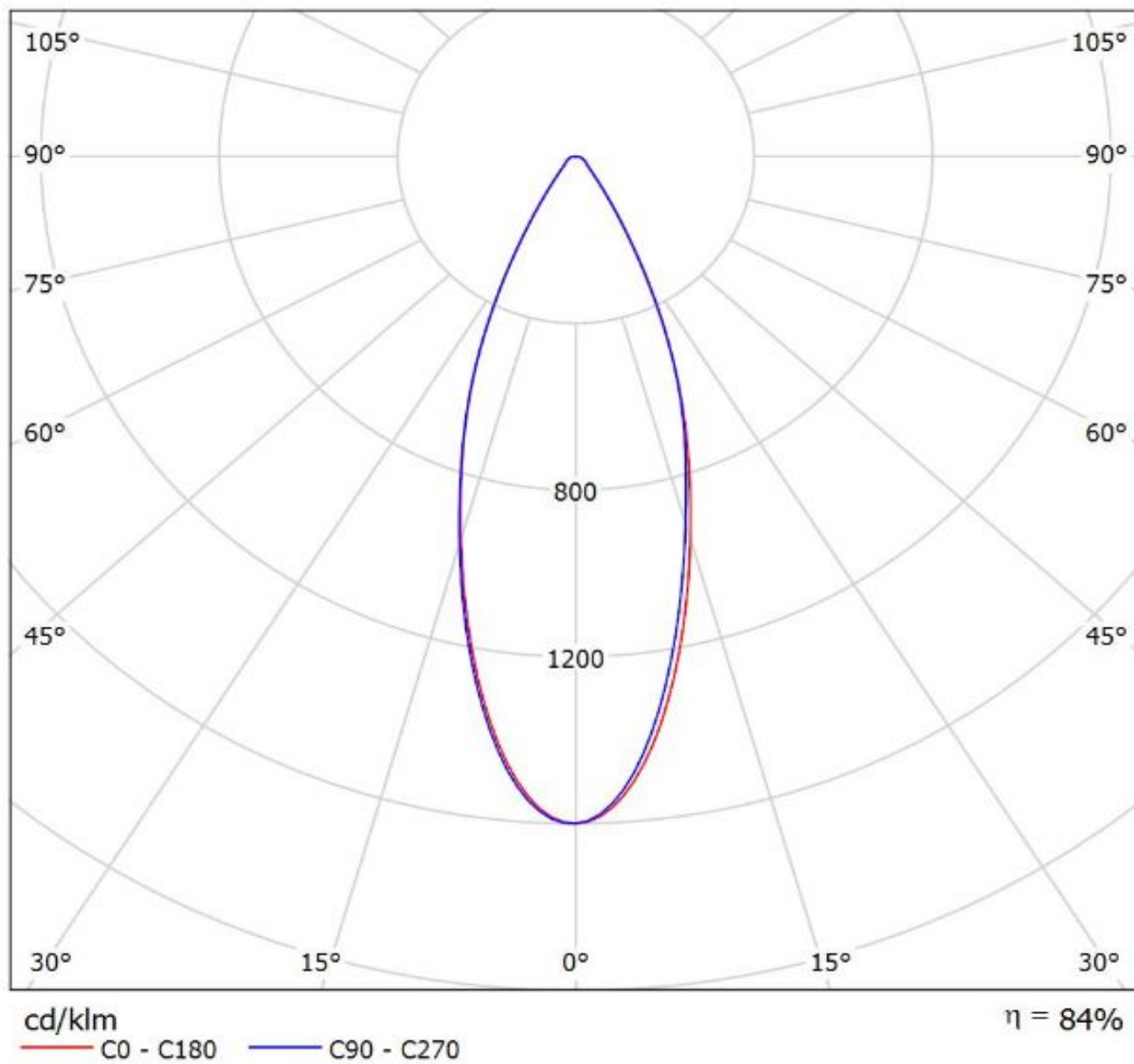

Luminaire: Ledil Oy C13605\_HB-2X2-RW\_(Oslon\_Square\_PC) Efficiency=90%

Lamps: 1 x Osram Oslon Square PC (LCW-CQAR.PC-MSMU-5H71-1) 389lm @ 250mA CCT=6000K P=3.0W I=250mA

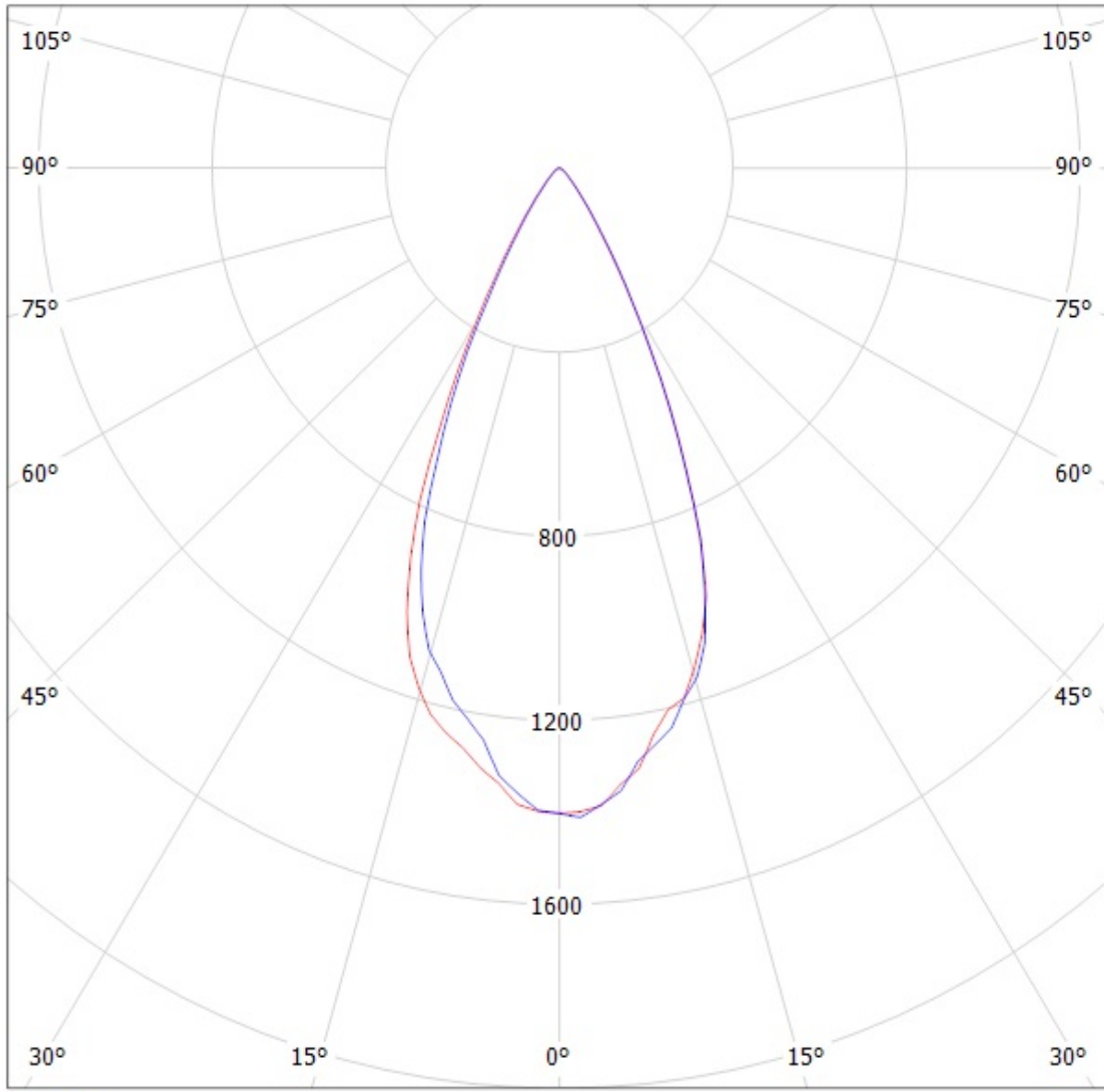

cd/klm

— C0 - C180    — C90 - C270

Luminaire: Ledil Oy C13605\_HB-2X2-RW\_(SSL\_80) Efficiency=90%  
Lamps: 1 x Osram Oslon SSL 80 (310lm @ 250mA) CCT=6800K P=3.2W I=250mA

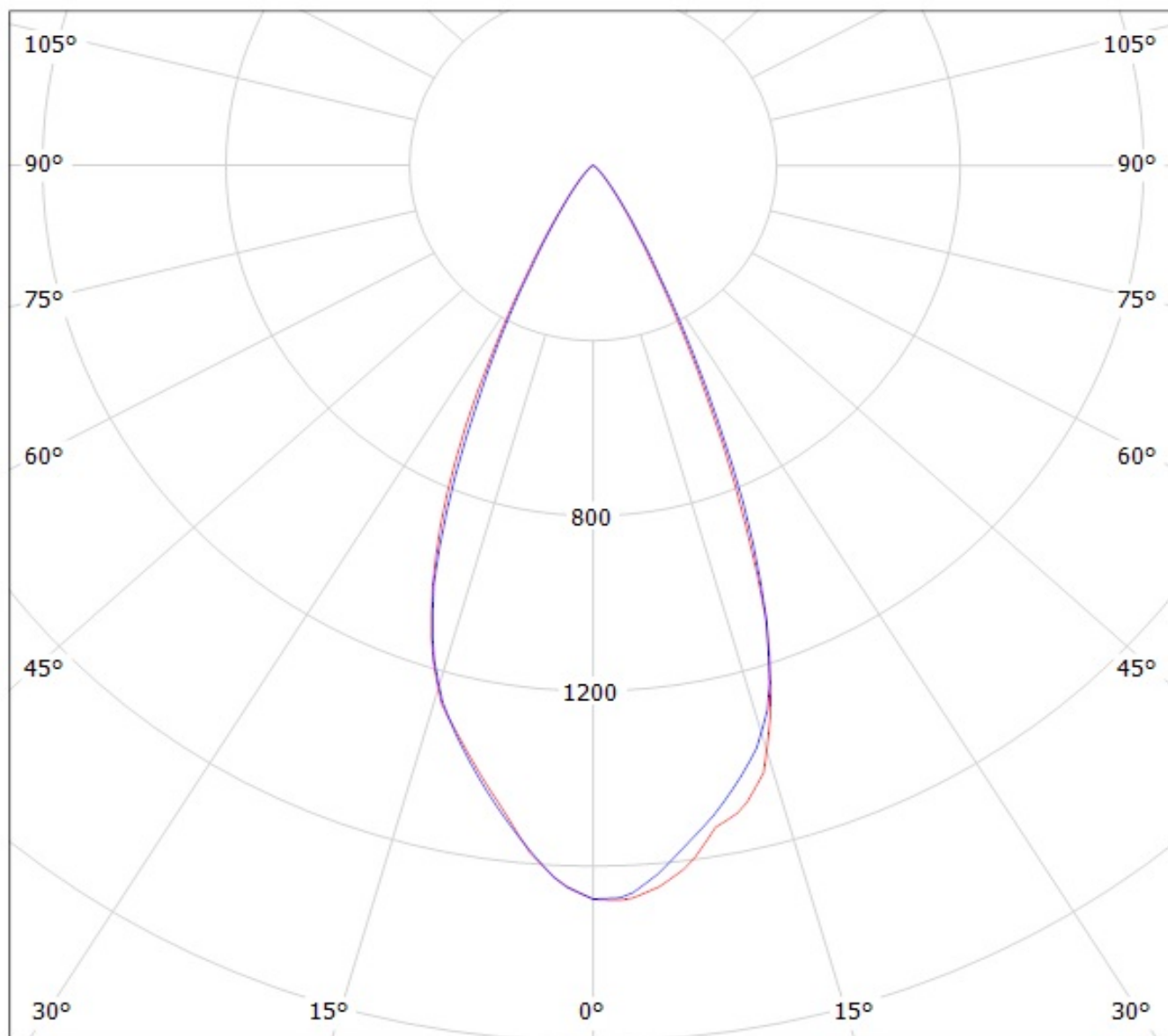

cd/klm

— C0 - C180

— C90 - C270

Luminaire: LEDiL Oy  
Lamps: 1 x C13605-HB-2x2-RW\_(SQ\_Gen3)

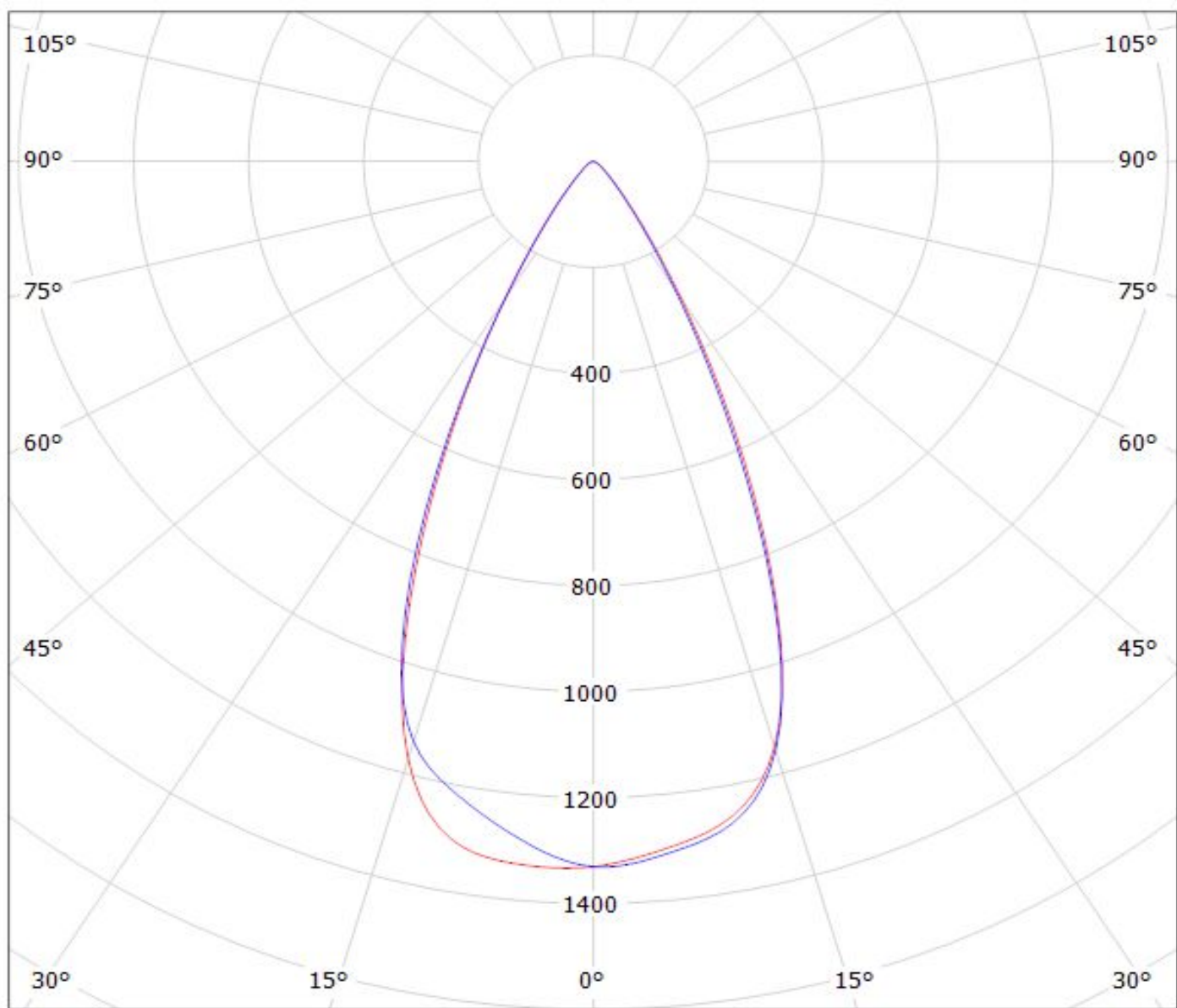

cd/klm

— C0 - C180    — C90 - C270

$\eta = 89\%$

Luminaire: LEDiL Oy C13605\_HB-2X2-RW\_(LH351Z) Eff.90.2%

Lamps: 1 x SAMSUNG\_LH351Z\_2x2\_359.49lm@250mA\_P=2.86371W\_I=249.8mA

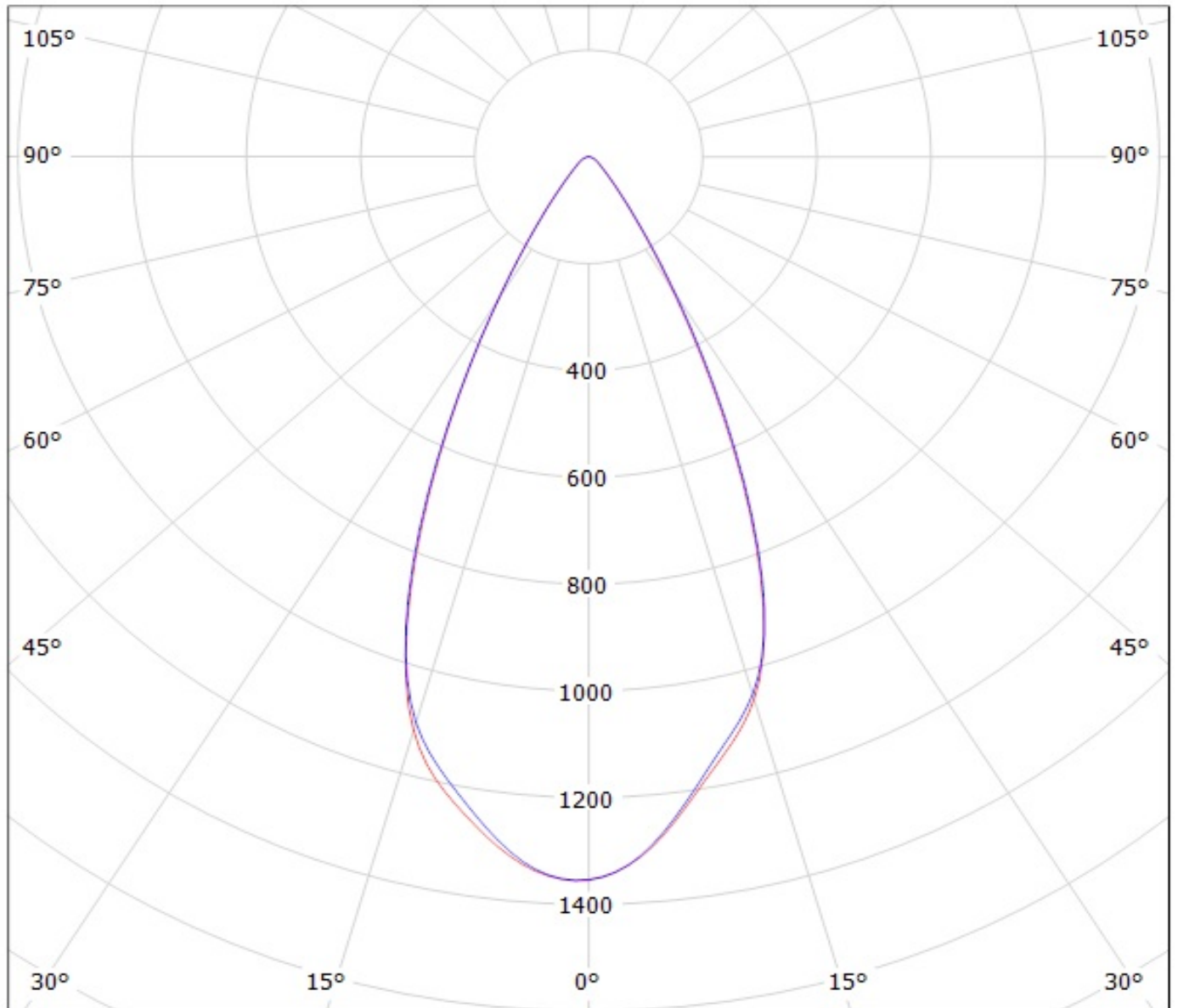

cd/klm

— C0 - C180

— C90 - C270

Luminaire: LEDil Oy C13605\_HB-2x2-RW\_(Z5M1) Efficiency=90%  
Lamps: 1 x Seoul (SZ5-M1-WN-C8) 379lm @ 250mA CCT=4600K P=2.9W I=250mA

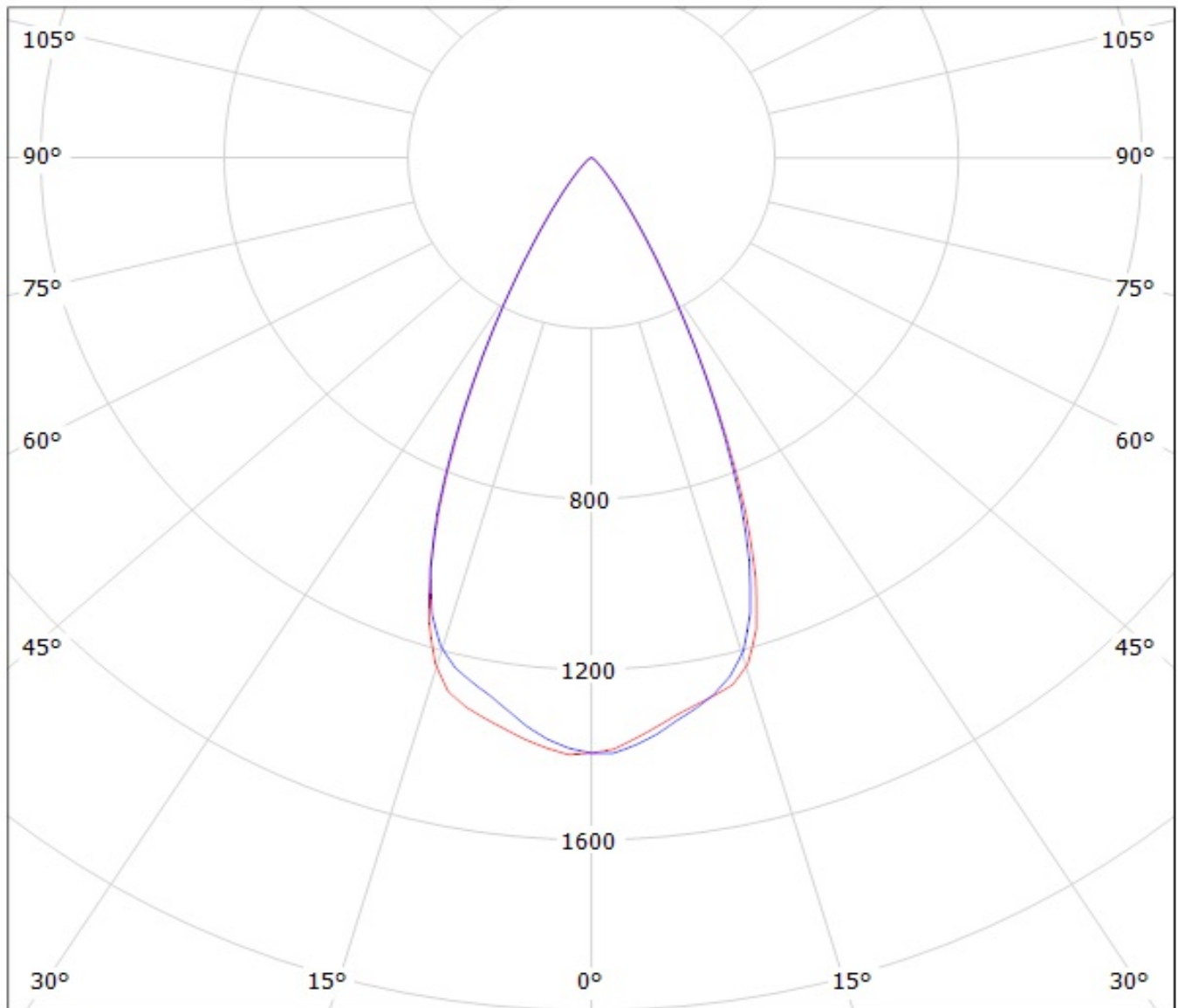

cd/klm

— C0 - C180

— C90 - C270



Luminaire: LEDiL Oy C13605\_HB-2X2-RW\_(WICOP2\_Z8Y15)

Lamps: 1 x SEOUL\_WICOP2\_Z8Y15\_336.842lm@250mA\_P=2.9399W\_I=0.250A

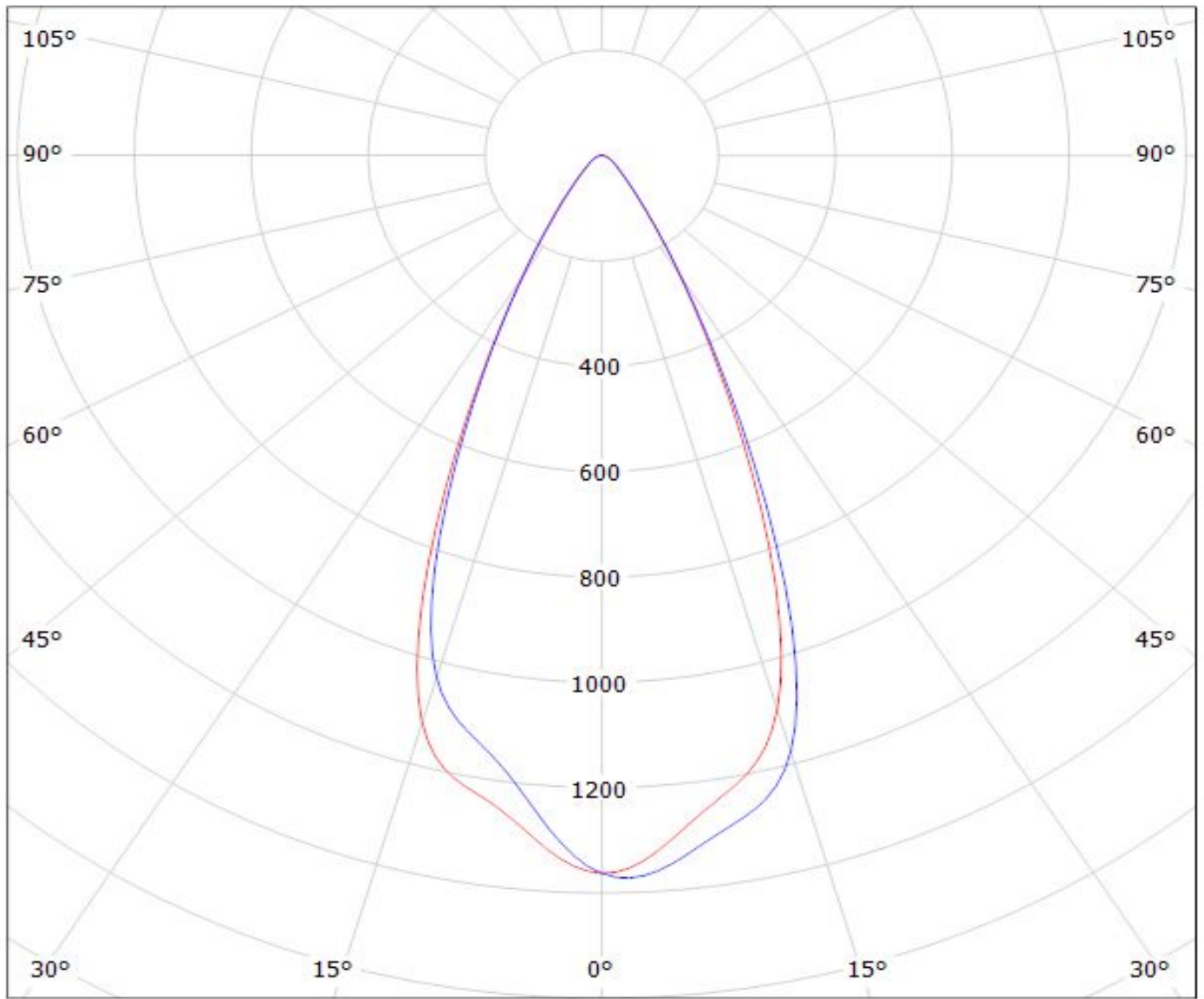

cd/klm

— C0 - C180    — C90 - C270

$\eta = 88\%$



Luminaire: LEDiL Oy C13605\_HB-2X2-RW\_(WICOP2\_Z8Y19)

Lamps: 1 x SEOUL\_WICOP2\_Z8Y19\_450.124lm@250mA\_P=2.8579W\_I=0.250A

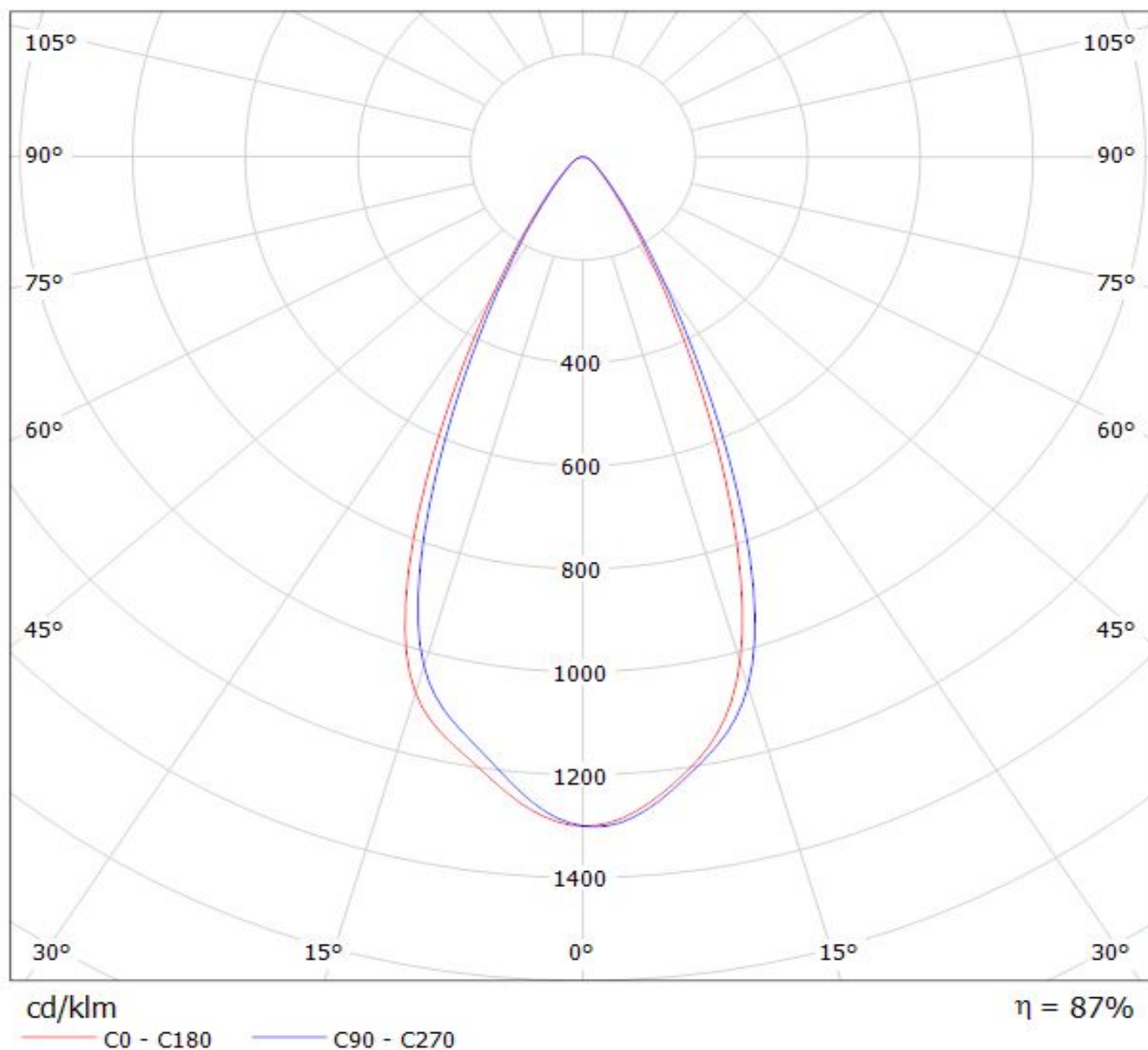

# Ledil C13605\_HB-2X2-RW\_(TL1L4) / LDC (Polar)

Luminaire: Ledil C13605\_HB-2X2-RW\_(TL1L4)

Lamps: 1 x Toshiba\_TL1L4\_2x2\_(TL1L4-DW0)\_472.639lm@250mA\_CCT=6500K\_P=2.9W\_I=0.25A

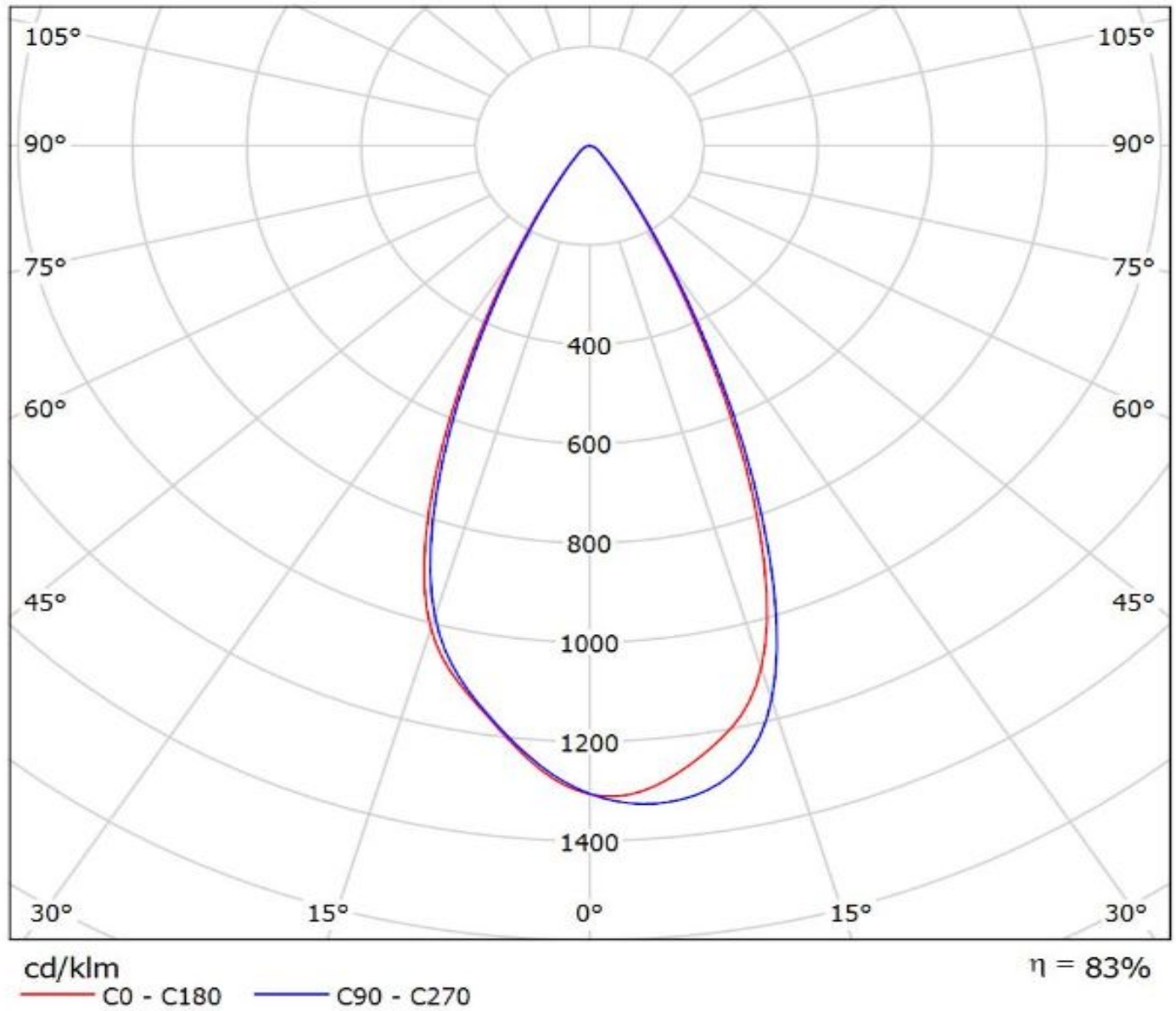

Luminaire: LEDiL Oy C13605\_HB-2X2-RW\_(Tridonic\_Module\_RLE\_G1)  
Lamps: 1 x Tridonic\_Module\_RLE\_G1\_4576.03lm@700mA\_P=32.0681W\_I=0.700A

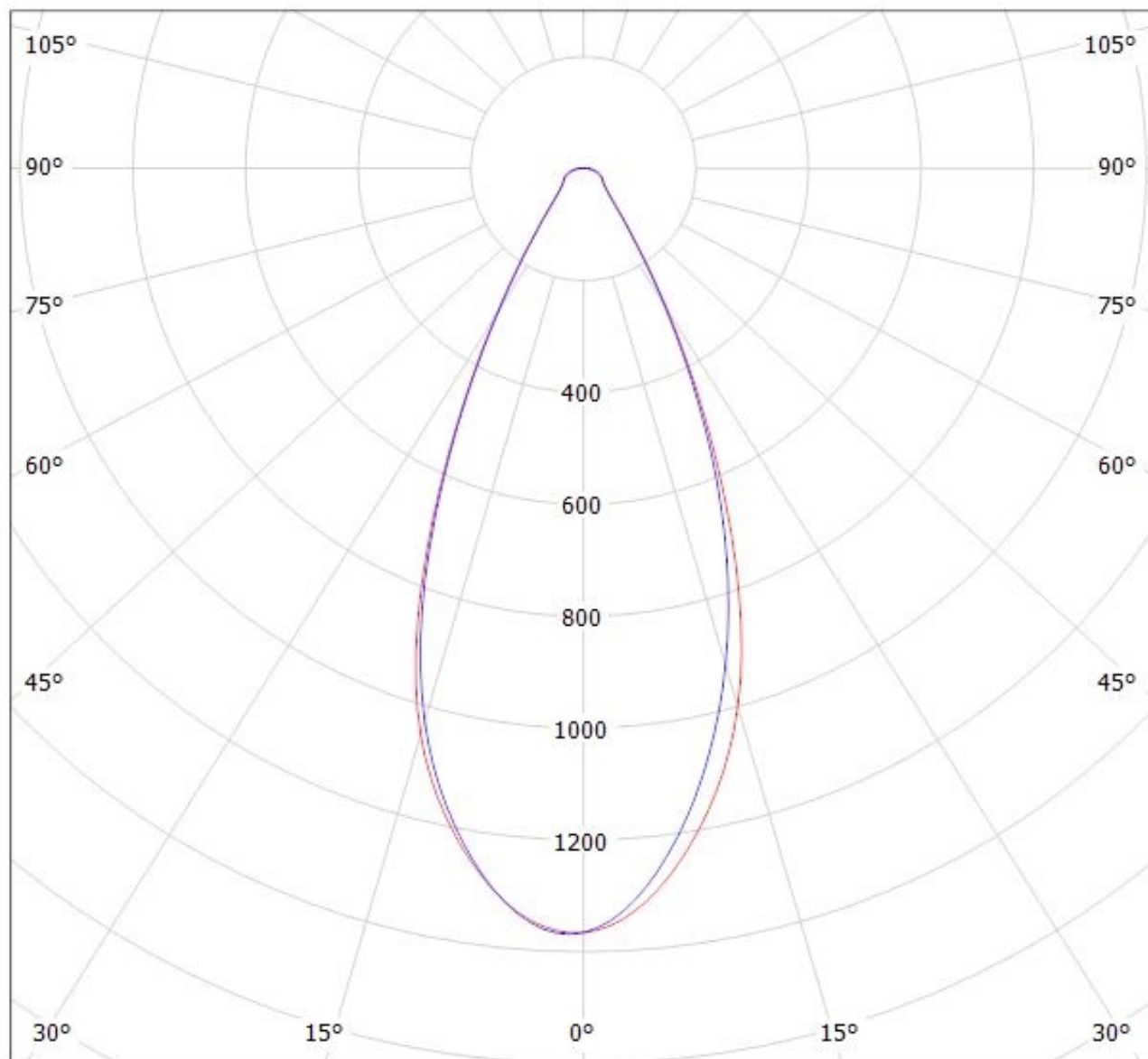

cd/klm

$\eta = .94\%$

— C0 - C180    — C90 - C270

Luminaire: LEDiL Oy C13605\_HB-2X2-RW\_(Tridonic\_Module\_RLE\_G1)  
Lamps: 1 x Tridonic\_Module\_RLE\_G1\_4576.03lm@700mA\_P=32.0681W\_I=0.700A

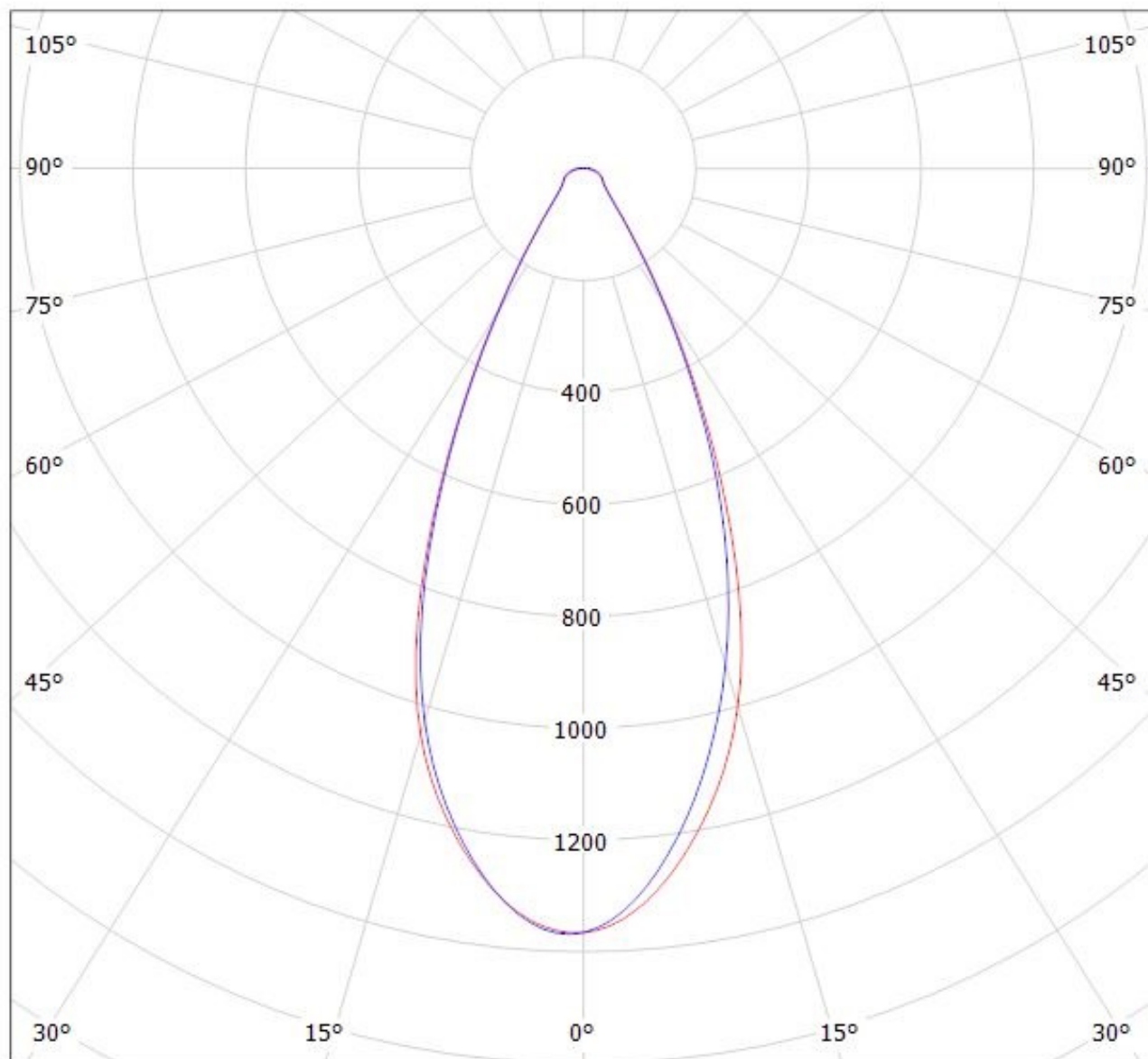

cd/klm

$\eta = .94\%$

— C0 - C180    — C90 - C270

Luminaire: LEDiL Oy C13605\_HB-2X2-RW\_(Tridonic\_Module\_RLE\_G1)  
Lamps: 1 x Tridonic\_Module\_RLE\_G1\_2288lm@700mA\_P=16W\_I=0.700A

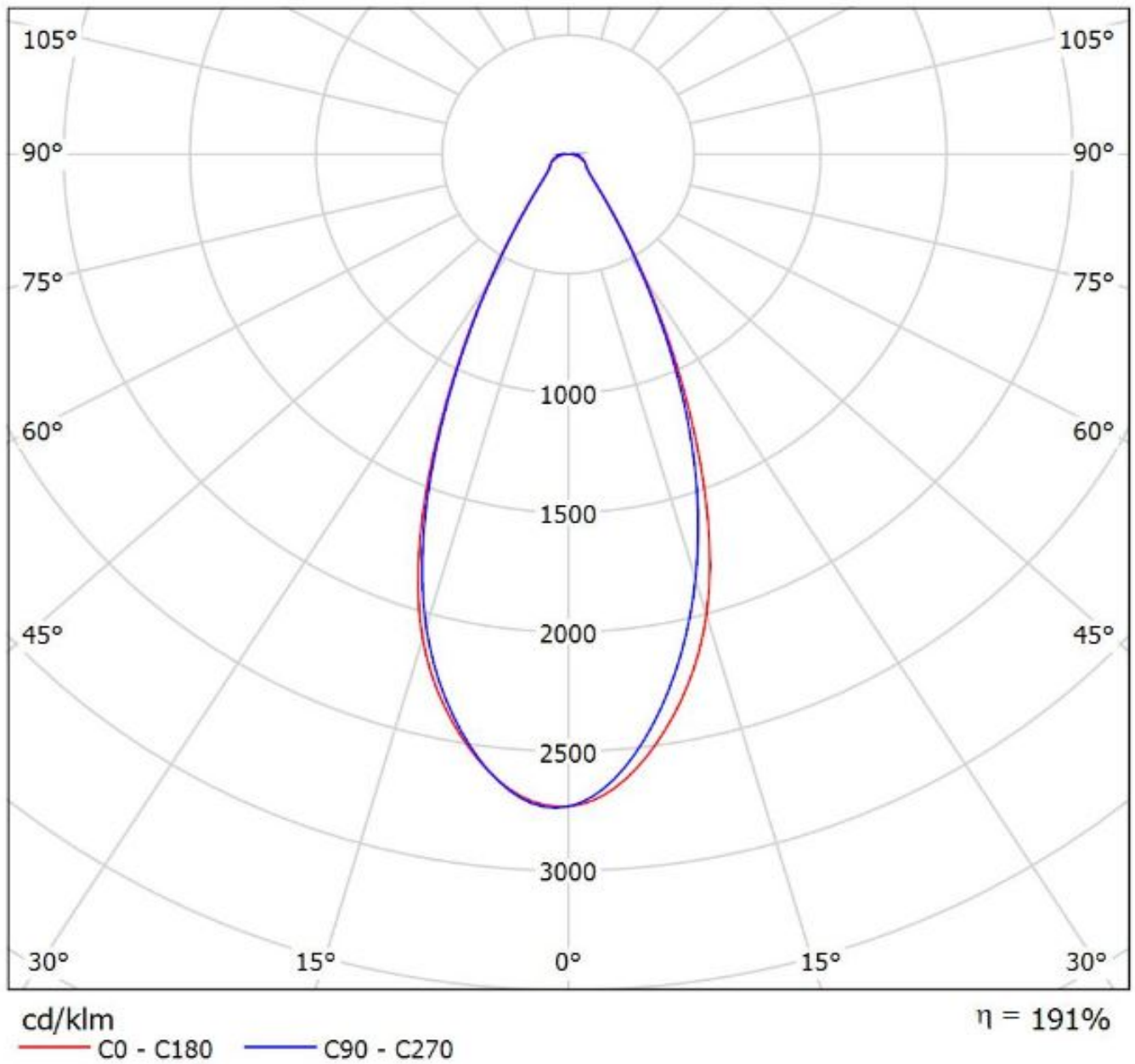



Luminaire: LEDiL Oy C13605\_HB-2X2-RW\_(Tridonic\_Module\_RLE\_G1)  
Lamps: 1 x Tridonic\_Module\_RLE\_G1\_2288lm@700mA\_P=16W\_I=0.700A

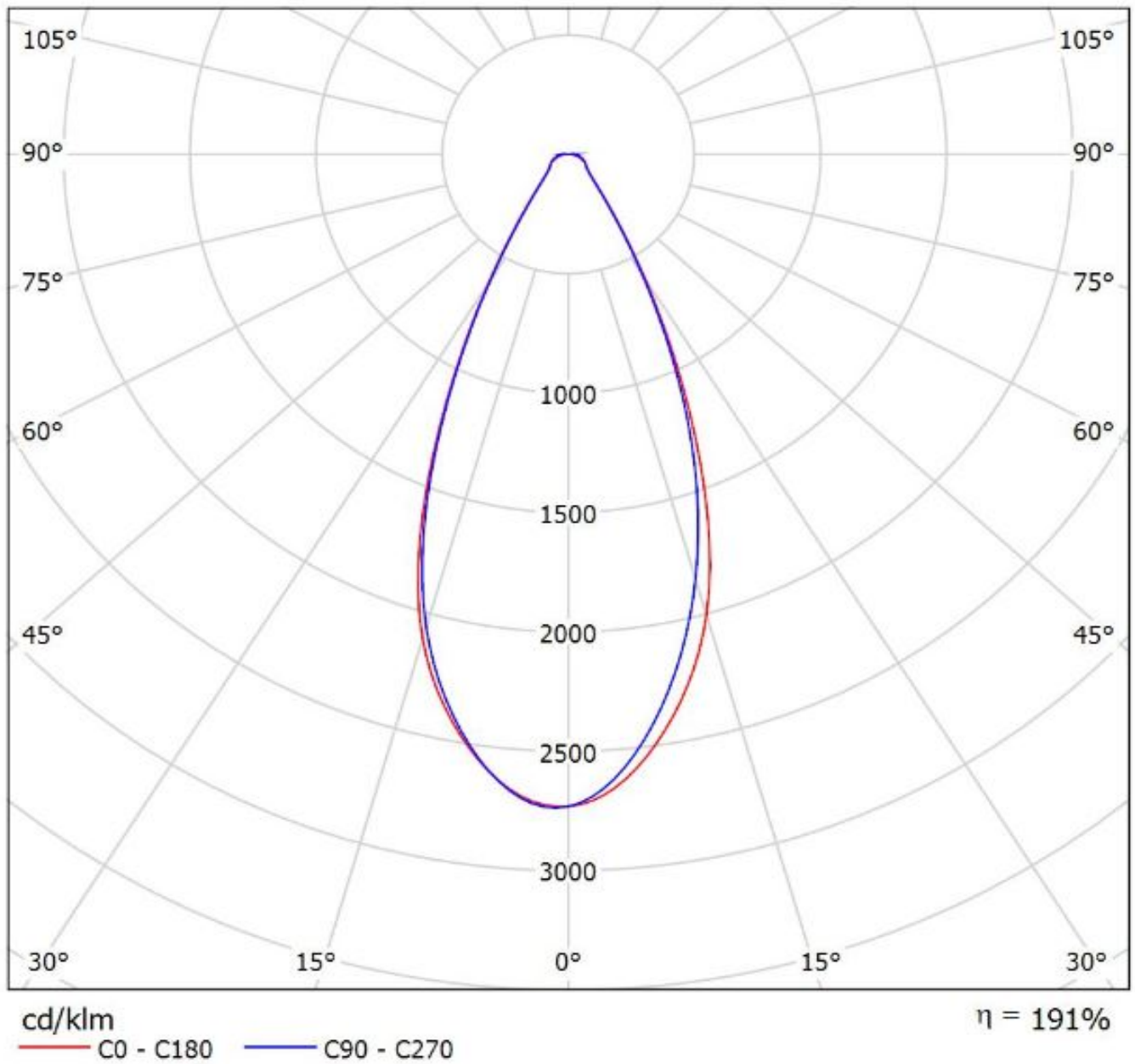

**NOTE: The typical divergence will be changed by different color, chip size and chip position tolerance. The typical total divergence is the full angle measured where the luminous intensity is half of the peak value.**