

REV - DESCRIPT - DATE - APPRVD
A - UPDATED NOTES - 2006/06/16 - YK.
B - CHG SOLDER TAILS - 2006/07/18 - YK.
C - UPDATED MATERIALS - 2006/08/18 - YK.
D-STAKING ADDED: NOT APPROVED BY CUSTOMER-JUNE28,07-A.G.
E - O RING SIZE CHNAGED - SEPT28,07 - A.G.
F - TIGHTENING TORQUE ADDED - OCT23,07 - A.G.
G - REV TOLERANCE, EAR 13547 - JUN11/09 - K.L.

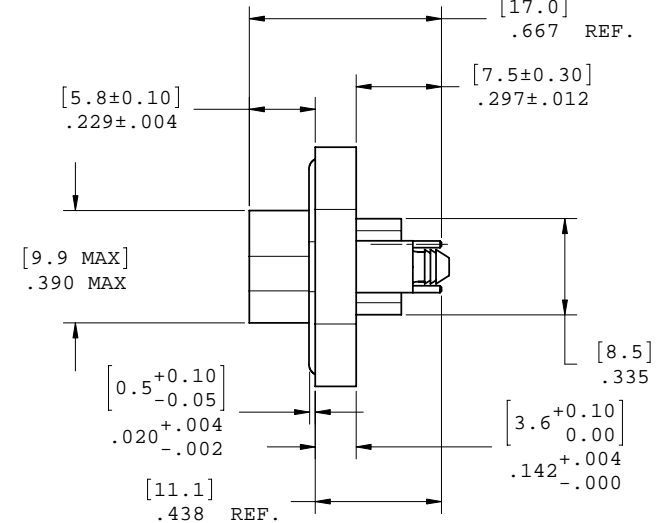
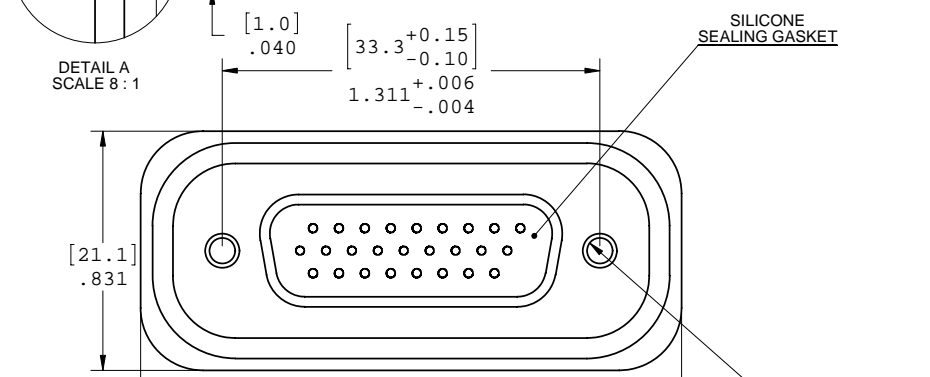
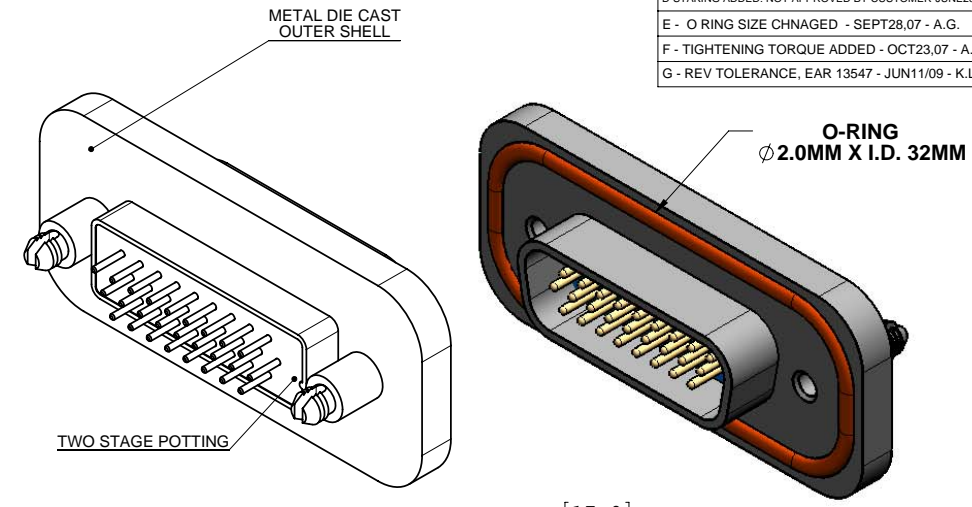
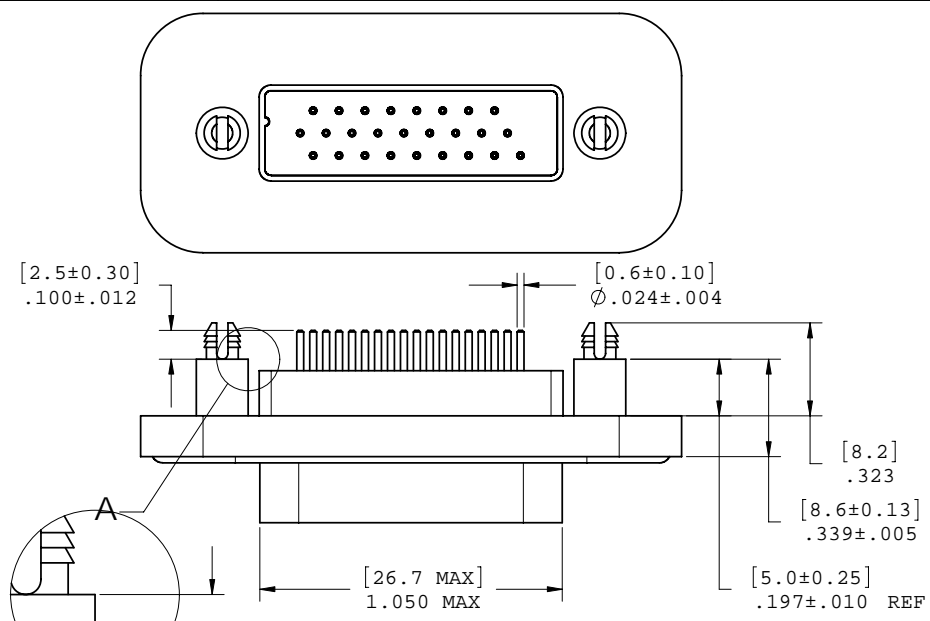

- NOTES:
- MATERIAL:
    - SHELL: ZINC ALLOY 50 MICRO INCH MINIMUM NICKEL PLATING.
    - CONTACTS: COPPER ALLOY 30 MICRO INCH GOLD OVER 50 MICRO INCH NICKEL PLATING.
    - INSULATOR: THERMOPLASTIC POLYESTER RESIN (DSM) 94V-0 FLAMMABILITY RATING.
    - GASKETS: SILICONE RUBBER S7001R, 70 DUROMETER.
    - SEALING COMPOUND: STYCAST 2651 WITH CATALYST 11

- FEATURES: SEALED CONNECTOR IN THE MATED AND UNMATED CONDITIONS.
- OPERATING TEMPERATURE: -40°C TO +105°C.
- ENVIRONMENT PERFORMANCE: IP67.
- PART IS RoHS COMPLIANT.
- REAR SEAL TO WITHSTAND TEMPERATURE EXPOSURE OF SOLDER BATH 265°C FOR 8 SEC & SOLDER PREHEAT 150°C FOR 180 SEC.
- SEALED TO WITHSTAND PRESSURE UP TO 5 PSI AFTER HIGH TEMPERATURE EXPOSURE.
- RECOMMENDED TORQUE FOR SCREW TIGHTENING:
  - STEEL SCREW WITH MORE THAN .090" OF THREAD ENGAGEMENT: 4.0 TO 5.75 IN-LBS.
  - BRASS SCREW: 3.1 TO 4.5 IN-LBS.

AMPHENOL PART NUMBER: MDB-A26PE-860



UNLESS OTHERWISE SPECIFIED DIMENSIONS ARE IN MILLIMETER TOLERANCES ARE:		APPROVALS	DATE	Amphenol Canada Corp.			
DECIMALS	ANGLES	DRAWN	2006/07/24				
.XX ±.10	± 1°	DESIGNED	2006/07/24	TITLE MDB SERIES RUGGED D-SUB CONNECTOR, 26 SIZE HIGH DENSITY PIN, VERTICAL PCB TAIL, RoHS COMPLIANT			
.X ±.25		S.CHEKOV					
MATERIAL AND FINISH		CHECKED				SIZE	DWG. NO.
REF.		QA APP'D				C	P-MDB-A26PE-860
CODE IDENT. NO.		IE APP'D		SCALE	PROJECT		
		DWG APP'D	2006/07/24	1:0.333333	MDB-A26		
					SHEET		
					1 OF 2		

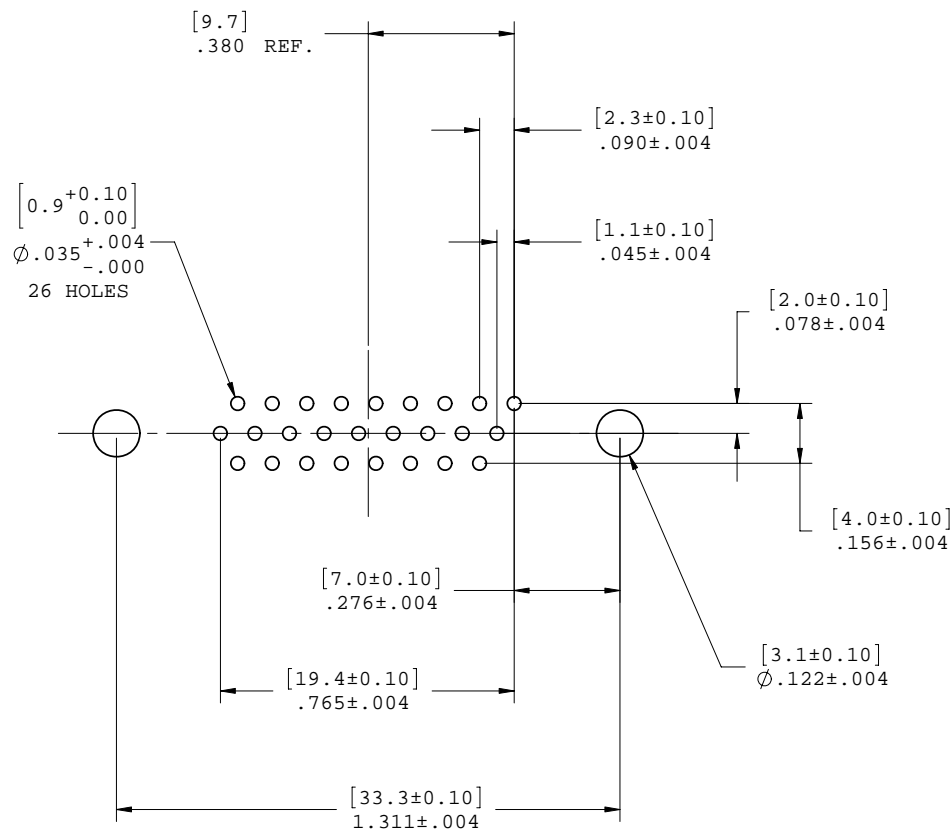

PCB LAYOUT

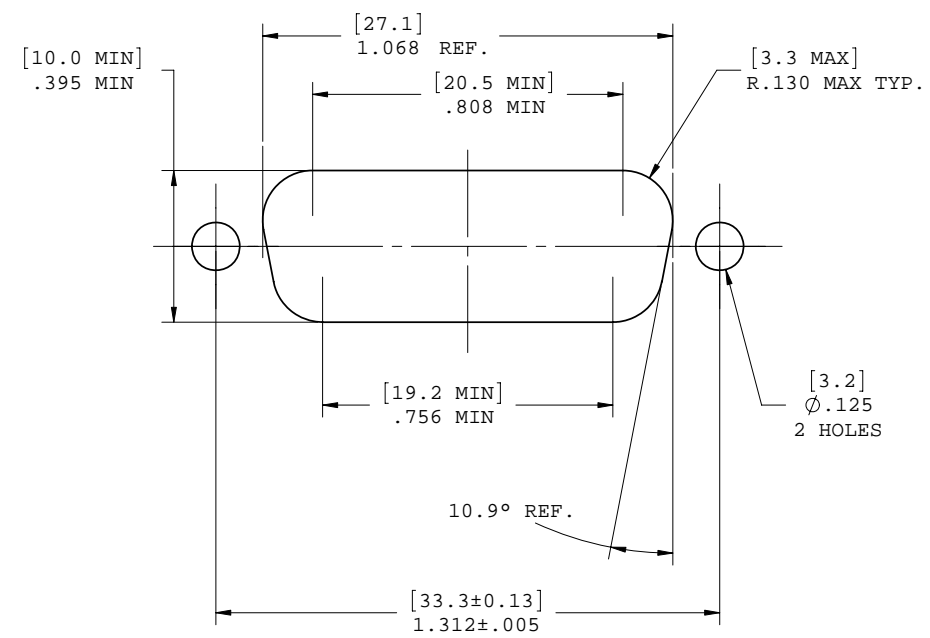

EXISTING PANEL CUTOUT



UNLESS OTHERWISE SPECIFIED DIMENSIONS ARE IN MILLIMETER TOLERANCES ARE:		APPROVALS	DATE	Amphenol Canada Corp.	
		DRAWN Y.KUZYK	2006/07/24		
DECIMALS .XX ±.10 .X ±.25	ANGLES ± 1°	DESIGNED S.SEMENOV	2006/07/24	TITLE MDB SERIES RUGGED D-SUB CONNECTOR, 26 SIZE HIGH DENSITY PIN, VERTICAL PCB TAIL, RoHS COMPLIANT	
MATERIAL AND FINISH		CHECKED			
		QA APP'D			
		IE APP'D			
REF.		DWG APP'D	2006/07/24	SIZE C	DWG. NO. P-MDB-A26PE-860
CODE IDENT. NO.				SCALE 4:1	PROJECT MDB-A26
				REV. G	SHEET 2 OF 2

DO NOT SCALE DRAWING  
 THIS DOCUMENT CONTAINS PROPRIETARY INFORMATION AND SUCH INFORMATION MAY NOT BE DISCLOSED TO OTHERS FOR ANY PURPOSE OR USED FOR MANUFACTURING PURPOSES WITHOUT PERMISSION FROM AMPHENOL CANADA CORP.

