

D/649/6 February 2013

Features

- **Multiple Codec Modes, 16 to 128 kbps**
 - Full duplex ADM and CVSD
 - Full duplex PCM: μ -law, A-law, Linear
 - Configurable ADM time constants
 - Dual channel transcoder/decoder mode
- **High Performance Digital Architecture**
- **Low Power: 2.4mA at 3.0V typ.**
- **2.7V - 5.5V Supply**
- **Data Clock Recovery**
- **Programmable Voice Activity Detector (VAD)**
 - Adjust threshold level and attack/decay time
 - Use to powersave on low signal level
 - Silence/blank low level signals
- **Programmable Digital Scrambler**
- **Flexible Interfaces**
 - 8-bit and 16-bit burst data with sync strobe
 - 1 bit serial data with clock
 - Host serial control/data interface

- **Internal and External Sample Clocking**
- **Programmable Filters**
 - Encoder mic input ADC anti-alias
 - Decoder audio out DAC anti-imaging
- **Low Noise Differential Mic Input Amp**
- **Programmable Analog Interface Gain**
 - Microphone in
 - Decoder audio out
 - Sidetone path

Applications

- **Low Cost Digital Cordless Headset**
- **Personal Area Network (PAN) Voice Link**
- **Digital Cordless Telephone**
- **Wireless Digital PBX**
- **Full Duplex Digital Radio Systems**
- **Time Division Duplex (TDD) Systems**
- **Portable Digital Voice Communicator**
- **Digital Voice Delay**

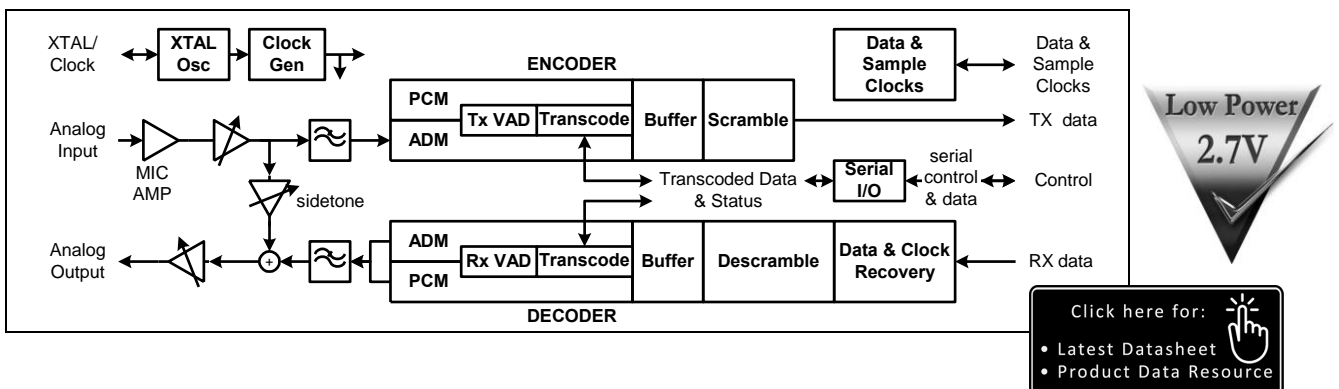

1. Brief Description

The CMX649 Adaptive Delta Modulation (ADM) Voice Codec provides full duplex ADM, companded (μ /A-law) PCM and linear PCM codec and transcoder functions for cost effective, low power, wireless voice applications. Selectable modes and algorithms support many requirements. Robust ADM coding (e.g. CVSD) reduces host protocol and software burdens, eliminating forward error correction, framing protocols and algorithm processing. Dual transcode/decode mode supports multichannel applications.

Integrated filter responses adjust independently of 16kbps to 128kbps codec data rates. Codec sample clocks are externally applied or internally generated. High performance analog interfaces and sidetone include digital gain controls. Encoder and decoder voice activity detectors support powersaving.

The CMX649 ADM Voice Codec supports 2.7V to 5.5V operation and is available in 20-pin SOIC (D3) and TSSOP packages (E3) packages.

CONTENTS

| <u>Section</u> | | <u>Page</u> |
|----------------|------------------------------------------------|-------------|
| 1. | Brief Description | 1 |
| 2. | Block Diagram | 4 |
| 3. | Signal List | 5 |
| 4. | External Components | 6 |
| 5. | General Description | 7 |
| 5.1 | Block Descriptions..... | 7 |
| 5.1.1 | ADM Coding Engine..... | 7 |
| 5.1.2 | PCM Encoding and Decoding..... | 8 |
| 5.1.3 | Transcoding with the Encoder and Decoder | 9 |
| 5.1.4 | Non-Linear Instantaneous Comanding..... | 10 |
| 5.1.5 | Digitally Controlled Amplifiers..... | 10 |
| 5.1.6 | Microphone Amplifier | 10 |
| 5.1.7 | Programmable Anti-alias/image SC Filters..... | 11 |
| 5.1.8 | Data Clock Recovery | 12 |
| 5.1.9 | Data Scrambler/De-scrambler..... | 12 |
| 5.1.10 | Voice Activity Detector (VAD) | 13 |
| 5.2 | C-BUS Description | 14 |
| 5.2.1 | Write Only Register Description | 17 |
| 5.2.1.1 | GENERAL RESET..... | 17 |
| 5.2.1.2 | AAF/AIF BANDWIDTH | 17 |
| 5.2.1.3 | VOLUME/SIDETONE LEVEL..... | 18 |
| 5.2.1.4 | AUDIO INPUT LEVEL CONTROL | 19 |
| 5.2.1.5 | POWER CONTROL 1..... | 19 |
| 5.2.1.6 | POWER CONTROL 2..... | 20 |
| 5.2.1.7 | CODEC MODE CONTROL | 21 |
| 5.2.1.8 | SCRAMBLER CONTROL | 21 |
| 5.2.1.9 | CLK DIVIDER CONTROL | 22 |
| 5.2.1.10 | CLK SOURCE CONTROL | 24 |
| 5.2.1.11 | CODEC INTERRUPT CONTROL | 25 |
| 5.2.1.12 | DECODE MODE AND SETUP..... | 26 |
| 5.2.1.13 | DECODE ADM CONTROL..... | 27 |
| 5.2.1.14 | DECODE VAD THRESHOLD..... | 29 |
| 5.2.1.15 | DECODE OFFSET LEVEL | 29 |
| 5.2.1.16 | DECODE LINEAR PCM INPUT..... | 29 |
| 5.2.1.17 | DECODE ADM INPUT | 29 |
| 5.2.1.18 | ENCODE MODE AND SETUP..... | 30 |
| 5.2.1.19 | ENCODE ADM CONTROL..... | 32 |
| 5.2.1.20 | ENCODE VAD THRESHOLD..... | 33 |
| 5.2.1.21 | ENCODE OFFSET LEVEL | 33 |
| 5.2.1.22 | ENCODE DAC INPUT | 34 |
| 5.2.1.23 | ENCODE ADM INPUT TEST | 34 |
| 5.2.2 | Read Only Register Description | 35 |
| 5.2.2.1 | PROCESSOR STATUS READ..... | 35 |
| 5.2.2.2 | DECODE VAD LEVEL OUTPUT READ..... | 35 |
| 5.2.2.3 | DECODE OFFSET LEVEL OUTPUT READ | 35 |
| 5.2.2.4 | DECODE LINEAR PCM OUTPUT READ | 35 |
| 5.2.2.5 | DECODE ADM OUTPUT READ..... | 36 |

| | | |
|---------|------------------------------------------------|----|
| 5.2.2.6 | ENCODE VAD LEVEL OUTPUT READ..... | 36 |
| 5.2.2.7 | ENCODE OFFSET LEVEL OUTPUT READ ... | 36 |
| 5.2.2.8 | ENCODE LINEAR PCM OUTPUT READ | 36 |
| 5.2.2.9 | ENCODE ADM OUTPUT READ..... | 36 |
| 6. | Application Notes..... | 37 |
| 6.1 | C-BUS Operation..... | 37 |
| 6.2 | CODEC Data Interface | 38 |
| 6.3 | Example CODEC Setups and Application Help..... | 40 |
| 7. | Performance Specification | 45 |
| 7.1 | Electrical Performance | 45 |
| 7.2 | Packaging | 50 |

2. Block Diagram

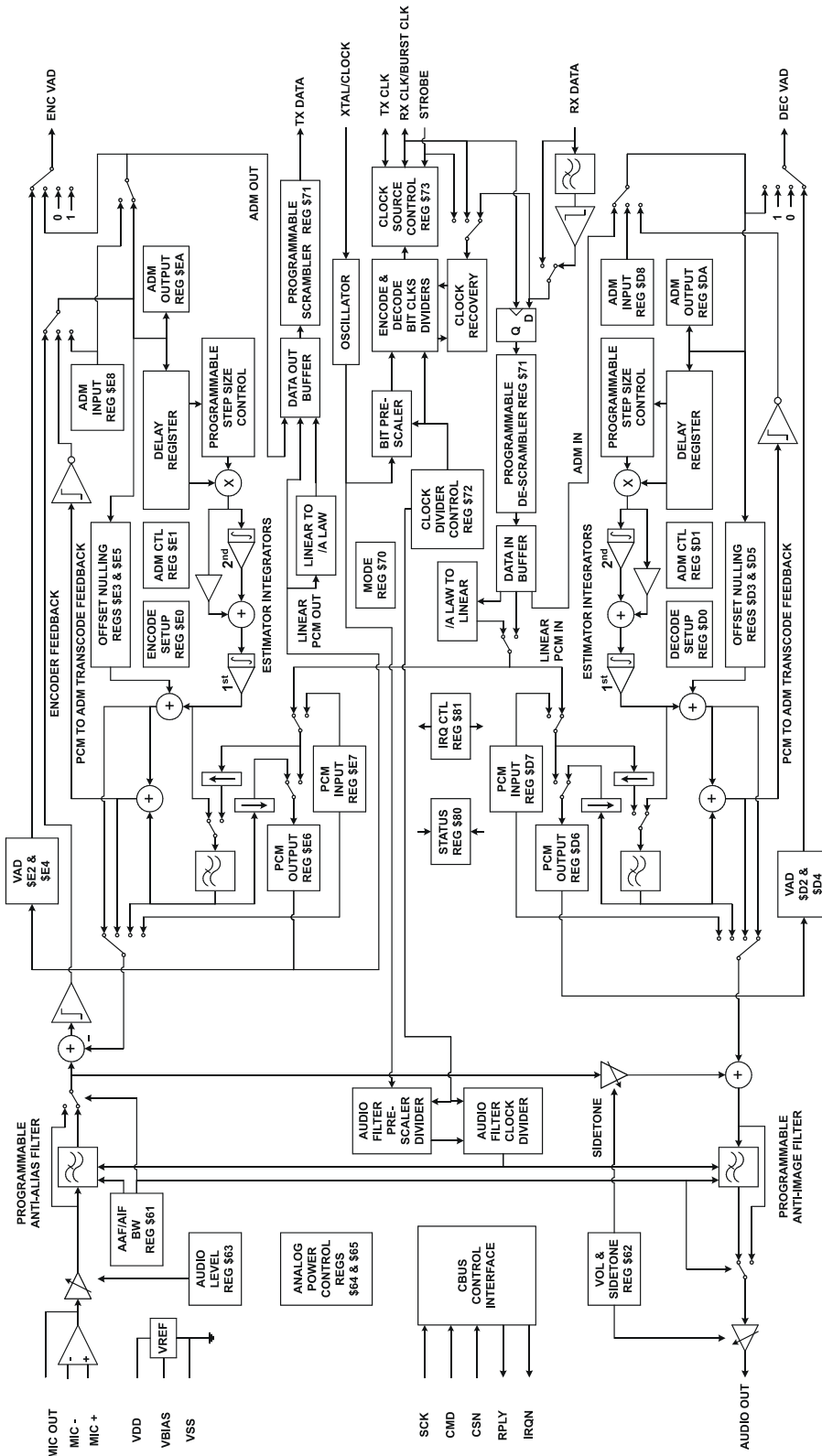

Figure 1 Block Diagram

3. Signal List

| SOIC (D3) Package | TSSOP (E3) Package | Signal | | Description |
|----------------------|-----------------------|-------------------|----------------|----------------------------------------------------------------------------------------------------------------------------------------------------|
| Pin No. | Pin No. | Name | Type | |
| 1 | 1 | STRB | Digital Input | Strobe signal for 8/16 buffered serial I/O. |
| 2 | 2 | ENC VAD | Digital Output | Encoder voice activity detector output. |
| 3 | 3 | V _{DD} | Power | Positive supply rail. |
| 4 | 4 | MIC OUT | Analog Output | Analog output signal from microphone amplifier. |
| 5 | 5 | MIC + | Analog Input | Analog non-inverting input to microphone amplifier. |
| 6 | 6 | MIC - | Analog Input | Analog inverting input to microphone amplifier. |
| 7 | 7 | V _{BIAS} | Analog Output | V _{DD} /2 – Not suitable for external applications without buffering. Pin should be decoupled to V _{SS} with a capacitor (>1µF). |
| 8 | 8 | AUDIO OUT | Analog Output | Analog Output signal from decoder. |
| 9 | 9 | V _{SS} | Power | Negative supply rail (Ground). |
| 10 | 10 | DEC VAD | Digital Output | Decoder voice activity detector output. |
| 11 | 11 | RX DATA | Digital Input | Received signal serial data input. |
| 12 | 12 | RX CLK | Digital I/O | Decoder data clock. |
| 13 | 13 | XTAL/CLK | Analog Input | Crystal oscillator input. |
| 14 | 14 | IRQN | Digital Output |) |
| 15 | 15 | RPLY | Digital Output |) |
| 16 | 16 | CMD | Digital Input |) C-BUS control signals. |
| 17 | 17 | SCLK | Digital Input |) |
| 18 | 18 | CSN | Digital Input |) |
| 19 | 19 | TX CLK | Digital I/O | Clock signal for encoded data out. |
| 20 | 20 | TX DATA | Digital Output | Encoded data output. |

Notes: I/O = Input/Output
 NC = No Connection

4. External Components

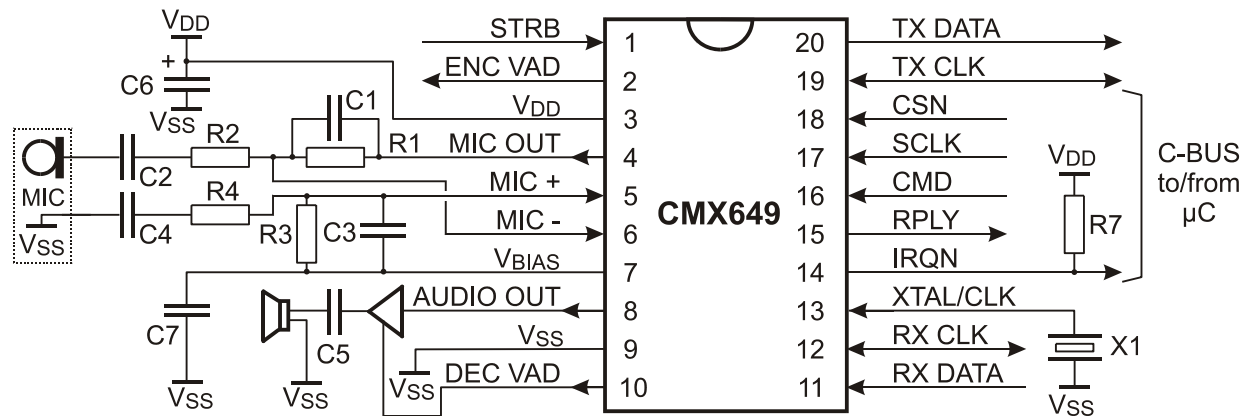

Figure 2 Recommended External Components

| | | | | | | | |
|--------|--------|--------------------|------------|----|--------|--------------------|------------|
| R1, R2 | Note 1 | 100k Ω | $\pm 10\%$ | C5 | Note 2 | 33.0 μF | $\pm 20\%$ |
| R3, R4 | Note 1 | 100k Ω | $\pm 10\%$ | C6 | Note 3 | 1.0 μF | $\pm 20\%$ |
| R7 | | 100k Ω | $\pm 20\%$ | C7 | Note 4 | 1.0 μF | $\pm 20\%$ |
| C1, C3 | Note 1 | 100 pF | $\pm 20\%$ | | | | |
| C2, C4 | Note 1 | 0.01 μF | $\pm 20\%$ | X1 | Note 5 | 8.192MHz | |

Notes:

1. C1 - C4 and R1 - R4 set the microphone amplifier gain and frequency response. The values shown set the gain to unity and the low and high -3dB frequency rolloff points to approximately 150Hz and 15kHz respectively.
2. DC blocking capacitor for driving a speaker from an external speaker amplifier. The value shown is based on a 32 Ω impedance speaker where the highpass rolloff frequency is set to approximately 150Hz.
3. V_{DD} decoupling capacitor.
4. Bias decoupling capacitor.
5. A 8.192MHz Xtal/Clock input will yield exactly 16kbps/32kbps/64kbps internally generated data clock rates.
6. To achieve good noise performance, V_{DD} and V_{BIAS} decoupling and protection of the signal path from extraneous in-band signals are very important. It is recommended that the printed circuit board is laid out with a ground plane in the CMX649 area to provide a low impedance connection between the V_{SS} pin and the V_{DD} and V_{BIAS} decoupling capacitors.

5. General Description

The CMX649 encodes and decodes analog audio signals to/from ADM, Linear PCM, μ -law PCM or A-law PCM. It has programmable clock dividers that enable it to use an 8.000 MHz to 16.384 MHz crystal (or a 2.048 MHz to 16.384 MHz external clock source) and to sample the data over a large range of data rates. Programmable current sources for on-chip op-amps enable the overall power consumption to be optimised for any given supply voltage and clocking scheme, thus achieving extremely low working power levels.

Anti-Alias Image filters and gain controls are fully programmable. All the time constants and other parameters of the ADM can be programmed for optimum performance.

The CMX649 also includes a Microphone Amplifier, Data Clock Recovery, Data Scrambler/De-Scrambler and Voice Activity Detector (VAD) circuits.

All of these parameters are controlled via C-BUS.

5.1 Block Descriptions

The CMX649 contains a full duplex speech codec supporting common Adaptive Delta Modulation (ADM) and non-linear PCM coding algorithms. In addition, it supports linear PCM coding for DSP interface applications. This codec offers simple interface and application, yet is configurable to support a wide variety of speech quantisation systems.

5.1.1 ADM Coding Engine

ADM is a differential waveform coding technique predominantly applied to speech. Figure 3 illustrates the ADM encoder employed. The device is for speech quantising applications and is based on popular Continuously Variable Slope Delta (CVSD) encoder approaches, with optional modifications and improvements configurable through the ENCODE and DECODE ADM CONTROL Registers (\$E1 and \$D1). Optional second order integration in the feedback loop provides improved speech quality at a given bit rate or similar quality at a lower bit rate. Toll quality is achieved at bit rates much lower than for PCM. The decoder is embedded in the encoder, as is the case with most differential encoders. Note the symmetry between the encoder and decoder of Figures 3 and 4 respectively. The signal flows for ADM are shown in bold.

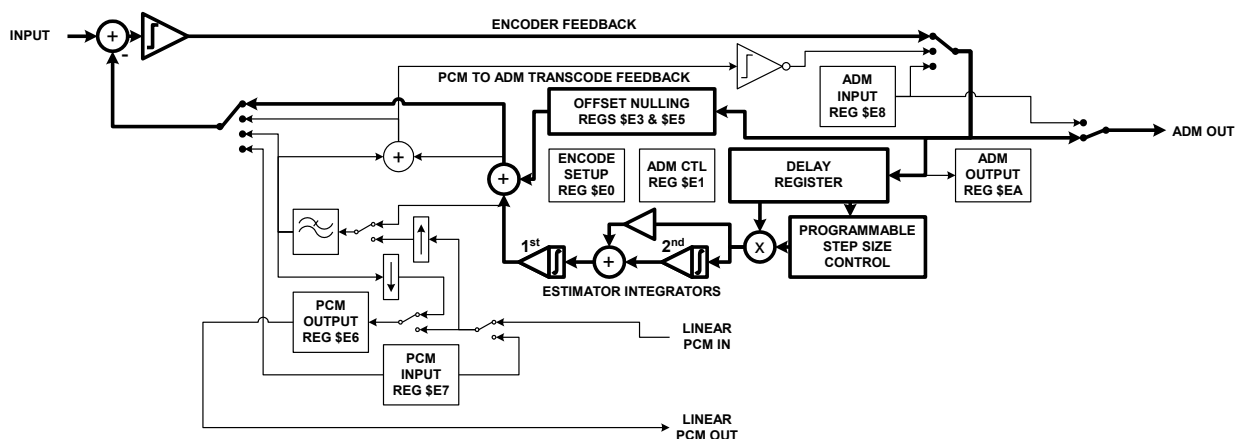

Figure 3 ADM Encoding

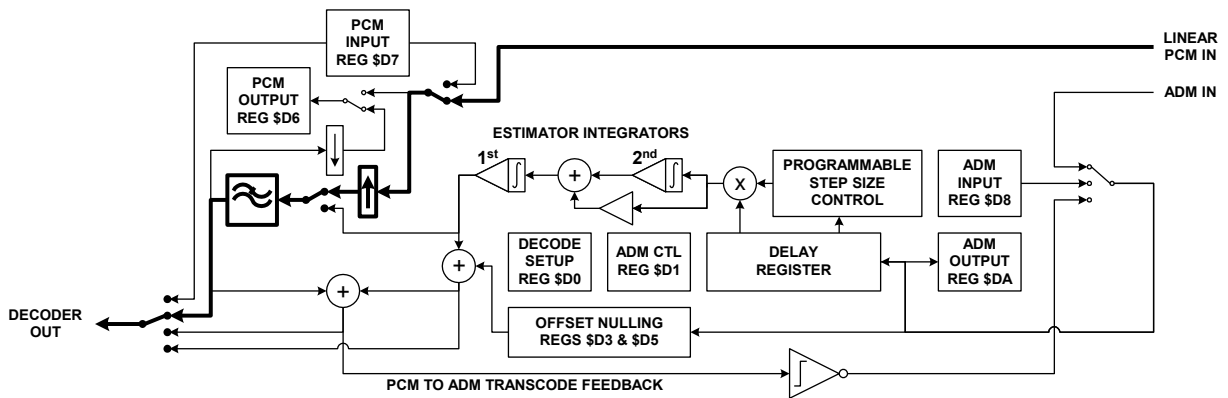

Figure 6 PCM Decoding

5.1.3 Transcoding with the Encoder and Decoder

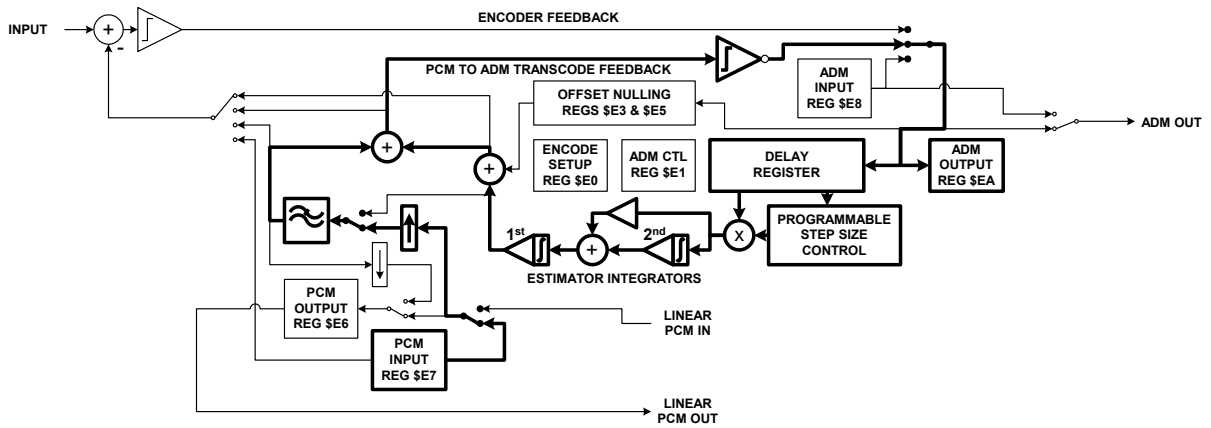

Figure 7 PCM to ADM transcoding with Encoder

(note that the decoder also can be configured to do this function and in this example all data is read and written via C-BUS registers \$EA (\$DA) and \$E7 (\$D7) respectively (for decoder)).

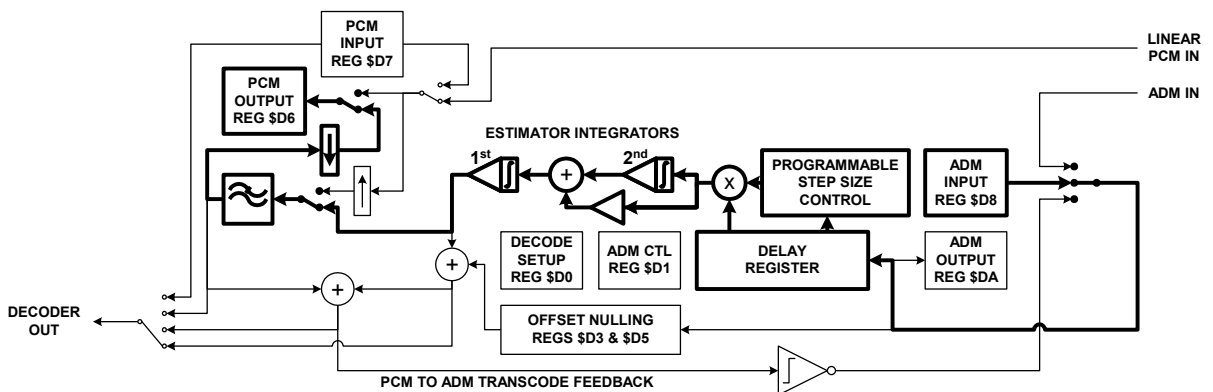

Figure 8 ADM to PCM transcoding with Decoder

(note that the encoder can also be configured to do this function and in this example all data is read and written via C-BUS registers \$D6 (\$E6) and \$D8 (\$E8) respectively (for encoder)).

5.1.4 Non-Linear Instantaneous Companding

When using the device over its standard PCM codec style interface, instantaneous companding can be enabled to cut in half the PCM word size. Either μ -law or A-law type companding algorithms are provided and use 16-chord piecewise linear approximations. Essentially the companded 8-bit PCM word is a simple floating-point representation with a sign bit, a 3-bit exponent and a 4-bit mantissa. This approach yields toll quality speech at reduced data rates.

5.1.5 Digitally Controlled Amplifiers

There are three Digitally Controlled Amplifiers (DCA) on-chip, which are used to set the signal levels for transmit-audio-in, side-tone-audio, and receive-audio-out (volume control). The transmit-audio DCA is adjustable in 0.5dB steps over a +7.5dB to -7.5dB range. The side-tone DCA is adjustable in 6.0dB steps over a 0dB to -21.0dB range. Side-tone audio is added to the audio output signal via an operational amplifier configured as a summing amplifier. This feeds the receive-audio DCA, which is adjustable in 1.5dB steps over a +12.0dB to -33.0dB range.

5.1.6 Microphone Amplifier

The input amplifier is a high gain low-noise operational amplifier capable of interfacing with a variety of different microphones. Figure 9 is a simplified schematic showing the external components required for typical application with an electret condenser microphone. Typical values for R1, R3, C1 and C3 should be set according to microphone sensitivity requirements, those shown are for unity gain. Note also that the microphone biasing resistors (R5 and R6) are microphone specification dependent.

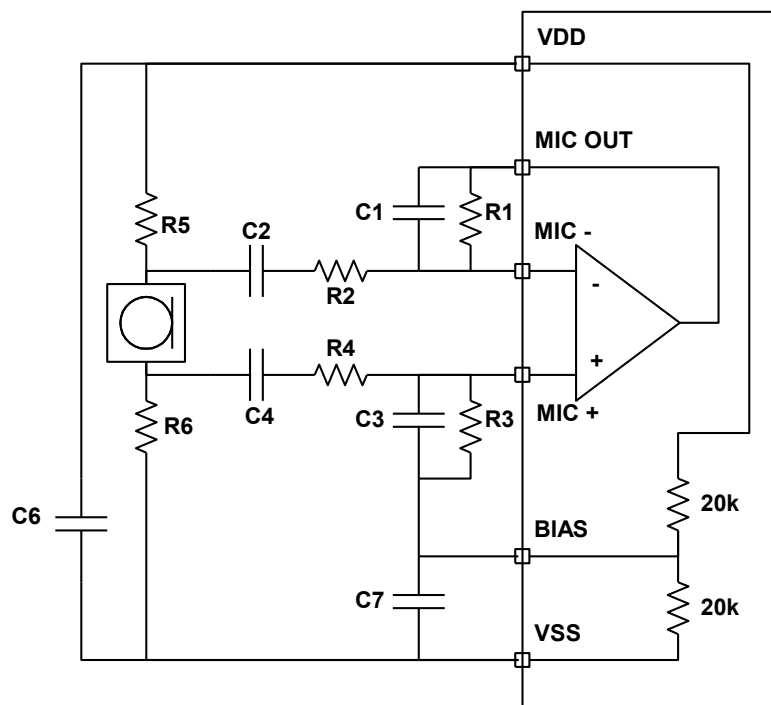

Figure 9 Electret Microphone - Input Amplifier Schematic

| | | | | | |
|--------|---------------|------------|----|---------------|------------|
| R1, R3 | 100k Ω | $\pm 10\%$ | R5 | 100k Ω | $\pm 10\%$ |
| R2, R4 | 100k Ω | $\pm 10\%$ | R6 | 100k Ω | $\pm 10\%$ |
| C1, C3 | 100 pF | $\pm 20\%$ | C6 | 1.0 μ F | $\pm 20\%$ |
| C2, C4 | 0.01 μ F | $\pm 20\%$ | C7 | 1.0 μ F | $\pm 20\%$ |

5.1.7 Programmable Anti-alias/image SC Filters

The anti-aliasing (AAF) and anti-imaging (AIF) switched capacitor (SC) filters have a programmable cut-off frequency to accommodate different input signal bandwidths. Typically, the audio filter bandwidth should be programmed to be $1/10^{\text{th}}$ of the ADM bit rate (or lower) for “toll” (or better) quality audio reconstruction. For “communications” quality, the audio bandwidth may approach $1/6^{\text{th}}$ of the ADM bit rate for ADM rates below 20kbps. The anti-alias/image SC filter bandwidth is programmed directly via C-BUS commands to the AAF/AIF BANDWIDTH Register (\$61). Additionally, the switched capacitor clock frequency can be altered via C-BUS commands to the CLK DIVIDER CONTROL Register (\$72). Typically, the CLK DIVIDER CONTROL Register should be programmed to provide a 256kHz SC filter clock. Altering the SC filter clock from the recommended 256kHz frequency proportionally scales the frequency axis in the plot below:

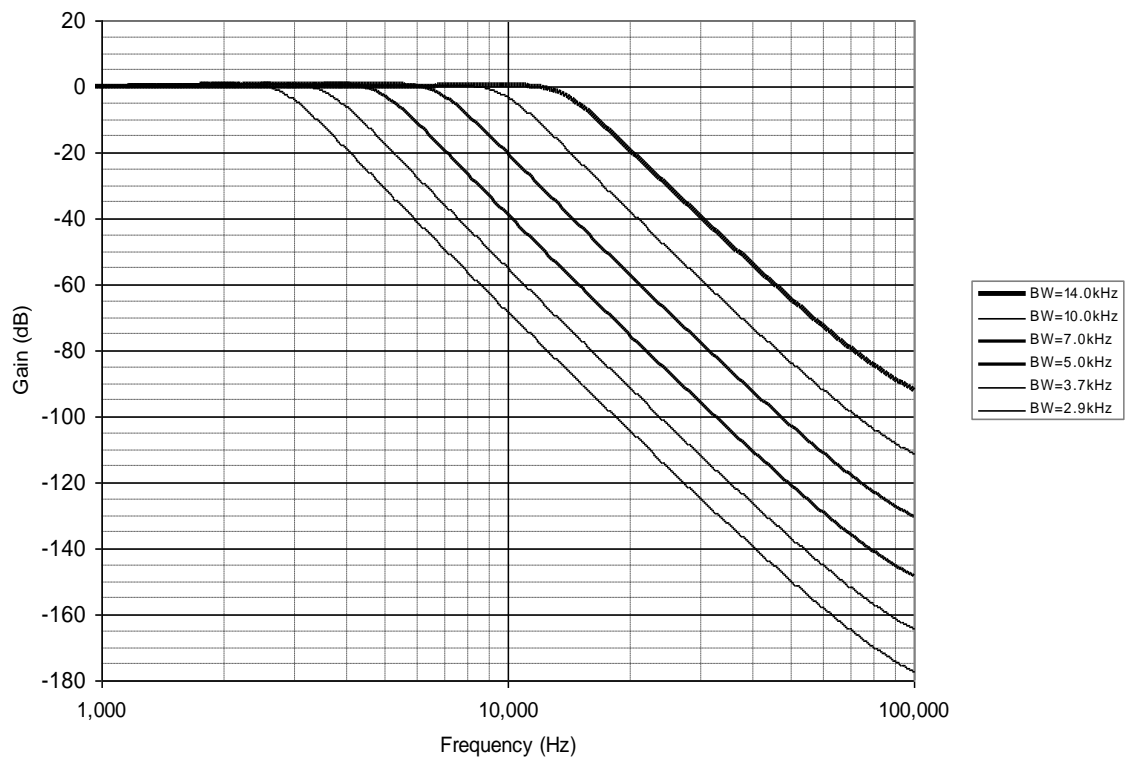

Figure 10a Typical Anti-Alias/Image Filter Frequency Response

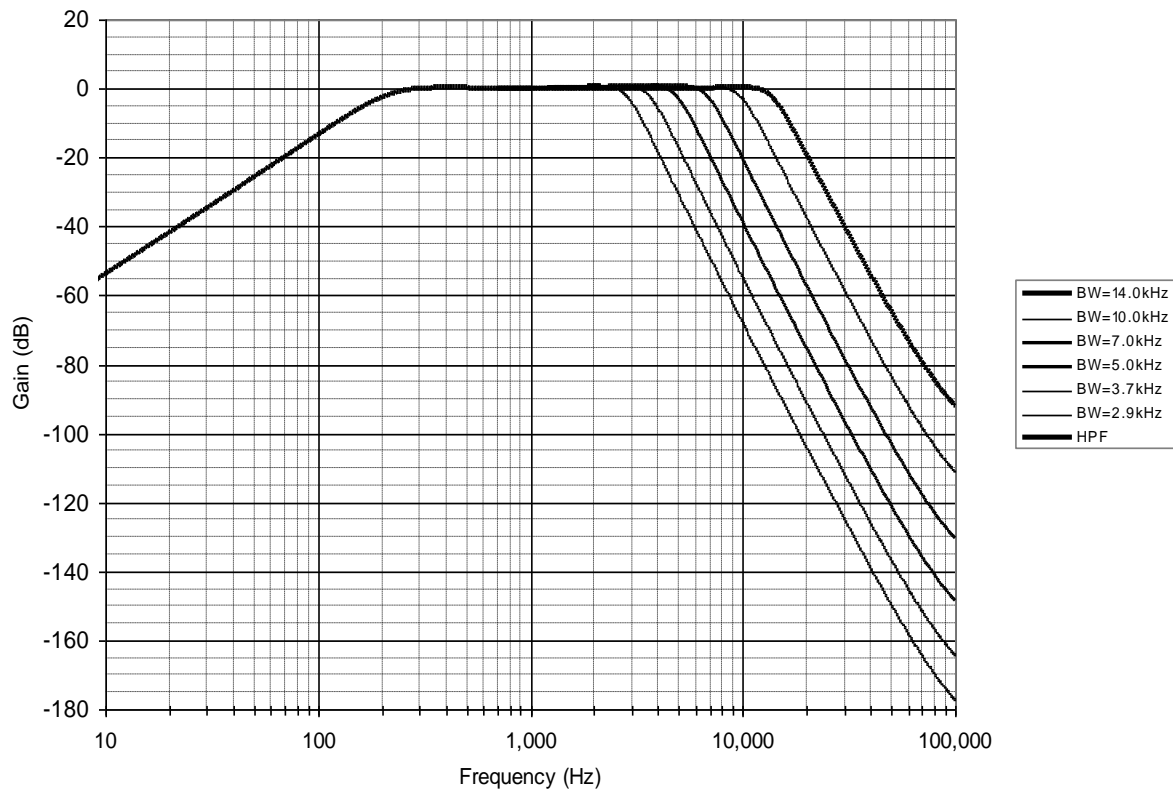

Figure 10b Typical Anti-Image Filter Frequency Response

5.1.8 Data Clock Recovery

Data from the RX DATA pin is driven into a comparator to remove amplitude variations. The output of the comparator is a logic signal that can be inverted by setting the appropriate control bit in the SCRAMBLER CONTROL Register (\$71). Using the output of the comparator, the clock recovery block can be enabled to generate a phase-locked clock equal to the CVSD data rate, which is used to clock data from the RX DATA pin into the decoder. The recovered clock frequency is controlled by the CLK DIVIDER CONTROL Register (\$72). If the clock recovery block is bypassed, data must then be applied which is synchronised to the clock on the RX CLK pin (either internally generated or externally applied).

External ADM rate bit clocks can be used for both the encoder and decoder paths and do not require use of the clock recovery PLL. Externally applied clocks act directly as the ADM sample clocks and should be generated with little jitter for best performance. Please note that the maximum usable frequency of externally applied bit clocks is $1/60^{\text{th}}$ of the frequency of the output of the internal bit clock prescaler.

The clock recovery circuit is normally applied to the decoder. However, it is possible to use the recovered clock for the encoder section as well. This supports systems where the base unit is using an internal clock or local external clock for transmit and clock recovery for the decoder clock. The remote unit can then be configured to use the recovered clock for both encode and decode. Internal data clocks for the encoder and decoder can also be selected for data input and output control.

5.1.9 Data Scrambler/De-scrambler

The scrambler receives digital data from the encoder. It is implemented with a 10-bit programmable linear feedback shift register (LFSR) allowing a choice of various maximal length scrambling codes. The scrambler, also known as a randomizer, provides not only a level of communication security, but may also help reduce the occurrence of abnormally long strings of 1s or 0s.

The de-scrambler receives the scrambled data from the data slicer and de-scrambles it to the original data as long as the selected LFSR maximal length sequence is the same as that in the transmitting scrambler. The de-scrambler block has the same configuration as the scrambler and is self-synchronizing. Both the scrambler and de-scrambler can be bypassed.

Nine example maximal length codes are represented below through their polynomial coefficients which can be directly programmed in Bits 9-0 of the SCRAMBLER CONTROL Register (\$71):

| Length | Polynomial coefficients in hex format |
|--------|---------------------------------------|
| 2 | 0x003 |
| 3 | 0x006 |
| 4 | 0x00C |
| 5 | 0x014 |
| 6 | 0x030 |
| 7 | 0x060 |
| 8 | 0x08E |
| 9 | 0x110 |
| 10 | 0x240 |

5.1.10 Voice Activity Detector (VAD)

The VAD function is implemented with an energy detector circuit. This circuit consists of an absolute value function, an integrator and a threshold detector. The threshold detector level and the integrator time constants (i.e. attack and decay time control) are user programmable via the DECODE and ENCODE VAD THRESHOLD Registers (\$D2 and \$E2) and the DECODER and ENCODER MODE AND SETUP Registers (\$D0 and \$E0). Referring to Figure 11, the input to the VAD comes from the PCM signal. The signal is rectified and averaged with a lossy integrator. The output of the integrator is compared to the VAD threshold to derive the logic signal VAD_OUT. If VAD_OUT is a logic one, signal energy greater than the threshold is present. If VAD_OUT is a logic zero, signal energy is below the threshold. When the VAD "trip" threshold has been reached, the amplitude required to clear this VAD state is set internally to half of the "trip" threshold. For example, if the VAD "trip" threshold is set to 100mV then the "clear" threshold will be 50mV. This hysteresis is provided to minimise chattering and is not user-adjustable. Attack and decay times for the decoder VAD and encoder VAD can be independently controlled via the DECODER and ENCODER MODE AND SETUP Registers (\$D0 and \$E0). Typical attack and decay times used for detecting voice activity are 5ms and 150ms, respectively. The energy levels may be read from DECODE and ENCODE VAD LEVEL OUTPUT Registers (\$D4 and \$E4) for the decoder and encoder and used to adaptively set the detector threshold value by observing the energy level of background noise.

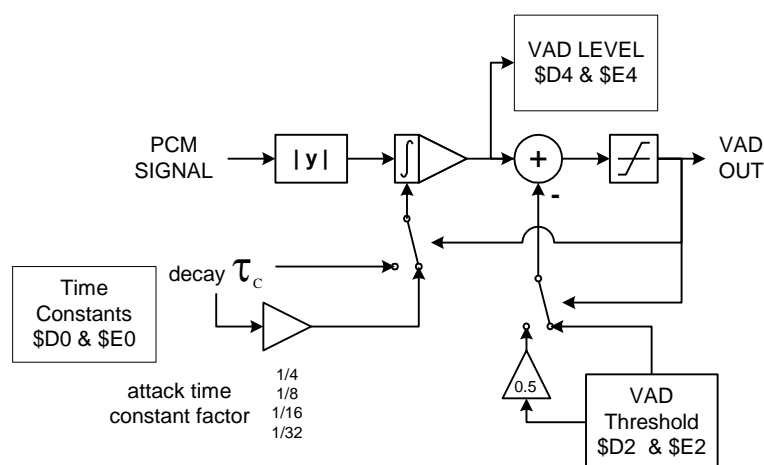

Figure 11 VAD Block Diagram

5.2 C-BUS Description

Address/Commands

Instructions and data are transferred, via C-BUS, in accordance with the timing information given in Figure 12.

Instruction and data transactions to and from the CMX649 consist of an Address/Command (A/C) byte followed by either:

- (i) a further instruction or data (1 or 2 bytes) or
- (ii) a status or Rx data reply (1 or 2 bytes)

Write Only C-BUS Registers

| REGISTER NAME | HEX ADDRESS/COMMAND | BIT 7 (D7) | BIT 6 (D6) | BIT 5 (D5) | BIT 4 (D4) | BIT 3 (D3) | BIT 2 (D2) | BIT 1 (D1) | BIT 0 (D0) |
|-------------------------|---------------------|----------------------|-------------------|---------------------------|-------------------|---------------------|--------------------------------------|-----------------|----------------|
| GENERAL RESET | \$01 | X | X | X | X | X | X | X | X |
| AAF/AIF BANDWIDTH | \$61 | Anti-Alias Filter | | | | Anti-Image Filter | | | |
| | | By-Pass | Band-Width | | | By-Pass | Band-Width | | |
| VOLUME/SIDE-TONE LEVEL | \$62 | Volume | | | | | Side-Tone | | ON/OFF |
| AUDIO INPUT LEVEL CTRL | \$63 | Input Level | | | | | 0 | 0 | 0 |
| POWER CONTROL 1 | \$64 | 0 | Anti-Alias Filter | 0 | Anti-Image Filter | Enc DAC Current | | Dec DAC Current | |
| POWER CONTROL 2 | \$65 | Mic Amp Current | | Audio Current | | Volume Current | | Xtal Current | Analog Enable |
| CODEC MODE CONTROL | \$70 | 0 | 0 | 0 | 0 | 0 | Codec Modes | | |
| SCRAMBLER CONTROL (1) | \$71 | SCRAMBLER | | | DE-SCRAMBLER | | | Polynomial | |
| | | EN | 0 | INVERT | EN | 0 | INVERT | T9 | T8 |
| (2) | | Polynomial | | | | | | | |
| | | T7 | T6 | T5 | T4 | T3 | T2 | T1 | T0 |
| CLK DIVIDER CONTROL (1) | \$72 | PREN | DCKEN | ECKEN | Filter Pre-Scaler | | Filter Divider | | |
| (2) | | Bit Clock Pre-Scaler | | Decoder Bit Clock Divider | | | Encoder Bit Clock Divider | | |
| CLK SOURCE CONTROL (1) | \$73 | 0 | 0 | Phase Detect Input Select | | 0 | 0 | 0 | 0 |
| (2) | | PLL EN | Rx Bit Clk Select | Tx Bit Clock Select | | Data Filter By-Pass | Data Filter and Slicer Power Control | | Data Filter BW |
| CODEC INTERRUPT CONTROL | \$81 | Encode Enable | | | | Decode Enable | | | |

| REGISTER NAME | HEX ADDRESS/ COMMAND | BIT 7 (D7) | BIT 6 (D6) | BIT 5 (D5) | BIT 4 (D4) | BIT 3 (D3) | BIT 2 (D2) | BIT 1 (D1) | BIT 0 (D0) |
|-----------------------------|----------------------|-------------------------------------------------------|---------------|------------|-----------------------------------------------|-----------------------------------------------------|-----------------------------|-------------------|----------------------|
| DECODER MODE AND SETUP (1) | \$D0 | DEC BY 4/8 | Select PCM IN | | Select ADM IN | | Decoder Output Select | | 0 |
| (2) | | VAD Decay Time Constant | | | VAD Attack Time Constant | Select VAD Output Source | | 0 | |
| DECODE ADM CONTROL (1) | \$D1 | Syllabic Time Constant | | | Dynamic Range for Step Size Integrator | | | Companding Rule | |
| (2) | | Estimator Integrator Principal Time Constant | | | 2 nd Order Estimator Time Constant | Zero location for 2 nd Order Integration | | Dec Zero | |
| DECODE VAD THRESHOLD (1) | \$D2 | Voice Activity Detector Threshold Setting Bits 15 - 8 | | | | | | | |
| (2) | | Voice Activity Detector Threshold Setting Bits 7 - 0 | | | | | | | |
| DECODE OFFSET LEVEL (1) | \$D3 | Offset Input Level Bits 15 - 8 | | | | | | | |
| (2) | | Offset Input Level Bits 7 - 0 | | | | | | | |
| DECODE LINEAR PCM INPUT (1) | \$D7 | Direct Write to DAC Input Bits 15 - 8 | | | | | | | |
| (2) | | Direct Write to DAC Input Bits 7 - 0 | | | | | | | |
| DECODE ADM INPUT | \$D8 | Decode ADM Input | | | | | | | |
| ENCODER MODE AND SETUP (1) | \$E0 | DEC BY 4/8 | Select PCM IN | | Select ADM IN | | Local Decoder Output Select | | Idle Channel Enhance |
| (2) | | VAD Decay Time Constant | | | VAD Attack Time Constant | Select VAD Output Source | | ADM Output Select | |
| ENCODE ADM CONTROL (1) | \$E1 | Syllabic Time Constant | | | Dynamic Range for Step Size Integrator | | | Companding Rule | |
| (2) | | Estimator Integrator Principal Time Constant | | | 2 nd Order Estimator Time Constant | Zero location for 2 nd Order Integration | | Dec Zero | |
| ENCODE VAD THRESHOLD (1) | \$E2 | Voice Activity Detector Threshold Setting Bits 15 - 8 | | | | | | | |
| (2) | | Voice Activity Detector Threshold Setting Bits 7 - 0 | | | | | | | |
| ENCODE OFFSET LEVEL (1) | \$E3 | Offset Input Level Bits 15 - 8 | | | | | | | |
| (2) | | Offset Input Level Bits 7 - 0 | | | | | | | |

| REGISTER NAME | HEX ADDRESS/ COMMAND | BIT 7 (D7) | BIT 6 (D6) | BIT 5 (D5) | BIT 4 (D4) | BIT3 (D3) | BIT 2 (D2) | BIT 1 (D1) | BIT 0 (D0) |
|----------------------|----------------------|---------------------------------------|------------|------------|------------|-----------|------------|------------|------------|
| ENCODE DAC INPUT (1) | \$E7 | Direct Write to DAC Input Bits 15 - 8 | | | | | | | |
| (2) | | Direct Write to DAC Input Bits 7 - 0 | | | | | | | |
| ENCODE ADM INPUT | \$E8 | Encode ADM Input | | | | | | | |

Read Only C-BUS Registers

| REGISTER NAME | HEX ADDRESS/ COMMAND | BIT 7 (D7) | BIT 6 (D6) | BIT 5 (D5) | BIT 4 (D4) | BIT3 (D3) | BIT 2 (D2) | BIT 1 (D1) | BIT 0 (D0) |
|--------------------------------|----------------------|--------------------------------------------------|------------|------------|------------|-------------------------|------------|------------|------------|
| CODEC STATUS (READ) | \$80 | Encode Process Status | | | | Decode Processor Status | | | |
| DECODE VAD LEVEL OUTPUT (1) | \$D4 | Voice Activity Detector Level Output Bits 15 - 8 | | | | | | | |
| (2) | | Voice Activity Detector Level Output Bits 7 - 0 | | | | | | | |
| DECODE OFFSET LEVEL OUTPUT (1) | \$D5 | Offset Level Output Bits 15 - 8 | | | | | | | |
| (2) | | Offset Level Output Bits 7 - 0 | | | | | | | |
| DECODE LINEAR PCM OUTPUT (1) | \$D6 | Linear PCM Output Signal Bits 15 - 8 | | | | | | | |
| (2) | | Linear PCM Output Signal Bits 7 - 0 | | | | | | | |
| DECODE ADM OUTPUT | \$DA | Decode ADM Output | | | | | | | |
| ENCODE VAD LEVEL OUTPUT (1) | \$E4 | Voice Activity Detector Level Output Bits 15 - 8 | | | | | | | |
| (2) | | Voice Activity Detector Level Output Bits 7 - 0 | | | | | | | |
| ENCODE OFFSET LEVEL OUTPUT (1) | \$E5 | Offset Level Output Bits 15 - 8 | | | | | | | |
| (2) | | Offset Level Output Bits 7 - 0 | | | | | | | |

| REGISTER NAME | HEX ADDRESS/ COMMAND | BIT 7 (D7) | BIT 6 (D6) | BIT 5 (D5) | BIT 4 (D4) | BIT3 (D3) | BIT 2 (D2) | BIT 1 (D1) | BIT 0 (D0) |
|------------------------------|----------------------|--------------------------------------|------------|------------|------------|-----------|------------|------------|------------|
| ENCODE LINEAR PCM OUTPUT (1) | \$E6 | Linear PCM Output Signal Bits 15 - 8 | | | | | | | |
| (2) | | Linear PCM Output Signal Bits 7 - 0 | | | | | | | |
| ENCODE ADM OUTPUT | \$EA | Encode ADM Output | | | | | | | |

5.2.1 Write Only Register Description

5.2.1.1 GENERAL RESET (\$01)

The reset command has no data attached to it. Application of the GENERAL RESET sets all write only register bits to 0.

5.2.1.2 AAF/AIF BANDWIDTH Register (\$61)

AAF Bypass (Bit 7) When this bit is set to logic 1 the anti-alias filter is bypassed.

AAF Bandwidth (Bits 6 – 4) The –3dB cutoff frequency of the anti-alias filter is controlled by bits 4 – 6. The filter shape is not altered other than to move the cutoff frequency.

| Bit 6 | Bit 5 | Bit 4 | -3dB Frequency |
|-------|-------|-------|----------------|
| 0 | 0 | 0 | 2.9kHz |
| 0 | 0 | 1 | 3.7kHz |
| 0 | 1 | 0 | 5.0kHz |
| 0 | 1 | 1 | 7.0kHz |
| 1 | 0 | 0 | 10.0kHz |
| 1 | 0 | 1 | 14.0kHz |

AIF Bypass (Bit 3) When this bit is set to a logic 1 the anti-image filter is bypassed.

AIF Bandwidth (Bits 2 – 0) The –3dB cutoff frequency of the anti-image filter is controlled by bits 0-2. The filter shape is not altered other than to move the cutoff frequency.

| Bit 2 | Bit 1 | Bit 0 | -3dB Frequency |
|-------|-------|-------|----------------|
| 0 | 0 | 0 | 2.9kHz |
| 0 | 0 | 1 | 3.7kHz |
| 0 | 1 | 0 | 5.0kHz |
| 0 | 1 | 1 | 7.0kHz |
| 1 | 0 | 0 | 10.0kHz |
| 1 | 0 | 1 | 14.0kHz |

5.2.1.3 VOLUME/SIDETONE LEVEL Register (\$62)

Volume Level (Bits 7 – 3) The five most significant bits in this register are used to set the gain of the volume control according to the table below:

| Bit 7 | Bit 6 | Bit 5 | Bit 4 | Bit 3 | Increment Per Step = 1.5dB Steps |
|-------|-------|-------|-------|-------|----------------------------------|
| 0 | 0 | 0 | 0 | 0 | Off |
| 0 | 0 | 0 | 0 | 1 | -33.0dB |
| 0 | 0 | 0 | 1 | 0 | -31.5dB |
| 0 | 0 | 0 | 1 | 1 | -30.0dB |
| 0 | 0 | 1 | 0 | 0 | -28.5dB |
| 0 | 0 | 1 | 0 | 1 | -27.0dB |
| 0 | 0 | 1 | 1 | 0 | -25.5dB |
| 0 | 0 | 1 | 1 | 1 | -24.0dB |
| 0 | 1 | 0 | 0 | 0 | -22.5dB |
| 0 | 1 | 0 | 0 | 1 | -21.0dB |
| 0 | 1 | 0 | 1 | 0 | -19.5dB |
| 0 | 1 | 0 | 1 | 1 | -18.0dB |
| 0 | 1 | 1 | 0 | 0 | -16.5dB |
| 0 | 1 | 1 | 0 | 1 | -15.0dB |
| 0 | 1 | 1 | 1 | 0 | -13.5dB |
| 0 | 1 | 1 | 1 | 1 | -12.0dB |
| 1 | 0 | 0 | 0 | 0 | -10.5dB |
| 1 | 0 | 0 | 0 | 1 | -9.0dB |
| 1 | 0 | 0 | 1 | 0 | -7.5dB |
| 1 | 0 | 0 | 1 | 1 | -6.0dB |
| 1 | 0 | 1 | 0 | 0 | -4.5dB |
| 1 | 0 | 1 | 0 | 1 | -3.0dB |
| 1 | 0 | 1 | 1 | 0 | -1.5dB |
| 1 | 0 | 1 | 1 | 1 | 0.0dB |
| 1 | 1 | 0 | 0 | 0 | 1.5dB |
| 1 | 1 | 0 | 0 | 1 | 3.0dB |
| 1 | 1 | 0 | 1 | 0 | 4.5dB |
| 1 | 1 | 0 | 1 | 1 | 6.0dB |
| 1 | 1 | 1 | 0 | 0 | 7.5dB |
| 1 | 1 | 1 | 0 | 1 | 9.0dB |
| 1 | 1 | 1 | 1 | 0 | 10.5dB |
| 1 | 1 | 1 | 1 | 1 | 12.0dB |

Sidetone Level (Bits 2 – 1) These bits control the gain of the sidetone signal coming from the AAF output to be summed in with the decode signal at the input to the AIF.

| Bit 2 | Bit 1 | Gain Setting |
|-------|-------|--------------|
| 0 | 0 | 0dB |
| 0 | 1 | -9dB |
| 1 | 0 | -15dB |
| 1 | 1 | -21dB |

Sidetone Enable (Bit 0) When this bit is a logic 1 the sidetone path is enabled with the gain setting controlled as shown above. When this bit is logic 0 the sidetone path is disabled.

5.2.1.4 AUDIO INPUT LEVEL CONTROL Register (\$63)

Audio Input Level Control (Bits 7 – 3)

These bits are used to set the gain of the Digitally Controlled Amplifier (DCA) at the output of the microphone amplifier.

| Bit 7 | Bit 6 | Bit 5 | Bit 4 | Bit 3 | Audio Input Gain |
|-------|-------|-------|-------|-------|------------------|
| 0 | 0 | 0 | 0 | 0 | Off |
| 0 | 0 | 0 | 0 | 1 | -7.5dB |
| 0 | 0 | 0 | 1 | 0 | -7.0dB |
| 0 | 0 | 0 | 1 | 1 | -6.5dB |
| 0 | 0 | 1 | 0 | 0 | -6.0dB |
| 0 | 0 | 1 | 0 | 1 | -5.5dB |
| 0 | 0 | 1 | 1 | 0 | -5.0dB |
| 0 | 0 | 1 | 1 | 1 | -4.5dB |
| 0 | 1 | 0 | 0 | 0 | -4.0dB |
| 0 | 1 | 0 | 0 | 1 | -3.5dB |
| 0 | 1 | 0 | 1 | 0 | -3.0dB |
| 0 | 1 | 0 | 1 | 1 | -2.5dB |
| 0 | 1 | 1 | 0 | 0 | -2.0dB |
| 0 | 1 | 1 | 0 | 1 | -1.5dB |
| 0 | 1 | 1 | 1 | 0 | -1.0dB |
| 0 | 1 | 1 | 1 | 1 | -0.5dB |
| 1 | 0 | 0 | 0 | 0 | 0.0dB |
| 1 | 0 | 0 | 0 | 1 | 0.5dB |
| 1 | 0 | 0 | 1 | 0 | 1.0dB |
| 1 | 0 | 0 | 1 | 1 | 1.5dB |
| 1 | 0 | 1 | 0 | 0 | 2.0dB |
| 1 | 0 | 1 | 0 | 1 | 2.5dB |
| 1 | 0 | 1 | 1 | 0 | 3.0dB |
| 1 | 0 | 1 | 1 | 1 | 3.5dB |
| 1 | 1 | 0 | 0 | 0 | 4.0dB |
| 1 | 1 | 0 | 0 | 1 | 4.5dB |
| 1 | 1 | 0 | 1 | 0 | 5.0dB |
| 1 | 1 | 0 | 1 | 1 | 5.5dB |
| 1 | 1 | 1 | 0 | 0 | 6.0dB |
| 1 | 1 | 1 | 0 | 1 | 6.5dB |
| 1 | 1 | 1 | 1 | 0 | 7.0dB |
| 1 | 1 | 1 | 1 | 1 | 7.5dB |

Reserved (Bits 2– 0)

These bits are reserved and should be set to a logic 0.

5.2.1.5 POWER CONTROL 1 Register (\$64)

AAF Power Control (Bit 7)

This bit is reserved and should be set to a logic 0

AAF Power Control (Bit 6)

This bit is dedicated to power/current control for the AAF. Note: It is necessary to keep the power level set to one of the “ON” settings when the AAF is bypassed.

| Bit 7 | Bit 6 | Power Level Setting |
|-------|-------|---------------------|
| 0 | 0 | Power down (Off). |
| 0 | 1 | Normal operation. |

AIF Power Control (Bit 5) This bit is reserved and should be set to a logic 0.

AIF Power Control (Bit 4) This bit is dedicated to power/current control for the AIF and the Sidetone DCA. Note: It is necessary to keep the power level set to one of the “ON” settings when the AIF is bypassed.

| Bit 5 | Bit 4 | Power Level Setting |
|-------|-------|---------------------|
| 0 | 0 | Power down (Off). |
| 0 | 1 | Normal operation. |

Encode DAC Power Control (Bits 3 – 2) These bits are dedicated to power/current control for the Encode DAC.

| Bit 3 | Bit 2 | Power Level Setting |
|-------|-------|-------------------------------------------------------|
| 0 | 0 | Power down (Off). |
| 0 | 1 | Lowest power (for bit rates less than 32kbps). |
| 1 | 0 | Low power (for bit rates between 32kbps and 64kbps). |
| 1 | 1 | Normal operation (for bit rates greater than 64kbps). |

Decode DAC Power Control (Bits 1 – 0) These bits are dedicated to power/current control for the Decode DAC.

| Bit 1 | Bit 0 | Power Level Setting |
|-------|-------|-------------------------------------------------------|
| 0 | 0 | Power down (Off). |
| 0 | 1 | Lowest power (for bit rates less than 32kbps). |
| 1 | 0 | Low power (for bit rates between 32kbps and 64kbps). |
| 1 | 1 | Normal operation (for bit rates greater than 64kbps). |

5.2.1.6 POWER CONTROL 2 Register (\$65)

MIC AMP Power Control (Bits 7 – 6) These bits are dedicated to power/current control for the Microphone Amplifier.

| Bit 7 | Bit 6 | Power Level Setting |
|-------|-------|-------------------------------------------------------------|
| 0 | 0 | Power down (Off). |
| 0 | 1 | Lowest power (for audio bandwidths less than 3.3kHz). |
| 1 | 0 | Low power (for bit rates between 3.3kHz and 10kHz). |
| 1 | 1 | Normal operation (for audio bandwidths greater than 10kHz). |

AUDIO DCA Power Control (Bits 5 – 4) These bits are dedicated to power/current control for the Audio Input Digitally Controlled Amplifier.

| Bit 5 | Bit 4 | Power Level Setting |
|-------|-------|-------------------------------------------------------------|
| 0 | 0 | Power down (Off). |
| 0 | 1 | Lowest power (for audio bandwidths less than 3.3kHz). |
| 1 | 0 | Low power (for audio bandwidths between 3.3kHz and 10kHz). |
| 1 | 1 | Normal operation (for audio bandwidths greater than 10kHz). |

VOLUME DCA Power Control (Bits 3 – 2) These bits are dedicated to power/current control for the Volume Digitally Controlled Amplifier.

| Bit 3 | Bit 2 | Power Level Setting |
|-------|-------|-------------------------------------------------------|
| 0 | 0 | Power down (Off). |
| 0 | 1 | Lowest power (for bit rates less than 32kbps). |
| 1 | 0 | Low power (for bit rates between 32kbps and 64kbps). |
| 1 | 1 | Normal operation (for bit rates greater than 64kbps). |

XTAL Power Save (Bit 1) When this bit is a logic 1 the one-pin crystal oscillator circuit is powered down.

ANALOG Enable (Bit 0) When this bit is set to a logic 1 all of the analog circuitry (register \$64 and bits 7-2 of register \$65) is enabled. When this bit is set to a logic 0 all of the analog circuitry is powered down (on-chip bandgap reference is powered down). This is equivalent to setting all of the bits of register \$64 and bits 7-2 of register \$65 to a logic 0. So to enable the AAF pabk, register \$64 bit 6 and register \$65 bit 0 must both be set to logic 1. Note that these bits control power to their respective blocks and that a signal path may still exist even if the block is powersaved.

5.2.1.7 CODEC MODE CONTROL Register (\$70)

Reserved (Bits 7 – 3) These bits are reserved and should be set to a logic 0.

CODEC MODE (Bits 2 – 0)

| Bit 2 | Bit 1 | Bit 0 | CODEC Mode |
|-------|-------|-------|----------------------------------|
| 0 | 0 | 0 | ADM mode without buffered I/O |
| 0 | 0 | 1 | ADM mode with buffered I/O |
| 0 | 1 | 0 | Linear PCM with buffered I/O |
| 0 | 1 | 1 | μ -law PCM with buffered I/O |
| 1 | 0 | 0 | A-law PCM with buffered I/O |

5.2.1.8 SCRAMBLER CONTROL Register (\$71)

Scrambler Enable (Bit 15) Setting this bit to a logic 1 enables the scrambler.

Reserved (Bit 14) Reserved for future use. Set to '0'.

Scrambler Output Invert (Bit 13) Setting this bit to a logic 1 inverts the scrambler output polarity.

De-Scrambler Enable (Bit 12) Setting this bit to a logic 1 enables the de-scrambler.

- Reserved (Bit 11)** Reserved for future use. Set to '0'.
- De-Scrambler Input Invert. (Bit 10)** Setting this bit to a logic 1 inverts the de-scrambler input polarity.
- LFSR Tap Select (Bits 9 – 0)** These bits directly program the polynomial for the scrambler and de-scrambler:
 $PR = B9X^9 + B8X^8 + B7X^7 + B6X^6 + B5X^5 + B4X^4 + B3X^3 + B2X^2 + B1X^1 + B0X^0$

5.2.1.9 CLK DIVIDER CONTROL Register (\$72)

- Pre-Scaler Enable (Bit 15)** Setting this bit to a logic 1 enables the pre-scaler divider.
- Decode Bit Clock Enable (Bit 14)** Setting this bit to a logic 1 enables the decode bit clock.
- Encode Bit Clock Enable (Bit 13)** Setting this bit to a logic 1 enables the encode bit clock.
- Filter Clock Pre-Scaler (Bits 12 – 11)** These bits control the internal switched capacitor (SC) filter clock pre-scaler.

| Bit 12 | Bit 11 | Divider Ratio |
|--------|--------|---------------|
| 0 | 0 | 1 |
| 0 | 1 | 2 |
| 1 | 0 | 3 |
| 1 | 1 | 4 |

- Filter Clock Divider (Bits 10 – 8)** These bits control the internal switched capacitor filter clock divider.

| Bit 10 | Bit 9 | Bit 8 | Divider Ratio |
|--------|-------|-------|---------------|
| 0 | 0 | 0 | 2.000 |
| 0 | 0 | 1 | 8.000 |
| 0 | 1 | 0 | 15.500 |
| 0 | 1 | 1 | 15.750 |
| 1 | 0 | 0 | 16.000 |
| 1 | 0 | 1 | 22.000 |
| 1 | 1 | 0 | 31.250 |
| 1 | 1 | 1 | 46.750 |

Bit Clock Pre-Scaler These bits control the bit clock pre-scaler.
(Bits 7 – 6)

| Bit 7 | Bit 6 | Divider Ratio |
|-------|-------|---------------|
| 0 | 0 | 1 |
| 0 | 1 | 2 |
| 1 | 0 | 3 |
| 1 | 1 | 4 |

Decode Bit Clock Divider These bits control the decode bit clock divider.
(Bits 5 – 3)

| Bit 5 | Bit 4 | Bit 3 | Divider Ratio |
|-------|-------|-------|---------------|
| 0 | 0 | 0 | 1.000 |
| 0 | 0 | 1 | 2.000 |
| 0 | 1 | 0 | 2.250 |
| 0 | 1 | 1 | 2.625 |
| 1 | 0 | 0 | 3.000 |
| 1 | 0 | 1 | 3.125 |
| 1 | 1 | 0 | 3.375 |
| 1 | 1 | 1 | 3.500 |

Encode Bit Clock Divider These bits control the encode bit clock divider.
(Bits 2 – 0)

| Bit 2 | Bit 1 | Bit 0 | Divider Ratio |
|-------|-------|-------|---------------|
| 0 | 0 | 0 | 1.000 |
| 0 | 0 | 1 | 2.000 |
| 0 | 1 | 0 | 2.250 |
| 0 | 1 | 1 | 2.625 |
| 1 | 0 | 0 | 3.000 |
| 1 | 0 | 1 | 3.125 |
| 1 | 1 | 0 | 3.375 |
| 1 | 1 | 1 | 3.500 |

The CLK DIVIDER CONTROL Register should be programmed to provide a 256kHz nominal SC filter clock. Programming the SC filter clock to different frequencies will introduce a proportionate frequency shift in the configured anti-alias/image SC filter frequency responses. See also section 6.3.

The audio filter clock divider should be programmed to set the audio filter clock as near as possible to 256kHz, via selection of the XTAL frequency and the Filter Prescaler and Filter Divider settings.

The encoder and decoder ADM bit rate clocks should be programmed to the desired ADM bit rate or PCM sample rate, multiplied by the interpolation/decimation setting of the PCM filter. The PCM filter can be programmed to run at either 4x or 8x the PCM sample rate depending on the corresponding setting in the encode/decode processors.

The encoder and decoder ADM bit rate clocks are further divided by a constant factor of 64 (unless the PLL is enabled in which case the average is near 64 but can pull off slightly depending on the reference source).

5.2.1.10 CLK SOURCE CONTROL Register (\$73)

Reserved
(Bits 15-14) These bits are reserved and should be set to a logic 0.

**Phase Detect
Input Select**
(Bit 13) 0 = PLL locks to external input clock
1 = PLL locks to external input strobe.

(Bit 12) 0 = PLL locks to data edges.
1 = PLL locks to external clock or strobe edges according to Bit 13 value.

Reserved
(Bits 11-10) These bits are reserved and should be set to a logic 0.

**TX Data Pad Tri-
State control**
(Bit 9) 0=TX DATA pin always driven by device.
1=in buffered I/O mode the TX DATA pin is driven only when valid data is present after the strobe pulse.

Reserved
(Bit 8) This bit is reserved and should be set to a logic 0.

PLL Enable
(Bit 7) Setting this bit to a logic 1 enables the phase locked loop in the clock recover circuit. When the PLL is enabled the decoder ADM bit clock adjusts its phase in increments of 1/32 of the programmed period to minimise noise due to timing jitter. Setting this bit to a logic 0 free-wheels the post divide by 64 decode clock divider and thus produces a bit clock which is synchronised to the XTAL/CLK input.

**Decode Bit
Clock Select**
(Bit 6) Setting this bit to a logic 1 selects the bit clock generated by the clock recovery circuit. Setting this bit to a logic 0 selects a bit clock externally applied to the RX CLK pin.

**Encode Bit
Clock Select**
(Bits 5 – 4) These bits allow for the selection of three different sources for the encode bit clock.

| Bit 5 | Bit 4 | Encode Bit Clock |
|-------|-------|-----------------------------------------|
| X | 0 | External Tx Clock Pin. |
| 0 | 1 | Internally Generated encode clock. |
| 1 | 1 | Internally Generated from decode clock. |

Note that a system clock or crystal is always required on the XTAL/CLK pin, in order to generate the various internal timing signals, even when Rx and Tx Clocks are recovered from the RX DATA pin.

**Data Filter
Bypass**
(Bit 3) Setting this bit to a logic 1 bypasses the data filter and inputs the RX DATA signal directly into the data slicer.

Data Filter and Slicer Power Control (Bits 2 – 1) These bits are dedicated to power/current control for the data filter and slicer.

| Bit 2 | Bit 1 | Power Level Setting |
|-------|-------|-------------------------------------------------------|
| 0 | 0 | Power down (Off). |
| 0 | 1 | Lowest power (for bit rates less than 32kbps). |
| 1 | 0 | Low power (for bit rates between 32kbps and 64kbps). |
| 1 | 1 | Normal operation (for bit rates greater than 64kbps). |

When the Data Filter and Slicer are powered off, the RX DATA input pin signal must conform to logic level amplitudes. When operating the device in buffered I/O modes, the Data Filter and Slicer should be powered off.

Data Filter Bandwidth (Bit 0) Setting this bit to a logic 1 forces the data filter to narrow bandwidth mode.

5.2.1.11 CODEC INTERRUPT CONTROL Register (\$81)

Encoder Control (Bits 7 – 4)

| Bit 7 | Bit 6 | Bit 5 | Bit 4 | Encoder Setting |
|-------|-------|-------|-------|--------------------------------------------------------------------------------------------------------------------------|
| 0 | X | X | X | Encoder is disabled and reset. |
| 1 | 0 | 0 | 0 | Encoder is enabled to run without generating IRQs. |
| 1 | 1 | X | X | Encoder is enabled and will generate IRQs to indicate VAD status changes. |
| 1 | X | 1 | X | Encoder is enabled and will generate periodic IRQs to indicate whether PCM data is available or needed when transcoding. |
| 1 | X | X | 1 | Encoder is enabled and will generate periodic IRQs to indicate whether ADM data is available or needed when transcoding. |

Decoder Control (Bits 3 – 0)

| Bit 3 | Bit 2 | Bit 1 | Bit 0 | Decoder Setting |
|-------|-------|-------|-------|------------------------------------------------------------------------------------------------------------------------------|
| 0 | X | X | X | Decoder is disabled and reset. |
| 1 | 0 | 0 | 0 | Decoder is enabled to run without generating IRQs. |
| 1 | 1 | X | X | Decoder is enabled and will generate IRQs to indicate VAD status changes. |
| 1 | X | 1 | X | Decoder is enabled and will generate periodic IRQs to indicate whether the PCM data is needed or available when transcoding. |
| 1 | X | X | 1 | Decoder is enabled and will generate periodic IRQs to indicate whether the ADM data is needed or available when transcoding. |

5.2.1.12 DECODER MODE AND SETUP Register (\$D0)

Decimation Rate (by 4/8) (Bit 15)

The decoder PCM filter functions as an interpolator for the DAC when PCM words are being received by the decoder and as a decimator when the decoder is receiving delta modulation. In the case where delta modulation is received, transcoded PCM values are available in the DECODE LINEAR PCM OUTPUT Register (\$D6) at the decimation rate. When PCM is received the device can be set to transcode to an ADM stream available in the DECODE ADM OUTPUT Register (\$DA) at the interpolated rate. A logic 1 sets the interpolation (decimation) rate to 4 (1/4th the bit rate). A logic 0 sets the interpolation (decimation) rate to 8 (1/8th the bit rate).

PCM Input Select (Bits 14 – 13)

Allows selection of the input to the PCM rate converting filter.

| Bit 14 | Bit 13 | Selected PCM Input |
|--------|--------|----------------------------------------------------------------------------------------------------------------------------------------------------------------------------------------------------------------------------------------------------------------------------------|
| 0 | X | PCM filter decimates ADM estimator output. PCM words available in register \$D6. |
| 1 | 0 | PCM filter interpolates linear PCM input from burst mode interface (RX DATA pin). This selection must be made in conjunction with the CODEC MODE CONTROL Register (\$70). Note that the burst interface expands μ Law or Alaw signals to linear PCM prior to the PCM filter. |
| 1 | 1 | PCM filter interpolates linear PCM input from C-BUS interface via the DECODE LINEAR PCM INPUT Register (\$D7). |

If PCM filter interpolates, the decoder can digitally transcode a PCM signal to ADM. If PCM filter decimates, the decoder can digitally transcode an ADM signal to PCM.

ADM Input Select (Bits 12 – 11)

| Bit 12 | Bit 11 | Selected ADM Input |
|--------|--------|------------------------------------------------------------------------------------------------------------------------------------------------------------------------------------------------------------------------------------------------------------------------------------------------------|
| 0 | 0 | ADM decoder input from the RX DATA pin. (Normal mode operation). |
| 0 | 1 | ADM decoder gets input from C-BUS via the DECODE ADM INPUT Register (\$D8). This could be used to force in an idle pattern or to play out an arbitrary stored signal. (Alternate ADM input operation). |
| 1 | X | ADM input from digital feedback. When ADM input comes from digital feedback it will transcode from PCM to ADM. PCM filter must be set to interpolate. In this mode the analog interface can be powered down since all signal processing is done digitally. (PCM to ADM transcoding input operation). |

Decoder Output Select (Bits 10 – 9)

| Bit 10 | Bit 9 | Selected Decoder Output |
|--------|-------|---------------------------------------------------------------------------------------------------------------------------------------------------------------------------------------------|
| 0 | 0 | ADM estimator output drives decoder output. |
| 0 | 1 | ADM estimator output summed with PCM interpolation filter output drives decoder output. The ADM and PCM signals can be input from any combination of RX DATA pin and C-BUS input registers. |
| 1 | 0 | Direct PCM test mode. |
| 1 | 1 | Interpolated PCM output. |

Reserved (Bit 8) This bit is reserved and should be set to a logic 0.

Decoder VAD Decay Time Constant (Bits 7 – 5) Allows selection of the Voice Activity Detector decay time constant.

| Bit 7 | Bit 6 | Bit 5 | Decay Time Constant (ms), Bit Rate in kbps |
|-------|-------|-------|-----------------------------------------------|
| 0 | 0 | 0 | 128/(Bit Rate) |
| 0 | 0 | 1 | 256/(Bit Rate) |
| 0 | 1 | 0 | 512/(Bit Rate) |
| 0 | 1 | 1 | 1024/(Bit Rate) |
| 1 | 0 | 0 | 2048/(Bit Rate) |
| 1 | 0 | 1 | 4096/(Bit Rate) |
| 1 | 1 | 0 | 8192/(Bit Rate) |
| 1 | 1 | 1 | 16384/(Bit Rate) |

Decoder VAD Attack Time Constant (Bits 4 – 3) Allows selection of the Voice Activity Detector attack time constant.

| Bit 4 | Bit 3 | Attack Time Constant (ms) |
|-------|-------|------------------------------|
| 0 | 0 | (VAD Decay Time Constant)/4 |
| 0 | 1 | (VAD Decay Time Constant)/8 |
| 1 | 0 | (VAD Decay Time Constant)/16 |
| 1 | 1 | (VAD Decay Time Constant)/32 |

Decoder VAD Output Source (Bits 2 – 1) Allows selection of the Voice Activity Detector output source.

| Bit 2 | Bit 1 | VAD Output |
|-------|-------|-----------------------------------------------------------------------------------------------------------------------------------------------|
| 0 | 0 | Normal VAD operation. |
| 0 | 1 | ADM bits are driven over VAD pin at the ADM bit rate (may be useful when transcoding or verifying proper application of the burst interface). |
| 1 | 0 | VAD output driven to 0. |
| 1 | 1 | VAD output driven to 1. |

Reserved (Bit 0) This bit is reserved and should be set to a logic 0.

5.2.1.13 DECODE ADM CONTROL Register (\$D1)

Syllabic Time Constant (Bits 15 – 13) Step size integrator Loss Coefficient: allows selection of syllabic time constant.

| Bit 15 | Bit 14 | Bit 13 | Syllabic Filter Time Constant (ms) |
|--------|--------|--------|-------------------------------------------------------------------|
| 0 | 0 | 0 | 512/(3*Bit Rate) |
| 0 | 0 | 1 | 768/(3*Bit Rate) |
| 0 | 1 | 0 | 1024/(3*Bit Rate) |
| 0 | 1 | 1 | 1536/(3*Bit Rate) |
| 1 | 0 | 0 | 2048/(3*Bit Rate) |
| 1 | 0 | 1 | 3072/(3*Bit Rate) Bluetooth compatible when running at 64kbps. |
| 1 | 1 | 0 | 4096/(3*Bit Rate) |
| 1 | 1 | 1 | 6144/(3*Bit Rate) |

**Dynamic Range
for Step Size
Integrator
(Bits 12 – 10)**

Maximum and minimum step size are based on 16-bit word length (-32768 to 32767).

| Bit 12 | Bit 11 | Bit 10 | Maximum Step | Minimum Step |
|--------|--------|--------|--------------|-------------------------------------------------|
| 0 | 0 | 0 | 10240 | 20 |
| 0 | 0 | 1 | 10240 | 10 |
| 0 | 1 | 0 | 5120 | 20 |
| 0 | 1 | 1 | 5120 | 10 |
| 1 | 0 | 0 | 2560 | 20 |
| 1 | 0 | 1 | 2560 | 10 |
| 1 | 1 | 0 | 1280 | 20 |
| 1 | 1 | 1 | 1280 | 10 |
| | | | | Bluetooth compatible when running at 64kbps. |

**Companding
Rule
(Bits 9 – 8)**

This is the number of consecutive ones or zeros that must occur for the step size to be adjusted.

| Bit 9 | Bit 8 | Companding Rule |
|-------|-------|-----------------------------------------------------------|
| 0 | 0 | 3 of 3 |
| 0 | 1 | 4 of 4 Bluetooth compatible when running at 64kbps. |
| 1 | 0 | 5 of 5 |
| 1 | 1 | 6 of 6 |

**Estimator
Integrator Time
Constant
(Bits 7 – 5)**

Allows selection of the estimator integrator time constant.

| Bit 7 | Bit 6 | Bit 5 | Decay Time Constant (ms) |
|-------|-------|-------|--------------------------------------------------------------------|
| 0 | 0 | 0 | 16/(3*Bit Rate) |
| 0 | 0 | 1 | 24/(3*Bit Rate) |
| 0 | 1 | 0 | 32/(3*Bit Rate) |
| 0 | 1 | 1 | 48/(3*Bit Rate) |
| 1 | 0 | 0 | 64/(3*Bit Rate) |
| 1 | 0 | 1 | 96/(3*Bit Rate) Bluetooth compatible when running at 64kbps. |
| 1 | 1 | 0 | 128/(3*Bit Rate) |
| 1 | 1 | 1 | 192/(3*Bit Rate) |

**Second Order
Estimator Time
Constant
(Bits 4 – 3)**

Allows selection of the second order estimator time constant.

| Bit 4 | Bit 3 | Time Constant (ms), Bit Rate in kbps |
|-------|-------|--------------------------------------|
| 0 | 0 | N/A (selects first order estimator). |
| 0 | 1 | (Estimator Time Constant)/2 |
| 1 | 0 | (Estimator Time Constant)/4 |
| 1 | 1 | (Estimator Time Constant)/8 |

**Zero Selection
(Bits 2 – 1)**

When second order integration is used, a zero can be inserted to help encoder stability. Not generally used in the decoder unless set to digitally transcode from PCM to ADM.

| Bit 2 | Bit 1 | Time Constant (ms), Bit Rate in kbps |
|-------|-------|-----------------------------------------|
| 0 | 0 | N/A (select for first order estimator). |
| 0 | 1 | 1.5/Bit Rate |
| 1 | 0 | 2.5/Bit Rate |
| 1 | 1 | 4.5/Bit Rate |

Zero at ½ Bit Rate (Bit 0) When decoding ADM, a zero at (bit rate)/2 can be enabled by setting this bit to logic 1. When transcoding from PCM to ADM this bit should always be set to logic 0 to avoid instability in the transcoding loop.

5.2.1.14 DECODE VAD THRESHOLD Register (\$D2)

Decode VAD Threshold (Bits 15 – 0) These bits directly program the threshold of detection for the Voice Activity Detector. The number programmed into this register can range from \$0 to \$7FFF (0 to 32767). The equation for the VAD threshold is:

$$\text{Register Value} = \frac{(\text{Signal Detection Threshold}) \cdot 2^{15}}{(\text{DAC Full Scale Reference Voltage})}$$

5.2.1.15 DECODE OFFSET LEVEL Register (\$D3)

Decode Offset Input (Bits 15 – 0) For normal Decoder operation this register should be set to logic 0.

These bits allow for an offset amount to be directly programmed. This offset amount is useful in trimming out offsets that may occur in the on-chip analog circuitry. The number format is 2's complement and ranges from \$8000 through \$0000 to \$7FFF (-32768 to 32767).

The equation for the Offset value is:

$$\text{Register Value} = \frac{(\text{Offset Voltage}) \cdot 2^{18}}{(\text{DAC Full Scale Reference Voltage})}$$

The programmed offset will be summed with the decoder output signal.

5.2.1.16 DECODE LINEAR PCM INPUT Register (\$D7)

Decode Linear PCM Input (Bits 15 – 0) This register allows input of linear PCM via C-BUS for transcoding. The number format is 2's complement and ranges from \$8000 through \$0000 to \$7FFF (-32768 to 32767). Bit 1 of the CODEC INTERRUPT CONTROL Register (\$81) can be set to a logic 1 to enable interrupts informing a micro-controller when the register should be updated.

5.2.1.17 DECODE ADM INPUT Register (\$D8)

Decoder ADM Input (Bits 7 – 0) This register allows ADM bits to be written into the decoder via C-BUS and is intended for transcoding. Bit 0 of the CODEC INTERRUPT CONTROL Register (\$81) can be set to a logic 1 to enable interrupts informing a micro-controller when the register should be updated. Additionally this register can be loaded with an idle data pattern (\$55 or \$AA) and then selected as the input to the decoder via the DECODER MODE AND SETUP Register (\$D0).

5.2.1.18 ENCODER MODE AND SETUP Register (\$E0)

Decimation Rate (by 4/8) (Bit 15)

The encoder PCM filter functions as a decimating lowpass when the encoder is running. PCM values are available in the ENCODE LINEAR PCM OUTPUT Register (\$E6) at the decimation rate. A logic 1 sets the decimation rate to 4 (1/4th the bit rate). A logic 0 sets the decimation rate to 8 (1/8th the bit rate).

PCM Input Select (Bits 14 – 13)

Allows selection of the input to the PCM rate converting filter.

| Bit 14 | Bit 13 | Selected PCM Input |
|--------|--------|--------------------------------------------------------------------------------------------------------------------------------------------------------------------|
| 0 | X | PCM filter decimates ADM estimator output PCM words available in register \$E6. |
| 1 | 0 | PCM filter interpolates PCM input from burst mode interface (RX DATA pin). This selection must be made in conjunction with the CODEC MODE CONTROL Register (\$70). |
| 1 | 1 | PCM filter interpolates PCM input from C-BUS interface via the ENCODE DAC TEST CONTROL Register (\$E7). |

If PCM filter is interpolating, the encoder can transcode a PCM signal to ADM. If PCM filter is decimating, the encoder will transcode an ADM signal to PCM.

ADM Input Select (Bits 12 – 11)

| Bit 12 | Bit 11 | Selected ADM Input |
|--------|--------|--------------------------------------------------------------------------------------------------------------------------------------------------------------------------------------------------------------------------------------------------------------------------------------------|
| 0 | 0 | ADM encoder input from Comparator. (Normal mode operation). |
| 0 | 1 | ADM encoder gets input from C-BUS breaking the feedback loop and allowing the local decoder to digitally transcode an ADM signal input via C-BUS to a PCM signal output via C-BUS or the burst interface. (Alternate ADM input operation). |
| 1 | X | ADM input from transcode feedback. When ADM input comes from transcode feedback it will transcode from PCM to ADM. The PCM filter must be set to interpolate. In this mode the encode analog interface can be powered down since it is not used. (PCM to ADM transcoding input operation). |

Local Decoder Output Select (Bits 10 – 9)

| Bit 10 | Bit 9 | Selected Local Decoder Output |
|--------|-------|----------------------------------------------------------------------------------------------------------------------------------------------------------------------------------------------------------------------|
| 0 | 0 | ADM estimator output drives local decoder output. |
| 0 | 1 | ADM estimator output summed with PCM interpolation filter output drives local decoder output. For encoder, ADM output tracks sum of MIC input analog signal plus a PCM signal input over the C-BUS interface. |
| 1 | 0 | Direct PCM test mode. |
| 1 | 1 | Interpolated PCM output. |

Idle Channel Enhance (Bit 8)

This bit improves the perceived low-level sound quality by enabling the automatic tracking of offsets, which reduces internal offset levels. Some increase in harmonic distortion may result from the use of this bit. If automatic compensation is not required, this bit should be set to logic 0 and the ENCODE OFFSET LEVEL Register (\$E3) should also be set to logic 0. This bit should normally be set to a logic 1 to allow analog offsets to be automatically compensated.

When running the encoder as a digital ADM to PCM transcoder this bit should be set to 0 since the local ADM decoder runs outside a feedback loop.

When enabling offset compensation, ensure the encoder ADM input selection is set either for feedback from the comparator or for PCM to ADM transcoding. Also load the ENCODE OFFSET LEVEL Register (\$E3) with a small positive constant. If transcode feedback is selected then the PCM filter must also be set to interpolate.

Encoder VAD Decay Time Constant (Bits 7 – 5)

These bits allow selection of the Voice Activity Detector decay time constant.

| Bit 7 | Bit 6 | Bit 5 | Decay Time Constant (ms), Bit Rate in kbps |
|-------|-------|-------|--------------------------------------------|
| 0 | 0 | 0 | 128/(Bit Rate) |
| 0 | 0 | 1 | 256/(Bit Rate) |
| 0 | 1 | 0 | 512/(Bit Rate) |
| 0 | 1 | 1 | 1024/(Bit Rate) |
| 1 | 0 | 0 | 2048/(Bit Rate) |
| 1 | 0 | 1 | 4096/(Bit Rate) |
| 1 | 1 | 0 | 8192/(Bit Rate) |
| 1 | 1 | 1 | 16384/(Bit Rate) |

Encoder VAD Attack Time Constant (Bits 4 – 3)

Allows selection of the Voice Activity Detector attack time constant.

| Bit 4 | Bit 3 | Attack Time Constant (ms) |
|-------|-------|------------------------------|
| 0 | 0 | (VAD Decay Time Constant)/4 |
| 0 | 1 | (VAD Decay Time Constant)/8 |
| 1 | 0 | (VAD Decay Time Constant)/16 |
| 1 | 1 | (VAD Decay Time Constant)/32 |

Encoder VAD Output Source (Bits 2 – 1)

Allows selection of the Voice Activity Detector output source.

| Bit 2 | Bit 1 | VAD Output |
|-------|-------|-----------------------------------------------------------------------------------------------------------------------------------------------|
| 0 | 0 | Nominal VAD operation. |
| 0 | 1 | ADM bits are driven over VAD pin at the ADM bit rate (may be useful when transcoding or verifying proper application of the burst interface). |
| 1 | 0 | VAD output driven to 0. |
| 1 | 1 | VAD output driven to 1. |

ADM Output Select (Bit 0)

For normal operation this bit should be set to a logic 0. Setting this bit to a logic 1 allows arbitrary ADM streams, written in via the ENCODE ADM INPUT Register (\$E8), to be output. For example to force the encoder to output an idle pattern 010101... while running, regardless of the input analog waveform, write \$55 into register \$E8 and set this bit to a logic 1.

5.2.1.19 ENCODE ADM CONTROL Register (\$E1)

Syllabic Time Constant (Bits 15 – 13)

Step size integrator Loss Coefficient: allows selection of syllabic time constant.

| Bit 15 | Bit 14 | Bit 13 | Syllabic Filter Time Constant (ms), Bit Rate in kbps |
|--------|--------|--------|----------------------------------------------------------------------|
| 0 | 0 | 0 | 512/(3*Bit Rate) |
| 0 | 0 | 1 | 768/(3*Bit Rate) |
| 0 | 1 | 0 | 1024/(3*Bit Rate) |
| 0 | 1 | 1 | 1536/(3*Bit Rate) |
| 1 | 0 | 0 | 2048/(3*Bit Rate) |
| 1 | 0 | 1 | 3072/(3*Bit Rate) Bluetooth compatible when running at 64kbps. |
| 1 | 1 | 0 | 4096/(3*Bit Rate) |
| 1 | 1 | 1 | 6144/(3*Bit Rate) |

Dynamic Range for Step Size Integrator

Numbers given for maximum and minimum step size are based on 16-bit word length (-32768 to 32767).

Step Size Integrator (Bits 12 – 10)

| Bit 12 | Bit 11 | Bit 10 | Maximum Step | Minimum Step |
|--------|--------|--------|--------------|-------------------------------------------------------|
| 0 | 0 | 0 | 10240 | 20 |
| 0 | 0 | 1 | 10240 | 10 |
| 0 | 1 | 0 | 5120 | 20 |
| 0 | 1 | 1 | 5120 | 10 |
| 1 | 0 | 0 | 2560 | 20 |
| 1 | 0 | 1 | 2560 | 10 |
| 1 | 1 | 0 | 1280 | 20 |
| 1 | 1 | 1 | 1280 | 10 Bluetooth compatible when running at 64kbps. |

Companding Rule (Bits 9 – 8)

This is the number of consecutive ones or zeros that must occur for the step size to be adjusted.

| Bit 9 | Bit 8 | Companding Rule |
|-------|-------|-----------------------------------------------------------|
| 0 | 0 | 3 of 3 |
| 0 | 1 | 4 of 4 Bluetooth compatible when running at 64kbps. |
| 1 | 0 | 5 of 5 |
| 1 | 1 | 6 of 6 |

Estimator Integrator Time Constant (Bits 7 – 5)

Allows selection of the estimator integrator time constant.

| Bit 7 | Bit 6 | Bit 5 | Decay Time Constant (ms), Bit Rate in kbps |
|-------|-------|-------|--------------------------------------------------------------------|
| 0 | 0 | 0 | 16/(3*Bit Rate) |
| 0 | 0 | 1 | 24/(3*Bit Rate) |
| 0 | 1 | 0 | 32/(3*Bit Rate) |
| 0 | 1 | 1 | 48/(3*Bit Rate) |
| 1 | 0 | 0 | 64/(3*Bit Rate) |
| 1 | 0 | 1 | 96/(3*Bit Rate) Bluetooth compatible when running at 64kbps. |
| 1 | 1 | 0 | 128/(3*Bit Rate) |
| 1 | 1 | 1 | 192/(3*Bit Rate) |

Second Order Estimator Time Constant (Bits 4 – 3)

Allows selection of the second order estimator time constant.

| Bit 4 | Bit 3 | Loss Factor |
|-------|-------|--------------------------------------|
| 0 | 0 | N/A (selects first order estimator). |
| 0 | 1 | (Estimator Time Constant)/2 |
| 1 | 0 | (Estimator Time Constant)/4 |
| 1 | 1 | (Estimator Time Constant)/8 |

Zero Selection (Bits 2 – 1)

When second order integration is used, a zero can be inserted to help stability.

| Bit 2 | Bit 1 | Time Constant (ms), Bit Rate in kbps |
|-------|-------|----------------------------------------|
| 0 | 0 | N/A (select for first order estimator) |
| 0 | 1 | 1.5/Bit Rate |
| 1 | 0 | 2.5/Bit Rate |
| 1 | 1 | 4.5/Bit Rate |

Zero at ½ Bit Rate (Bit 0)

When decoding ADM, a zero at (bit rate)/2 can be enabled by setting this bit to logic 1. When encoding or transcoding from PCM to ADM this bit should always be set to a logic 0 to avoid instability of the ADM feedback loop.

5.2.1.20 ENCODE VAD THRESHOLD Register (\$E2)**Encode VAD Threshold (Bits 15 – 0)**

These bits directly program the threshold of detection for the Voice Activity Detector. The number programmed into this register can range from \$0 to \$7FFF (0 to 32767). The equation for the VAD threshold is:

$$\text{Register Value} = \frac{(\text{Signal Detection Threshold}) \cdot 2^{15}}{(\text{DAC Full Scale Reference Voltage})}$$

5.2.1.21 ENCODE OFFSET LEVEL Register (\$E3)**Encode Offset Input (Bits 15 - 0)**

These bits allow for an offset amount to be directly programmed. This offset amount is useful in trimming out offsets that may occur in the on-chip analog circuitry. The number format is 2's complement and ranges from \$8000 through \$0000 to \$7FFF (-32768 to 32767).

The equation for the direct offset value is:

$$\text{Register Value} = \frac{(\text{Offset Voltage}) \cdot 2^{18}}{(\text{DAC Full Scale Reference Voltage})}$$

For normal Encoder operation this register should be loaded with a small positive constant (eg in the range [2-16]) and bit 8 of the ENCODER MODE AND SETUP Register (\$E0) should be set to logic 1. The programmed offset will be summed with the encoder input signal. If offset compensation is not required, bit 8 of the register \$E0 should be set to logic 0 and the ENCODE OFFSET LEVEL Register should also be set to logic 0.

Offset compensation can be suspended by loading this register with 0 while leaving Bit 8 of register \$E0 true. This holds the current offset estimate constant. The offset estimate can be read out via the ENCODE OFFSET LEVEL OUTPUT Register (\$E5).

5.2.1.22 ENCODE DAC INPUT Register (\$E7)

Encode DAC Input (Bits 15 – 0) This register allows direct access to the encoder DAC input. The number format is 2's complement and ranges from \$8000 through \$0000 to \$7FFF (-32768 to 32767).

5.2.1.23 ENCODE ADM INPUT TEST Register (\$E8)

Encoder ADM Input Test (Bits 7 – 0) This register allows ADM bits to be written via C-BUS for transcoding from ADM to PCM. An interrupt can be enabled to inform a micro-controller when the register needs reloading.

5.2.2 Read Only Register Description

5.2.2.1 PROCESSOR STATUS READ Register (\$80)

Reading this STATUS register clears any pending IRQ. The PCM and ADM data available and data needed flags (bits 5, 4, 1 and 0 respectively) are cleared when the appropriate CBUS register is read (or written), in order to service the IRQ. The VAD detection flags (bits 6 and 2) are constantly updated to indicate the status of voice activity. Any change in state of either flag will cause an IRQ to be generated.

Encoder Status (Bits 7 – 4) Bit 7 is permanently set to logic 0.
 A logic 1 in Bit 6 indicates Voice Activity is detected.
 A logic 1 in Bit 5 indicates PCM data is available (or needed when transcoding)
 A logic 1 in Bit 4 indicates ADM samples are available (or needed when transcoding).

Decoder Status (Bits 3 – 0) Bit 3 is permanently set to logic 0.
 A logic 1 in Bit 2 indicates Voice Activity is detected.
 A logic 1 in Bit 1 indicates PCM data is needed (or available when transcoding).
 A logic 1 in Bit 0 indicates ADM samples are needed (or available when transcoding).

5.2.2.2 DECODE VAD LEVEL OUTPUT READ Register (\$D4)

Decode VAD Level Output (Bits 15 – 0) These bits indicate the average amplitude of the envelope of the audio signal. This negative 2's complement number can range from \$0 to \$8000 (0 to -32768 and can be used to assist in calculating an appropriate value to be programmed into the DECODE VAD THRESHOLD Register (\$D2). The equation for the VAD level register value is:

$$\text{Register Value} = \frac{-1 \cdot (\text{Envelope Voltage Level}) \cdot 2^{15}}{(\text{DAC Full Scale Reference Voltage})}$$

5.2.2.3 DECODE OFFSET LEVEL OUTPUT READ Register (\$D5)

Decode Offset Level Output (Bits 15 – 0) These bits indicate offset level as input by the user in register \$D3. The number format is 2's complement and ranges from \$8000 through \$0000 to \$7FFF (-32768 to 32767).

The equation for the offset value is:

$$\text{Register Value} = \frac{(\text{Offset Voltage}) \cdot 2^{18}}{(\text{DAC Full Scale Reference Voltage})}$$

5.2.2.4 DECODE LINEAR PCM OUTPUT READ Register (\$D6)

Decode Linear PCM Output (Bits 15 – 0) This register contains the linear PCM equivalent of the ADM or non-linear PCM input signal. The number format is 2's complement and ranges from \$8000 through \$0000 to \$7FFF (-32768 to 32767). Bit 1 of the CODEC INTERRUPT CONTROL Register (\$81) can be set to a logic 1 to enable interrupts, informing a micro-controller when the register has been updated.

The equation for the PCM register value is:

$$\text{Register Value} = \frac{(\text{PCM voltage}) \cdot 2^{15}}{(\text{DAC Full Scale Reference Voltage})}$$

5.2.2.5 DECODE ADM OUTPUT READ Register (\$DA)

Decode ADM Output (Bits 7 – 0) This register allows ADM bits to be read via C-BUS and is updated every eighth bit. Bit 0 of the CODEC INTERRUPT CONTROL Register (\$81) can be set to a logic 1 to enable interrupts, informing a micro-controller when the register has been updated. When the decoder is set to transcode from PCM to ADM the ADM bits are available via this register.

5.2.2.6 ENCODE VAD LEVEL OUTPUT READ Register (\$E4)

Encode VAD Level Output (Bits 15 – 0) These bits indicate the average amplitude of the envelope of the audio signal. This negative 2's complement number can range from \$0 to \$8000 (0 to -32768) and can be used to assist in calculating an appropriate value to be programmed into the ENCODE VAD THRESHOLD Register (\$E2).

The equation for the VAD level register value is:

$$\text{Register Value} = \frac{-1 \cdot (\text{Envelope Voltage Level}) \cdot 2^{15}}{(\text{DAC Full Scale Reference Voltage})}$$

5.2.2.7 ENCODE OFFSET LEVEL OUTPUT READ Register (\$E5)

Encode Offset Level Output (Bits 15 – 0) These bits indicate the offset level as input by the user in register \$E3, which is dynamically updated if Idle Channel Enhance is enabled. The number format is 2's complement and ranges from \$8000 through \$0000 to \$7FFF (-32768 to 32767). It can be used as an appropriate value to be programmed into the ENCODE OFFSET LEVEL Register (\$E3) if offset compensation will be disabled.

The equation for the offset value is:

$$\text{Register Value} = \frac{(\text{Offset Voltage}) \cdot 2^{18}}{(\text{DAC Full Scale Reference Voltage})}$$

5.2.2.8 ENCODE LINEAR PCM OUTPUT READ Register (\$E6)

Encode Linear PCM Output (Bits 15 – 0) This register contains the linear PCM equivalent of the encoded ADM signal. The number format is 2's complement and ranges from \$8000 through \$0000 to \$7FFF (-32768 to 32767). Bit 5 of the CODEC INTERRUPT CONTROL Register (\$81) can be set to a logic 1 to enable interrupts, informing a micro-controller when the register has been updated.

The equation for the PCM register value is:

$$\text{Register Value} = \frac{(\text{PCM voltage}) \cdot 2^{15}}{(\text{DAC Full Scale Reference Voltage})}$$

5.2.2.9 ENCODE ADM OUTPUT READ Register (\$EA)

Encode ADM Output Test (Bits 7 – 0) This register allows Encoder ADM bits to be read via C-BUS and is updated every eighth bit. Bit 4 of the CODEC INTERRUPT CONTROL Register (\$81) can be set to a logic 1 to enable interrupts, informing a micro-controller when the register has been updated.

6. Application Notes

6.1 C-BUS Operation

Instructions, status and data are transferred between the CMX649 and the host μ C over the C-BUS. Instruction and data transfers to and from the CMX649 consist of an Address/Command (A/C) byte followed by either:

1. a further instruction or
2. 1 or 2 bytes of data (write) or
3. 1 or 2 bytes of status or received data reply (read).

The number of data bytes following an A/C byte is dependent on the value of the A/C byte. The most significant bit of the address or data is sent first. The C-BUS SERIAL_CLOCK input to the CMX649 originates from the host μ C.

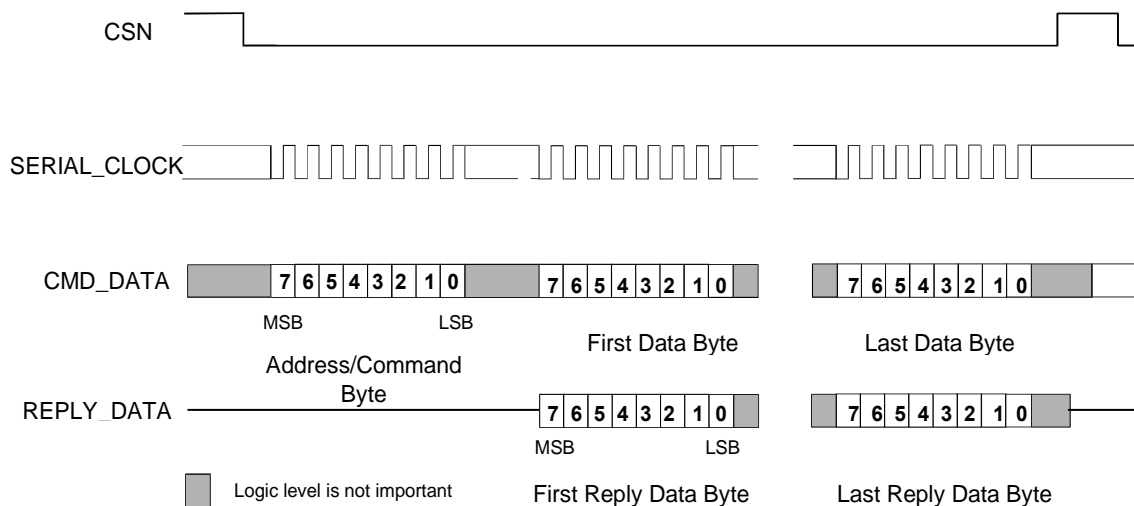

Figure 12 C-BUS Timing Diagram

6.2 CODEC Data Interface

The CMX649 encodes analog audio signals into digital samples, which can be decoded back to analog audio signals. The number of bits per sample is determined by the coding algorithm, which is selected using register \$70, CODEC MODE CONTROL. For the ADM coding algorithm, one bit represents one sample and the linear PCM coding algorithm uses 16 bits to represent one sample. The A-law and μ -law PCM algorithms use 8 bits to represent one sample.

The CMX649 CODEC Data Interface is a digital interface responsible for transferring Rx samples into, and Tx samples out of, the device. The interface can be operated in one of two modes: buffered or unbuffered. This selection is made when using the CODEC MODE CONTROL register to choose the coding algorithm.

In burst mode, also called buffered mode, the device will buffer (hold) a data word (either 8 or 16 bits depending on the operating mode) until it is transferred in for processing or out to the listening device. Burst mode requires two timing signals to be furnished by a controlling device: Sync (STRB Pin 1) and Clock (Rx Clk Pin 12). Tx and Rx clocks are tied together internally for burst mode and are driven by the Rx Clk pin. There is only one sync input.

In non-burst mode the device transfers data one bit at a time and only one timing signal is required, Clock. The clock signal can be produced by the CMX649 or supplied by the controlling device. The Tx and Rx clocks can be separate or the same.

The clocking choices of the CMX649 are very flexible. Please refer to the application note: *CMX649 Operation and Application*, for related detail.

Burst Mode

| Function | Characteristic | Description |
|-------------------------|-----------------------------|------------------------------------------------------|
| Burst_CLK frequency | 5MHz | Maximum Rate Rx Clk, Pin 12 |
| Data word length | 8 or 16 bits | |
| Linear PCM | 16 bits | 16 bit 2's complement word |
| A-Law or u-Law | 8 bits | One sign bit, a 3-bit exponent and a 4-bit mantissa. |
| ADM | 8 bits | One sample per bit, 8 samples per data word |
| SYNC Delay | 0 Burst CLKs | Continuous Clocking allowed |
| SYNC Length | 1 to (data word length – 1) | Burst Clock Periods |
| Words (slots) per frame | 1 | Single sample per slot |
| Slot start references | from SYNC | STRB, Pin 1 |

| Line | Direction | Start at Clk | Data Transition Edge | Transmission Order | Data Word Length and Byte Order |
|---------|-----------|--------------|----------------------|--------------------|---------------------------------|
| TX_DATA | Output | 1 | rise | msb first | 8 or 16 bits (m.s. byte first) |
| RX_DATA | Input | 1 | rise | msb first | 8 or 16 bits (m.s. byte first) |

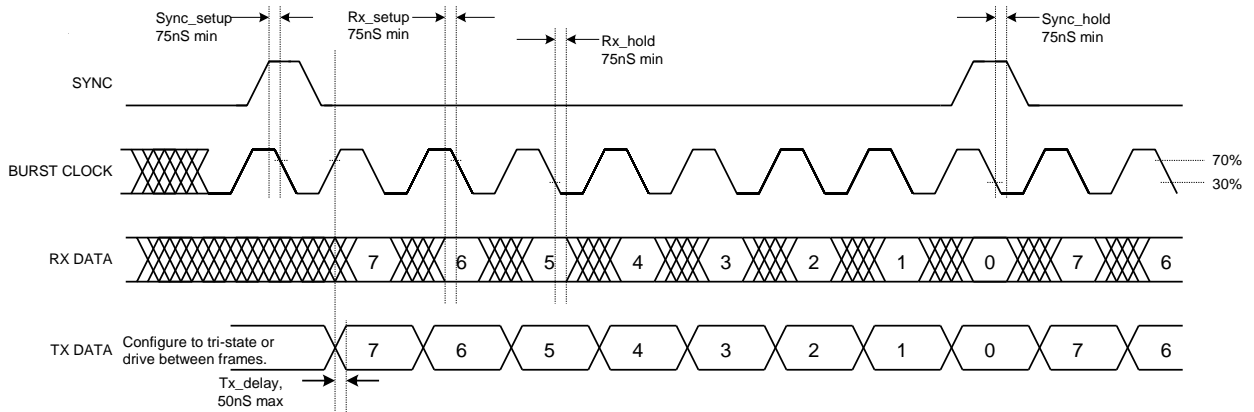

Figure 13 Burst Interface Timing Diagram for Concatenated Byte Transfers

Notes for Figure 13:

- In this example Bit 7 is the most significant bit.
- Once started Rx and Tx data bits are continuously streaming so long as the SYNC pulse continues at the PCM sample rate (for PCM modes) or at 1/8th the data rate for ADM modes.
- Configuration options support some variations of this timing diagram, e.g. data word length, without affecting the timing shown.
- The TX_DATA output may be high impedance between burst frames depending on bit 9 of CLK SOURCE CONTROL Register (\$73).
- In ADM mode Data length is 1 bit. Frames are 8 bits in length.

Non-Burst Mode

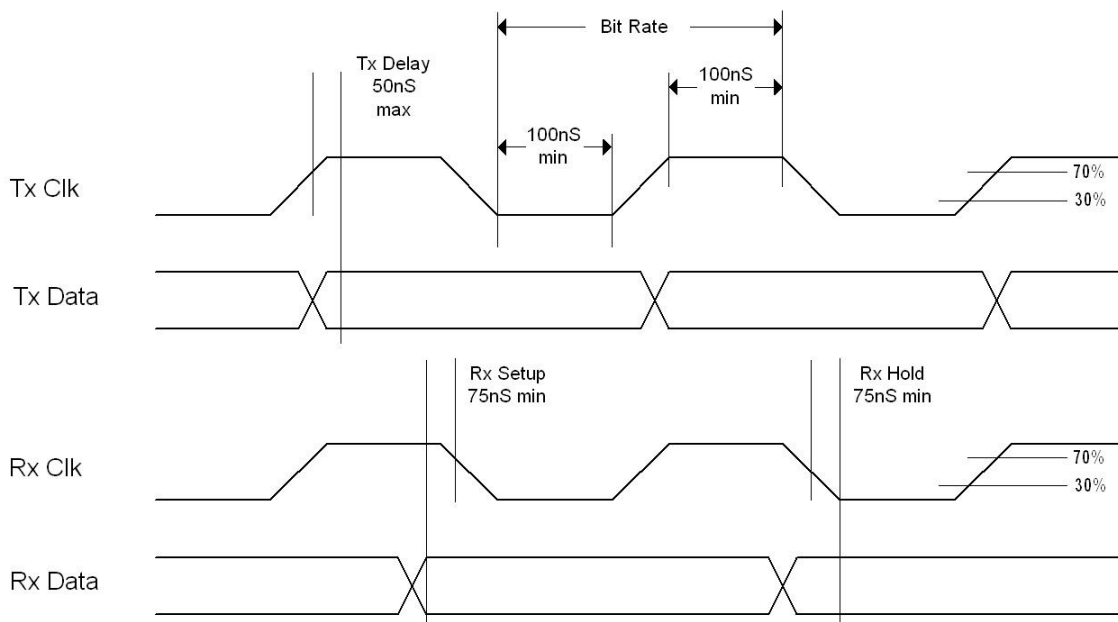

Figure 14 Burst Interface Timing Diagram for Concatenated Byte Transfers

Notes for Figure 14:

- Tx and Rx clocks don't need to be the same rate or phase but the Rx data rate must be at the same rate with which the data was encoded.
- Tx and Rx bit clocks can be internally generated by the CMX649 clock generator section, or they can be supplied from external sources.
- ADM is the only un-buffered mode possible.
- Duty cycle constraints shown for Tx Clk also apply to Rx Clk.

6.3 Example CODEC Setups and Application Help

Below are tabulated some applicable settings for the CLK DIVIDER CONTROL Register (\$72). Note that the minimum crystal frequency that can be used is 8.000 MHz, frequencies below this require the use of an external clock source.

| Audio Switched Capacitor Filter Clock Settings (clock frequency in kHz) | | | | | | | | | |
|---------------------------------------------------------------------------------------------|-----------------|-------------------------------------------------|---------|---------|---------|---------|---------|---------|---------|
| Crystal vs Audio Filter Divider Chart for CMX649 Yielding the Recommended ~256kHz SCF Clock | | | | | | | | | |
| Crystal or external clock Freq MHz | Prescaler Value | Divider values | 8 | 15.5 | 15.75 | 16 | 22 | 31.25 | 47.75 |
| | | Register bits clk ctrl[10:8] clk ctrl[12:11] | 001 | 010 | 011 | 100 | 101 | 110 | 111 |
| 2.048 | 1 | 00 | 256.000 | | | | | | |
| 4 | 1 | 00 | | 258.065 | 253.968 | | | | |
| 4.032 | 1 | 00 | | | 256.000 | | | | |
| 4.096 | 1 | 00 | | | | 256.000 | | | |
| 8 | 1 | 00 | | | | | | 256.000 | |
| 8.064 | 2 | 01 | | | 256.000 | | | | |
| 8.192 | 2 | 01 | | | | 256.000 | | | |
| 11.2896 | 2 | 01 | | | | | 256.582 | | |
| 12 | 1 | 00 | | | | | | | 256.684 |
| 12.096 | 3 | 10 | | | 256.000 | | | | |
| 12.288 | 3 | 10 | | | | 256.000 | | | |
| 16 | 2 | 01 | | | | | | 256.000 | |
| 16.128 | 4 | 11 | | | 256.000 | | | | |
| 16.384 | 4 | 11 | | | | 256.000 | | | |

When selecting divider settings to arrive at a desired bit rate from a given crystal frequency, note that some power savings are realized by selecting a lower divider value in conjunction with a higher prescaler value, thus minimizing the frequency of the prescaler output.

| Bit Rate (kbps) Settings with Bit Rate Prescaler = 1 Crystal vs Divider chart for CMX649 | | | | | | | | | |
|---------------------------------------------------------------------------------------------|-----------------------------------------|---------|--------|--------|--------|--------|--------|--------|--------|
| Crystal or external clock Freq MHz | Divider values | 1 | 2 | 2.25 | 2.625 | 3 | 3.125 | 3.375 | 3.5 |
| | Register bits clk ctrl[5:3] [2:0] | | | | | | | | |
| | clk ctrl[7:6] | 000 | 001 | 010 | 011 | 100 | 101 | 110 | 111 |
| 4 | 00 | 62.500 | 31.250 | 27.778 | 23.810 | 20.833 | 20.000 | 18.519 | 17.857 |
| 4.032 | 00 | 63.000 | 31.500 | 28.000 | 24.000 | 21.000 | 20.160 | 18.667 | 18.000 |
| 4.096 | 00 | 64.000 | 32.000 | 28.444 | 24.381 | 21.333 | 20.480 | 18.963 | 18.286 |
| 8 | 00 | 125.000 | 62.500 | 55.556 | 47.619 | 41.667 | 40.000 | 37.037 | 35.714 |
| 8.064 | 00 | 126.000 | 63.000 | 56.000 | 48.000 | 42.000 | 40.320 | 37.333 | 36.000 |
| 8.192 | 00 | 128.000 | 64.000 | 56.889 | 48.762 | 42.667 | 40.960 | 37.926 | 36.571 |

| Applicable Bit Rate (kbps) Settings with Bit Rate Prescaler = 2 Crystal vs Divider chart for CMX649 | | | | | | | | | |
|--------------------------------------------------------------------------------------------------------|-----------------------------------------|---------|--------|--------|--------|--------|--------|--------|--------|
| Crystal or external clock Freq MHz | Divider values | 1 | 2 | 2.25 | 2.625 | 3 | 3.125 | 3.375 | 3.5 |
| | Register bits clk ctrl[5:3] [2:0] | | | | | | | | |
| | clk ctrl[7:6] | 000 | 001 | 010 | 011 | 100 | 101 | 110 | 111 |
| 4 | 01 | 31.250 | 15.625 | | | | | | |
| 4.032 | 01 | 31.500 | 15.750 | | | | | | |
| 4.096 | 01 | 32.000 | 16.000 | | | | | | |
| 8 | 01 | 62.500 | 31.250 | 27.778 | 23.810 | 20.833 | 20.000 | 18.519 | 17.857 |
| 8.064 | 01 | 63.000 | 31.500 | 28.000 | 24.000 | 21.000 | 20.160 | 18.667 | 18.000 |
| 8.192 | 01 | 64.000 | 32.000 | 28.444 | 24.381 | 21.333 | 20.480 | 18.963 | 18.286 |
| 11.2896 | 01 | 88.200 | 44.100 | 39.200 | 33.600 | 29.400 | 28.224 | 26.133 | 25.200 |
| 12 | 01 | 93.750 | 46.875 | 41.667 | 35.714 | 31.250 | 30.000 | 27.778 | 26.786 |
| 12.096 | 01 | 94.500 | 47.250 | 42.000 | 36.000 | 31.500 | 30.240 | 28.000 | 27.000 |
| 12.288 | 01 | 96.000 | 48.000 | 42.667 | 36.571 | 32.000 | 30.720 | 28.444 | 27.429 |
| 16 | 01 | 125.000 | 62.500 | 55.556 | 47.619 | 41.667 | 40.000 | 37.037 | 35.714 |
| 16.128 | 01 | 126.000 | 63.000 | 56.000 | 48.000 | 42.000 | 40.320 | 37.333 | 36.000 |
| 16.384 | 01 | 128.000 | 64.000 | 56.889 | 48.762 | 42.667 | 40.960 | 37.926 | 36.571 |

| Applicable Bit Rate (kbps) Settings with Bit Rate Prescaler = 3 Crystal vs Divider chart for CMX649 | | | | | | | | | |
|--------------------------------------------------------------------------------------------------------|-----------------------------------------|--------|--------|--------|--------|--------|--------|--------|--------|
| Crystal or external clock Freq MHz | Divider values | 1 | 2 | 2.25 | 2.625 | 3 | 3.125 | 3.375 | 3.5 |
| | Register bits clk ctrl[5:3] [2:0] | 000 | 001 | 010 | 011 | 100 | 101 | 110 | 111 |
| | clk ctrl[7:6] | | | | | | | | |
| 4 | 10 | 20.833 | | | | | | | |
| 4.032 | 10 | 21.000 | | | | | | | |
| 4.096 | 10 | 21.333 | | | | | | | |
| 8 | 10 | 41.667 | 20.833 | 18.519 | 15.873 | | | | |
| 8.064 | 10 | 42.000 | 21.000 | 18.667 | 16.000 | | | | |
| 8.192 | 10 | 42.667 | 21.333 | 18.963 | 16.254 | | | | |
| 11.2896 | 10 | 58.800 | 29.400 | 26.133 | 22.400 | 19.600 | 18.816 | 17.422 | 16.800 |
| 12 | 10 | 62.500 | 31.250 | 27.778 | 23.810 | 20.833 | 20.000 | 18.519 | 17.857 |
| 12.096 | 10 | 63.000 | 31.500 | 28.000 | 24.000 | 21.000 | 20.160 | 18.667 | 18.000 |
| 12.288 | 10 | 64.000 | 32.000 | 28.444 | 24.381 | 21.333 | 20.480 | 18.963 | 18.286 |
| 16 | 10 | 83.333 | 41.667 | 37.037 | 31.746 | 27.778 | 26.667 | 24.691 | 23.810 |
| 16.128 | 10 | 84.000 | 42.000 | 37.333 | 32.000 | 28.000 | 26.880 | 24.889 | 24.000 |
| 16.384 | 10 | 85.333 | 42.667 | 37.926 | 32.508 | 28.444 | 27.307 | 25.284 | 24.381 |

| Applicable Bit Rate (kbps) Settings with Bit Rate Prescaler = 4 Crystal vs Divider chart for CMX649 | | | | | | | | | |
|--------------------------------------------------------------------------------------------------------|-----------------------------------------|--------|--------|--------|--------|--------|--------|--------|--------|
| Crystal or external clock Freq MHz | Divider values | 1 | 2 | 2.25 | 2.625 | 3 | 3.125 | 3.375 | 3.5 |
| | Register bits clk ctrl[5:3] [2:0] | 000 | 001 | 010 | 011 | 100 | 101 | 110 | 111 |
| | clk ctrl[7:6] | | | | | | | | |
| 4 | 11 | 15.625 | | | | | | | |
| 4.032 | 11 | 15.750 | | | | | | | |
| 4.096 | 11 | 16.000 | | | | | | | |
| 8 | 11 | 31.250 | 15.625 | | | | | | |
| 8.064 | 11 | 31.500 | 15.750 | | | | | | |
| 8.192 | 11 | 32.000 | 16.000 | | | | | | |
| 11.2896 | 11 | 44.100 | 22.050 | 19.600 | 16.800 | | | | |
| 12 | 11 | 46.875 | 23.438 | 20.833 | 17.857 | 15.625 | 15.000 | | |
| 12.096 | 11 | 47.250 | 23.625 | 21.000 | 18.000 | 15.750 | 15.120 | | |
| 12.288 | 11 | 48.000 | 24.000 | 21.333 | 18.286 | 16.000 | 15.360 | | |
| 16 | 11 | 62.500 | 31.250 | 27.778 | 23.810 | 20.833 | 20.000 | 18.519 | 17.857 |
| 16.128 | 11 | 63.000 | 31.500 | 28.000 | 24.000 | 21.000 | 20.160 | 18.667 | 18.000 |
| 16.384 | 11 | 64.000 | 32.000 | 28.444 | 24.381 | 21.333 | 20.480 | 18.963 | 18.286 |

6.3.1 32kbps ADM with clock and data recovery

```

//Initialize device with general reset
// This powers down everything excluding the xtal oscillator circuit
$01
//Setup analog section
// $61 00 filters set for 2.9kHz BW (default after reset)
// volume=0dB side_tone=-21dB and off
$62 $BE
// audio_level=0dB
$63 $80
// power_control everything on (lowest current setting)
$64 $55
$65 $55
// codec mode
// default $70 $00 ADM unbuffered (continuous bit serial mode)
// Clock Divider Control
// using 8.192MHz master clock
// filter clock prescale/=4 main divider/=8 => 256kHz SCF clock
// bit clock prescale/=4 encode and decode bit dividers/=1 since constant divider/=64 => 32kbps
$72 $F9 $C0
// PLL is off, Bypass PLL Data Filter and Power it Down
// Internal Decode and Encode clocks from
// Decode internal clock
$73 $00 $78
// setup decoder
// decimate by 8
// decode adm input from RX Data
// adm estimator drives output
// vad attack tc=4ms and decay tc=128ms
// normal vad outputs
$D0 $00 $B8
// adm encode feedback from comparator, nulling for improved idle - otherwise as decoder
$E0 $01 $B8
// to enable offset nulling load small positive constant into encoder offset input reg
$E3 $00 $04
// adm mode syllabic tc=16ms
// step size dynamic range 5120/10
// companding rule = 4 of 4
// principal tc=0.33ms
// second order tc=0.083ms
// encoder zero tc=0.047ms decoder zero tc=N/A
// decoder zero at 16kHz i.e. bit_rate/2 enabled
$D1 $6D $51
$E1 $6D $52
// vad thresholds ~20mv
$D2 $02 $00
$E2 $02 $00
// prime idle pattern into CBUS ADM source byte regs
$D8 $AA
$E8 $AA
//Scrambler and Descrambler both on, using polynomial $14 (5 bit LFSR)
$71 $90 $14
// enable encoder and decoder with no IRQs
$81 $88
// note some useful register changes from the above settings
// force encoder to output an idle pattern ($E0 $81 $B9) (requires $E8 $AA above)
// force decoder to idle via idling its input ($D0 $88 $B8) (requires $D8 $AA above)
// force decoder to mute output via direct PCM out ($D0 $86 $B8) (reset default has $D7 $00 $00)
// turn Scrambler and Descrambler off ($71 $00 $00)
// To Make PLL run with input from data pad
// internal RX and TX clocks
// RX data input acting as analog input i.e. data filter and data slicer running
// ($73 $00 $D2)

```

6.3.2 64kbps burst mode Bluetooth Compatible CVSD

```

//Initialize device with general reset
// This powers down everything excluding the xtal oscillator circuit
$01
//Setup analog section
// $61 00 filters set for 2.9kHz BW (default after reset)
// volume=0dB side_tone=-21dB and on
$62 $BF
// audio_level=0dB
$63 $80
// power_control everything on (lowest current setting)
$64 $55
$65 $55
// codec mode ADM buffered (burst bytes at 1/8 bit rate mode)
$70 $01
// Clock Divider Control
// with 8.192MHz master clock
// filter clock prescale/=4 main divider/=8 => 256kHz SCF clock
// bit clock prescale/=2 main divider/=1 since constant divider/=64 always => 64kHz bit clocks
$72 $F9 $40
// PLL is not running
// internal RX and TX bit clocks both from RX bit clock
// RX data input acting as digital input for burst mode
$73 $00 $70
// setup decoder
// decimate by 8
// decode adm input from RX Data
// adm estimator drives output
// decode vad driven by adm bits at bit rate
$D0 $00 $02
// adm encode feedback from comparator, nulling for improved idle - otherwise as decoder
$E0 $01 $02
// to enable offset nulling load small positive constant into encoder offset input reg
$E3 $00 $04
// adm mode BT CVSD algorithm
// syllabic tc=16ms
// step size dynamic range 1280/10
// companding rule = 4 of 4
// principal tc=0.5ms
// second order tc=N/A
// zero tc=N/A
// zero at bit_rate/2 disabled
$D1 $BD $A0
$E1 $BD $A0
// prime idle pattern into CBUS ADM source byte regs
$D8 $AA
$E8 $AA
// enable encoder and decoder with no IRQs
$81 $88
// Alternative settings for PCM format using second order ADM algorithm
// syllabic tc=16ms
// step size dynamic range 5120/10
// companding rule = 5 of 5
// principal tc=0.5ms
// second order tc=0.0625ms
// predictor zero tc=0.0234ms for encoder
// zero at bit_rate/2 enabled for decoder
//$D1 $AE $A1
//$E1 $AE $BA
// codec mode 2=linear PCM buffered (3=uLaw 4=Alaw)
//$70 $02
// decoder flow for input PCM plus transcode to ADM with offset null and output via VAD output.
//$D0 $57 $02
//$D3 $00 $04

```

7. Performance Specification

7.1 Electrical Performance

7.1.1 Absolute Maximum Ratings

Exceeding these maximum ratings can result in damage to the device.

| | Min. | Max. | Units |
|---------------------------------------------------|------|----------------|-------|
| Supply ($V_{DD} - V_{SS}$) | -0.3 | 7.0 | V |
| Voltage on any pin to V_{SS} | -0.3 | $V_{DD} + 0.3$ | V |
| Current into or out of V_{DD} and V_{SS} pins | -30 | +30 | mA |
| Current into or out of any other pin | -20 | +20 | mA |

| E3 and D3 Package | Min. | Max. | Units |
|------------------------------------------------------------------------|------|------|------------------------|
| E3 Total Allowable Power Dissipation at $T_{amb} = 25^{\circ}\text{C}$ | – | 300 | mW |
| Derating above 25°C | – | 5.0 | mW/ $^{\circ}\text{C}$ |
| D3 Total Allowable Power Dissipation at $T_{amb} = 25^{\circ}\text{C}$ | – | 800 | mW |
| Derating above 25°C | – | 13 | mW/ $^{\circ}\text{C}$ |
| Storage Temperature | -55 | +125 | $^{\circ}\text{C}$ |
| Operating Temperature | -40 | +85 | $^{\circ}\text{C}$ |

7.1.2 Operating Limits

Correct operation of the device outside these limits is not implied.

| | Notes | Min. | Max. | Units |
|------------------------------|-------|-------|--------|--------------------|
| Supply ($V_{DD} - V_{SS}$) | | 2.7 | 5.5 | V |
| Operating Temperature | | -40 | +85 | $^{\circ}\text{C}$ |
| External Clock Frequency | | 2.048 | 16.384 | MHz |
| Xtal Frequency | | 8.000 | 16.384 | MHz |

7.1.3 Operating Characteristics

The following conditions are assumed unless otherwise specified:

$V_{DD} = 2.7V$ to $5.5V$ at $T_{AMB} = -40$ to $+85^{\circ}C$, Audio Test Frequency = $820Hz$, Xtal/Clock $f_0 = 8.192MHz$, Data Rate = $32kbps$, Audio reference level (0 dBm_0) = $489mV_{RMS}$.

| | Notes | Min. | Typ. | Max. | Units |
|-------------------------------------------------------|-------|--------------|---------|--------------|------------|
| DC Parameters | | | | | |
| I_{DD} (powersaved) at $V_{DD} = 3.0V$ | 1 | – | 2.5 | 20 | μA |
| I_{DD} (powersaved) at $V_{DD} = 5.0V$ | 1 | – | 4.0 | 20 | μA |
| I_{DD} (XTAL only) at $V_{DD} = 3.0V$ | 1 | – | 0.70 | 1.3 | mA |
| I_{DD} (XTAL only) at $V_{DD} = 5.0V$ | 1 | – | 1.23 | 1.6 | mA |
| I_{DD} (low powermode) at $V_{DD} = 3.0V$ | 1 | – | 2.4 | 2.9 | mA |
| I_{DD} (low powermode) at $V_{DD} = 5.0V$ | 1 | – | 3.5 | 4.1 | mA |
| Input logic 1 | | $70\%V_{DD}$ | – | – | V |
| Input logic 0 | | – | – | $30\%V_{DD}$ | V |
| Output logic 1 | | $80\%V_{DD}$ | – | – | V |
| Output logic 0 | | – | – | $20\%V_{DD}$ | V |
| Logic I/O Pin Input Impedance | | 1.0 | – | – | $M\Omega$ |
| Logic Input Pins, Pull-up Resistor | | 300 | – | – | $k\Omega$ |
| Digital Output Impedance | | – | – | 4.0 | $k\Omega$ |
| Analog Input Impedance | | – | 200 | – | $k\Omega$ |
| AUDIO OUT Driver | | | | | |
| Small Signal Output Impedance at $V_{DD} = 2.7V$ | 7 | – | 70 | – | Ω |
| Small Signal Output Impedance at $V_{DD} = 5.5V$ | 7 | – | 50 | – | Ω |
| Output Current Limit at $V_{DD} = 2.7V$ | 7 | – | 1.1 | – | mA |
| Output Current Limit at $V_{DD} = 5.5V$ | 7 | – | 4.5 | – | mA |
| Three State Output Leakage | | – | ± 4 | – | μA |
| DAC Full Scale Reference Voltage | | – | 1.235 | – | V |
| Dynamic Values | | | | | |
| Encoder Analog Signal Input Sensitivity | | | | | |
| $V_{DD} = 3.0V$ | 2 | -37 | – | 4.0 | dB |
| $V_{DD} = 5.0V$ | 2 | -37 | – | 4.0 | dB |
| Encoder Input to Decoder Output Insertion Loss | | | | | |
| $V_{DD} = 3.0V$ | 2 | – | 0 | – | dB |
| $V_{DD} = 5.0V$ | 2 | – | 0 | – | dB |
| Encoder/Decoder (Full Codec) | | | | | |
| Passband Lowest Corner Frequency | 3 | – | 2900 | – | Hz |
| Passband Highest Corner Frequency | 3 | – | 1400 | – | Hz |
| Stopband Lowest Corner Frequency | 3 | – | 6.0 | – | kHz |
| Stopband Highest Corner Frequency | 3 | – | 24 | – | kHz |
| Stopband Attenuation | | – | 40 | – | dB |
| Passband Gain | | – | 0 | – | dB |
| Passband Ripple | 5 | -1.5 | – | 3.0 | dB |
| Output Noise (Input Short Circuit) | 4,6 | – | -61 | – | dBm_{Op} |
| Perfect Idle Channel Noise (Encode Forced) | 4,6 | – | -62 | – | dBm_{Op} |
| MIC Amplifier | | | | | |
| Open Loop Gain | | – | 6.0 | – | dB |
| Unity Gain Bandwidth | | – | 1.0 | – | MHz |
| Input Impedance | | 10 | – | – | $M\Omega$ |
| Output Impedance (open loop) | | – | 10 | – | $K\Omega$ |

| | | | | |
|------------|---|---|---|---|
| Distortion | – | 1 | 2 | % |
|------------|---|---|---|---|

- Notes:**
1. Not including any current drawn from the device by external circuits.
 2. Input and output signal levels are independent of supply voltage.
 3. Passband and stopband corner frequencies are programmable. Specified values are at nominal external clock or crystal frequencies of 4.096, 8.192, 12.288, or 16.384MHz with the master clock divider configured for a divide by 1, 2, 3, or 4 respectively. For other clock or crystal frequencies, passband and stopband corner frequencies must be scaled accordingly.
 4. dBmOp units imply the use of a psophometrically weighted filter that is commonly used in voice communication applications per ITU Recommendation G.223.
 5. From 400Hz to 3000Hz with a 3.7kHz bandwidth.
 6. At $V_{DD} = 2.7V$, data rate = 64kbps, 2.9kHz bandwidth, offsets compensated and 1st order integration only.
 7. AUDIO OUT driving a resistive load connected to a voltage source of $V_{DD}/2$.

7.1.3 (continued) C-BUS Timing Diagram

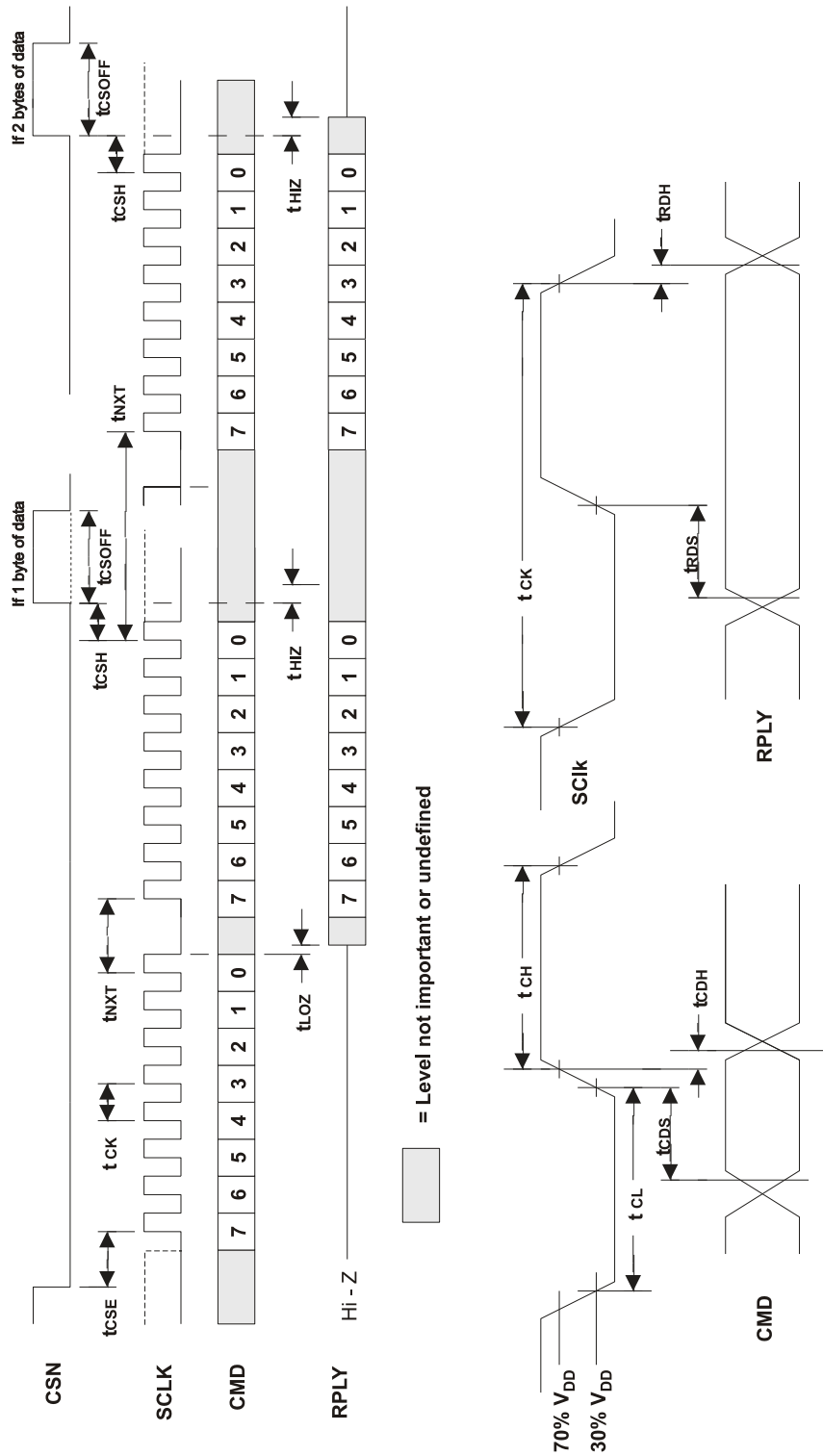

Figure 15 C-BUS Timing Diagram

| C-BUS Timing (see Figure 15) | | Notes | Min. | Typ. | Max. | Unit |
|-------------------------------------|------------------------------------------|--------------|-------------|-------------|-------------|-------------|
| t _{CSE} | CSN Enable to SClk high time | | 100 | | | ns |
| t _{CSH} | Last SClk high to CSN high time | | 100 | | | ns |
| t _{LOZ} | SClk low to ReplyData Output Enable Time | | 0.0 | | | ns |
| t _{HIZ} | CSN high to ReplyData high impedance | | | | 1.0 | µs |
| t _{CSOFF} | CSN high time between transactions | | 1.0 | | | µs |
| t _{NXT} | Inter-byte time | | 200 | | | ns |
| t _{CK} | SClk cycle time | | 200 | | | ns |
| t _{CH} | SClk high time | | 100 | | | ns |
| t _{CL} | SClk low time | | 100 | | | ns |
| t _{CDS} | Command Data setup time | | 75 | | | ns |
| t _{CDH} | Command Data hold time | | 25 | | | ns |
| t _{RDS} | Reply Data setup time | | 50 | | | ns |
| t _{RDH} | Reply Data hold time | | 0 | | | ns |

- Notes:**
1. Depending on the command, 1 or 2 bytes of COMMAND DATA are transmitted to the peripheral MSB (Bit 7) first, LSB (Bit 0) last. REPLY DATA is read from the peripheral MSB (Bit 7) first, LSB (Bit 0) last.
 2. Data is clocked into the peripheral on the rising SERIAL_CLOCK edge.
 3. Commands are acted upon at the end of each command (rising edge of CSN).
 4. To allow for differing µC serial interface formats C-BUS compatible ICs are able to work with SERIAL_CLOCK pulses starting and ending at either polarity.
 5. Maximum 30pF load on IRQN pin and each C-BUS interface line.

These timings are for the CMX649 and allow faster transfers than the original C-BUS specification.

For codec data interface timing specifications and diagrams please refer to section 6.2.

7.2 Packaging

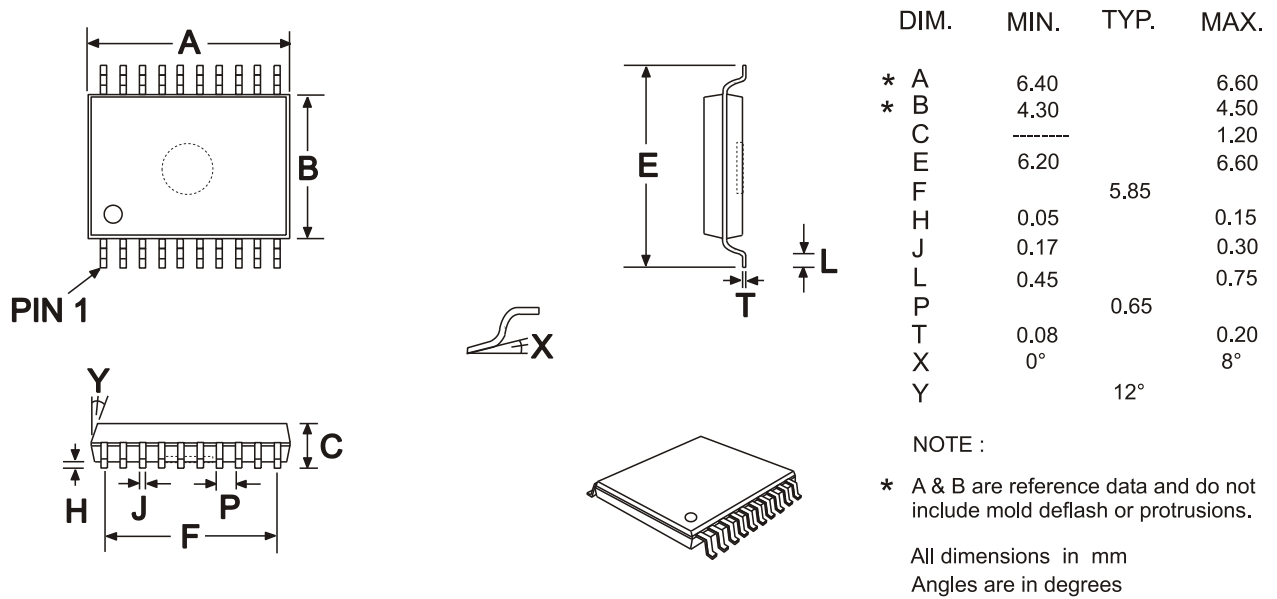

Figure 16 20-Lead TSSOP Mechanical Outline: *Order as part no. CMX649E3*

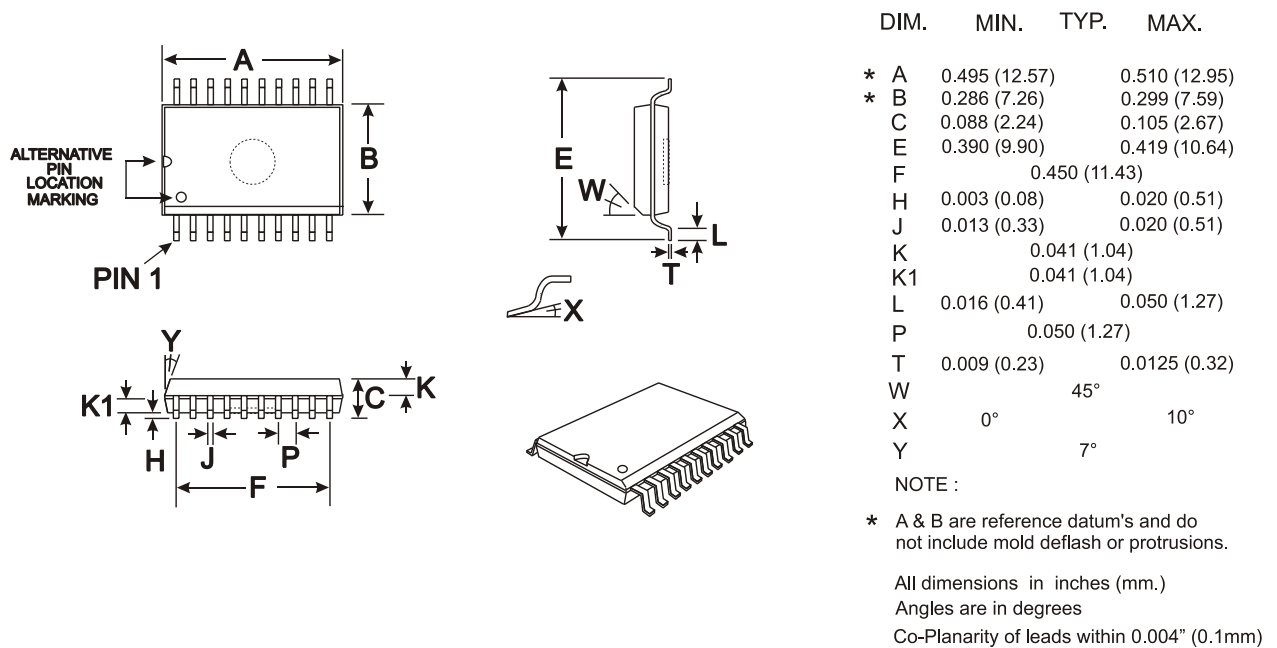

Figure 17 20-Lead SOIC Mechanical Outline: *Order as part no. CMX649D3*

Handling precautions: This product includes input protection, however, precautions should be taken to prevent device damage from electro-static discharge. CML does not assume any responsibility for the use of any circuitry described. No IPR or circuit patent licences are implied. CML reserves the right at any time without notice to change the said circuitry and this product specification. CML has a policy of testing every product shipped using calibrated test equipment to ensure compliance with this product specification. Specific testing of all circuit parameters is not necessarily performed.

| | | |
|--------------------------------------------------------------------------------------------------------------------------------------------------------------------------|-----------------------------------------------------------------------------------------------------------------------------------------------------------------------------------|---------------------------------------------------------------------------------------------------------------------------------------------------------------------------------------|
|  CML Microcircuits (UK) Ltd <small>COMMUNICATION SEMICONDUCTORS</small> |  CML Microcircuits (USA) Inc. <small>COMMUNICATION SEMICONDUCTORS</small> |  CML Microcircuits (Singapore) Pte Ltd <small>COMMUNICATION SEMICONDUCTORS</small> |
| Tel: +44 (0)1621 875500 Fax: +44 (0)1621 875600 Sales: sales@cmlmicro.com Tech Support: techsupport@cmlmicro.com | Tel: +1 336 744 5050 800 638 5577 Fax: +1 336 744 5054 Sales: us.sales@cmlmicro.com Tech Support: us.techsupport@cmlmicro.com | Tel: +65 62 888129 Fax: +65 62 888230 Sales: sg.sales@cmlmicro.com Tech Support: sg.techsupport@cmlmicro.com |
| - www.cmlmicro.com - | | |