

- 1997 PC Standard Compliant
- PCI Bus Power Management Interface Specification 1.1 Compliant
- ACPI 1.0 Compliant
- PCI Local Bus Specification Revision 2.1/2.2 Compliant
- PC 98/99 Compliant
- Compliant with the PCI Bus Interface Specification for PCI-to-CardBus Bridges
- Fully Compliant with the PCI Bus Power Management Specification for PCI to CardBus Bridges Specification
- Ultra Zoomed Video
- Zoomed Video Auto-Detect
- Advanced filtering on Card Detect Lines Provide 90 Microseconds of Noise Immunity.
- Programmable D3 Status Pin
- Internal Ring Oscillator
- 3.3-V Core Logic with Universal PCI Interfaces Compatible with 3.3-V and 5-V PCI Signaling Environments
- Mix-and-Match 5-V/3.3-V PC Card16 Cards and 3.3-V CardBus Cards
- Supports Two PC Card or CardBus Slots With Hot Insertion and Removal
- Uses Serial Interface to TI™ TPS2206 Dual Power Switch
- Supports 132 Mbyte/sec. Burst Transfers to Maximize Data Throughput on Both the PCI Bus and the CardBus Bus
- Supports Serialized IRQ with PCI Interrupts
- 8 Programmable Multifunction Pins
- Interrupt Modes Supported: Serial ISA/Serial PCI, Serial ISA/Parallel PCI, Parallel PCI Only.
- Serial EEPROM Interface for Loading Subsystem ID and Subsystem Vendor ID
- Supports Zoomed Video with Internal Buffering
- Dedicated Pin for PCI  $\overline{\text{CLKRUN}}$
- Four General-Purpose Event Registers
- Multifunction PCI Device with Separate Configuration Space for each Socket
- Five PCI Memory Windows and Two I/O Windows Available to each PC Card16 Socket
- Two I/O Windows and Two Memory Windows Available to each CardBus Socket
- ExCA™-Compatible Registers are Mapped in Memory or I/O Space
- Supports Distributed DMA and PC/PCI DMA
- Intel™ 82365SL-DF Register Compatible
- Supports 16-bit DMA on Both PC Card Sockets
- Supports Ring Indicate,  $\overline{\text{SUSPEND}}$ , and PCI  $\overline{\text{CLKRUN}}$
- Advanced Submicron, Low-Power CMOS Technology
- Provides VGA / Palette Memory and I/O, and Subtractive Decoding Options
- LED Activity Pins
- Supports PCI Bus Lock ( $\overline{\text{LOCK}}$ )
- Packaged in a 256-pin BGA or 257-pin Micro-Star BGA
- OHCI Link Function Designed to IEEE 1394 Open Host Controller Interface (OHCI) Specification
- Implements PCI Burst Transfers and Deep FIFOs to Tolerate Large Host Latency
- Supports Physical Write Posting of up to 3 Outstanding Transactions
- OHCI Link Function is IEEE 1394-1995 Compliant and Compatible with Proposal 1394a
- Supports Serial Bus Data Rates of 100, 200, and 400 Mbits/second
- Provides Bus-Hold Buffers on the PHY-Link I/F for Low-cost Single Capacitor Isolation



Please be aware that an important notice concerning availability, standard warranty, and use in critical applications of Texas Instruments semiconductor products and disclaimers thereto appears at the end of this data sheet.

Intel is a trademark of Intel Corporation.

PC Card is a trademark of Personal Computer Memory Card International Association (PCMCIA).

TI is a trademark of Texas Instruments Incorporated.



PRODUCTION DATA information is current as of publication date. Products conform to specifications per the terms of Texas Instruments standard warranty. Production processing does not necessarily include testing of all parameters.



POST OFFICE BOX 655303 • DALLAS, TEXAS 75265

Copyright © 1999, Texas Instruments Incorporated

# PCI4450 GFN/GJG PC Card and OHCI Controller

SCPS046 – JANUARY 1999

## Table of Contents

Description .....	3	GPIO Interface .....	182
Terminal Assignments .....	4	Serial EEPROM .....	183
Signal Names and Terminal Assignments .....	5	Absolute Maximum Ratings .....	185
PCI4450 System Block Diagram .....	9	Recommended Operating Conditions .....	186
Terminal Functions .....	10	Electrical Characteristics .....	187
I/O Characteristics .....	23	PCI Clock/Reset Timing Requirements .....	188
Clamping Voltages .....	23	PCI Timing Requirements .....	188
PCI Interface .....	24	Switching Characteristics for PHY-Link Interface .....	188
PC Card Applications Overview .....	28	Parameter Measurement Information .....	189
Programmable Interrupt Subsystem .....	35	PCI Bus Parameter Measurement Information .....	190
Power Management Overview .....	38	PC Card Cycle Timing .....	191
PC Card Controller Programming Model .....	43	Timing Requirements, (Memory Cycles) .....	192
PCI Configuration Registers (Functions 0 and 1) .....	44	Timing Requirements, (I/O Cycles) .....	197
ExCA Compatibility Registers (Functions 0 and 1) .....	82	Switching Characteristics (Miscellaneous) .....	193
CardBus Socket Registers (Functions 0 and 1) .....	106	PC Card Parameter Measurement Information .....	193
Distributed DMA (DDMA) Registers .....	114	Mechanical Data .....	195



POST OFFICE BOX 655303 • DALLAS, TEXAS 75265

## description

The Texas Instruments PCI4450 is an integrated dual-socket PC Card controller and IEEE 1394 Open HCI host controller. This high-performance integrated solution provides the latest in both PC Card and IEEE 1394 technology.

The PCI4450 is a three-function PCI device compliant with *PCI Local Bus Specification 2.2*. Functions 0 and 1 provide the independent PC Card socket controllers compliant with the 1997 PC Card Standard. The PCI4450 provides features that make it the best choice for bridging between the PCI bus and PC Cards, and supports any combination of 16-bit and CardBus PC Cards in the two sockets, powered at 5 V or 3.3 V, as required.

All card signals are internally buffered to allow hot insertion and removal without external buffering. The PCI4450 is register compatible with the Intel 82365SL–DF ExCA controller. The PCI4450 internal data path logic allows the host to access 8-, 16-, and 32-bit cards using full 32-bit PCI cycles for maximum performance. Independent buffering and a pipeline architecture provide an unsurpassed performance level with sustained bursting. The PCI4450 can be programmed to accept posted writes to improve bus utilization.

Function 2 of the PCI4450 is compatible with IEEE1394A and the latest 1394 open host controller interface (OHCI) specifications. The chip provides the IEEE1394 link function and is compatible with data rates of 100, 200, and 400 Mbits per second. Deep FIFOs are provided to buffer 1394 data and accommodate large host bus latencies. The PCI4450 provides physical write posting and a highly tuned physical data path for SBP-2 performance. Multiple cache line burst transfers, advanced internal arbitration, and bus holding buffers on the PHY/Link interface are other features that make the PCI4450 the best-in-class 1394 Open HCI solution.

The PCI4450 provides an internally buffered zoomed video (ZV) path. This reduces the design effort of PC board manufacturers to add a ZV-compatible solution and guarantees compliance with the CardBus loading specifications.

Various implementation specific functions and general-purpose inputs and outputs are provided through eight multifunction terminals. These terminals present a system with options in PC/PCI DMA, PCI  $\overline{\text{LOCK}}$  and parallel interrupts, PC Card activity indicator LEDs, and other platform specific signals. ACPI-complaint general-purpose events may be programmed and controlled through the multifunction terminals, and an ACPI-compliant programming interface is included for the general-purpose inputs and outputs.

The PCI4450 is compliant with the latest *PCI Bus Power Management Specification*, and provides several low-power modes which enable the host power system to further reduce power consumption. The *PC Card (CardBus) Controller* and *IEEE 1394 Host Controller Device Class Specifications* required for Microsoft OnNow™ Power Management are supported. Furthermore, an advanced complementary metal-oxide semiconductor (CMOS) process achieves low system power consumption.

Unused PCI4450 inputs must be pulled to a valid logic level using a 43 k $\Omega$  resistor.

## use of symbols in this document

Throughout this data sheet the overbar symbol denotes an active-low signal. For example:  $\overline{\text{FRAME}}$  denotes that this is an active-low signal.

# PCI4450 GFN/GJG PC Card and OHCI Controller

SCPS046 – JANUARY 1999

## terminal assignments

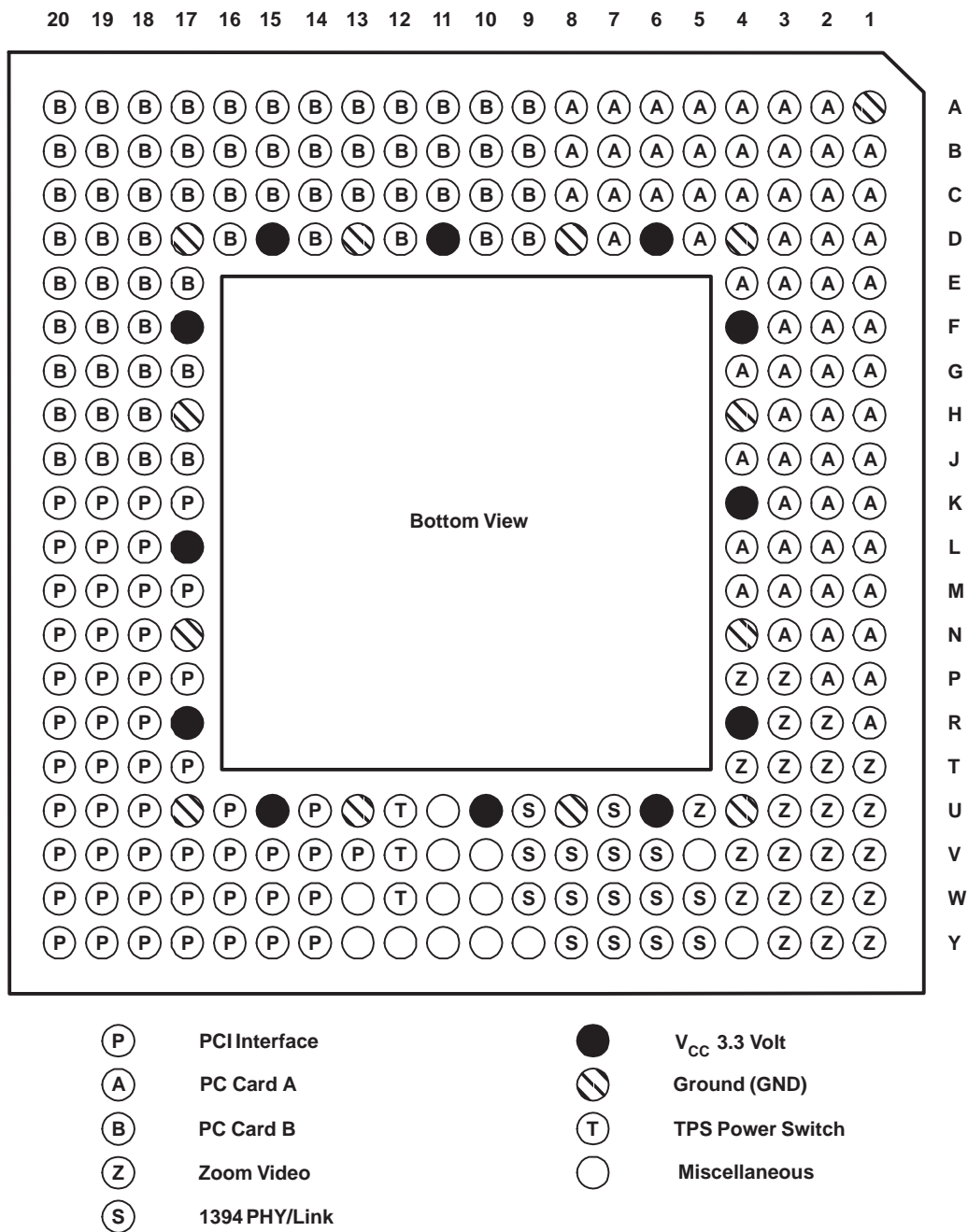

Figure 1. PCI4450 Pin Diagram

signal names and terminal assignments

Signal names and their terminal assignments are shown in Tables 1 and 2 and are sorted alphanumerically by the assigned terminal.

Table 1. GFN Terminals Sorted Alphanumerically for CardBus // 16-bit Signals and OHCI

GFN	SIGNAL NAME	GFN	SIGNAL NAME	GFN	SIGNAL NAME
A1	GND	C9	B_RSVD//B_D2	G1	A_CVS2//A_VS2
A2	A_CAD16//A_A17	C10	B_CAD27//B_D0	G2	A_CAD19//A_A25
A3	A_CAD11//A_OE	C11	B_CAUDIO//B_BVD2(SPKR)	G3	A_CAD18//A_A7
A4	A_CC/BE0//A_CE1	C12	B_CAD26//B_A0	G4	A_CFRAME//A_A23
A5	A_RSVD//A_D14	C13	B_CC/BE3//B_REG	G17	B_CAD10//B_CE2
A6	A_CAD3//A_D5	C14	B_CAD22//B_A4	G18	B_CAD8//B_D15
A7	A_CAD1//A_D4	C15	B_CVS2//B_VS2	G19	B_RSVD//B_D14
A8	A_CCD1//A_CD1	C16	B_CAD17//B_A24	G20	B_CAD5//B_D6
A9	B_CAD29//B_D1	C17	B_CTRDY//B_A22	H1	A_CAD21//A_A5
A10	B_CCLKRUN//B_WP(IOIS16)	C18	B_CBLOCK//B_A19	H2	A_CRST//A_RESET
A11	B_CSTSCHG//B_BVD1(STSCHGRI)	C19	B_RSVD//B_A18	H3	A_CAD20//A_A6
A12	B_CINT//B_READY(IREQ)	C20	B_CAD14//B_A9	H4	GND
A13	B_CAD24//B_A2	D1	A_CDEVSEL//A_A21	H17	GND
A14	B_CAD23//B_A3	D2	A_CBLOCK//A_A19	H18	B_CAD6//B_D13
A15	B_CAD21//B_A5	D3	A_CPERR//A_A14	H19	B_CAD3//B_D5
A16	B_CAD19//B_A25	D4	GND	H20	B_CAD4//B_D12
A17	B_CC/BE2//B_A12	D5	A_CAD13//A_IORD	J1	A_CC/BE3//A_REG
A18	B_CFRAME//B_A23	D6	VCC	J2	A_CAD23//A_A3
A19	B_CGNT//B_WE	D7	A_CAD7//A_D7	J3	A_CREQ//A_INPACK
A20	B_CSTOP//B_A20	D8	GND	J4	A_CAD22//A_A4
B1	A_RSVD//A_A18	D9	B_CAD31//B_D10	J17	B_CAD1//B_D4
B2	A_CAD14//A_A9	D10	B_CAD28//B_D8	J18	B_CAD2//B_D11
B3	A_CAD15//A_IOWR	D11	VCC	J19	B_CAD0//B_D3
B4	A_CAD10//A_CE2	D12	B_CAD25//B_A1	J20	B_CCD1//B_CD1
B5	VCCA	D13	GND	K1	A_CAD26//A_A0
B6	A_CAD5//A_D6	D14	B_CAD20//B_A6	K2	A_CAD24//A_A2
B7	A_CAD4//A_D12	D15	VCC	K3	A_CAD25//A_A1
B8	A_CAD0//A_D3	D16	B_CIRDY//B_A15	K4	VCC
B9	B_CAD30//B_D9	D17	GND	K17	PCLK
B10	B_CCD2//B_CD2	D18	B_CC/BE1//B_A8	K18	CLKRUN
B11	B_CSERR//B_WAIT	D19	B_CAD15//B_IOWR	K19	PRST
B12	B_CVS1//B_VS1	D20	B_CAD13//B_IORD	K20	GNT
B13	VCCB	E1	A_CIRDY//A_A15	L1	A_CVS1//A_VS1
B14	B_CREQ//B_INPACK	E2	A_CTRDY//A_A22	L2	A_CINT//A_READY(IREQ)
B15	B_CRST//B_RESET	E3	A_CCLK//A_A16	L3	A_CSERR//A_WAIT
B16	B_CAD18//B_A7	E4	A_CSTOP//A_A20	L4	VCCA
B17	B_CCLK//B_A16	E17	B_CAD16//B_A17	L17	VCC
B18	B_CDEVSEL//B_A21	E18	B_CAD12//B_A11	L18	AD31
B19	B_CPERR//B_A14	E19	VCCB	L19	AD30
B20	B_CPAR//B_A13	E20	B_CAD9//B_A10	L20	REQ
C1	A_CGNT//A_WE	F1	A_CAD17//A_A24	M1	A_CAUDIO//A_BVD2(SPKR)
C2	A_CPAR//A_A13	F2	A_CC/BE2//A_A12	M2	A_CSTSCHG//A_BVD1(STSCHGRI)
C3	A_CC/BE1//A_A8	F3	VCCA	M3	A_CCLKRUN//A_WP(IOIS16)
C4	A_CAD12//A_A11	F4	VCC	M4	A_CCD2//A_CD2
C5	A_CAD9//A_A10	F17	VCC	M17	AD26
C6	A_CAD8//A_D15	F18	B_CAD11//B_OE	M18	AD27
C7	A_CAD6//A_D13	F19	B_CC/BE0//B_CE1	M19	AD28
C8	A_CAD2//A_D11	F20	B_CAD7//B_D7	M20	AD29

# PCI4450 GFN/GJG PC Card and OHCI Controller

SCPS046 – JANUARY 1999

## signal names and terminal assignments (continued)

**Table 1. GFN Terminals Sorted Alphanumerically for CardBus // 16-bit Signals and OHCI (Continued)**

GFN	SIGNAL NAME	GFN	SIGNAL NAME	GFN	SIGNAL NAME
N1	A_CAD27//A_D0	U7	PHY_CTL0	W4	ZV_MCLK
N2	A_CAD28//A_D8	U8	GND	W5	LPS
N3	A_CAD29//A_D1	U9	PHY_DATA6	W6	PHY_CTL1
N4	GND	U10	VCC	W7	PHY_DATA1
N17	GND	U11	SUSPEND	W8	PHY_DATA4
N18	C/BE3	U12	CLOCK	W9	MFUNC4
N19	AD24	U13	GND	W10	SCL
N20	AD25	U14	AD6	W11	MFUNC0
P1	A_CAD30//A_D9	U15	VCC	W12	LATCH
P2	A_RSVD//A_D2	U16	AD12	W13	IRQSER
P3	ZV_HREF	U17	GND	W14	AD2
P4	ZV_Y1	U18	TRDY	W15	AD4
P17	AD20	U19	DEVSEL	W16	C/BE0
P18	AD23	U20	C/BE2	W17	AD10
P19	VCCP	V1	ZV_Y7	W18	AD14
P20	IDSEL/MFUNC7	V2	ZV_UV1	W19	PAR
R1	A_CAD31//A_D10	V3	ZV_UV3	W20	PERR
R2	ZV_VSYNC	V4	ZV_LRCLK	Y1	ZV_UV5
R3	ZV_Y2	V5	MFUNC5	Y2	ZV_UV7
R4	VCC	V6	PHY_CLK	Y3	ZV_PCLK
R17	VCC	V7	PHY_DATA0	Y4	MFUNC6
R18	AD19	V8	PHY_DATA3	Y5	PHY_LREQ
R19	AD21	V9	PHY_DATA7	Y6	LINKON
R20	AD22	V10	MFUNC3	Y7	PHY_DATA2
T1	ZV_Y0	V11	SPKROUT	Y8	PHY_DATA5
T2	ZV_Y3	V12	DATA	Y9	SDA
T3	ZV_Y5	V13	AD0	Y10	MFUNC2
T4	ZV_UV0	V14	VCCP	Y11	MFUNC1
T17	IRDY	V15	AD7	Y12	G_RST
T18	AD16	V16	AD9	Y13	RI_OUT
T19	AD17	V17	AD13	Y14	AD1
T20	AD18	V18	C/BE1	Y15	AD3
U1	ZV_Y4	V19	STOP	Y16	AD5
U2	ZV_Y6	V20	FRAME	Y17	AD8
U3	ZV_UV2	W1	ZV_UV4	Y18	AD11
U4	GND	W2	ZV_UV6	Y19	AD15
U5	ZV_SDATA	W3	ZV_SCLK	Y20	SERR
U6	VCC				



signal names and terminal assignments (continued)

Table 2. GJG Terminals Sorted Alphanumerically for CardBus // 16-bit Signals and OHCI

NO.	SIGNAL NAME	NO.	SIGNAL NAME	NO.	SIGNAL NAME
A2	A_CC/BE1//A_A8	D12	B_CAD24//B_A2	G16	B_CC/BE0//B_CE1
A3	GND	D13	B_CAD23//B_A3	G18	B_CAD8//B_D15
A4	A_CAD12//A_A11	D14	VCC	G19	GND
A5	A_CAD10//A_CE2	D15	B_CFRAME//B_A23	H1	A_CAD20//A_A6
A6	A_CAD8//A_D15	D16	B_CBLOCK//B_A19	H2	A_CRST//A_RESET
A7	A_CAD3//A_D5	D18	B_RSVD//B_A18	H4	A_CAD21//A_A5
A8	A_CAD0//A_D3	D19	B_CC/BE1//B_A8	H5	A_CAD22//A_A4
A9	B_CAD29//B_D1	E1	VCC	H6	A_CVS2//A_VS2
A10	B_CSTSCHG//B_BVD1(STSCHGRI)	E2	A_CCLK//A_A16	H14	B_CAD4//B_D12
A11	VCC	E4	A_CGNT//A_WE	H15	B_RSVD//B_D14
A12	B_CC/BE3//B_REG	E5	A_CDEVSEL//A_A21	H16	B_CAD5//B_D6
A13	B_CREQ//B_INPACK	E6	VCC	H18	B_CAD6//B_D13
A14	B_CVS2//B_VS2	E7	A_RSVD//A_D14	H19	B_CAD3//B_D5
A15	B_CAD17//B_A24	E8	A_CAD1//A_D4	J1	A_CAD23//A_A3
A16	GND	E9	B_CAD31//B_D10	J2	A_CC/BE3//A_REG
A17	B_CCLK//B_A16	E10	B_CAD27//B_D0	J4	A_CREQ//A_INPACK
A18	B_CDEVSEL//B_A21	E11	B_CINT//B_READY(IREQ)	J5	A_CAD24//A_A2
B1	A_CPAR//A_A13	E12	B_CAD25//B_A1	J6	A_CAD25//A_A1
B2	A_RSVD//A_A18	E13	B_CAD21//B_A5	J14	VCC
B3	A_CAD16//A_A17	E14	B_CAD19//B_A25	J15	B_CAD1//B_D4
B4	A_CAD15//A_IOWR	E15	B_CC/BE2//B_A12	J16	B_CAD2//B_D11
B5	A_CAD11//A_OE	E16	B_CAD16//B_A17	J18	B_CAD0//B_D3
B6	VCCA	E18	B_CAD14//B_A9	J19	B_CCD1//B_CD1
B7	A_CAD6//A_D13	E19	VCC	K1	A_CVS1//A_VS1
B8	A_CAD2//A_D11	F1	VCCA	K2	A_CINT//A_READY(IREQ)
B9	B_CAD30//B_D9	F2	A_CFRAME//A_A23	K4	A_CSERR//A_WAIT
B10	B_CCLKRUN//B_WP(IOIS16)	F4	A_CIRDY//A_A15	K5	VCCA
B11	B_CVS1//B_VS1	F5	A_CTRDY//A_A22	K6	A_CAD26//A_A0
B12	VCCB	F6	A_CAD9//A_A10	K14	GNT
B13	B_CAD22//B_A4	F7	A_CAD7//A_D7	K15	PCLK
B14	B_CAD20//B_A6	F8	A_CCD1//A_CD1	K18	CLKRUN
B15	B_CAD18//B_A7	F9	B_CAD28//B_D8	K19	PRST
B16	B_CIRDY//B_A15	F10	B_CAUDIO//B_BVD2(SPKR)	L1	A_CSTSCHG//A_BVD1(STSCHGRI)
B17	B_CTRDY//B_A22	F11	B_CSERR//B_WAIT	L2	A_CCLKRUN//A_WP(IOIS16)
B18	B_CGNT//B_WE	F12	GND	L4	A_CCD2//A_CD2
B19	B_CSTOP//B_A20	F13	B_CRST//B_RESET	L5	A_CAD27//A_D0
C1	GND	F14	B_CAD15//B_IOWR	L6	A_CAUDIO//A_BVD2(SPKR)
C2	A_CBLOCK//A_A19	F15	B_CAD12//B_A11	L14	REQ
C18	B_CPERR//B_A14	F16	B_CAD13//B_IORD	L15	AD31
C19	B_CPAR//B_A13	F18	VCCB	L16	AD28
D1	A_CPERR//A_A14	F19	B_CAD11//B_OE	L18	AD30
D2	A_CSTOP//A_A20	G1	GND	L19	AD29
D4	A_CAD14//A_A9	G2	A_CAD18//A_A7	M1	A_CAD29//A_D1
D5	A_CAD13//A_IORD	G4	A_CAD19//A_A25	M2	GND
D6	A_CC/BE0//A_CE1	G5	A_CAD17//A_A24	M4	A_CAD30//A_D9
D7	A_CAD5//A_D6	G6	A_CC/BE2//A_A12	M5	A_RSVD//A_D2
D8	GND	G7	A_CAD4//A_D12	M6	A_CAD28//A_D8
D9	B_RSVD//B_D2	G13	B_CAD7//B_D7	M14	C/BE3
D10	B_CCD2//B_CD2	G14	B_CAD10//B_CE2	M15	AD27
D11	B_CAD26//B_A0	G15	B_CAD9//B_A10	M16	AD26

# PCI4450 GFN/GJG PC Card and OHCI Controller

SCPS046 – JANUARY 1999

## signal names and terminal assignments (continued)

**Table 2. GJG Terminals Sorted Alphanumerically for CardBus // 16-bit Signals and OHCI (Continued)**

NO.	SIGNAL NAME	NO.	SIGNAL NAME	NO.	SIGNAL NAME
M18	AD25	R6	PHY_LREQ	V2	ZV_SCLK
M19	AD24	R7	PHY_DATA0	V3	ZV_LRCLK
N1	ZV_HREF	R8	PHY_DATA7	V4	ZV_PCLK
N2	ZV_VSYNC	R9	MFUNC3	V5	LPS
N4	ZV_Y0	R10	SUSPEND	V6	PHY_CTL1
N5	ZV_Y1	R11	RI_OUT	V7	PHY_DATA1
N6	ZV_Y2	R12	AD2	V8	PHY_DATA5
N7	A_CAD31//A_D10	R13	AD5	V9	SCL
N13	AD3	R14	AD8	V10	VCC
N14	AD22	R15	AD16	V11	DATA
N15	AD23	R16	C/BE2	V12	AD0
N16	GND	R18	AD18	V13	VCC
N18	VCCP	R19	AD17	V14	GND
N19	IDSEL/MFUNC7	T1	ZV_UV1	V15	AD11
P1	VCC	T2	ZV_UV4	V16	AD14
P2	ZV_Y3	T4	GND	V17	PAR
P4	ZV_Y4	T5	VCC	V18	PERR
P5	ZV_Y5	T6	PHY_CLK	V19	STOP
P6	ZV_Y6	T7	GND	W2	ZV_UV7
P7	LINKON	T8	PHY_DATA6	W3	ZV_MCLK
P8	PHY_DATA3	T9	MFUNC4	W4	ZV_SDATA
P9	MFUNC2	T10	SPKROUT	W5	MFUNC5
P10	MFUNC1	T11	CLOCK	W6	PHY_CTL0
P11	G_RST	T12	AD1	W7	PHY_DATA2
P12	IRQSER	T13	AD4	W8	PHY_DATA4
P13	AD6	T14	C/BE0	W9	SDA
P14	AD9	T15	AD12	W10	MFUNC0
P15	VCC	T16	C/BE1	W11	LATCH
P16	AD19	T18	FRAME	W12	GND
P18	AD21	T19	IRDY	W13	VCCP
P19	AD20	U1	ZV_UV3	W14	AD7
R1	ZV_Y7	U2	ZV_UV6	W15	AD10
R2	ZV_UV0	U18	TRDY	W16	AD13
R4	ZV_UV2	U19	DEVSEL	W17	AD15
R5	MFUNC6	V1	ZV_UV5	W18	SERR





**PCI4450 System Block Diagram**

Figure 2 shows a simplified system implementation example using the PCI4450. The PCI interface includes all address/data and control signals for PCI protocol. Highlighted in this diagram is the functionality supported by the PCI4450. The PCI4450 supports PC/PCI DMA, PCI Way DMA (distributed DMA),  $\overline{\text{PME}}$  wake-up from  $\text{D3}_{\text{cold}}$  through  $\text{D0}$ , 4 interrupt modes, an integrated zoomed video port, and 12 multifunction pins (8 MFUNC, and 4 GPIO pins) that can be programmed for a wide variety of functions.

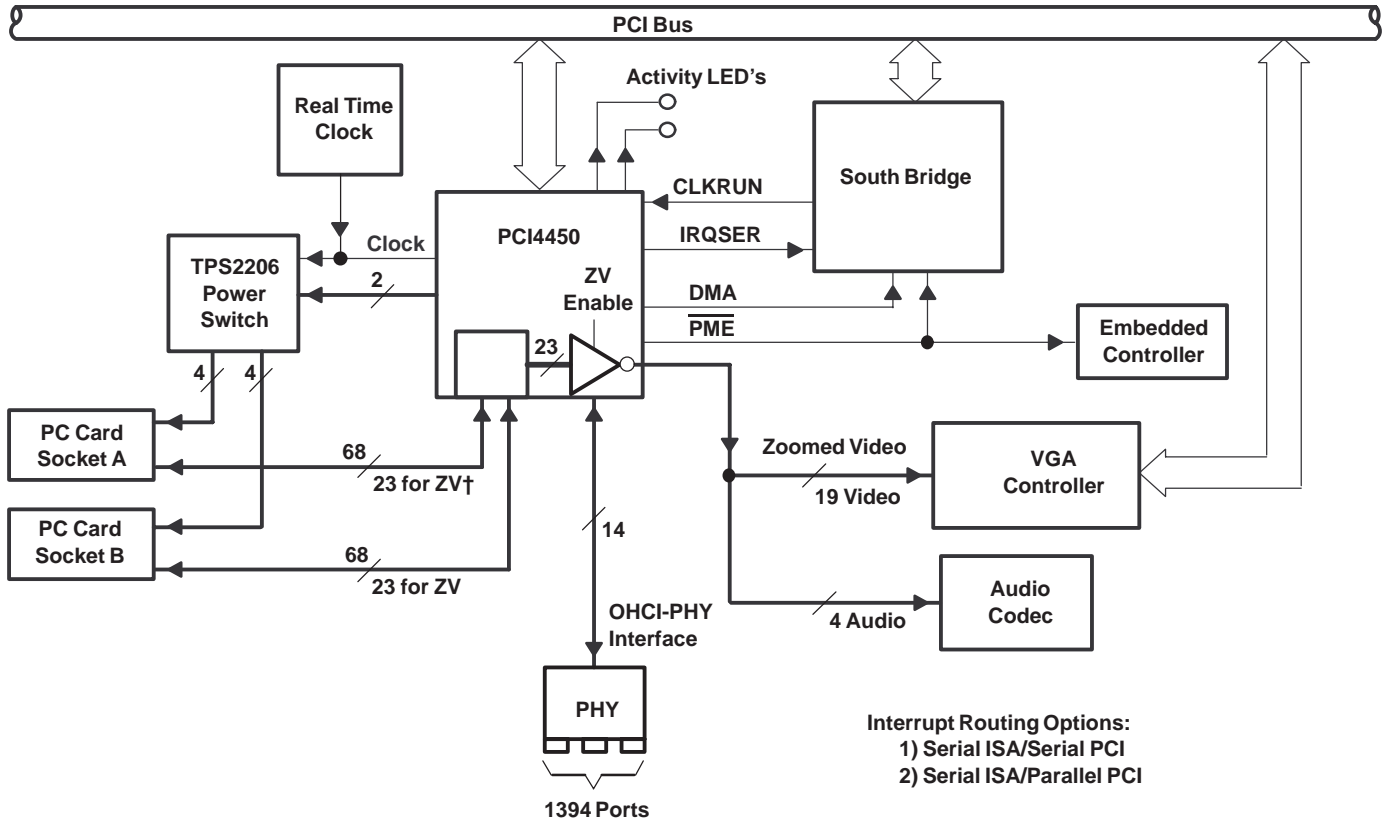

† The PC Card interface is 68 pins for CardBus and 16-bit PC Cards. In zoomed-video mode 23 pins are used for routing the zoomed video signals to the VGA controller.

**Figure 2. PCI4450 System Block Diagram**

# PCI4450 GFN/GJG PC Card and OHCI Controller

SCPS046 – JANUARY 1999

## terminal functions

This section describes the PCI4450 terminal functions. The terminals are grouped in tables by functionality such as PCI system function, power supply function, etc., for quick reference. The terminal numbers are also listed for convenient reference.

**Table 3. Power Supply**

NAME	TERMINAL		FUNCTION
	GFN NO.	GJG NO.	
GND	A1, D4, D8, D13, D17, H4, H17, N4, N17, U4, U8, U13, U17	A3, A16, C1, D8, F12, G1, G19, M2, N16, T4, T7, V14, W12	Device ground terminals
V <sub>CC</sub>	D6, D11, D15, F4, F17, K4, L17, R4, R17, U6, U10, U15	A11, D14, E1, E6, E19, J14, P1, P15, T5, V10, V13	Power supply terminal for core logic (3.3 Vdc)
V <sub>CCA</sub>	B5, F3, L4	B6, F1, K5	Clamp voltage for PC Card A interface. Indicates Card A signaling environment.
V <sub>CCB</sub>	B13, E19	B12, F18	Clamp voltage for PC Card B interface. Indicates Card B signaling environment.
V <sub>CCP</sub>	P19, V14	N18, W13	Clamp voltage for PCI signaling (3.3 Vdc or 5 Vdc)

**Table 4. PC Card Power Switch**

NAME	TERMINAL		I/O TYPE	FUNCTION
	GFN NO.	GJG NO.		
CLOCK	U12	T11	I/O	3-line power switch clock. Information on the DATA line is sampled at the rising edge of CLOCK. This terminal defaults as an input which means an external clock source must be used. If the internal ring oscillator is used, then an external CLOCK source is not required. The internal oscillator may be enabled by setting bit 27 of the system control register (PCI offset 80h) to a 1b. A 43 kΩ pulldown resistor should be tied to this terminal.
DATA	V12	V11	O	3-line power switch data. DATA is used to serially communicate socket power-control information to the power switch.
LATCH	W12	W11	O	3-line power switch latch. LATCH is asserted by the PCI4450 to indicate to the PC Card power switch that the data on the DATA line is valid.



terminal functions (continued)

Table 5. PCI System

NAME	TERMINAL		I/O TYPE	FUNCTION
	GFN NO.	GJG NO.		
$\overline{\text{CLKRUN}}$	K18	K18	I/O	PCI clock run. $\overline{\text{CLKRUN}}$ is used by the central resource to request permission to stop the PCI clock or to slow it down, and the PCI4450 responds accordingly. If $\overline{\text{CLKRUN}}$ is not implemented, then this pin should be tied low. $\overline{\text{CLKRUN}}$ is enabled by default by bit 1 (KEEPCLK) in the system control register.
PCLK	K17	K15	I	PCI bus clock. PCLK provides timing for all transactions on the PCI bus. All PCI signals are sampled at the rising edge of PCLK.
$\overline{\text{PRST}}$	K19	K19	I	PCI reset. When the PCI bus reset is asserted, $\overline{\text{PRST}}$ causes the PCI4450 to place all output buffers in a high-impedance state and reset all internal registers. When $\overline{\text{PRST}}$ is asserted, the device is completely nonfunctional. After $\overline{\text{PRST}}$ is deasserted, the PCI4450 is in its default state. When the SUSPEND mode is enabled, the device is protected from the $\overline{\text{PRST}}$ and the internal registers are preserved. All outputs are placed in a high-impedance state, but the contents of the registers are preserved.
$\overline{\text{G\_RST}}$	Y12	P11	I	Global reset. When the global reset is asserted, the $\overline{\text{G\_RST}}$ signal causes the PCI4450 to place all output buffers in a high-impedance state and reset all internal registers. When $\overline{\text{G\_RST}}$ is asserted, the device is completely in its default state. For systems that require wake-up from D3, $\overline{\text{G\_RST}}$ will normally be asserted only during initial boot. $\overline{\text{PRST}}$ should be asserted following initial boot so that PME context is retained when transitioning from D3 to D0. For systems that do not require wake-up from D3, $\overline{\text{G\_RST}}$ should be tied to $\overline{\text{PRST}}$ .

# PCI4450 GFN/GJG PC Card and OHCI Controller

SCPS046 – JANUARY 1999

## terminal functions (continued)

Table 6. PCI Address and Data

NAME	TERMINAL		I/O TYPE	FUNCTION
	GFN NO.	GJG NO.		
AD31	L18	L15	I/O	PCI address/data bus. These signals make up the multiplexed PCI address and data bus on the primary interface. During the address phase of a primary bus PCI cycle, AD31–AD0 contain a 32-bit address or other destination information. During the data phase, AD31–AD0 contain data.
AD30	L19	L18		
AD29	M20	L19		
AD28	M19	L16		
AD27	M18	M15		
AD26	M17	M16		
AD25	N20	M18		
AD24	N19	M19		
AD23	P18	N15		
AD22	R20	N14		
AD21	R19	P18		
AD20	P17	P19		
AD19	R18	P16		
AD18	T20	R18		
AD17	T19	R19		
AD16	T18	R15		
AD15	Y19	W17		
AD14	W18	V16		
AD13	V17	W16		
AD12	U16	T15		
AD11	Y18	V15		
AD10	W17	W15		
AD9	V16	P14		
AD8	Y17	R14		
AD7	V15	W14		
AD6	U14	P13		
AD5	Y16	R13		
AD4	W15	T13		
AD3	Y15	N13		
AD2	W14	R12		
AD1	Y14	T12		
AD0	V13	V12		
$\overline{C/BE3}$	N18	M14	I/O	PCI bus commands and byte enables. These signals are multiplexed on the same PCI terminals. During the address phase of a primary bus PCI cycle, $\overline{C/BE3}$ – $\overline{C/BE0}$ define the bus command. During the data phase, this 4-bit bus is used as byte enables. The byte enables determine which byte paths of the full 32-bit data bus carry meaningful data. $\overline{C/BE0}$ applies to byte 0 (AD7–AD0), $\overline{C/BE1}$ applies to byte 1 (AD15–AD8), $\overline{C/BE2}$ applies to byte 2 (AD23–AD16), and $\overline{C/BE3}$ applies to byte 3 (AD31–AD24).
$\overline{C/BE2}$	U20	R16		
$\overline{C/BE1}$	V18	T16		
$\overline{C/BE0}$	W16	T14		
PAR	W19	V17	I/O	PCI bus parity. In all PCI bus read and write cycles, the PCI4450 calculates even parity across the AD31–AD0 and $\overline{C/BE3}$ – $\overline{C/BE0}$ buses. As an initiator during PCI cycles, the PCI4450 outputs this parity indicator with a one-PCLK delay. As a target during PCI cycles, the calculated parity is compared to the initiator's parity indicator. A compare error results in the assertion of a parity error (PERR).



terminal functions (continued)

Table 7. PCI Interface Control

TERMINAL			I/O TYPE	FUNCTION
NAME	GFN NO.	GJG NO.		
$\overline{\text{DEVSEL}}$	U19	U19	I/O	PCI device select. The PCI4450 asserts $\overline{\text{DEVSEL}}$ to claim a PCI cycle as the target device. As a PCI initiator on the bus, the PCI4450 monitors $\overline{\text{DEVSEL}}$ until a target responds. If no target responds before timeout occurs, then the PCI4450 terminates the cycle with an initiator abort.
$\overline{\text{FRAME}}$	V20	T18	I/O	PCI cycle frame. $\overline{\text{FRAME}}$ is driven by the initiator of a bus cycle. $\overline{\text{FRAME}}$ is asserted to indicate that a bus transaction is beginning, and data transfers continue while this signal is asserted. When $\overline{\text{FRAME}}$ is deasserted, the PCI bus transaction is in the final data phase.
$\overline{\text{GNT}}$	K20	K14	I	PCI bus grant. $\overline{\text{GNT}}$ is driven by the PCI bus arbiter to grant the PCI4450 access to the PCI bus after the current data transaction has completed. $\overline{\text{GNT}}$ may or may not follow a PCI bus request, depending on the PCI bus parking algorithm.
$\overline{\text{LOCK}}$ (MFUNC7)	P20	N19	I/O	PCI bus lock. MFUNC7/ $\overline{\text{LOCK}}$ can be configured as PCI $\overline{\text{LOCK}}$ and used to gain exclusive access downstream. Since this functionality is not typically used, other functions may be accessed through this terminal. MFUNC7/ $\overline{\text{LOCK}}$ defaults to and can be configured through the multifunction routing status register.
IDSEL/MFUNC7	P20	N19	I	Initialization device select. IDSEL selects the PCI4450 during configuration space accesses. IDSEL can be connected to one of the upper 24 PCI address lines on the PCI bus. If the LATCH terminal (W12/W11) has an external pulldown resistor, then this terminal is configurable as MFUNC7 and IDSEL defaults to the AD23 terminal.
$\overline{\text{IRDY}}$	T17	T19	I/O	PCI initiator ready. $\overline{\text{IRDY}}$ indicates the PCI bus initiator's ability to complete the current data phase of the transaction. A data phase is completed on a rising edge of PCLK where both $\overline{\text{IRDY}}$ and $\overline{\text{TRDY}}$ are asserted. Until $\overline{\text{IRDY}}$ and $\overline{\text{TRDY}}$ are both sampled asserted, wait states are inserted.
$\overline{\text{PERR}}$	W20	V18	I/O	PCI parity error indicator. $\overline{\text{PERR}}$ is driven by a PCI device to indicate that calculated parity does not match PAR when PERR is enabled through bit 6 of the command register.
$\overline{\text{REQ}}$	L20	L14	O	PCI bus request. $\overline{\text{REQ}}$ is asserted by the PCI4450 to request access to the PCI bus as an initiator.
$\overline{\text{SERR}}$	Y20	W18	O	PCI system error. $\overline{\text{SERR}}$ is an output that is pulsed from the PCI4450 when enabled through the command register, indicating a system error has occurred. The PCI4450 need not be the target of the PCI cycle to assert this signal. When $\overline{\text{SERR}}$ is enabled in the bridge control register, this signal also pulses, indicating that an address parity error has occurred on a CardBus interface.
$\overline{\text{STOP}}$	V19	V19	I/O	PCI cycle stop signal. $\overline{\text{STOP}}$ is driven by a PCI target to request the initiator to stop the current PCI bus transaction. $\overline{\text{STOP}}$ is used for target disconnects and is commonly asserted by target devices that do not support burst data transfers.
$\overline{\text{TRDY}}$	U18	U18	I/O	PCI target ready. $\overline{\text{TRDY}}$ indicates the primary bus target's ability to complete the current data phase of the transaction. A data phase is completed on a rising edge of PCLK when both $\overline{\text{IRDY}}$ and $\overline{\text{TRDY}}$ are asserted. Until both $\overline{\text{IRDY}}$ and $\overline{\text{TRDY}}$ are asserted, wait states are inserted.

# PCI4450 GFN/GJG PC Card and OHCI Controller

SCPS046 – JANUARY 1999

## terminal functions (continued)

**Table 8. System Interrupt**

TERMINAL			I/O TYPE	FUNCTION
NAME	GFN NO.	GJG NO.		
$\overline{\text{INTA}}$ (MFUNC0)	W11	W10	I/O	Parallel PCI interrupt. $\overline{\text{INTA}}$ can be mapped to MFUNC0 when parallel PCI interrupts are used. See <i>programmable interrupt subsystem</i> for details on interrupt signaling. MFUNC0/ $\overline{\text{INTA}}$ defaults to a general-purpose input.
$\overline{\text{INTB}}$ (MFUNC1)	Y11	P10	I/O	Parallel PCI interrupt. $\overline{\text{INTB}}$ can be mapped to MFUNC1 when parallel PCI interrupts are used. See <i>programmable interrupt subsystem</i> for details on interrupt signaling. MFUNC1/ $\overline{\text{INTB}}$ defaults to a general-purpose input.
$\overline{\text{INTC}}$ (MFUNC2)	Y10	P9	I/O	Parallel PCI interrupt. $\overline{\text{INTC}}$ can be mapped to MFUNC2 when parallel PCI interrupts are used. See <i>programmable interrupt subsystem</i> for details on interrupt signaling. MFUNC2/ $\overline{\text{INTC}}$ defaults to a general-purpose input.
IRQSER	W13	P12	I/O	Serial interrupt signal. IRQSER provides the IRQSER-style serial interrupting scheme. Serialized PCI interrupts can also be sent in the IRQSER stream. See <i>programmable interrupt subsystem</i> for details on interrupt signaling.
MFUNC6 MFUNC5 MFUNC4 MFUNC3 MFUNC2 MFUNC1 MFUNC0	Y4 V5 W9 V10 Y10 Y11 W11	R5 W5 T9 R9 P9 P10 W10	O	Interrupt request/secondary functions multiplexed. The primary function of these terminals is to provide programmable options supported by the PCI4450. These interrupt multiplexer outputs can be mapped to various functions. See <i>multifunction routing status register</i> for options.  All of these terminals have secondary functions, such as PCI interrupts, PC/PCI DMA, OHCI LEDs, GPE request/grant, ring indicate output, and zoomed video status, that can be selected with the appropriate programming of this register. When the secondary functions are enabled, the respective terminals are not available for multifunction routing.  See the <i>multifunction routing status register</i> for programming options.
$\overline{\text{RI\_OUT/PME}}$	Y13	R11	O	Ring indicate out and power management event output. Terminal provides an output to the system for ring-indicate or PME signals. Alternately, $\overline{\text{RI\_OUT}}$ can be routed on MFUNC7.

**Table 9. PC/PCI DMA**

TERMINAL			I/O TYPE	FUNCTION
NAME	GFN NO.	GJG NO.		
$\overline{\text{PCGNT}}$ (MFUNC2)	Y10	P9	I/O	PC/PCI DMA grant. $\overline{\text{PCGNT}}$ is used to grant the DMA channel to a requester in a system supporting the PC/PCI DMA scheme. $\overline{\text{PCGNT}}$ is available on MFUNC2 or MFUNC3.  This terminal is also used for the serial EEPROM interface.
$\overline{\text{PCGNT}}$ (MFUNC3)	V10	R9		
$\overline{\text{PCREQ}}$ (MFUNC7)	P20	N19	O	PC/PCI DMA request. $\overline{\text{PCREQ}}$ is used to request DMA transfers as $\overline{\text{DREQ}}$ in a system supporting the PC/PCI DMA scheme. $\overline{\text{PCREQ}}$ is available on MFUNC7, MFUNC4, or MFUNC0.  This terminal is also used for the serial EEPROM interface.
$\overline{\text{PCREQ}}$ (MFUNC4)	W9	T9		
$\overline{\text{PCREQ}}$ (MFUNC0)	W11	W10		



terminal functions (continued)

Table 10. Zoomed Video

TERMINAL			I/O AND MEMORY INTERFACE SIGNAL	I/O TYPE	FUNCTION
NAME	GFN NO.	GJG NO.			
ZV_HREF	P3	N1	A10	O	Horizontal sync to the zoomed video port
ZV_VSYNC	R2	N2	A11	O	Vertical sync to the zoomed video port
ZV_Y7	V1	R1	A20	O	Video data to the zoomed video port in YV:4:2:2 format
ZV_Y6	U2	P6	A14		
ZV_Y5	T3	P5	A19		
ZV_Y4	U1	P4	A13		
ZV_Y3	T2	P2	A18		
ZV_Y2	R3	N6	A8		
ZV_Y1	P4	N5	A17		
ZV_Y0	T1	N4	A9		
ZV_UV7	Y2	W2	A25	O	Video data to the zoomed video port in YV:4:2:2 format
ZV_UV6	W2	U2	A12		
ZV_UV5	Y1	V1	A24		
ZV_UV4	W1	T2	A15		
ZV_UV3	V3	U1	A23		
ZV_UV2	U3	R4	A16		
ZV_UV1	V2	T1	A22		
ZV_UV0	T4	R2	A21		
ZV_SCLK	W3	V2	A7	O	Audio SCLK PCM
ZV_MCLK	W4	W3	A6	O	Audio MCLK PCM
ZV_PCLK	Y3	V4	$\overline{\text{IOIS16}}$	O	Pixel clock to the zoomed video port
ZV_LRCLK	V4	V3	$\overline{\text{INPACK}}$	O	Audio LRCLK PCM
ZV_SDATA	U5	W4	$\overline{\text{SPKR}}$	O	Audio SDATA PCM

# PCI4450 GFN/GJG PC Card and OHCI Controller

SCPS046 – JANUARY 1999

## terminal functions (continued)

**Table 11. Miscellaneous**

TERMINAL			I/O TYPE	FUNCTION
NAME	GFN NO.	GJG NO.		
MFUNC0	W11	W10	I/O	Multifunction terminal 0. Defaults as a general-purpose input (GPI0), and can be programmed to perform various functions. Refer to <i>multifunction routing register</i> description.
MFUNC1	Y11	P10	I/O	Multifunction terminal 1. Defaults as a general-purpose input (GPI1), and can be programmed to perform various functions. Refer to <i>multifunction routing register</i> description.
MFUNC2	Y10	P9	I/O	Multifunction terminal 2. Defaults as a general-purpose input (GPI2), and can be programmed to perform various functions. Refer to <i>multifunction routing register</i> description.
MFUNC3	V10	R9	I/O	Multifunction terminal 3. Defaults as a general-purpose input (GPI3), and can be programmed to perform various functions. Refer to <i>multifunction routing register</i> description.
MFUNC4	W9	T9	I/O	Multifunction terminal 4. Defaults as a high-impedance reserved input, and can be programmed to perform various functions. Refer to <i>multifunction routing register</i> description.
MFUNC5	V5	W5	I/O	Multifunction terminal 5. Defaults as a high-impedance reserved input, and can be programmed to perform various functions. Refer to <i>multifunction routing register</i> description.
MFUNC6	Y4	R5	I/O	Multifunction terminal 6. Defaults as a high-impedance reserved input, and can be programmed to perform various functions. Refer to <i>multifunction routing register</i> description.
IDSEL/MFUNC7	P20	N19	I/O	IDSEL and multifunction terminal 7. Defaults as IDSEL, but may be used as a multifunction terminal. Refer to <i>multifunction routing register</i> description and Section 3.4 for details.
SCL	W10	V9	I/O	Serial ROM clock. This terminal provides the SCL serial clock signaling in a two-wire serial ROM implementation, and is sensed at reset for serial ROM detection.
SDA	Y9	W9	I/O	Serial ROM data. This terminal provides the SDA serial data signaling in a two-wire serial ROM implementation.
$\overline{\text{SPKROUT}}$	V11	T10	O	Speaker output. SPKROUT is the output to the host system that can carry $\overline{\text{SPKR}}$ or CAUDIO through the PCI4450 from the PC Card interface. SPKROUT is driven as the XOR combination of card $\overline{\text{SPKR}}$ //CAUDIO inputs.
$\overline{\text{SUSPEND}}$	U11	R10	I	Suspend. $\overline{\text{SUSPEND}}$ is used to protect the internal registers from clearing when $\overline{\text{PRST}}$ is asserted. See <i>suspend mode</i> for details.





terminal functions (continued)

Table 12. 16-bit PC Card Address and Data (slots A and B)

NAME	TERMINAL				I/O TYPE	FUNCTION
	GFN NO.		GJG NO.			
	SLOT A†	SLOT B‡	SLOT A†	SLOT B‡		
A25	G2	A16	G4	E14	O	PC Card address. 16-bit PC Card address lines. A25 is the most significant bit.
A24	F1	C16	G5	A15		
A23	G4	A18	F2	D15		
A22	E2	C17	F5	B17		
A21	D1	B18	E5	A18		
A20	E4	A20	D2	B19		
A19	D2	C18	C2	D16		
A18	B1	C19	B2	D18		
A17	A2	E17	B3	E16		
A16	E3	B17	E2	A17		
A15	E1	D16	F4	B16		
A14	D3	B19	D1	C18		
A13	C2	B20	B1	C19		
A12	F2	A17	G6	E15		
A11	C4	E18	A4	F15		
A10	C5	E20	F6	G15		
A9	B2	C20	D4	E18		
A8	C3	D18	A2	D19		
A7	G3	B16	G2	B15		
A6	H3	D14	H1	B14		
A5	H1	A15	H4	E13		
A4	J4	C14	H5	B13		
A3	J2	A14	J1	D13		
A2	K2	A13	J5	D12		
A1	K3	D12	J6	E12		
A0	K1	C12	K6	D11		
D15	C6	G18	A6	G18	I/O	PC Card data. 16-bit PC Card data lines. D15 is the most significant bit.
D14	A5	G19	E7	H15		
D13	C7	H18	B7	H18		
D12	B7	H20	G7	H14		
D11	C8	J18	B8	J16		
D10	R1	D9	N7	E9		
D9	P1	B9	M4	B9		
D8	N2	D10	M6	F9		
D7	D7	F20	F7	G13		
D6	B6	G20	D7	H16		
D5	A6	H19	A7	H19		
D4	A7	J17	E8	J15		
D3	B8	J19	A8	J18		
D2	P2	C9	M5	D9		
D1	N3	A9	M1	A9		
D0	N1	C10	L5	E10		

† Terminal name for slot A is preceded with A\_. For example, the full name for terminal G2 is A\_G2.

‡ Terminal name for slot B is preceded with B\_. For example, the full name for terminal A16 is B\_A16.

# PCI4450 GFN/GJG PC Card and OHCI Controller

SCPS046 – JANUARY 1999

## terminal functions (continued)

Table 13. 16-bit PC Card Interface Control (slots A and B)

NAME	TERMINAL GFN NO.		GJG NO.		I/O TYPE	FUNCTION
	SLOT A†	SLOT B‡	SLOT A†	SLOT B‡		
$\overline{\text{BVD1}}$ (STSCHG/RI)	M2	A11	L1	A10	I	<p>Battery voltage detect 1. BVD1 is generated by 16-bit memory PC Cards that include batteries. BVD1 and BVD2 indicate the condition of the batteries on a memory PC Card. Both BVD1 and BVD2 are kept high when the battery is good. When BVD2 is low and BVD1 is high, the battery is weak and should be replaced. When BVD1 is low, the battery is no longer serviceable and the data in the memory PC Card is lost. See ExCA card status-change interrupt configuration register for the enable bits. See ExCA card status-change register and the ExCA interface status register for the status bits for this signal.</p> <p>Status change. STSCHG is used to alert the system to a change in the READY, write protect, or battery voltage dead condition of a 16-bit I/O PC Card.</p> <p>Ring indicate. RI is used by 16-bit modem cards to indicate a ring detection.</p>
$\overline{\text{BVD2}}$ (SPKR)	M1	C11	L6	F10	I	<p>Battery voltage detect 2. BVD2 is generated by 16-bit memory PC Cards that include batteries. BVD2 and BVD1 indicate the condition of the batteries on a memory PC Card. Both BVD1 and BVD2 are high when the battery is good. When BVD2 is low and BVD1 is high, the battery is weak and should be replaced. When BVD1 is low, the battery is no longer serviceable and the data in the memory PC Card is lost. See ExCA card status-change interrupt configuration register for the enable bits. See ExCA card status-change register and the ExCA interface status register for the status bits for this signal.</p> <p>Speaker. SPKR is an optional binary audio signal available only when the card and socket have been configured for the 16-bit I/O interface. The audio signals from cards A and B are combined by the PCI4450 and are output on SPKROUT.</p> <p>DMA request. BVD2 can be used as the DMA request signal during DMA operations to a 16-bit PC Card that supports DMA. The PC Card asserts BVD2 to indicate a request for a DMA operation.</p>
$\overline{\text{CD1}}$ $\overline{\text{CD2}}$	A8 M4	J20 B10	F8 L4	J19 D10	I	<p>PC Card detect 1 and PC Card detect 2. CD1 and CD2 are internally connected to ground on the PC Card. When a PC Card is inserted into a socket, CD1 and CD2 are pulled low. For signal status, see ExCA interface status register.</p>
$\overline{\text{CE1}}$ $\overline{\text{CE2}}$	A4 B4	F19 G17	D6 A5	G16 G14	O	<p>Card enable 1 and card enable 2. CE1 and CE2 enable even- and odd-numbered address bytes. CE1 enables even-numbered address bytes, and CE2 enables odd-numbered address bytes.</p>
$\overline{\text{INPACK}}$	J3	B14	J4	A13	I	<p>Input acknowledge. INPACK is asserted by the PC Card when it can respond to an I/O read cycle at the current address.</p> <p>DMA request. INPACK can be used as the DMA request signal during DMA operations from a 16-bit PC Card that supports DMA. If used as a strobe, the PC Card asserts this signal to indicate a request for a DMA operation.</p>
$\overline{\text{IORD}}$	D5	D20	D5	F16	O	<p>I/O read. IORD is asserted by the PCI4450 to enable 16-bit I/O PC Card data output during host I/O read cycles.</p> <p>DMA write. IORD is used as the DMA write strobe during DMA operations from a 16-bit PC Card that supports DMA. The PCI4450 asserts IORD during DMA transfers from the PC Card to host memory.</p>
$\overline{\text{IOWR}}$	B3	D19	B4	F14	O	<p>I/O write. IOWR is driven low by the PCI4450 to strobe write data into 16-bit I/O PC Cards during host I/O write cycles.</p> <p>DMA read. IOWR is used as the DMA write strobe during DMA operations from a 16-bit PC Card that supports DMA. The PCI4450 asserts IOWR during transfers from host memory to the PC Card.</p>



terminal functions (continued)

Table 13. 16-bit PC Card Interface Control (slots A and B) (continued)

NAME	TERMINAL GFN NO.		GJG NO.		I/O TYPE	FUNCTION
	SLOT A†	SLOT B‡	SLOT A†	SLOT B‡		
$\overline{OE}$	A3	F18	B5	F19	O	Output enable. $\overline{OE}$ is driven low by the PCI4450 to enable 16-bit memory PC Card data output during host memory read cycles. DMA terminal count. $\overline{OE}$ is used as terminal count (TC) during DMA operations to a 16-bit PC Card that supports DMA. The PCI4450 asserts $\overline{OE}$ to indicate TC for a DMA write operation.
READY ( $\overline{IREQ}$ )	L2	A12	K2	E11	I	Ready. The ready function is provided by READY when the 16-bit PC Card and the host socket are configured for the memory-only interface. READY is driven low by the 16-bit memory PC Cards to indicate that the memory card circuits are busy processing a previous write command. READY is driven high when the 16-bit memory PC Card is ready to accept a new data transfer command. Interrupt request. $\overline{IREQ}$ is asserted by a 16-bit I/O PC Card to indicate to the host that a device on the 16-bit I/O PC Card requires service by the host software. $\overline{IREQ}$ is high (deasserted) when no interrupt is requested.
$\overline{REG}$	J1	C13	J2	A12	O	Attribute memory select. $\overline{REG}$ remains high for all common memory accesses. When $\overline{REG}$ is asserted, access is limited to attribute memory ( $\overline{OE}$ or $\overline{WE}$ active) and to the I/O space ( $\overline{IORD}$ or $\overline{IOWR}$ active). Attribute memory is a separately accessed section of card memory and is generally used to record card capacity and other configuration and attribute information. DMA acknowledge. $\overline{REG}$ is used as a DMA acknowledge ( $\overline{DACK}$ ) during DMA operations to a 16-bit PC Card that supports DMA. The PCI4450 asserts $\overline{REG}$ to indicate a DMA operation. $\overline{REG}$ is used in conjunction with the DMA read ( $\overline{IOWR}$ ) or DMA write ( $\overline{IORD}$ ) strobes to transfer data.
RESET	H2	B15	H2	F13	O	PC Card reset. RESET forces a hard reset to a 16-bit PC Card.
$\overline{WAIT}$	L3	B11	K4	F11	I	Bus cycle wait. $\overline{WAIT}$ is driven by a 16-bit PC Card to delay the completion of (i.e., extend) the memory or I/O cycle in progress.
$\overline{WE}$	C1	A19	E4	B18	O	Write enable. $\overline{WE}$ is used to strobe memory write data into 16-bit memory PC Cards. $\overline{WE}$ is also used for memory PC Cards that employ programmable memory technologies. DMA terminal count. $\overline{WE}$ is used as TC during DMA operations to a 16-bit PC Card that supports DMA. The PCI4450 asserts $\overline{WE}$ to indicate TC for a DMA read operation.
WP ( $\overline{IOIS16}$ )	M3	A10	L2	B10	I	Write protect. WP applies to 16-bit memory PC Cards. WP reflects the status of the write-protect switch on 16-bit memory PC Cards. For 16-bit I/O cards, WP is used for the 16-bit port ( $\overline{IOIS16}$ ) function. I/O is 16 bits. $\overline{IOIS16}$ applies to 16-bit I/O PC Cards. $\overline{IOIS16}$ is asserted by the 16-bit PC Card when the address on the bus corresponds to an address to which the 16-bit PC Card responds, and the I/O port that is addressed is capable of 16-bit accesses. DMA request. WP can be used as the DMA request signal during DMA operations to a 16-bit PC Card that supports DMA. If used, the PC Card asserts WP to indicate a request for a DMA operation.
$\overline{VS1}$ $\overline{VS2}$	L1 G1	B12 C15	K1 H6	B11 A14	I/O	Voltage sense 1 and voltage sense 2. $\overline{VS1}$ and $\overline{VS2}$ , when used in conjunction with each other, determine the operating voltage of the 16-bit PC Card.

† Terminal name for slot A is preceded with A\_. For example, the full name for terminal C1 is A\_ $\overline{WE}$ .

‡ Terminal name for slot B is preceded with B\_. For example, the full name for terminal A19 is B\_ $\overline{WE}$ .

# PCI4450 GFN/GJG PC Card and OHCI Controller

SCPS046 – JANUARY 1999

## terminal functions (continued)

**Table 14. CardBus PC Card Interface System (slots A and B)**

NAME	TERMINAL GFN NO.		GJG NO.		I/O TYPE	FUNCTION
	SLOT A†	SLOT B‡	SLOT A†	SLOT B‡		
CCLK	E3	B17	E2	A17	O	CardBus PC Card clock. CCLK provides synchronous timing for all transactions on the CardBus interface. All signals except $\overline{\text{CRST}}$ , $\overline{\text{CCLKRUN}}$ , $\overline{\text{CINT}}$ , $\overline{\text{CSTSCHG}}$ , $\overline{\text{CAUDIO}}$ , $\overline{\text{CCD2}}$ , $\overline{\text{CCD1}}$ , and $\overline{\text{CVS2-CVS1}}$ are sampled on the rising edge of CCLK, and all timing parameters are defined with the rising edge of this signal. CCLK operates at the PCI bus clock frequency, but it can be stopped in the low state or slowed down for power savings.
$\overline{\text{CCLKRUN}}$	M3	A10	L2	B10	O	CardBus PC Card clock run. $\overline{\text{CCLKRUN}}$ is used by a CardBus PC Card to request an increase in the CCLK frequency, and by the PCI4450 to indicate that the CCLK frequency is decreased. CardBus clock run ( $\overline{\text{CCLKRUN}}$ ) follows the PCI clock run ( $\overline{\text{CLKRUN}}$ ).
$\overline{\text{CRST}}$	H2	B15	H2	F13	I/O	CardBus PC Card reset. $\overline{\text{CRST}}$ is used to bring CardBus PC Card-specific registers, sequencers, and signals to a known state. When $\overline{\text{CRST}}$ is asserted, all CardBus PC Card signals must be placed in a high-impedance state, and the PCI4450 drives these signals to a valid logic level. Assertion can be asynchronous to CCLK, but deassertion must be synchronous to CCLK.

† Terminal name for slot A is preceded with A\_. For example, the full name for terminal E3 is A\_CCLK.

‡ Terminal name for slot B is preceded with B\_. For example, the full name for terminal B17 is B\_CCLK.



terminal functions (continued)

Table 15. CardBus PC Card Address and Data (slots A and B)

NAME	TERMINAL				I/O TYPE	FUNCTION
	GFN NO.		GJG NO.			
	SLOT A†	SLOT B‡	SLOT A†	SLOT B‡		
CAD31	R1	D9	N7	E9	I/O	PC Card address and data. These signals make up the multiplexed CardBus address and data bus on the CardBus interface. During the address phase of a CardBus cycle, CAD31–CAD0 contain a 32-bit address. During the data phase of a CardBus cycle, CAD31–CAD0 contain data. CAD31 is the most significant bit.
CAD30	P1	B9	M4	B9		
CAD29	N3	A9	M1	A9		
CAD28	N2	D10	M6	F9		
CAD27	N1	C10	L5	E10		
CAD26	K1	C12	K6	D11		
CAD25	K3	D12	J6	E12		
CAD24	K2	A13	J5	D12		
CAD23	J2	A14	J1	D13		
CAD22	J4	C14	H5	B13		
CAD21	H1	A15	H4	E13		
CAD20	H3	D14	H1	B14		
CAD19	G2	A16	G4	E14		
CAD18	G3	B16	G2	B15		
CAD17	F1	C16	G5	A15		
CAD16	A2	E17	B3	E16		
CAD15	B3	D19	B4	F14		
CAD14	B2	C20	D4	E18		
CAD13	D5	D20	D5	F16		
CAD12	C4	E18	A4	F15		
CAD11	A3	F18	B5	F19		
CAD10	B4	G17	A5	G14		
CAD9	C5	E20	F6	G15		
CAD8	C6	G18	A6	G18		
CAD7	D7	F20	F7	G13		
CAD6	C7	H18	B7	H18		
CAD5	B6	G20	D7	H16		
CAD4	B7	H20	G7	H14		
CAD3	A6	H19	A7	H19		
CAD2	C8	J18	B8	J16		
CAD1	A7	J17	E8	J15		
CAD0	B8	J19	A8	J18		
CC/BE3	J1	C13	J2	A12	I/O	CardBus bus commands and byte enables. CC/BE3–CC/BE0 are multiplexed on the same CardBus terminals. During the address phase of a CardBus cycle, CC/BE3–CC/BE0 defines the bus command. During the data phase, this 4-bit bus is used as byte enables. The byte enables determine which byte paths of the full 32-bit data bus carry meaningful data. CC/BE0 applies to byte 0 (CAD7–CAD0), CC/BE1 applies to byte 1 (CAD15–CAD8), CC/BE2 applies to byte 2 (CAD23–CAD16), and CC/BE3 applies to byte 3 (CAD31–CAD24).
CC/BE2	F2	A17	G6	E15		
CC/BE1	C3	D18	A2	D19		
CC/BE0	A4	F19	D6	G16		
CPAR	C2	B20	B1	C19	I/O	CardBus parity. In all CardBus read and write cycles, the PCI4450 calculates even parity across the CAD and CC/BE buses. As an initiator during CardBus cycles, the PCI4450 outputs CPAR with a one-CCLK delay. As a target during CardBus cycles, the calculated parity is compared to the initiator's parity indicator; a compare error results in a parity error assertion.

† Terminal name for slot A is preceded with A\_. For example, the full name for terminal C2 is A\_CPAR.

‡ Terminal name for slot B is preceded with B\_. For example, the full name for terminal B20 is B\_CPAR.

# PCI4450 GFN/GJG PC Card and OHCI Controller

SCPS046 – JANUARY 1999

## terminal functions (continued)

Table 16. CardBus PC Card Interface Control (slots A and B)

NAME	TERMINAL GFN NO.		GJG NO.		I/O TYPE	FUNCTION
	SLOT A†	SLOT B‡	SLOT A†	SLOT B‡		
CAUDIO	M1	C11	L6	F10	I	CardBus audio. CAUDIO is a digital input signal from a PC Card to the system speaker. The PCI4450 supports the binary audio mode and outputs a binary signal from the card to SPKROUT.
CBLOCK	D2	C18	C2	D16	I/O	CardBus lock. CBLOCK is used to gain exclusive access to a target.
CCD1 CCD2	A8 M4	J20 B10	F8 L4	J19 D10	I	CardBus detect 1 and CardBus detect 2. CCD1 and CCD2 are used in conjunction with CVS1 and CVS2 to identify card insertion and interrogate cards to determine the operating voltage and card type.
CDEVSEL	D1	B18	E5	A18	I/O	CardBus device select. The PCI4450 asserts CDEVSEL to claim a CardBus cycle as the target device. As a CardBus initiator on the bus, the PCI4450 monitors CDEVSEL until a target responds. If no target responds before timeout occurs, then the PCI4450 terminates the cycle with an initiator abort.
CFRAME	G4	A18	F2	D15	I/O	CardBus cycle frame. CFRAME is driven by the initiator of a CardBus bus cycle. CFRAME is asserted to indicate that a bus transaction is beginning, and data transfers continue while this signal is asserted. When CFRAME is deasserted, the CardBus bus transaction is in the final data phase.
CGNT	C1	A19	E4	B18	I	CardBus bus grant. CGNT is driven by the PCI4450 to grant a CardBus PC Card access to the CardBus bus after the current data transaction has been completed.
CINT	L2	A12	K2	E11	I	CardBus interrupt. CINT is asserted low by a CardBus PC Card to request interrupt servicing from the host.
CIRDY	E1	D16	F4	B16	I/O	CardBus initiator ready. CIRDY indicates the CardBus initiator's ability to complete the current data phase of the transaction. A data phase is completed on a rising edge of CCLK when both CIRDY and CTRDY are asserted. Until CIRDY and CTRDY are both sampled asserted, wait states are inserted.
CPERR	D3	B19	D1	C18	I/O	CardBus parity error. CPERR is used to report parity errors during CardBus transactions, except during special cycles. It is driven low by a target two clocks following that data when a parity error is detected.
CREQ	J3	B14	J4	A13	I	CardBus request. CREQ indicates to the arbiter that the CardBus PC Card desires use of the CardBus bus as an initiator.
CSERR	L3	B11	K4	F11	I	CardBus system error. CSERR reports address parity errors and other system errors that could lead to catastrophic results. CSERR is driven by the card synchronous to CCLK, but deasserted by a weak pullup, and may take several CCLK periods. The PCI4450 can report CSERR to the system by assertion of SERR on the PCI interface.
CSTOP	E4	A20	D2	B19	I/O	CardBus stop. CSTOP is driven by a CardBus target to request the initiator to stop the current CardBus transaction. CSTOP is used for target disconnects, and is commonly asserted by target devices that do not support burst data transfers.
CSTSCHG	M2	A11	L1	A10	I	CardBus status change. CSTSCHG is used to alert the system to a change in the card's status and is used as a wake-up mechanism.
CTRDY	E2	C17	F5	B17	I/O	CardBus target ready. CTRDY indicates the CardBus target's ability to complete the current data phase of the transaction. A data phase is completed on a rising edge of CCLK, when both CIRDY and CTRDY are asserted; until this time, wait states are inserted.
CVS1 CVS2	L1 G1	B12 C15	K1 H6	B11 A14	I/O	CardBus voltage sense 1 and CardBus voltage sense 2. CVS1 and CVS2 are used in conjunction with CCD1 and CCD2 to identify card insertion and interrogate cards to determine the operating voltage and card type.

† Terminal name for slot A is preceded with A\_. For example, the full name for terminal M1 is A\_CAUDIO.

‡ Terminal name for slot B is preceded with B\_. For example, the full name for terminal C11 is B\_CAUDIO.



terminal functions (continued)

Table 17. IEEE1394 PHY/Link Interface Terminals

NAME	TERMINAL		I/O TYPE	FUNCTION
	GFN NO.	GJG NO.		
PHY_CTL1 PHY_CTL0	W6 U7	V6 W6	I/O	Phy-link interface control. These bi-direction signals control passage of information between the PHY and link. The link can only drive these terminals after the PHY has granted permission following a link request (LREQ).
PHY_DATA7 PHY_DATA6 PHY_DATA5 PHY_DATA4 PHY_DATA3 PHY_DATA2 PHY_DATA1 PHY_DATA0	V9 U9 Y8 W8 V8 Y7 W7 V7	R8 T8 V8 W8 P8 W7 V7 R7	I/O	Phy-link interface data. These bi-directional signals pass data between the PHY and link. These terminals are driven by the link on transmissions and are driven by the PHY on receptions. Only DATA1–DATA0 are valid for 100 Mbit speed. DATA4–DATA0 are valid for 200 Mbit speed and DATA7–DATA0 are valid for 400 Mbit speed.
PHY_CLK	V6	T6	I	System clock. This input provides a 49.152 MHz clock signal for data synchronization.
PHY_LREQ	Y5	R6	O	Link request. This signal is driven by the link to initiate a request for the PHY to perform some service.
LINKON	Y6	P7	I	1394 link on. This input from the PHY indicates that the link should turn on.
LPS	W5	V5	O	Link power status. LPS indicates that link is powered and fully functional.

I/O characteristics

Figure 3 shows a 3-state bidirectional buffer illustration for reference. The table, *recommended operating conditions* provides the electrical characteristics of the inputs and outputs. The PCI4450 meets the ac specifications of the PC Card 95 Standard and the PCI Bus 2.1 specifications.

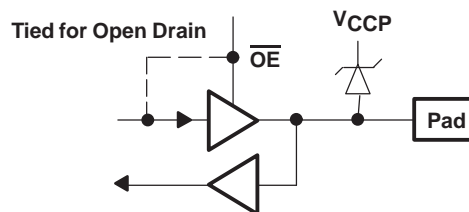

Figure 3. 3-State Bidirectional Buffer

clamping voltages

The I/O sites can be pulled through a clamping diode to a voltage rail for protection. The 3.3-V core power supply is independent of the clamping voltages. The clamping (protection) diodes are required if the signaling environment on an I/O is system dependent. For example, PCI signaling can be either 3.3 Vdc or 5.0 Vdc, and the PCI4450 must reliably accommodate both voltage levels. This is accomplished by using a 3.3-V buffer with a clamping diode to V<sub>CCP</sub>. If a system design requires a 5.0-V PCI bus, then the V<sub>CCP</sub> would be connected to the 5.0-V power supply.

A standard die has only one clamping voltage for the sites as shown in Figure 3. After the terminal assignments are fixed, the fabrication facility will support a design by splitting the clamping voltage for customization. The PCI4450 requires five separate clamping voltages since it supports a wide range of features. The five voltages are listed and defined in the table, *recommended operating conditions*.

## PCI interface

This section describes the PCI interface of the PCI4450, and how the device responds to and participates in PCI bus cycles. The PCI4450 provides all required signals for PCI master/slave devices and may operate in either 5-V or 3.3-V PCI signaling environments by connecting the  $V_{CCP}$  terminals to the desired signaling level.

### PCI bus lock ( $\overline{LOCK}$ )

The bus locking protocol defined in the PCI Specification is not highly recommended, but is provided on the PCI4450 as an additional compatibility feature. The PCI  $\overline{LOCK}$  terminal is multiplexed with GPIO2, and the terminal function defaults to a general-purpose input (GPI). The use of  $\overline{LOCK}$  is only supported by PCI-to-CardBus bridges in the downstream direction (away from the processor).

PCI  $\overline{LOCK}$  indicates an atomic operation that may require multiple transactions to complete. When  $\overline{LOCK}$  is asserted, nonexclusive transactions may proceed to an address that is not currently locked. A grant to start a transaction on the PCI bus does not guarantee control of  $\overline{LOCK}$ ; control of  $\overline{LOCK}$  is obtained under its own protocol. It is possible for different initiators to use the PCI bus while a single master retains ownership of  $\overline{LOCK}$ . To avoid confusion with the PCI bus clock, the CardBus signal for this protocol is  $\overline{CBLOCK}$ .

An agent may need to do an exclusive operation because a critical memory access to memory might be broken into several transactions, but the master wants exclusive rights to a region of memory. The granularity of the lock is defined by PCI to be 16 bytes aligned. The lock protocol defined by PCI allows a resource lock without interfering with nonexclusive, real-time data transfer, such as video.

The PCI bus arbiter may be designed to support only complete bus locks using the  $\overline{LOCK}$  protocol. In this scenario the arbiter will not grant the bus to any other agent (other than the  $\overline{LOCK}$  master) while  $\overline{LOCK}$  is asserted. A complete bus lock may have a significant impact on the performance of the video. The arbiter that supports complete bus lock must grant the bus to the cache to perform a writeback due to a snoop to a modified line when a locked operation is in progress.

The PCI4450 supports all  $\overline{LOCK}$  protocol associated with PCI-to-PCI bridges, as also defined for PCI-to-CardBus bridges. This includes disabling write posting while a locked operation is in progress, which can solve a potential deadlock when using devices such as PCI-to-PCI bridges. The potential deadlock can occur if a CardBus target supports delayed transactions and blocks access as the target until it completes a delayed read. This target characteristic is prohibited by the 2.1 PCI Specification, and the issue is resolved by the PCI master using  $\overline{LOCK}$ .

### loading the subsystem identification (EEPROM interface)

The subsystem vendor ID register and subsystem ID register make up a double word of PCI configuration space located at offset 40h for functions 0 and 1. This doubleword register, used for system and option card (mobile dock) identification purposes, is required by some operating systems. Implementation of this unique identifier register is a PC '97 requirement.

The PCI4450 offers two mechanisms to load a read-only value into the subsystem registers. The first mechanism relies upon the system BIOS providing the subsystem ID value. The default access mode to the subsystem registers is read-only, but the access mode may be made read/write by clearing the SUBSYSRW bit in the system control register (bit 5 of the system control register, offset 80h). Once this bit is cleared (0), the BIOS may write a subsystem identification value into the registers at offset 40h. The BIOS must set the SUBSYSRW bit such that the subsystem vendor ID register and subsystem ID register are limited to read-only access. This approach saves the added cost of implementing the serial EEPROM.

In some conditions, such as in a docking environment, the subsystem vendor ID register and subsystem ID register must be loaded with a unique identifier through a serial EEPROM interface. The PCI4450 loads the double-word of data from the serial EEPROM after a reset of the primary bus. The  $\overline{SUSPEND}$  input gates the



$\overline{PRST}$  and  $\overline{G\_RST}$  from the entire PCI4450 core, including the serial EEPROM state machine. Refer to *suspend mode* for details on using  $\overline{SUSPEND}$ . The PCI4450 provides a two-line serial bus interface to the serial EEPROM.

The system designer must implement a pull-down resistor on the PCI4450 LATCH terminal to indicate the serial EEPROM mode. Only when this pull-down resistor is present will the PCI4450 attempt to load data through the serial EEPROM interface. The serial EEPROM interface is a two-pin interface with one data signal (SDA) and one clock signal (SCL). Figure 4 illustrates a typical PCI4450 application using the serial EEPROM interface.

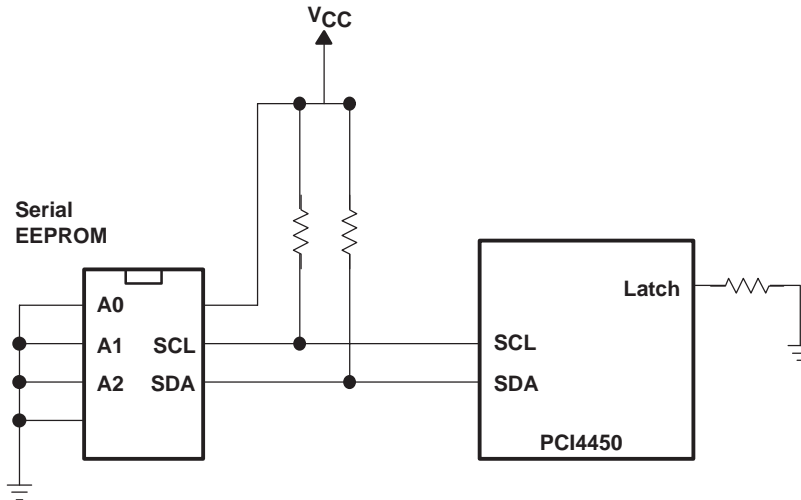
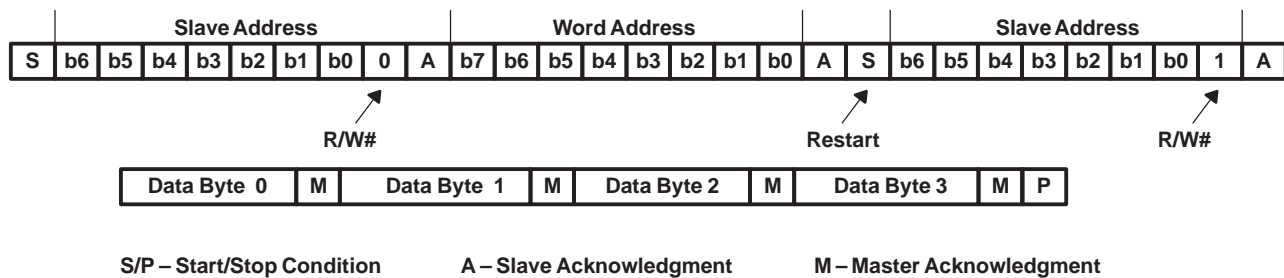

Figure 4. Serial EEPROM Application

As stated above, when the PCI4450 is reset by  $\overline{G\_RST}$ , the subsystem data is read automatically from the EEPROM. The PCI4450 masters the serial EEPROM bus and reads four bytes as described in Figure 5.



S/P – Start/Stop Condition      A – Slave Acknowledgment      M – Master Acknowledgment

Figure 5. EEPROM Interface Subsystem Data Collection

The EEPROM is addressed at slave address A0h (1010 0000b), as indicated in Figure 5, and the EEPROM word address auto-increments after each byte transfers according to the protocol. All hardware address bits for the EEPROM should be tied to the appropriate level to achieve this slave address. Thus, to provide the subsystem register with data AABBCDDh the EEPROM should be programmed with address 0 = AAh, 1 = BBh, 2 = CCh, and 3 = DDh.

The serial EEPROM chip in the sample application circuit, Figure 4, assumes the 1010b high address nibble. The lower three address bits are terminal inputs to the chip, and the sample application shows these terminal inputs tied to GND.

The serial EEPROM interface signals require pullup resistors. The serial EEPROM protocol allows bidirectional transfers. Both the SCL and SDA signals are placed in a high-impedance state and pulled high when the bus is not active. A high-to-low transition of the SDA line defines a start condition (S). A low-to-high transition of SDA while SCL is high is defined as the stop condition (P). One bit is transferred during each clock pulse. The data

on the SDA line must remain stable during the high period of the clock pulse, as changes in the data line at this time will be interpreted as a control signal. Data is valid and stable during the clock high period. Figure 6 illustrates this protocol.

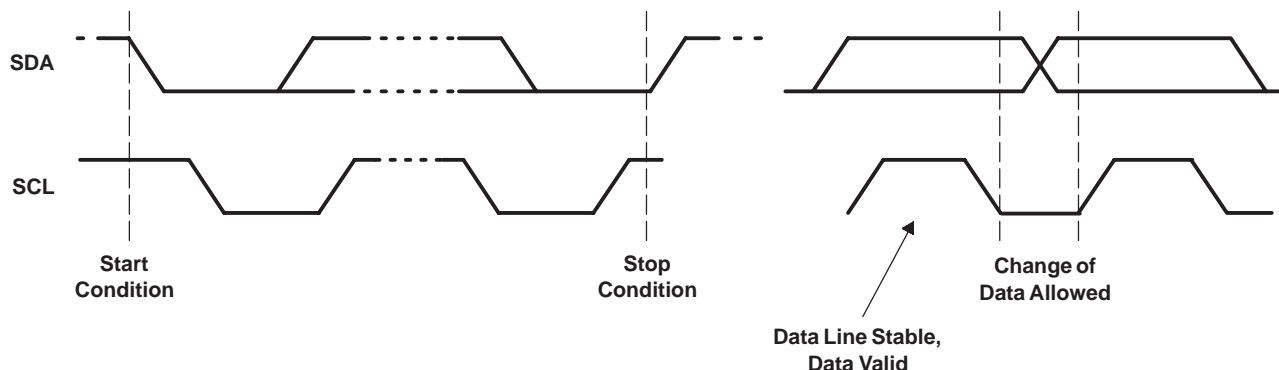

Figure 6. Serial EEPROM Start/Stop Conditions and Bit Transfers

Each address byte and data transfer is followed by an acknowledge bit, as indicated in Figure 5. When the PCI4450 transmits the addresses, it returns the SDA signal to the high state and places the line in a high-impedance state. The PCI4450 then generates an SCL clock cycle and expects the EEPROM to pull down the SDA line during the acknowledge pulse. This procedure is referred to as a slave acknowledge with the PCI4450 transmitter and the EEPROM receiver. Figure 7 illustrates general acknowledges.

During the data byte transfers from the serial EEPROM to the PCI4450, the EEPROM clocks the SCL signal. After the EEPROM transmits the data to the PCI4450, it returns the SDA signal to the high state and places the line in a high-impedance state. The EEPROM then generates an SCL clock cycle and expects the PCI4450 to pull down the SDA line during the acknowledge pulse. This procedure is referred to as a master acknowledge with the EEPROM transmitter and the PCI4450 receiver. Figure 7 illustrates general acknowledges.

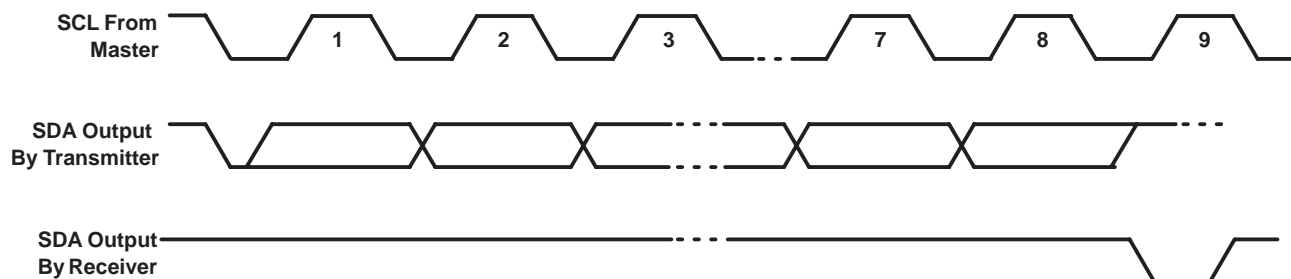

Figure 7. Serial EEPROM Protocol – Acknowledge

EEPROM interface status information is communicated through the general status register located at PCI offset 85h. The EEDETECT bit in this register indicates whether or not the PCI4450 serial EEPROM circuitry detects the pulldown resistor on LATCH. An error condition, such as a missing acknowledge, results in the DATAERR bit being set. The EEBUSY bit is set while the subsystem ID register is loading (serial EEPROM interface is busy).

### serial ROM implementation

A serial ROM interface exists in both the Open HCI function and the PC Card controller functions. The PCI4450 implementation adds a busy indication between the interfaces to allow the function 2 loading to follow the functions 0 and 1 load. All serial ROM addressing uses slave address 8'hA0. The functions 0 and 1 serial EEPROM state machine is modified to provide a busy indication to function 2 and to start loading registers at word address 8'h20 to allow for some serial ROM format flexibility in function 2.

Primarily, the serial ROM is used to preload the PCI4450 registers with data, and only write accessible bits in these registers may be preloaded. Figure 8 illustrates the PCI4450 serial ROM data format, which is an expanded version of both the OHCI-Lynx and PCI1450 serial ROM formats.

Slave Address 8'b10100000

MaxLat / MinGnt	Word address 0
SubSys byte 0	Word address 1
SubSys byte 1	Word address 2
SubSys byte 2	Word address 3
SubSys byte 3	Word address 4
Link_Enh byte 0	Word address 5
MiniROM_Addr	Word address 6
GUIDHi byte 0	Word address 7
GUIDHi byte 1	Word address 8
GUIDHi byte 2	Word address 9
GUIDHi byte 3	Word address 10
GUIDLo byte 0	Word address 11
GUIDLo byte 1	Word address 12
GUIDLo byte 2	Word address 13
GUIDLo byte 3	Word address 14
Checksum	Word address 15
Link_Enh byte 1	Word address 16
PCI misc byte 0	Word address 17
PCI misc byte 1	Word address 18
RSVD	

Flag byte	Word address 32 (20h)
SubSys byte 3	Word address 33
SubSys byte 2	Word address 34
SubSys byte 1	Word address 35
SubSys byte 0	Word address 36
SysCtrl byte 0	Word address 37
SysCtrl byte 1	Word address 38
SysCtrl byte 2	Word address 39
SysCtrl byte 3	Word address 40
General control	Word address 41
GP event enable	Word address 42
GP output	Word address 43
MF route byte 0	Word address 44
MF route byte 1	Word address 45
MF route byte 2	Word address 46
MF route byte 3	Word address 47
Card Control	Word address 48
Device control	Word address 49
Diagnostic	Word address 50
PMC byte 1	Word address 51
ExCA ID and rev	Word address 52
...	
AVAIL	

**Figure 8. Serial ROM Data Format**

The flag byte at word address 32 indicates to the PCI4450 whether or not the PC Card controller functions loads the data from word address range 33–52. A flag byte set to 8'hFF indicates to stop loading the serial ROM data for functions 0 and 1, but is independent of the function 2 1394 Open HCI controller load from word address range 0–18.

An additional change in the serial ROM behavior with respect to Open HCI GUIDROM register access is the MiniROM\_Addr. The MiniROM\_Addr field in the ROM data is loaded from byte location 6 (EEPROM word address 6) and indicates to function 2 where to begin accessing the serial ROM via the GUID ROM register. The GUIDROM.addrReset bit function changes slightly to reset serial ROM access to the byte location indicated by MiniROM\_Addr. A MiniROM\_Addr value of zero provides identical operation as the OHCI-Lynx.

# PCI4450 GFN/GJG PC Card and OHCI Controller

SCPS046 – JANUARY 1999

## PC Card applications overview

This section describes the PC Card interfaces of the PCI4450. A discussion on PC Card recognition details the card interrogation procedure. This section discusses the card powering procedure, including the protocol of the P<sup>2</sup>C power switch interface. The internal ZV buffering provided by the PCI4450 and programming model is detailed in this section. Also, standard PC Card register models are described, as well as a brief discussion of the PC Card software protocol layers.

## PC Card insertion/removal and recognition

The 1995 PC Card Standard addresses the card detection and recognition process through an interrogation procedure that the socket must initiate upon card insertion into a cold, unpowered socket. Through this interrogation, card voltage requirements and interface (16-bit vs. CardBus) are determined.

The scheme uses the  $\overline{CD1}$ ,  $\overline{CD2}$ ,  $\overline{VS1}$ , and  $\overline{VS2}$  signals ( $\overline{CCD1}$ ,  $\overline{CCD2}$ , CVS1, CVS2 for CardBus). A PC Card designer connects these four pins in a certain configuration depending on the type of card and the supply voltage. The encoding scheme for this, defined in the 1997 PC Card Standard, is shown in Table 18.

**Table 18. PC Card – Card Detect and Voltage Sense Connections**

$\overline{CD2}/\overline{CCD2}$	$\overline{CD1}/\overline{CCD1}$	$\overline{VS2}/CVS2$	$\overline{VS1}/CVS1$	Key	Interface	Voltage
Ground	Ground	Open	Open	5 V	16-bit PC Card	5 V
Ground	Ground	Open	Ground	5 V	16-bit PC Card	5 V and 3.3 V
Ground	Ground	Ground	Ground	5 V	16-bit PC Card	5 V, 3.3 V, and X.X V
Ground	Ground	Open	Ground	LV	16-bit PC Card	3.3 V
Ground	Connect to CVS1	Open	Connect to $\overline{CCD1}$	LV	CardBus PC Card	3.3 V
Ground	Ground	Ground	Ground	LV	16-bit PC Card	3.3 V and X.X V
Connect to CVS2	Ground	Connect to $\overline{CCD2}$	Ground	LV	CardBus PC Card	3.3 V and X.X V
Connect to CVS1	Ground	Ground	Connect to $\overline{CCD2}$	LV	CardBus PC Card	3.3 V, X.X V, and Y.Y V
Ground	Ground	Ground	Open	LV	16-bit PC Card	Y.Y V
Connect to CVS2	Ground	Connect to $\overline{CCD2}$	Open	LV	CardBus PC Card	Y.Y V
Ground	Connect to CVS2	Connect to $\overline{CCD1}$	Open	LV	CardBus PC Card	X.X V and Y.Y V
Connect to CVS1	Ground	Open	Connect to $\overline{CCD2}$	LV	CardBus PC Card	Y.Y V
Ground	Connect to CVS1	Ground	Connect to $\overline{CCD1}$		Reserved	
Ground	Connect to CVS2	Connect to $\overline{CCD1}$	Ground		Reserved	

## P<sup>2</sup>C power switch interface (TPS2202A/2206)

A power switch with a PCMCIA-to-peripheral control (P<sup>2</sup>C) interface is required for the PC Card powering interface. The TI TPS2206 (or TPS2202A) Dual-Slot PC Card Power-Interface Switch provides the P<sup>2</sup>C interface to the CLOCK, DATA, and LATCH terminals of the PCI4450. Figure 9 shows the terminal assignments of the TPS2206. Figure 10 illustrates a typical application where the PCI4450 represents the PCMCIA controller.

There are two ways to provide a clock source to the power switch interface. The first method is to provide an external clock source such as a 32 kHz real time clock to the CLOCK terminal. The second method is to use the internal ring oscillator. If the internal ring oscillator is used, then the PCI4450 provides its own clock source for the PC Card interrogation logic and the power switch interface. The mode of operation is determined by the setting of bit 27 of the system control register (PCI offset 80h). This bit is encoded as follows:

0 = CLOCK terminal (terminal U12) is an input (default).

1 = CLOCK terminal is an output that utilizes the internal oscillator.



A 43 kΩ pulldown resistor should be tied to the CLOCK pin.

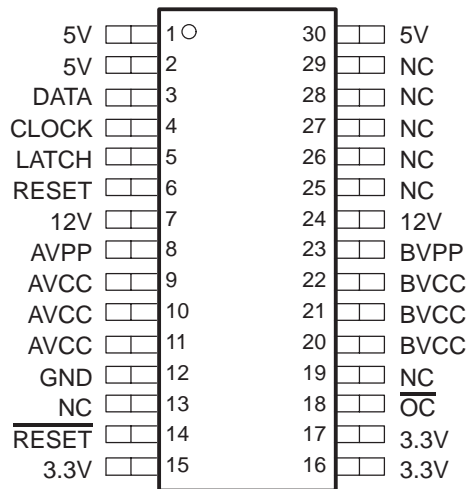

NC – No internal connection

Figure 9. TPS2206 Terminal Assignments

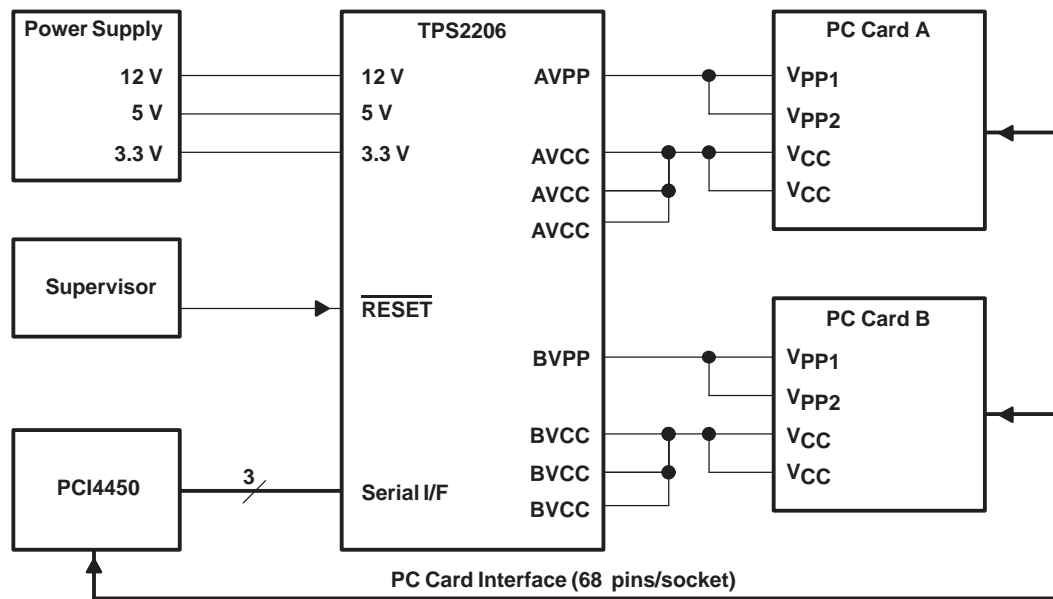

Figure 10. TPS2206 Typical Application

### zoomed video support

The zoomed video (ZV) port on the PCI4450 provides an internally buffered 16-bit ZV PC Card data path. This internal routing is programmed through the multimedia control register. Figure 10 summarizes the zoomed video subsystem implemented in the PCI4450, and details the bit functions found in the multimedia control register.

# PCI4450 GFN/GJG PC Card and OHCI Controller

SCPS046 – JANUARY 1999

An output port (PORTSEL) is always selected. The PCI4450 defaults to socket 0 (see the multimedia control register). When ZVOUTEN is enabled, the zoomed video output terminals are enabled and allow the PCI4450 to route the zoomed video data. However, no data is transmitted unless either ZVEN0 or ZVEN1 is enabled in the multimedia control register. If the PORTSEL maps to a card port that is disabled (ZVEN = 0 or ZVEN1 = 0), then the zoomed video port is driven low (i.e., no data is transmitted).

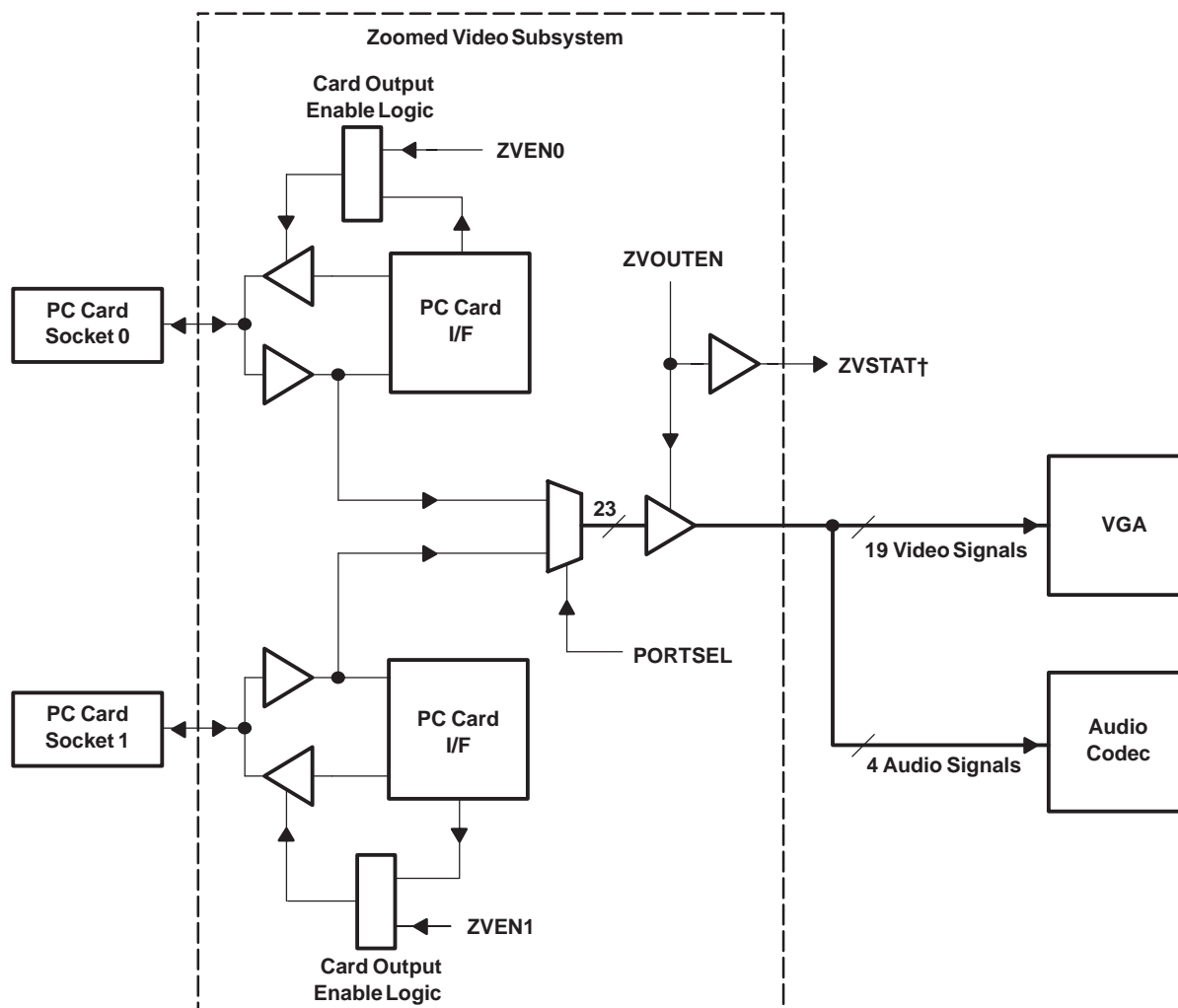

† ZVSTAT must be enabled through the GPIO Control Register.

**Figure 11. Zoomed Video Subsystem**

## zoomed video auto detect

Zoomed video auto detect, when enabled, allows the PCI4450 to automatically detect zoomed video data by sensing the pixel clock from each socket and/or from a third zoomed video source that may exist on the motherboard. The PCI4450 automatically switches the internal zoomed video MUX to route the zoomed video stream to the PCI4450's zoomed video output port. This eliminates the need for software to switch the internal MUX using the multimedia control register (PCI offset 84h, bits 6 and 7).

The PCI4450 can be programmed to switch a third zoomed video source by programming MFUNC2 or MFUNC3 as a zoomed video pixel clock sense pin and connecting this pin to the pixel clock of the third zoomed video source. ZVSTAT may then be programmed onto MFUNC4, MFUNC1, or MFUNC0 and this signal may switch the zoomed video buffers from the third zoomed video source. To account for the possibility of several zoomed video sources being enabled at the same time, a programmable priority scheme may be enabled.

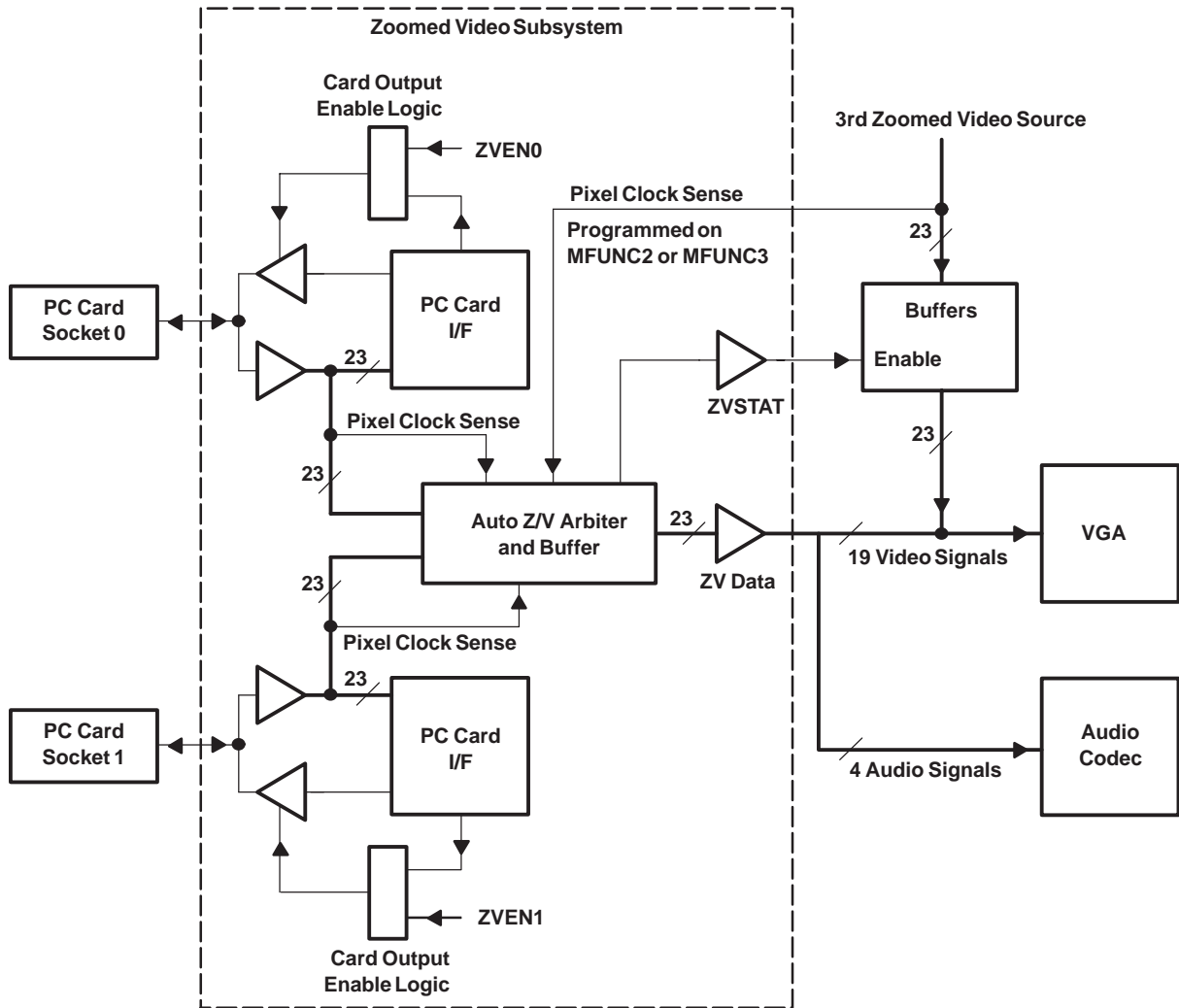

Figure 12. Zoomed Video with Auto Detect Enabled

The PCI4450 defaults with zoomed video auto-detect disabled so that it will function exactly like the PCI1250A and PCI1450. To enable zoomed video auto-detect and the programmable priority scheme, the following bits must be set:

- Multimedia control register (PCI offset 84h) bit 5: Writing a 1b enables zoomed video auto-detect
- Multimedia control register (PCI offset 84h) bits 4–2: Set the programmable priority scheme

- 000 = Slot A, Slot B, External Source
- 001 = Slot A, External Source, Slot B
- 010 = Slot B, Slot A, External Source
- 011 = Slot B, External Source, Slot A
- 100 = External Source, Slot A, Slot B
- 101 = External Source, Slot B, Slot A
- 110 = External Source, Slot B, Slot A
- 111 = Reserved

# PCI4450 GFN/GJG PC Card and OHCI Controller

SCPS046 – JANUARY 1999

If it is desired to switch a third zoomed video source, then the following bits must also be set:

- MFUNC routing register (PCI offset 8Ch), bits 14–12 or 10–8: Write 111b to program MFUNC3 or MFUNC2 as a pixel clock input pin.
- MFUNC routing register (PCI offset 8Ch), bits 18–16, 6–4, or 2–0: Write 111b to program MFUNC4, MFUNC1, or MFUNC0 pin.

## ultra zoomed video

Ultra zoomed video is an enhancement to the PCI4450's DMA engine and is intended to improve the 16-bit bandwidth for MPEG I and MPEG II decoder PC Cards. This enhancement allows the 4450 to fetch 32 bits of data from memory versus the 11XX/12XX 16-bit fetch capability. This enhancement allows a higher sustained throughput to the 16-bit PC Card, because the 4450 prefetches an extra 16 bits (32 bits total) during each PCI read transaction. If the PCI Bus becomes busy, then the 4450 has an extra 16 bits of data to perform back-to-back 16-bit transactions to the PC Card before having to fetch more data. This feature is built into the DMA engine and software is not required to enable this enhancement.

**NOTE:** The 11XX and 12XX series CardBus controllers have enough 16-bit bandwidth to support MPEG II PC Card decoders. But it was decided to improve the bandwidth even more in the 14XX series CardBus controllers.

## D3\_STAT pin

Additional functionality added for the 4450 versus the 1250A/1251 series is the  $\overline{D3\_STAT}$  (D3 status) pin. This pin is asserted under the following two conditions (both conditions must be true before  $\overline{D3\_STAT}$  is asserted):

- Function 0 and Function 1 are placed in D3
- $\overline{PME}$  is enabled on either function

The intent of including this feature in the PCI4450 is to use this pin to switch an external  $V_{CC}/V_{AUX}$  switch. This feature can be programmed on MFUNC7, MFUNC6, MFUNC2, or MFUNC1 by writing 100b to the appropriate multifunction routing status register bits (PCI offset 8Ch).

## internal ring oscillator

The internal ring oscillator provides an internal clock source for the PCI4450 so that neither the PCI clock nor an external clock is required in order for the PCI4450 to power down a socket or interrogate a PC Card. This internal oscillator operates nominally at 16 kHz and can be enabled by setting bit 27 of the system control register (PCI offset 80h) to a 1b. This function is disabled by default.

## SPKROUT usage

The SPKROUT signal carries the digital audio signal from the PC Card to the system. When a 16-bit PC Card is configured for I/O mode, the BVD2 pin becomes  $\overline{SPKR}$ . This terminal, also used in CardBus applications, is referred to as CAUDIO.  $\overline{SPKR}$  passes a TTL level digital audio signal to the PCI4450. The CardBus CAUDIO signal also can pass a single amplitude, binary waveform. The binary audio signals from the two PC Card sockets are XOR'ed in the PCI4450 to produce SPKROUT. Figure 13 illustrates the SPKROUT connection.

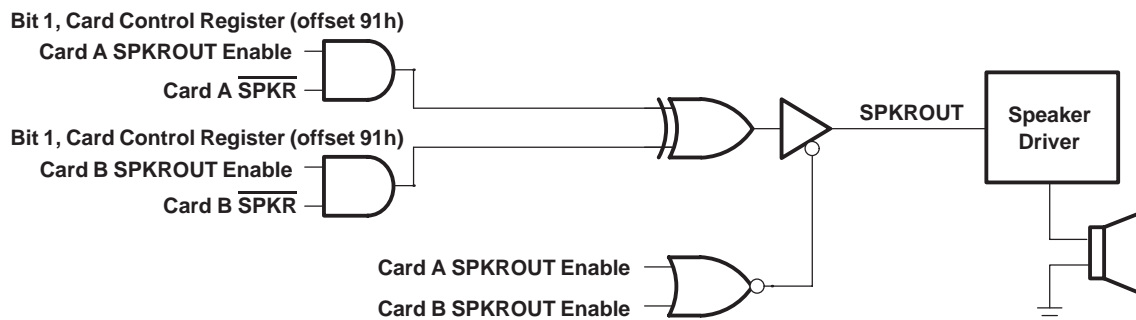

Figure 13. SPKROUT Connection to Speaker Driver



The SPKROUT signal is typically driven only by PC modem cards. To verify the SPKROUT on the PCI4450, a sample circuit was constructed, and this simplified schematic is provided below. The PCI1130/1131 required a pullup resistor on the SUSPEND/SPKROUT terminal. Since the PCI4450 does not multiplex any other function on SPKROUT, this terminal does not require a pullup resistor.

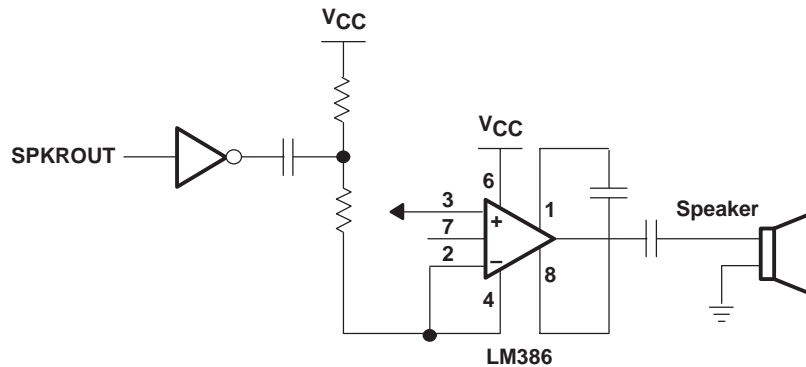

Figure 14. Simplified Test Schematic

### LED socket activity indicators

The socket activity LEDs indicate when an access is occurring to a PC Card. The LED signals are programmable via the MFUNC register. When configured for LED outputs, these terminals output an active high signal to indicate socket activity. LEDA1 indicates socket 0 (card A) activity, and LEDA2 indicates socket 1 (card B) activity.

The active-high LED signal is driven for 64 ms durations. When the LED is not being driven high, then it is driven to a low state. Either of the two circuits illustrated in Figure 15 can be implemented to provide the LED signaling, and it is left for the board designer to implement the circuit to best fit the application.

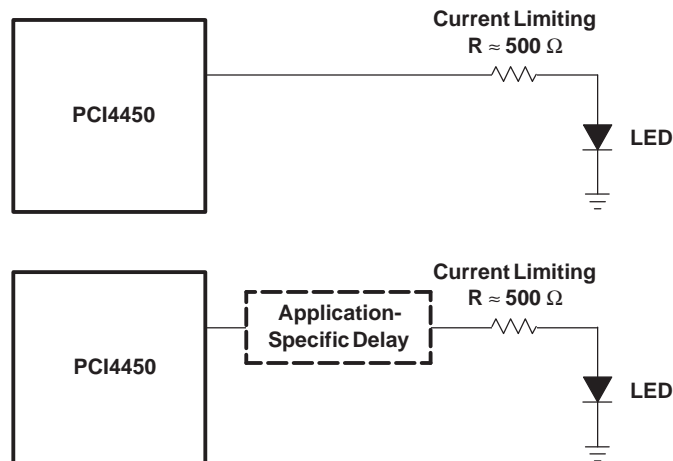

Figure 15. Two Sample LED Circuits

As indicated, the LED signals are driven for 64 ms, and this is accomplished by a counter circuit. To avoid the possibility of the LEDs appearing to be stuck when the PCI clock is stopped, the LED signaling is cut off when either the SUSPEND signal is asserted or when the PCI clock is to be stopped per the CLKRUN protocol.

Furthermore, if any additional socket activity occurs during this counter cycle, then the counter is reset and the LED signal remains driven. If socket activity is frequent (at least once every 64 ms), then the LED signals will remain driven.

# PCI4450 GFN/GJG PC Card and OHCI Controller

SCPS046 – JANUARY 1999

## PC Card 16 DMA support

The PCI4450 supports both PC/PCI (centralized) DMA and a distributed DMA slave engine for 16-bit PC Card DMA support. The distributed DMA (DDMA) slave register set provides the programmability necessary for the slave DDMA engine. Table 19 provides the DDMA register configuration.

**Table 19. Distributed DMA Registers**

TYPE	REGISTER NAME			DMA BASE ADDRESS OFFSET	
R	Reserved	Page	Current address		00h
W			Base address		
R	Reserved	Reserved	Current count		04h
W			Base count		
R	N/A	Reserved	N/A	Status	08h
W	Mode		Request	Command	
R	Multichannel	Reserved	N/A	Reserved	0Ch
W	Mask		Master Clear		

## CardBus socket register

The PCI4450 contains all registers for compatibility with the latest PCI to PCMCIA CardBus Bridge Specification. These registers exist as the CardBus socket registers, and are listed in Table 20.

**Table 20. CardBus Socket Registers**

REGISTER NAME	OFFSET
Socket event	00h
Socket mask	04h
Socket present state	08h
Socket force event	0Ch
Socket control	10h
Reserved	14h
Reserved	18h
Reserved	1Ch
Socket power management	20h



---

## programmable interrupt subsystem

Interrupts provide a way for I/O devices to let the microprocessor know that they require servicing. The dynamic nature of PC Cards, and the abundance of PC Card I/O applications require substantial interrupt support from the PCI4450. The PCI4450 provides several interrupt signaling schemes to accommodate the needs of a variety of platforms. The different mechanisms for dealing with interrupts in this device are based upon various specifications and industry standards. The ExCA register set provides interrupt control for some 16-bit PC Card functions, and the CardBus socket register set provides interrupt control for the CardBus PC Card functions. The PCI4450 is therefore backward compatible with existing interrupt control register definitions, and new registers have been defined where required.

The PCI4450 detects PC Card interrupts and events at the PC Card interface and notifies the host controller via one of several interrupt signaling protocols. To simplify the discussion of interrupts in the PCI4450, PC Card interrupts are classified as either card status change (CSC) or as functional interrupts.

The method by which any type of PCI4450 interrupt is communicated to the host interrupt controller varies from system to system. The PCI4450 offers system designers the choice of using parallel PCI interrupt signaling or the serialized ISA and/or PCI interrupt protocol. It is possible to use the parallel PCI interrupts in combination with serialized IRQs via the multifunction routing register at offset 8Ch.

## PC Card functional and card status change interrupts

PC Card functional interrupts are defined as requests from a PC Card application for interrupt service. They are indicated by asserting specially defined signals on the PC Card interface. Functional interrupts are generated by 16-bit I/O PC Cards and by CardBus PC Cards.

Card status change (CSC) type interrupts, defined as events at the PC Card interface which are detected by the PCI4450, may warrant notification of host card and socket services software for service. CSC events include both card insertion and removal from PC Card sockets, as well as transitions of certain PC Card signals.

Table 21 summarizes the sources of PC Card interrupts and the type of card associated with them. CSC and functional interrupt sources are dependent upon the type of card inserted in the PC Card socket. The three types of cards that may be inserted into any PC Card socket are: 16-bit memory card, 16-bit I/O card, and CardBus cards. Functional interrupt events are valid only for 16-bit I/O and CardBus cards, that is, the functional interrupts are not valid for 16-bit memory cards. Furthermore, card insertion and removal type CSC interrupts are independent of the card type.

**Table 21. PC Card Interrupt Events and Description**

Card Type	Event	Type	Signal	Description
16-bit Memory	Battery conditions (BVD1, BVD2)	CSC	BVD1 ( $\overline{\text{STSCHG}}$ ) // CSTSCHG	A transition on the BVD1 signal indicates a change in the PC Card battery conditions.
		CSC	BVD2 ( $\overline{\text{SPKR}}$ ) // CAUDIO	A transition on the BVD2 signal indicates a change in the PC Card battery conditions.
	Wait states (READY)	CSC	READY ( $\overline{\text{IREQ}}$ ) // $\overline{\text{CINT}}$	A transition on the READY signal indicates a change in the ability of the memory PC Card to accept or provide data.
16-bit I/O	Change in card status (STSCHG)	CSC	BVD1 ( $\overline{\text{STSCHG}}$ ) // CSTSCHG	The assertion of the $\overline{\text{STSCHG}}$ signal indicates a status change on the PC Card.
	Interrupt request (IREQ)	Functional	READY ( $\overline{\text{IREQ}}$ ) // $\overline{\text{CINT}}$	The assertion of the $\overline{\text{IREQ}}$ signal indicates an interrupt request from the PC Card.
CardBus	Change in card status (CSTSCHG)	CSC	BVD1 ( $\overline{\text{STSCHG}}$ ) // CSTSCHG	The assertion of the CSTSCHG signal indicates a status change on the PC Card.
	Interrupt request ( $\overline{\text{CINT}}$ )	Functional	READY ( $\overline{\text{IREQ}}$ ) // $\overline{\text{CINT}}$	The assertion of the $\overline{\text{CINT}}$ signal indicates an interrupt request from the PC Card.
	Power cycle complete	CSC	N/A	An interrupt is generated when a PC Card power-up cycle has completed.
All PC Cards	Card insertion or removal	CSC	CD1 // CCD1, CD2 // CCD2	A transition on either the $\overline{\text{CD1}}//\overline{\text{CCD1}}$ signal or the $\overline{\text{CD2}}//\overline{\text{CCD2}}$ signal indicates an insertion or removal of a 16-bit // CardBus PC Card.
	Power cycle complete	CSC	N/A	An interrupt is generated when a PC Card power-up cycle has completed.

The signal naming convention for PC Card signals describes the function for 16-bit memory and I/O cards, as well as CardBus. For example, the  $\overline{\text{READY}}(\overline{\text{IREQ}})//\overline{\text{CINT}}$  signal includes the READY signal for 16-bit memory cards, the  $\overline{\text{IREQ}}$  signal for 16-bit I/O cards, and the  $\overline{\text{CINT}}$  signal for CardBus cards. The 16-bit memory card signal name is first, with the I/O card signal name second enclosed in parentheses. The CardBus signal name follows after a forward double slash (/).

The PC Card standard describes the power-up sequence that must be followed by the PCI4450 when an insertion event occurs and the host requests that the socket  $V_{CC}$  and  $V_{PP}$  be powered. Upon completion of this power-up sequence, the PCI4450 interrupt scheme may be used to notify the host system, as in indicated in Table 21, denoted by the power cycle complete event. This interrupt source is considered a PCI4450 internal event because it does not depend on a signal change at the PC Card interface, but rather the completion of applying power to the socket.

**interrupt masks and flags**

Host software may individually mask, or disable, most of the potential interrupt sources listed in Table 22 by setting the appropriate bits in the PCI4450. By individually masking the interrupt sources listed in these tables, software can control which events will cause a PCI4450 interrupt. Host software has some control over which system interrupt the PCI4450 will assert by programming the appropriate routing registers. The PCI4450 allows host software to route PC Card CSC and PC Card functional interrupts to separate system interrupts. Interrupt routing is somewhat specific to the interrupt signaling method used. This will be discussed in more detail in the following sections.

When an interrupt is signaled by the PCI4450, the interrupt service routine must be able to discern which of the events in Table 22 caused the interrupt. Internal registers in the PCI4450 provide flags which report which of the interrupt sources was the cause of an interrupt. By reading these status bits, the interrupt service routine can determine which action is to be taken.



Table 22 details the registers and bits associated with masking and reporting potential interrupts. All interrupts may be masked except the functional PC Card interrupts, and an interrupt status flag is available for all types of interrupts.

**Table 22. PCI4450 Interrupt Masks and Flags Registers**

Card Type	Event	Mask	Flag
16-bit Memory	Battery conditions (BVD1, BVD2)	ExCA Offset 05h/45h/805h Bits 1 & 0	ExCA Offset 04h/44h/804h Bits 1 & 0
	Wait states (READY)	ExCA Offset 05h/45h/805h Bit 2	ExCA Offset 04h/44h/804h Bit 2
16-bit I/O	Change in card status (STSCHG)	ExCA Offset 05h/45h/805h Bit 0	ExCA Offset 04h/44h/804h Bit 0
	Interrupt request (IREQ)	Always enabled	PCI Configuration Offset 91h Bit 0
All 16-bit PC Cards	Power cycle complete	ExCA Offset 05h/45h/805h Bit 3	ExCA Offset 04h/44h/804h Bit 3
CardBus	Change in card status (CSTSCHG)	Socket mask register Bit 0	Socket event register Bit 0
	Interrupt request (CINT)	Always enabled	PCI Configuration Offset 91h Bit 0
	Power cycle complete	Socket mask register Bit 3	Socket event register Bit 3
	Card insertion or removal	Socket mask register Bits 2 & 1	Socket event register Bits 2 & 1

There is no mask bit to stop the PCI4450 from passing PC Card functional interrupts through to the appropriate interrupt scheme. Functional interrupts should not be fired until the PC Card is initialized and powered.

There are various methods of clearing the interrupt flag bits listed in Table 22. The flag bits in the ExCA registers (16-bit PC Card related interrupt flags) may be cleared by two different methods. One method is an explicit write of 1 to the flag bit to clear, and the other is a reading of the flag bit register. The selection of flag bit clearing is made by bit 2 in the global control register (ExCA offset 1Eh/5Eh/81Eh), and defaults to the flag cleared on read method.

The CardBus related interrupt flags can only be cleared by an explicit write of 1 to the interrupt flag in the socket event register. Although some of the functionality is shared between the CardBus registers and the ExCA registers, software should not program the chip through both register sets when a CardBus card is functioning.

### using parallel PCI interrupts

Parallel PCI interrupts are available when in pure parallel PCI interrupt mode and are routed on MFUNC0–MFUNC2. The PCI interrupt signaling is dependent upon the interrupt mode and is summarized in Table 23. The interrupt mode is selected in the device control register (92h).

**Table 23. Interrupt Pin Register Cross Reference**

Interrupt Signaling Mode	INTPIN Function 0	INTPIN Function 1
Parallel PCI interrupts only	0x01 ( $\overline{\text{INTA}}$ )	0x02 ( $\overline{\text{INTB}}$ )
Reserved	0x01 ( $\overline{\text{INTA}}$ )	0x02 ( $\overline{\text{INTB}}$ )
IRQ serialized (IRQSER) & parallel PCI interrupts	0x01 ( $\overline{\text{INTA}}$ )	0x01 ( $\overline{\text{INTA}}$ )
IRQ & PCI serialized (IRQSER) interrupts (default)	0x01 ( $\overline{\text{INTA}}$ )	0x02 ( $\overline{\text{INTB}}$ )

**power management overview**

In addition to the low-power CMOS technology process used for the PCI4450, various features are designed into the device to allow implementation of popular power saving techniques. These features and techniques are discussed in this section.

**CLKRUN protocol**

CLKRUN is the primary method of power management on the PCI bus side of the PCI4450. Since some chipsets do not implement CLKRUN, this is not always available to the system designer, and alternate power savings features are provided.

If CLKRUN is not implemented, then the CLKRUN pin should be tied low. CLKRUN is enabled by default via bit 1 (KEEPCLK) in the system control register (80h).

**CardBus PC Card power management**

The PCI4450 implements its own card power management engine that can turn off the CCLK to a socket when there is no activity to the CardBus PC Card. The CCLK can also be configured as divide by 16 instead of stopped. The CLKRUN protocol is followed on the CardBus interface to control this clock management.

**PCI bus power management**

The *PCI Bus Power Management Interface Specification* (PCIPM) establishes the infrastructure required to let the operating system control the power of PCI functions. This is done by defining a standard PCI interface and operations to manage the power of PCI functions on the bus. The PCI bus and the PCI functions can be assigned one of four software visible power management states, which result in varying levels of power savings.

The four power management states of PCI functions are: D0 - Fully On state, D1 and D2 - intermediate states, and D3 - Off state. Similarly, bus power states of the PCI bus are B0–B3. The bus power states B0–B3 are derived from the device power state of the upstream bridge device.

For the operating system to manage the device power states on the PCI bus, the PCI function should support four power management operations. The four operations are: capabilities reporting; power status reporting; setting the power state; and system wake-up. The operating system identifies the capabilities of the PCI function by traversing the new capabilities list. The presence of new capabilities is indicated by a 1b in bit 4 of the PCI status register (PCI offset 06h). When software determines that the device has a capabilities list by seeing that bit 4 of the PCI status register is set, it will read the capability pointer register at PCI offset 14h. This value in the register points the location in PCI configuration space of the capabilities linked list.

The first byte of each capability register block is required to be a unique ID of that capability. PCI power management has been assigned an ID of 01h. The next byte is a pointer to the next pointer item in the list of capabilities. If there are no more items in the list, then the next item pointer should be set to 0. The registers following the next item pointer are specific to the function’s capability. The PCIPM capability implements the following register block:

**Power Management Register Block**

Power management capabilities (PMC)		Next item pointer	Capability ID	Offset = 0
Data	PMCSR bridge support extensions	Power management control status (CSR)		Offset = 4

The power management capabilities (PMC) register is a static read-only register that provides information on the capabilities of the function, related to power management. The PMCSR register enables control of power management states and enables/monitors power management events. The data register is an optional register that provides a mechanism for state-dependent power measurements such as power consumed or heat dissipation.



## CardBus device class power management

The *PCI Bus Interface Specification for PCI-to-CardBus Bridges* was approved by PCMCIA in December of 1997. This specification follows the device and bus state definitions provided in the *PCI Bus Power Management Interface Specification* published by the PCI Special Interest Group (SIG). The main issue addressed in the *PCI Bus Interface Specification for PCI-to-CardBus Bridges* is wake-up from D3<sub>hot</sub> or D3<sub>cold</sub> without losing wake-up context (also called  $\overline{\text{PME}}$  context).

The specific issues addressed by the *PCI Bus Interface Specification for PCI-to-CardBus Bridges* for D3 wake up are as follows:

- Preservation of device context: The *PCI Power Management Specification* version 1.0 states that  $\overline{\text{PRST}}$  must be asserted when transitioning from D3<sub>cold</sub> to D0. Some method to preserve wake-up context must be implemented so that  $\overline{\text{PRST}}$  does not clear the  $\overline{\text{PME}}$  context registers.
- Power source in D3<sub>cold</sub> if wake-up support is required from this state.

The Texas Instruments PCI4450 addresses these D3 wake-up issues in the following manner:

- Preservation of device context: When  $\overline{\text{PRST}}$  is asserted, bits required to preserve  $\overline{\text{PME}}$  context are not cleared. To clear all bits in the PCI4450, another reset pin is defined:  $\overline{\text{G\_RST}}$  (global reset).  $\overline{\text{G\_RST}}$  is normally only asserted during the initial power-on sequence. After the initial boot,  $\overline{\text{PRST}}$  should be asserted so that  $\overline{\text{PME}}$  context is retained for D3-to-D0 transitions. Bits cleared by  $\overline{\text{G\_RST}}$ , but not cleared by  $\overline{\text{PRST}}$  (if the  $\overline{\text{PME}}$  enable bit is set), are referred to as  $\overline{\text{PME}}$  context bits. Please refer to the master list of  $\overline{\text{PME}}$  context bits in the next section.
- Power source in D3<sub>cold</sub> if wake-up support is required from this state. Since  $V_{\text{CC}}$  is removed in D3<sub>cold</sub>, an auxiliary power source must be switched to the PCI4450  $V_{\text{CC}}$  pins. This switch should be a *make before break* type of switch, so that  $V_{\text{CC}}$  to the PCI4450 is not interrupted.

### master list of $\overline{\text{PME}}$ context bits and global reset only bits

$\overline{\text{PME}}$  context bit means that the bit is cleared only by the assertion of  $\overline{\text{G\_RST}}$  when the  $\overline{\text{PME}}$  enable bit is set (PCI offset A4h, bit 8). If  $\overline{\text{PME}}$  is not enabled, then these bits are cleared when either  $\overline{\text{PRST}}$  or  $\overline{\text{G\_RST}}$  is asserted.

Global reset only bits, as the name implies, are only cleared by  $\overline{\text{G\_RST}}$ . These bits are never cleared by  $\overline{\text{PRST}}$  regardless of the setting of the  $\overline{\text{PME}}$  enable bit. (PCI offset A4h, bit 8). The  $\overline{\text{G\_RST}}$  signal is gated only by the  $\overline{\text{SUSPEND}}$  signal. This means that assertion of  $\overline{\text{SUSPEND}}$  blocks the  $\overline{\text{G\_RST}}$  signal internally, thus preserving all register contents.

# PCI4450 GFN/GJG

## PC Card and OHCI Controller

SCPS046 – JANUARY 1999

---

### Global reset only bits:

- Subsystem ID/subsystem vendor ID (PCI offset 40h): bits 31–0
- PC Card 16-bit legacy mode base address register (PCI offset 44h): bits 31–1
- System control register (PCI offset 80h): bits 31–29, 27–24, 22–14, 6–3, 1, 0
- Multimedia control register (PCI offset 84h): bits 7–0
- General status register (PCI offset 85h): bits 2–0
- General-purpose event status register (PCI offset 88h): bits 7, 6, 3–0
- General-purpose event enable register (PCI offset 89h): bits 7, 6, 3–0
- General-purpose input register (PCI offset 8Ah): bits 3–0
- General-purpose output register (PCI offset 8Bh): bits 3–0
- MFUNC routing register (PCI offset 8Ch): bits 31–0
- Retry status register (PCI offset 90h): bits 7–1
- Card control register (PCI offset 91h): bits 7, 6, 2, 1, 0
- Device control register (PCI offset 92h): bits 7–0
- Diagnostic register (PCI offset 93h): bits 7–0
- Socket DMA register 0 (PCI offset 94h): bits 1–0
- Socket DMA register 1 (PCI offset 98h): bits 15–0
- $\overline{\text{GPE}}$  control/status register (PCI offset A8h): bits 10, 9, 8, 2, 1, 0

### $\overline{\text{PME}}$ context bits

- Bridge control register (PCI offset 3Eh): bit 6
- Power management capabilities register (PCI offset A2h): bit 15
- Power management control/status register (PCI offset A4h): bits 15, 8
- ExCA power control register (ExCA 802h/842h): bits 7, 4, 3, 1, 0
- ExCA interrupt and general control (ExCA 803h/843h): bit 6, 5
- ExCA card status change register (ExCA 804h/844h): bits 3–0
- ExCA card status change interrupt register (ExCA 805h/845h): bits 3–0
- CardBus socket event register (CardBus offset 00h): bits 3–0
- CardBus socket mask register (CardBus offset 04h): bits 3–0
- CardBus socket control register (CardBus offset 10h): bits 6, 5, 4, 2, 1, 0



system diagram implementing CardBus device class power management

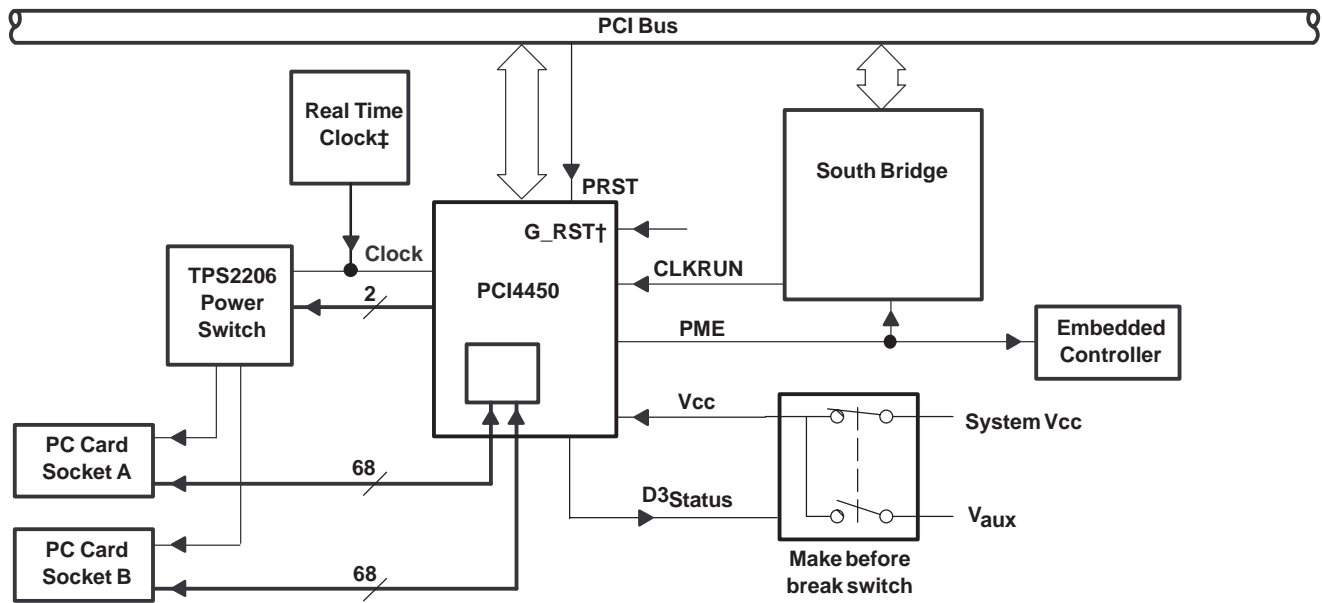

† The system connection to  $\overline{G\_RST}$  is implementation specific.  $\overline{G\_RST}$  should be applied whenever  $V_{CC}$  is applied to the PCI4450.  $\overline{PRST}$  should be applied for subsequent warm resets.  
‡ Not required if internal oscillator is used.

Figure 16. System Diagram Implementing CardBus Device Class Power Management

suspend mode

The  $\overline{SUSPEND}$  signal, provided for backward compatibility, gates the  $\overline{PRST}$  (PCI reset) signal and the  $\overline{G\_RST}$  (global reset) signal from the PCI4450. Besides gating  $\overline{PRST}$  and  $\overline{G\_RST}$ ,  $\overline{SUSPEND}$  also gates PCLK inside the PCI4450 in order to minimize power consumption.

Gating PCLK does not create any issues with respect to the power switch interface in the PCI4450. This is because the PCI4450 does not depend on the PCI clock to clock the power switch interface. There are two methods to clock the power switch interface in the PCI4450:

- Use an external clock to the PCI4450 CLOCK pin
- Use the internal oscillator

It should also be noted that asynchronous signals, such as card status change interrupts and RI\_OUT, can be passed to the host system without a PCI clock. However, if card status change interrupts are routed over the serial interrupt stream, then the PCI clock will have to be restarted in order to pass the interrupt, because neither the internal oscillator nor an external clock is routed to the serial interrupt state machine.

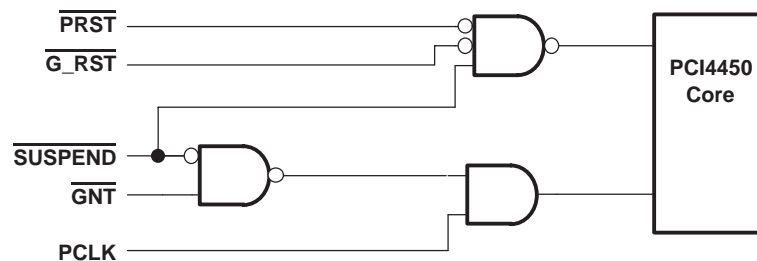

Figure 17.  $\overline{SUSPEND}$  Functional Illustration

**requirements for  $\overline{\text{SUSPEND}}$**

A requirement for implementing suspend mode is that the PCI bus must not be parked on the PCI4450 when  $\overline{\text{SUSPEND}}$  is asserted. The PCI4450 responds to  $\overline{\text{SUSPEND}}$  being asserted by placing the REQ pin in a high impedance state. The PCI4450 will also gate the internal clock and reset.

The GPIOs, MFUNC signals, and  $\overline{\text{RI\_OUT}}$  signals are all active during  $\overline{\text{SUSPEND}}$ , unless they are disabled in the appropriate PCI4450 registers.

**ring indicate**

The  $\overline{\text{RI\_OUT}}$  output is an important feature used in legacy power management. It is used so that a system can go into a suspended mode and wake up on modem rings and other card events. The  $\overline{\text{RI\_OUT}}$  signal on the PCI4450 may be asserted under any of the following conditions:

- A 16-bit PC Card modem in a powered socket asserts  $\overline{\text{RI}}$  to indicate an incoming call to the system.
- A powered down CardBus card asserts CSTSCHG (CBWAKE) requesting system and interface wake up.
- A card status change (CSC) event, such as insertion/removal of cards, battery voltage levels, occurs.

A CSTSCHG signal from a powered CardBus card is indicated as a CSC event, not as a CBWAKE event. These two  $\overline{\text{RI\_OUT}}$  events are enabled separately. The following figure details various enable bits for the PCI4450  $\overline{\text{RI\_OUT}}$  function; however, it does not illustrate the masking of CSC events. See *interrupt masks and flags* for a detailed description of CSC interrupt masks and flags.

$\overline{\text{RI\_OUT}}$  is multiplexed on the same pin with  $\overline{\text{PME}}$ . The default is for  $\overline{\text{RI\_OUT}}$  to be signaled on this pin. In PCI power managed systems, the  $\overline{\text{PME}}$  signal should be enabled by setting bit 0 ( $\overline{\text{RI\_OUT/PME}}$ ) in the system control register (80h) and clearing bit 7 (RIENB) in the card control register (91h).

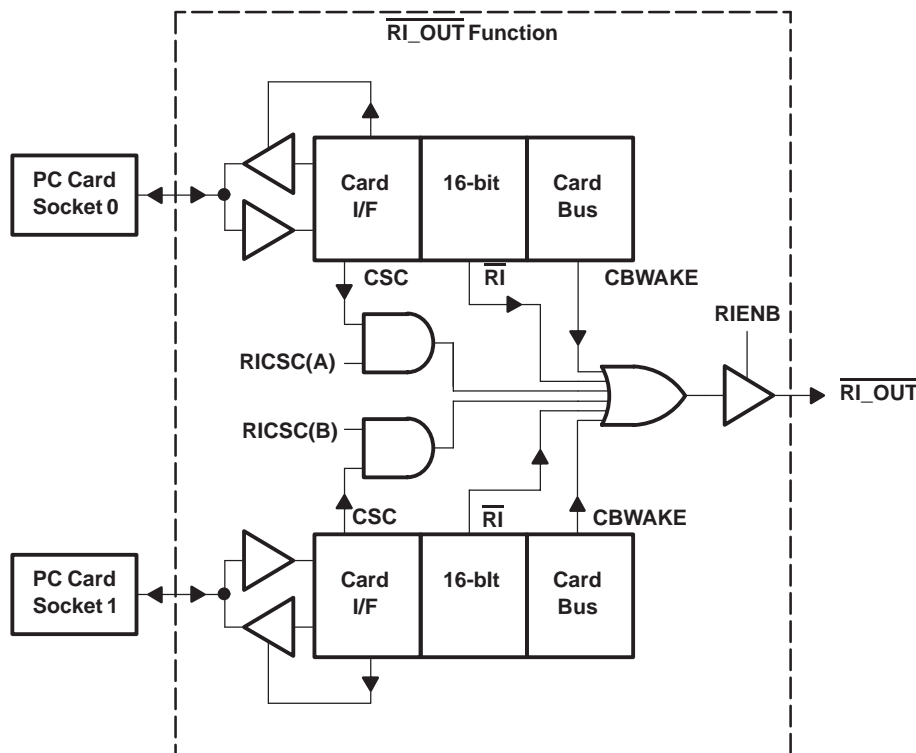

**Figure 18.  $\overline{\text{RI\_OUT}}$  Functional Illustration**

Routing of CSC events to the  $\overline{\text{RI\_OUT}}$  signal, enabled on a per socket basis, is programmed by the RICSC bit in the card control register. This bit is socket dependent (not shared), as illustrated in Figure 18.

The  $\overline{RI}$  signal from the 16-bit PC Card interface is masked by the ExCA control bit RINGEN in the ExCA interrupt and general control register. This is programmed on a per socket basis, and is only applicable when a 16-bit card is powered in the socket.

The CBWAKE signaling to  $\overline{RI\_OUT}$  is enabled through the same mask as the CSC event for CSTSCHG. The mask bit, CSTSMASK, is programmed through the socket mask register in the CardBus socket registers.

### PC CARD CONTROLLER PROGRAMMING MODEL

This section describes the PCI4450 PCI configuration registers that make up the 256-byte PCI configuration header for each PCI4450 function. As noted below, some bits are global in nature and should be accessed only through function 0.

Registers containing one or more global bits are denoted by a “§.”

Any bit followed by a “†” is not cleared by the assertion of  $\overline{PRST}$  (refer to *CardBus device class power management* for more details) if  $\overline{PME}$  is enabled (PCI offset A4h, bit 8). In this case, these bits are only cleared by  $\overline{G\_RST}$ . If  $\overline{PME}$  is not enabled, then these bits are cleared by  $\overline{G\_RST}$  or  $\overline{PRST}$ . These bits are sometimes referred to as PME context bits and are implemented to allow  $\overline{PME}$  context to be preserved when transitioning from D3<sub>hot</sub> or D3<sub>cold</sub> to D0. If the PME context  $\overline{PRST}$  functionality is not desired, then the  $\overline{PRST}$  and  $\overline{G\_RST}$  signals should be tied together.

If a bit is followed by a “‡”, then this bit is only cleared by  $\overline{G\_RST}$  in all cases (not conditional on  $\overline{PME}$  being enabled). These bits are intended to maintain device context such as interrupt routing and MFUNC programming during “warm” resets.

#### PCI configuration registers (functions 0 and 1)

The PCI4450 is a multifunction PCI device, and the PC Card controller is integrated as PCI functions 0 and 1. The configuration header, compliant with the PCI Specification as a CardBus bridge header, is PC97/PC98 compliant as well. Table 24 illustrates the PCI configuration header, which includes both the predefined portion of the configuration space and the user definable registers.

# PCI4450 GFN/GJG PC Card and OHCI Controller

SCPS046 – JANUARY 1999

**Table 24. Functions 0 and 1 PCI Configuration Register Map**

REGISTER NAME				OFFSET
Device ID		Vendor ID		00h
Status		Command		04h
Class code			Revision ID	08h
BIST	Header type	Latency timer	Cache line size	0Ch
CardBus socket registers/ExCA base address				10h
Secondary status		Reserved	Capability pointer	14h
CardBus latency timer	Subordinate bus number	CardBus bus number	PCI bus number	18h
CardBus memory base register 0				1Ch
CardBus memory limit register 0				20h
CardBus memory base register 1				24h
CardBus memory limit register 1				28h
CardBus I/O base register 0				2Ch
CardBus I/O limit register 0				30h
CardBus I/O base register 1				34h
CardBus I/O limit register 1				38h
Bridge control †		Interrupt pin	Interrupt line	3Ch
Subsystem ID ‡		Subsystem vendor ID ‡		40h
PC Card 16-bit I/F legacy mode base address ‡				44h
Reserved				48h–7Fh
System control ‡				80h
Reserved	Reserved	General status †	Multimedia control ‡	84h
GP0 control ‡	GP1 control ‡	GPE enable ‡	GPE status ‡	88h
Multifunction routing †				8Ch
Diagnostics ‡	Device control ‡	Card control ‡	Retry status ‡	90h
Socket DMA register 0 ‡				94h
Socket DMA register 1 ‡				98h
Reserved				9Ch
Power management capabilities †		Next pointer item	Capability ID	A0h
Data (Reserved)	PMCSR bridge support extensions	Power management control/status †		A4h
Reserved		GPE control/status ‡		A8h

† One or more bits in the register are PME context bits and can only be cleared by the assertion of  $\overline{G\_RST}$  when  $\overline{PME}$  is enabled. If  $\overline{PME}$  is not enabled, then these bits are cleared by the assertion of  $\overline{PRST}$  or  $\overline{G\_RST}$ .

‡ One or more bits in this register are only cleared by the assertion  $\overline{G\_RST}$ .



**vendor ID register**

<b>Bit</b>	15	14	13	12	11	10	9	8	7	6	5	4	3	2	1	0
<b>Name</b>	Vendor ID															
<b>Type</b>	R	R	R	R	R	R	R	R	R	R	R	R	R	R	R	R
<b>Default</b>	0	0	0	1	0	0	0	0	0	1	0	0	1	1	0	0

Register: **Vendor ID**  
 Type: Read-only  
 Offset: 00h (Functions 0, 1)  
 Default: 104Ch  
 Description: This 16-bit register contains a value allocated by the PCI SIG that identifies the manufacturer of the PCI device. The vendor ID assigned to Texas Instruments is 104Ch.

**device ID register**

<b>Bit</b>	15	14	13	12	11	10	9	8	7	6	5	4	3	2	1	0
<b>Name</b>	Device ID															
<b>Type</b>	R	R	R	R	R	R	R	R	R	R	R	R	R	R	R	R
<b>Default</b>	1	0	1	0	1	1	0	0	0	1	0	0	0	0	0	0

Register: **Device ID**  
 Type: Read-only  
 Offset: 02h (Functions 0, 1)  
 Default: AC40h  
 Description: This 16-bit register contains a value assigned to the PCI4450 by Texas Instruments. The device identification for the PCI4450 is AC40.



# PCI4450 GFN/GJG PC Card and OHCI Controller

SCPS046 – JANUARY 1999

## command register

Bit	15	14	13	12	11	10	9	8	7	6	5	4	3	2	1	0
Name	Command															
Type	R	R	R	R	R	R	R	R/W	R	R/W	R/W	R	R	R/W	R/W	R/W
Default	0	0	0	0	0	0	0	0	0	0	0	0	0	0	0	0

Register: **Command**

Type: Read-only, Read/Write

Offset: 04h

Default: 0000h

Description: The command register provides control over the PCI4450 interface to the PCI bus. All bit functions adhere to the definitions in the PCI Local Bus Specification, see Table 25. None of the bit functions in this register are shared between the two PCI4450 PCI functions. Two command registers exist in the PCI4450, one for each function. Software manipulates the two PCI4450 functions as separate entities when enabling functionality through the command register. The SERR\_EN and PERR\_EN enable bits in this register are internally wired OR between the two functions, and these control bits appear separate per function to software.

**Table 25. PCI Command Register Description**

BIT	TYPE	FUNCTION
15–10	R	Reserved. These bits return 0s when read. Writes have no effect.
9	R	Fast back-to-back enable. The PCI4450 will not generate fast back-to-back transactions; therefore, this bit is read-only. This bit returns a 0 when read.
8	R/W	System error ( $\overline{\text{SERR}}$ ) enable. This bit controls the enable for the $\overline{\text{SERR}}$ driver on the PCI interface. $\overline{\text{SERR}}$ can be asserted after detecting an address parity error on the PCI bus. Both this bit and bit 6 must be set for the PCI4450 to report address parity errors. 0 = Disables the $\overline{\text{SERR}}$ output driver (default). 1 = Enables the $\overline{\text{SERR}}$ output driver.
7	R	Address/datastepping control. The PCI4450 does not support address/data stepping, and this bit is hardwired to 0. Writes to this bit have no effect.
6	R/W	Parity error response enable. This bit controls the PCI4450's response to parity errors through the $\overline{\text{PERR}}$ signal. Data parity errors are indicated by asserting $\overline{\text{PERR}}$ , while address parity errors are indicated by asserting $\overline{\text{SERR}}$ . 0 = PCI4450 ignores detected parity error (default). 1 = PCI4450 responds to detected parity errors.
5	R/W	VGA palette snoop. When set to 1, palette snooping is enabled (i.e., the PCI4450 does not respond to palette register writes and snoops the data). When the bit is 0, the PCI4450 will treat all palette accesses like all other accesses.
4	R	Memory write and invalidate enable. This bit controls whether a PCI initiator device can generate memory write and invalidate commands. The PCI4450 controller does not support memory write and invalidate commands, it uses memory write commands instead; therefore, this bit is hardwired to 0. This bit returns 0 when read. Writes to this bit have no effect.
3	R	Special cycles. This bit controls whether or not a PCI device ignores PCI special cycles. The PCI4450 does not respond to special cycle operations; therefore, this bit is hardwired to 0. This bit returns 0 when read. Writes to this bit have no effect.
2	R/W	Bus master control. This bit controls whether or not the PCI4450 can act as a PCI bus initiator (master). The PCI4450 can take control of the PCI bus only when this bit is set. 0 = Disables the PCI4450's ability to generate PCI bus accesses (default). 1 = Enables the PCI4450's ability to generate PCI bus accesses.
1	R/W	Memory space enable. This bit controls whether or not the PCI4450 may claim cycles in PCI memory space. 0 = Disables the PCI4450's response to memory space accesses (default). 1 = Enables the PCI4450's response to memory space accesses.
0	R/W	I/O space control. This bit controls whether or not the PCI4450 may claim cycles in PCI I/O space. 0 = Disables the PCI4450 from responding to I/O space accesses (default). 1 = Enables the PCI4450 to respond to I/O space accesses.



**status register**

Bit	15	14	13	12	11	10	9	8	7	6	5	4	3	2	1	0
Name	Status															
Type	R/W	R/W	R/W	R/W	R/W	R	R	R/W	R	R	R	R	R	R	R	R
Default	0	0	0	0	0	0	1	0	0	0	0	1	0	0	0	0

Register: **Status**

Type: Read-only, Read/Write

Offset: 06h (Functions 0, 1)

Default: 0210h

Description: The status register provides device information to the host system. Bits in this register may be read normally. A bit in the status register is reset when a 1 is written to that bit location; a 0 written to a bit location has no effect. All bit functions adhere to the definitions in the PCI Bus Specification, as seen in the bit descriptions. PCI bus status is shown through each function.

**Table 26. Status Register Description**

BIT	TYPE	FUNCTION
15	R/W	PAR_ERR. Detected parity error. This bit is set when a parity error is detected, either address or data parity errors. Write a 1 to clear this bit.
14	R/W	SYS_ERR. Signaled system error. This bit is set when <u>SERR</u> is enabled and the PCI4450 signaled a system error to the host. Write a 1 to clear this bit.
13	R/W	MABORT. Received master abort. This bit is set when a cycle initiated by the PCI4450 on the PCI bus has been terminated by a master abort. Write a 1 to clear this bit.
12	R/W	TABT_REC. Received target abort. This bit is set when a cycle initiated by the PCI4450 on the PCI bus was terminated by a target abort. Write a 1 to clear this bit.
11	R/W	TABT_SIG. Signaled target abort. This bit is set by the PCI4450 when it terminates a transaction on the PCI bus with a target abort. Write a 1 to clear this bit.
10–9	R	PCI_SPEED. DEVSEL timing. These bits encode the timing of <u>DEVSEL</u> and are hardwired to 01b indicating that the PCI4450 asserts this signal at a medium speed on nonconfiguration cycle accesses.
8	R/W	DATAPAR. Data parity error detected. Write a 1 to clear this bit. 0 = The conditions for setting this bit have not been met. 1 = A data parity error occurred and the following conditions were met: a. PERR was asserted by any PCI device including the PCI4450. b. The PCI4450 was the bus master during the data parity error. c. The parity error response bit is set in the command register.
7	R	FBB_CAP. Fast back-to-back capable. The PCI4450 cannot accept fast back-to-back transactions; thus, this bit is hardwired to 0.
6	R	UDF. UDF supported. The PCI4450 does not support the user definable features; therefore, this bit is hardwired to 0.
5	R	66 MHz capable. The PCI4450 operates at a maximum PCLK frequency of 33 MHz; therefore, this bit is hardwired to 0.
4	R	Capabilitieslist. This bit returns 1 when read. This bit indicates that capabilities in addition to standard PCI capabilities are implemented. The linked list of PCI power management capabilities is implemented in this function.
3–0	R	Reserved. These bits return 0s when read.

# PCI4450 GFN/GJG PC Card and OHCI Controller

SCPS046 – JANUARY 1999

## class code and revision ID register

Bit	31	30	29	28	27	26	25	24	23	22	21	20	19	18	17	16
<b>Name</b>	Class code and revision ID															
<b>Type</b>	R	R	R	R	R	R	R	R	R	R	R	R	R	R	R	R
<b>Default</b>	0	0	0	0	0	1	1	0	0	0	0	0	0	1	1	1
Bit	15	14	13	12	11	10	9	8	7	6	5	4	3	2	1	0
<b>Name</b>	Class code and revision ID															
<b>Type</b>	R	R	R	R	R	R	R	R	R	R	R	R	R	R	R	R
<b>Default</b>	0	0	0	0	0	0	0	0	0	0	0	0	0	0	0	0

Register: **Class code and revision ID**

Type: Read-only

Offset: 08h (Functions 0, 1)

Default: 0607 0000h

Description: This register recognizes the PCI4450 functions 0 and 1 as a bridge device (06h) and CardBus bridge device (07h) with a 00h programming interface. Furthermore, the TI chip revision is indicated in the lower byte (00h).

## cache line size register

Bit	7	6	5	4	3	2	1	0
<b>Name</b>	Cache line size							
<b>Type</b>	R/W	R/W	R/W	R/W	R/W	R/W	R/W	R/W
<b>Default</b>	0	0	0	0	0	0	0	0

Register: **Cache line size**

Type: Read/Write

Offset: 0Ch (Functions 0, 1)

Default: 00h

Description: This register is programmed by host software to indicate the system cache line size.





**latency timer register**

Bit	7	6	5	4	3	2	1	0
Name	Latency timer							
Type	R/W	R/W	R/W	R/W	R/W	R/W	R/W	R/W
Default	0	0	0	0	0	0	0	0

Register: **Latency timer**

Type: Read/Write

Offset: 0Dh

Default: 00h

Description: This register specifies the latency timer for the PCI4450, in units of PCI clock cycles. When the PCI4450 is a PCI bus initiator and asserts  $\overline{\text{FRAME}}$ , the latency timer begins counting from zero. If the latency timer expires before the PCI4450 transaction has terminated, then the PCI4450 terminates the transaction when its  $\overline{\text{GNT}}$  is deasserted.

**header type register**

Bit	7	6	5	4	3	2	1	0
Name	Header type							
Type	R	R	R	R	R	R	R	R
Default	1	0	0	0	0	0	1	0

Register: **Header type**

Type: Read-only

Offset: 0Eh (Functions 0, 1)

Default: 82h

Description: This register returns 82h when read, indicating that the PCI4450 functions 0 and 1 configuration spaces adhere to the CardBus bridge PCI header. The CardBus bridge PCI header ranges from PCI register 0 to 7Fh, and 80h–FFh is user definable extension registers.

**BIST register**

Bit	7	6	5	4	3	2	1	0
Name	BIST							
Type	R	R	R	R	R	R	R	R
Default	0	0	0	0	0	0	0	0

Register: **BIST**

Type: Read-only

Offset: 0Fh (Functions 0, 1)

Default: 00h

Description: Since the PCI4450 does not support a built-in self-test (BIST), this register returns the value of 00h when read. This register returns 0s for the two PCI4450 functions.

# PCI4450 GFN/GJG PC Card and OHCI Controller

SCPS046 – JANUARY 1999

## CardBus socket registers / ExCA registers base address register

Bit	31	30	29	28	27	26	25	24	23	22	21	20	19	18	17	16
<b>Name</b>	CardBus socket registers/ExCA base address															
<b>Type</b>	R/W	R/W	R/W	R/W	R/W	R/W	R/W	R/W	R/W	R/W	R/W	R/W	R/W	R/W	R/W	R/W
<b>Default</b>	0	0	0	0	0	0	0	0	0	0	0	0	0	0	0	0
Bit	15	14	13	12	11	10	9	8	7	6	5	4	3	2	1	0
<b>Name</b>	CardBus socket registers/ExCA base address															
<b>Type</b>	R/W	R/W	R/W	R/W	R	R	R	R	R	R	R	R	R	R	R	R
<b>Default</b>	0	0	0	0	0	0	0	0	0	0	0	0	0	0	0	0

Register: **CardBus socket registers/ExCA base address**

Type: Read-only, Read/Write

Offset: 10h

Default: 0000 0000h

Description: This register is programmed with a base address referencing the CardBus socket registers and the memory mapped ExCA register set. Bits 31–12 are read/write, and allow the base address to be located anywhere in the 32-bit PCI memory address space on a 4-Kbyte boundary. Bits 11–0 are read-only, returning 0s when read. When software writes all ones to this register, the value read back will be FFFF F000h, indicating that at least 4K bytes of memory address space are required. The CardBus registers start at offset 000h, and the memory mapped ExCA registers begin at offset 800h. This register is not shared by functions 0 and 1, mapping each socket control register separately.

## capability pointer register

Bit	7	6	5	4	3	2	1	0
<b>Name</b>	Capabilitypointer							
<b>Type</b>	R	R	R	R	R	R	R	R
<b>Default</b>	1	0	1	0	0	0	0	0

Register: **Capability pointer**

Type: Read-only

Offset: 14h

Default: A0h

Description: This register provides a pointer into the PCI configuration header where the PCI power management register block resides. PCI header doublewords at A0h and A4h provide the power management (PM) registers. Each socket has its own capability pointer register. This register is read-only and returns A0h when read.



**secondary status register**

Bit	15	14	13	12	11	10	9	8	7	6	5	4	3	2	1	0
Name	Secondary status															
Type	R/WC	R/WC	R/WC	R/WC	R/WC	R	R	R/WC	R	R	R	R	R	R	R	R
Default	0	0	0	0	0	0	1	0	0	0	0	0	0	0	0	0

Register: **Secondary status**

Type: Read-only, Read/Write to Clear

Offset: 16h

Default: 0200h

Description: This register is compatible with the PCI-PCI bridge secondary status register. It indicates CardBus related device information to the host system. This register is very similar to the PCI status register (offset 06h), and status bits are cleared by a writing a 1. This register is not shared by the two socket functions, but is accessed on a per socket basis.

**Table 27. Secondary Status Register Description**

BIT	TYPE	FUNCTION
15	R/WC	CBPARITY. Detected parity error. This bit is set when a CardBus parity error is detected, either address or data parity errors. Write a 1 to clear this bit.
14	R/WC	CBSERR. Signaled system error. This bit is set when $\overline{\text{CSERR}}$ is signaled by a CardBus card. The PCI4450 does not assert the $\overline{\text{CSERR}}$ signal. Write a 1 to clear this bit.
13	R/WC	CBMABORT. Received master abort. This bit is set when a cycle initiated by the PCI4450 on the CardBus bus has been terminated by a master abort. Write a 1 to clear this bit.
12	R/WC	REC_CBTA. Received target abort. This bit is set when a cycle initiated by the PCI4450 on the CardBus bus was terminated by a target abort. Write a 1 to clear this bit.
11	R/WC	SIG_CBTA. Signaled target abort. This bit is set by the PCI4450 when it terminates a transaction on the CardBus bus with a target abort. Write a 1 to clear this bit.
10–9	R	CB_SPEED. CDEVSEL timing. These bits encode the timing of $\overline{\text{CDEVSEL}}$ and are hardwired to 01b indicating that the PCI4450 asserts this signal at a medium speed.
8	R/WC	CB_DPAR. CardBus data parity error detected. Write a 1 to clear this bit. 0 = The conditions for setting this bit have not been met. 1 = A data parity error occurred and the following conditions were met: a. CPERR was asserted on the CardBus interface. b. The PCI4450 was the bus master during the data parity error. c. The parity error response bit is set in the bridge control register.
7	R	CBFBB_CAP. Fast back-to-back capable. The PCI4450 cannot accept fast back-to-back transactions; therefore, this bit is hardwired to 0.
6	R	CB_UDF. User definable feature support. The PCI4450 does not support the user definable features; therefore, this bit is hardwired to 0.
5	R	CB66MHZ. 66 MHz capable. The PCI4450 CardBus interface operates at a maximum CCLK frequency of 33 MHz; therefore, this bit is hardwired to 0.
4–0	R	Reserved. These bits return 0s when read.

# PCI4450 GFN/GJG PC Card and OHCI Controller

SCPS046 – JANUARY 1999

## PCI bus number register

Bit	7	6	5	4	3	2	1	0
Name	PCI bus number							
Type	R/W	R/W	R/W	R/W	R/W	R/W	R/W	R/W
Default	0	0	0	0	0	0	0	0

Register: **PCI bus number**  
 Type: Read/Write  
 Offset: 18h (Functions 0, 1)  
 Default: 00h  
 Description: This register is programmed by the host system to indicate the bus number of the PCI bus to which the PCI4450 is connected. The PCI4450 uses this register, in conjunction with the CardBus bus number and subordinate bus number registers, to determine when to forward PCI configuration cycles to its secondary buses.

## CardBus bus number register

Bit	7	6	5	4	3	2	1	0
Name	CardBus bus number							
Type	R/W	R/W	R/W	R/W	R/W	R/W	R/W	R/W
Default	0	0	0	0	0	0	0	0

Register: **CardBus bus number**  
 Type: Read/Write  
 Offset: 19h  
 Default: 00h  
 Description: This register is programmed by the host system to indicate the bus number of the CardBus bus to which the PCI4450 is connected. The PCI4450 uses this register, in conjunction with the PCI bus number and subordinate bus number registers, to determine when to forward PCI configuration cycles to its secondary buses. This register is separate for each PCI4450 controller function.

## subordinate bus number register

Bit	7	6	5	4	3	2	1	0
Name	Subordinate bus number							
Type	R/W	R/W	R/W	R/W	R/W	R/W	R/W	R/W
Default	0	0	0	0	0	0	0	0

Register: **Subordinate bus number**  
 Type: Read/Write  
 Offset: 1Ah  
 Default: 00h  
 Description: This register is programmed by the host system to indicate the highest numbered bus below the CardBus bus. The PCI4450 uses this register, in conjunction with the PCI bus number and CardBus bus number registers, to determine when to forward PCI configuration cycles to its secondary buses. This register is separate for each CardBus controller function.



**CardBus latency timer register**

Bit	7	6	5	4	3	2	1	0
Name	CardBus latency timer							
Type	R/W	R/W	R/W	R/W	R/W	R/W	R/W	R/W
Default	0	0	0	0	0	0	0	0

Register: **CardBus latency timer**

Type: Read/Write

Offset: 1Bh (Functions 0, 1)

Default: 00h

Description: This register is programmed by the host system to specify the latency timer for the PCI4450 CardBus interface, in units of CCLK cycles. When the PCI4450 is a CardBus initiator and asserts  $\overline{\text{CFRAME}}$ , the CardBus latency timer begins counting. If the latency timer expires before the PCI4450 transaction has terminated, then the PCI4450 terminates the transaction at the end of the next data phase. A recommended minimum value for this register of 20h allows most transactions to be completed.

**memory base registers 0, 1**

Bit	31	30	29	28	27	26	25	24	23	22	21	20	19	18	17	16
Name	Memory base registers 0, 1															
Type	R/W	R/W	R/W	R/W	R/W	R/W	R/W	R/W	R/W	R/W	R/W	R/W	R/W	R/W	R/W	R/W
Default	0	0	0	0	0	0	0	0	0	0	0	0	0	0	0	0
Bit	15	14	13	12	11	10	9	8	7	6	5	4	3	2	1	0
Name	Memory base registers 0, 1															
Type	R/W	R/W	R/W	R/W	R	R	R	R	R	R	R	R	R	R	R	R
Default	0	0	0	0	0	0	0	0	0	0	0	0	0	0	0	0

Register: **Memory base registers 0, 1**

Type: Read-only, Read/Write

Offset: 1Ch, 24h

Default: 0000 0000h

Description: These registers indicate the lower address of a PCI memory address range. They are used by the PCI4450 to determine when to forward a memory transaction to the CardBus bus, and likewise, when to forward a CardBus cycle to PCI. Bits 31–12 of these registers are read/write and allow the memory base to be located anywhere in the 32-bit PCI memory space on 4-Kbyte boundaries. Bits 11–0 are read-only and always return 0s. Writes to these bits have no effect. Bits 8 and 9 of the bridge control register specify whether memory windows 0 and 1 are prefetchable or nonprefetchable. The memory base register or the memory limit register must be nonzero in order for the PCI4450 to claim any memory transactions through CardBus memory windows (i.e., these windows are not enabled by default to pass the first 4K bytes of memory to CardBus).

# PCI4450 GFN/GJG PC Card and OHCI Controller

SCPS046 – JANUARY 1999

## memory limit registers 0, 1

Bit	31	30	29	28	27	26	25	24	23	22	21	20	19	18	17	16
<b>Name</b>	Memory limit registers 0, 1															
<b>Type</b>	R/W	R/W	R/W	R/W	R/W	R/W	R/W	R/W	R/W	R/W	R/W	R/W	R/W	R/W	R/W	R/W
<b>Default</b>	0	0	0	0	0	0	0	0	0	0	0	0	0	0	0	0
Bit	15	14	13	12	11	10	9	8	7	6	5	4	3	2	1	0
<b>Name</b>	Memory limit registers 0, 1															
<b>Type</b>	R/W	R/W	R/W	R/W	R	R	R	R	R	R	R	R	R	R	R	R
<b>Default</b>	0	0	0	0	0	0	0	0	0	0	0	0	0	0	0	0

Register: **Memory limit registers 0, 1**

Type: Read-only, Read/Write

Offset: 20h, 28h

Default: 0000 0000h

Description: These registers indicate the upper address of a PCI memory address range. They are used by the PCI4450 to determine when to forward a memory transaction to the CardBus bus, and likewise, when to forward a CardBus cycle to PCI. Bits 31–12 of these registers are read/write and allow the memory base to be located anywhere in the 32-bit PCI memory space on 4-Kbyte boundaries. Bits 11–0 are read-only and always return 0s. Writes to these bits have no effect. Bits 8 and 9 of the bridge control register specify whether memory windows 0 and 1 are prefetchable or nonprefetchable. The memory base register or the memory limit register must be nonzero in order for the PCI4450 to claim any memory transactions through CardBus memory windows (i.e., these windows are not enabled by default to pass the first 4K bytes of memory to CardBus).

## I/O base registers 0, 1

Bit	31	30	29	28	27	26	25	24	23	22	21	20	19	18	17	16
<b>Name</b>	I/O base registers 0, 1															
<b>Type</b>	R	R	R	R	R	R	R	R	R	R	R	R	R	R	R	R
<b>Default</b>	0	0	0	0	0	0	0	0	0	0	0	0	0	0	0	0
Bit	15	14	13	12	11	10	9	8	7	6	5	4	3	2	1	0
<b>Name</b>	I/O base registers 0, 1															
<b>Type</b>	R/W	R/W	R/W	R/W	R/W	R/W	R/W	R/W	R/W	R/W	R/W	R/W	R/W	R/W	R	R
<b>Default</b>	0	0	0	0	0	0	0	0	0	0	0	0	0	0	0	0

Register: **I/O base registers 0, 1**

Type: Read-only, Read/Write

Offset: 2Ch, 34h

Default: 0000 0000h

Description: These registers indicate the lower address of a PCI I/O address range. They are used by the PCI4450 to determine when to forward an I/O transaction to the CardBus bus, and likewise, when to forward a CardBus cycle to the PCI bus. The lower 16 bits of this register locate the bottom of the I/O window within a 64-Kbyte page, and the upper 16 bits (31–16) are all 0s which locate this 64-Kbyte page in the first page of the 32-bit PCI I/O address space. Bits 31–16 and bits 1–0 are read-only and always return 0s, forcing I/O windows to be aligned on a natural doubleword boundary in the first 64-Kbyte page of PCI I/O address space. These I/O windows are enabled when either the I/O base register or the I/O limit register are nonzero. The I/O windows are not enabled by default to pass the first doubleword of I/O to CardBus.

Either the I/O base or the I/O limit register must be nonzero to enable any I/O transactions.



**I/O limit registers 0, 1**

<b>Bit</b>	31	30	29	28	27	26	25	24	23	22	21	20	19	18	17	16
<b>Name</b>	I/O limit registers 0, 1															
<b>Type</b>	R	R	R	R	R	R	R	R	R	R	R	R	R	R	R	R
<b>Default</b>	0	0	0	0	0	0	0	0	0	0	0	0	0	0	0	0
<b>Bit</b>	15	14	13	12	11	10	9	8	7	6	5	4	3	2	1	0
<b>Name</b>	I/O limit registers 0, 1															
<b>Type</b>	R/W	R/W	R/W	R/W	R/W	R/W	R/W	R/W	R/W	R/W	R/W	R/W	R/W	R/W	R	R
<b>Default</b>	0	0	0	0	0	0	0	0	0	0	0	0	0	0	0	0

Register: **I/O limit registers 0, 1**

Type: Read-only, Read/Write

Offset: 30h, 38h

Default: 0000 0000h

Description: These registers indicate the upper address of a PCI I/O address range. They are used by the PCI4450 to determine when to forward an I/O transaction to the CardBus bus, and likewise, when to forward a CardBus cycle to PCI. The lower 16 bits of this register locate the top of the I/O window within a 64-Kbyte page, and the upper 16 bits are a page register which locates this 64-Kbyte page in 32-bit PCI I/O address space. Bits 15–2 are read/write and allow the I/O limit address to be located anywhere in the 64-Kbyte page (indicated by bits 31–16 of the appropriate I/O base register) on doubleword boundaries.

Bits 31–16 are read-only and always return 0s when read. The page is set in the I/O base register. Bits 1–0 are read-only and always return 0s, forcing I/O windows to be aligned on a natural doubleword boundary. Writes to read-only bits have no effect. The PCI4450 assumes that the lower two bits of the limit address are ones.

These I/O windows are enabled when either the I/O base register or the I/O limit register are nonzero. The I/O windows are not enabled by default to pass the first doubleword of I/O to CardBus.

Either the I/O base or the I/O limit register must be nonzero to enable any I/O transactions.

**interrupt line register**

<b>Bit</b>	7	6	5	4	3	2	1	0
<b>Name</b>	Interrupt line							
<b>Type</b>	R/W	R/W	R/W	R/W	R/W	R/W	R/W	R/W
<b>Default</b>	1	1	1	1	1	1	1	1

Register: **Interrupt line**

Type: Read/Write

Offset: 3Ch

Default: FFh

Description: This register communicates interrupt line routing information to the host system. This register is not used by the PCI4450, since there are many programmable interrupt signaling options. This register is considered reserved; however, host software may read and write to this register. Each PCI4450 function has an interrupt line register.

# PCI4450 GFN/GJG PC Card and OHCI Controller

SCPS046 – JANUARY 1999

## interrupt pin register

PCI function 0

Bit	7	6	5	4	3	2	1	0
Name	Interrupt pin – PCI function 0							
Type	R	R	R	R	R	R	R	R
Default	0	0	0	0	0	0	0	1

PCI function 1

Bit	7	6	5	4	3	2	1	0
Name	Interrupt pin – PCI function 1							
Type	R	R	R	R	R	R	R	R
Default	0	0	0	0	0	0	1	0

Register: **Interrupt pin**  
 Type: Read-only  
 Offset: 3Dh  
 Default: The default depends on the interrupt signaling mode.  
 Description: The value read from this register is function dependent. The value depends on two interrupt tie bits (INTRTIE and TIEALL) in the system control register. INTRTIE is compatible with other TI CardBus controllers and ties  $\overline{INTA}$  to  $\overline{INTB}$  internally. The TIEALL bit ties  $\overline{INTA}$ ,  $\overline{INTB}$ , and  $\overline{INTC}$  together internally. The internal interrupt connections set by INTRTIE and TIEALL are communicated to host software through this standard register interface. Refer to Table 28 for a complete description of the register contents.

**Table 28. Interrupt Pin Register Cross Reference**

INTRTIE Bit	TIEALL Bit	INTPIN Function 0	INTPIN Function 1	INTPIN Function 2
0	0	0x01 ( $\overline{INTA}$ )	0x02 ( $\overline{INTB}$ )	0x03 ( $\overline{INTC}$ )
1	0	0x01 ( $\overline{INTA}$ )	0x01 ( $\overline{INTA}$ )	0x03 ( $\overline{INTC}$ )
x	1	0x01 ( $\overline{INTA}$ )	0x01 ( $\overline{INTA}$ )	0x01 ( $\overline{INTA}$ )

## bridge control register

Bit	15	14	13	12	11	10	9	8	7	6†	5	4	3	2	1	0
Name	Bridge control															
Type	R	R	R	R	R	R/W	R/W	R/W	R/W	R/W	R/W	R	R/W	R/W	R/W	R/W
Default	0	0	0	0	0	0	1	1	0	1	0	0	0	0	0	0

Register: **Bridge control**  
 Type: Read-only, Read/Write  
 Offset: 3Eh (Function 0, 1)  
 Default: 0340h  
 Description: This register provides control over various PCI4450 bridging functions. Some bits in this register are global in nature and should be accessed only through function 0.





**Table 29. Bridge Control Register Description**

BIT	TYPE	FUNCTION
15–11	R	Reserved. These bits return 0s when read.
10	R/W	POSTEN. Write posting enable. Enables write posting to and from the CardBus sockets. Write posting enables posting of write data on burst cycles. Operating with write posting disabled will inhibit performance on burst cycles. Note that bursted write data can be posted, but various write transactions may not. This bit is socket dependent and is not shared between functions 0 and 1.
9	R/W	PREFETCH1. Memory window 1 type. This bit specifies whether or not memory window 1 is prefetchable. This bit is socket dependent. This bit is encoded as: 0 = Memory window 1 is nonprefetchable. 1 = Memory window 1 is prefetchable (default).
8	R/W	PREFETCH0. Memory window 0 type. This bit specifies whether or not memory window 0 is prefetchable. This bit is encoded as: 0 = Memory window 0 is nonprefetchable. 1 = Memory window 0 is prefetchable (default).
7	R/W	PCI Interrupt – IREQ routing enable. This bit is used to select whether PC Card functional interrupts are routed to PCI interrupts or to the IRQ specified in the ExCA registers. 0 = Functional interrupts are routed to PCI interrupts (default). 1 = Functional interrupts are routed by ExCA registers.
6†	R/W	CRST. CardBus reset. When this bit is set, the $\overline{\text{CRST}}$ signal is asserted on the CardBus interface. The $\overline{\text{CRST}}$ signal may also be asserted by passing a $\overline{\text{PRST}}$ assertion to CardBus. 0 = $\overline{\text{CRST}}$ is deasserted. 1 = $\overline{\text{CRST}}$ is asserted (default). This bit will not be cleared by the assertion of $\overline{\text{PRST}}$ . It will only be cleared by the assertion of $\overline{\text{G\_RST}}$ .
5§	R/W	MABTMODE. Master abort mode. This bit controls how the PCI4450 responds to a master abort when the PCI4450 is an initiator on the CardBus interface. This bit is common between each socket. 0 = Master aborts not reported (default). 1 = Signal target abort on PCI and signal $\overline{\text{SERR}}$ , if enabled.
4	R	Reserved. This bit returns 0 when read.
3	R/W	VGAEN. VGA enable. This bit affects how the PCI4450 responds to VGA addresses. When this bit is set, accesses to VGA addresses will be forwarded.
2	R/W	ISAEN. ISA mode enable. This bit affects how the PCI4450 passes I/O cycles within the 64-Kbyte ISA range. This bit is not common between sockets. When this bit is set, the PCI4450 will not forward the last 768 bytes of each 1K I/O range to CardBus.
1	R/W	CSERREN. $\overline{\text{CSERR}}$ enable. This bit controls the response of the PCI4450 to $\overline{\text{CSERR}}$ signals on the CardBus bus. This bit is separate for each socket. 0 = $\overline{\text{CSERR}}$ is not forwarded to PCI $\overline{\text{SERR}}$ . 1 = $\overline{\text{CSERR}}$ is forwarded to PCI $\overline{\text{SERR}}$ .
0	R/W	CPERREN. CardBus parity error response enable. This bit controls the response of the PCI4450 to CardBus parity errors. This bit is separate for each socket. 0 = CardBus parity errors are ignored. 1 = CardBus parity errors are reported using $\overline{\text{CPERR}}$ .

† This bit is cleared only by the assertion of  $\overline{\text{G\_RST}}$  when PME is enabled. If PME is not enabled, then this bit is cleared by the assertion of  $\overline{\text{PRST}}$  or  $\overline{\text{G\_RST}}$ .

§ These bits are global in nature and should be accessed only through function 0.

# PCI4450 GFN/GJG PC Card and OHCI Controller

SCPS046 – JANUARY 1999

## subsystem vendor ID register

Bit	15‡	14‡	13‡	12‡	11‡	10‡	9‡	8‡	7‡	6‡	5‡	4‡	3‡	2‡	1‡	0‡
Name	Subsystem vendor ID															
Type	R	R	R	R	R	R	R	R	R	R	R	R	R	R	R	R
Default	0	0	0	0	0	0	0	0	0	0	0	0	0	0	0	0

‡ This bit is cleared only by the assertion of  $\overline{G\_RST}$ .

Register: **Subsystem vendor ID**  
 Type: Read-only, Read/Write (when bit 5 in the system control register is 0.)  
 Offset: 40h (Functions 0, 1)  
 Default: 0000h  
 Description: This register, used for system and option card identification purposes, may be required for certain operating systems. This register is read-only or read/write, depending on the setting of bit 5 (SUBSYSRW) in the system control register. When bit 5 is 0, this register is read/write; when bit 5 is 1, this register is read-only. The default mode is read-only.

## subsystem ID register

Bit	15‡	14‡	13‡	12‡	11‡	10‡	9‡	8‡	7‡	6‡	5‡	4‡	3‡	2‡	1‡	0‡
Name	Subsystem ID															
Type	R	R	R	R	R	R	R	R	R	R	R	R	R	R	R	R
Default	0	0	0	0	0	0	0	0	0	0	0	0	0	0	0	0

‡ This bit is cleared only by the assertion of  $\overline{G\_RST}$ .

Register: **Subsystem ID**  
 Type: Read-only, Read/Write (when bit 5 in the system control register is 0.)  
 Offset: 42h (Functions 0, 1)  
 Default: 0000h  
 Description: This register, used for system and option card identification purposes, may be required for certain operating systems. This register is read-only or read/write, depending on the setting of bit 5 (SUBSYSRW) in the system control register. When bit 5 is 0, this register is read/write; when bit 5 is 1, this register is read-only. The default mode is read-only.

If an EEPROM is present, then the subsystem ID and subsystem vendor ID will be loaded from EEPROM after a reset.



**PC Card 16-bit I/F legacy mode base address register**

<b>Bit</b>	<b>31‡</b>	<b>30‡</b>	<b>29‡</b>	<b>28‡</b>	<b>27‡</b>	<b>26‡</b>	<b>25‡</b>	<b>24‡</b>	<b>23‡</b>	<b>22‡</b>	<b>21‡</b>	<b>20‡</b>	<b>19‡</b>	<b>18‡</b>	<b>17‡</b>	<b>16‡</b>
<b>Name</b>	PC Card 16-bit I/F legacy mode base address															
<b>Type</b>	R/W	R/W	R/W	R/W	R/W	R/W	R/W	R/W	R/W	R/W	R/W	R/W	R/W	R/W	R/W	R/W
<b>Default</b>	0	0	0	0	0	0	0	0	0	0	0	0	0	0	0	0
<b>Bit</b>	<b>15‡</b>	<b>14‡</b>	<b>13‡</b>	<b>12‡</b>	<b>11‡</b>	<b>10‡</b>	<b>9‡</b>	<b>8‡</b>	<b>7‡</b>	<b>6‡</b>	<b>5‡</b>	<b>4‡</b>	<b>3‡</b>	<b>2‡</b>	<b>1‡</b>	<b>0</b>
<b>Name</b>	PC Card 16-bit I/F legacy mode base address															
<b>Type</b>	R/W	R/W	R/W	R/W	R/W	R/W	R/W	R/W	R/W	R/W	R/W	R/W	R/W	R/W	R/W	R
<b>Default</b>	0	0	0	0	0	0	0	0	0	0	0	0	0	0	0	1

‡ This bit is cleared only by the assertion of  $\overline{G\_RST}$ .

Register: **PC Card 16-bit I/F legacy mode base address**

Type: Read-only, Read/Write

Offset: 44h (Functions 0, 1)

Default: 0000 0001h

Description: The PCI4450 supports the index/data scheme of accessing the ExCA registers, which is mapped by this register. An address written to this register is the address for the index register and the address+1 is the data address. Using this access method, applications requiring index/data ExCA access can be supported. The base address can be mapped anywhere in 32-bit I/O space on a word boundary; hence, bit 0 is read-only returning 1 when read. As specified in the Yenta specification, this register is shared by functions 0 and 1. Refer to the ExCA register set description for register offsets.

**system control register**

<b>Bit</b>	<b>31‡</b>	<b>30‡</b>	<b>29‡</b>	<b>28</b>	<b>27‡</b>	<b>26‡</b>	<b>25‡</b>	<b>24‡</b>	<b>23</b>	<b>22‡</b>	<b>21‡</b>	<b>20‡</b>	<b>19‡</b>	<b>18‡</b>	<b>17‡</b>	<b>16‡</b>
<b>Name</b>	System control															
<b>Type</b>	R/W	R/W	R/W	R/W	R/W	R/W	R/W	R/W	R	R/W	R/W	R/W	R/W	R/W	R/W	R/W
<b>Default</b>	0	0	0	0	0	0	0	0	0	0	0	0	0	0	0	0
<b>Bit</b>	<b>15‡</b>	<b>14‡</b>	<b>13</b>	<b>12</b>	<b>11</b>	<b>10</b>	<b>9</b>	<b>8</b>	<b>7</b>	<b>6‡</b>	<b>5‡</b>	<b>4‡</b>	<b>3‡</b>	<b>2</b>	<b>1‡</b>	<b>0‡</b>
<b>Name</b>	System control															
<b>Type</b>	R/W	R/W	R	R	R	R	R	R	R	R/W	R/W	R/W	R/W	R	R/W	R/W
<b>Default</b>	0	0	0	0	0	0	0	0	0	0	1	0	0	0	0	0

‡ This bit is cleared only by the assertion of  $\overline{G\_RST}$ .

Register: **System control**

Type: Read-only, Read/Write

Offset: 80h (Functions 0, 1)

Default: 0000 0020h

Description: System level initializations are performed through programming this doubleword register. Some of the bits are global in nature and should be accessed only through function 0.

# PCI4450 GFN/GJG PC Card and OHCI Controller

SCPS046 – JANUARY 1999

**Table 30. System Control Register Description**

BIT	TYPE	FUNCTION
31–30‡§	R/W	SER_STEP. Serialized PCI interrupt routing step. These bits are used to configure the serialized PCI interrupt stream signaling and accomplish an even distribution of interrupts signaled on the four PCI interrupt slots. These bits are global to both PCI4450 functions. 00 = <u>INTA/INTB/INTC</u> signal in <u>INTA/INTB/INTC</u> slots (default) 01 = <u>INTA/INTB/INTC</u> signal in <u>INTB/INTC/INTD</u> slots 10 = <u>INTA/INTB/INTC</u> signal in <u>INTC/INTD/INTA</u> slots 11 = <u>INTA/INTB/INTC</u> signal in <u>INTD/INTA/INTB</u> slots
29‡§	R/W	INTRTIE. Tie internal PCI interrupts. When this bit is set, the <u>INTA</u> and <u>INTB</u> signals are tied together internally and are signaled as <u>INTA</u> . <u>INTA</u> may then be shifted by using the SER_STEP bits. This bit is global to both PCI4450 functions. This bit has no effect on <u>INTC</u> . 0 = <u>INTA</u> and <u>INTB</u> are not tied together internally (default). 1 = <u>INTA</u> and <u>INTB</u> are tied together internally.
28	R/W	TIEALL. This bit ties <u>INTA</u> , <u>INTB</u> , and <u>INTC</u> internally (to <u>INTA</u> ) and reports this through the interrupt pin register.
27‡§	R/W	P2CCLK. P2C power switch CLOCK. This bit determines whether the CLOCK terminal (terminal U12) is an input that requires an external clock source or if this terminal is an output that uses the internal oscillator. 0 = CLOCK terminal (terminal U12) is an input (default) (disabled). 1 = CLOCK terminal is an output, the PCI4450 generated CLOCK. A 43kΩ pulldown resistor should be tied to this terminal.
26‡§	R/W	SMIROUTE. SMI interrupt routing. This bit is shared between functions 0 and 1, and selects whether IRQ2 or CSC is signaled when a write occurs to power a PC Card socket. 0 = PC Card power change interrupts routed to IRQ2 (default). 1 = A CSC interrupt is generated on PC Card power changes.
25‡	R/W	SMISTATUS. SMI interrupt status. This socket dependent bit is set when a write occurs to set the socket power, and the SMIENB bit is set. Writing a 1 to this bit clears the status. 0 = SMI interrupt is signaled. 1 = SMI interrupt is not signaled.
24‡§	R/W	SMIENB. SMI interrupt mode enable. When this bit is set, the SMI interrupt signaling generates an interrupt when a write to the socket power control occurs. This bit is shared and defaults to 0 (disabled). 0 = SMI interrupt mode is disabled (default). 1 = SMI interrupt mode is enabled.
23	R	Reserved
22‡	R/W	CBRSVD. CardBus reserved terminals signaling. When this bit is set, the RSVD CardBus terminals will be driven low when a CardBus card is inserted. When this bit is low, as default, these signals are placed in a high-impedance state. 0 = Place the CardBus RSVD terminals in a high-impedance state 1 = Drive the Cardbus RSVD terminals low (default).
21‡	R/W	VCCPROT. VCC protection enable. This bit is socket dependent. 0 = VCC protection is enabled for 16-bit cards (default). 1 = VCC protection is disabled for 16-bit cards.
20‡	R/W	Reduced zoomed video enable. When this bit is enabled, A25–22 of the card interface for PC Card 16 cards is placed in the high impedance state. This bit is encoded as: 0 = Reduced zoomed video is disabled (default). 1 = Reduced zoomed video is enabled.
19‡	R/W	CDREQEN. PC/PCI DMA card enable. When this bit is set, the PCI4450 allows 16-bit PC Cards to request PC/PCI DMA using the <u>DREQ</u> signaling. <u>DREQ</u> is selected through the socket DMA register 0. 0 = Ignore <u>DREQ</u> signaling from PC Cards (default). 1 = Signal DMA request on <u>DREQ</u> .
18–16‡	R/W	CDMACHAN. PC/PCI DMA channel assignment. These bits are encoded as: 0–3 = 8-bit DMA channels 4 = PCI master; not used (default) 5–7 = 16-bit DMA channels

§ These bits are global in nature and should be accessed only through function 0.

‡ This bit is cleared only by the assertion of G\_RST.



**Table 30. System Control Register Description (continued)**

BIT	TYPE	FUNCTION
15‡§	R/W	MRBURSTDN. Memory read burst enable downstream. When this bit is set, memory read transactions are allowed to burst downstream. 0 = MRBURSTDN downstream is disabled. 1 = MRBURSTDN downstream is enabled (default).
14‡§	R/W	MRBURSTUP. Memory read burst enable upstream. When this bit is set, the PCI4450 allows memory read transactions to burst upstream. 0 = MRBURSTUP upstream is disabled (default). 1 = MRBURSTUP upstream is enabled.
13	R	SOCACTIVE. Socket activity status. When set, this bit indicates access has been performed to or from a PC Card, and is cleared upon read of this status bit. This bit is socket dependent. 0 = No socket activity (default) 1 = Socket activity
12	R	Reserved. This bit returns 1 when read. This is the power rail bit in functions 0 and 1.
11	R	PWRSTREAM. Power stream in progress status bit. When set, this bit indicates that a power stream to the power switch is in progress and a powering change has been requested. When this bit is clear, it indicates that the power stream is complete. 0 = Power stream is complete, delay has expired. 1 = Power stream is in progress.
10	R	DELAYUP. Power-up delay in progress status bit. When set, this bit indicates that a power-up stream has been sent to the power switch, and proper power may not yet be stable. This bit is cleared when the power-up delay has expired. 0 = Power-up delay has expired. 1 = Power-up stream sent to switch. Power might not be stable.
9	R	DELAYDOWN. Power-down delay in progress status bit. When set, this bit indicates that a power-down stream has been sent to the power switch, and proper power may not yet be stable. This bit is cleared when the power-down delay has expired. 0 = Power-down delay has expired. 1 = Power-down stream sent to switch. Power might not be stable.
8	R	INTERROGATE. Interrogation in progress. When set, this bit indicates an interrogation is in progress, and clears when the interrogation completes. This bit is socket dependent. 0 = Interrogation not in progress (default) 1 = Interrogation in progress
7	R	Reserved. This bit returns 0 when read.
6‡§	R/W	PWRSAVINGS. Power savings mode enable. When this bit is set, the PCI4450 will consume less power with no performance loss. This bit is shared between the two PCI4450 functions. 0 = Power savings mode disabled 1 = Power savings mode enabled (default)
5‡§	R/W	SUBSYSRW. Subsystem ID (SS ID), subsystem vendor ID (SS VID), and the ExCA identification and revision registers read/write enable. This bit is shared by functions 0 and 1. This bit does not control read/write of function 2, subsystem ID register. 0 = Subsystem ID, subsystem vendor ID, and the ExCA identification and revision registers are read/write. 1 = Subsystem ID, subsystem vendor ID, and the ExCA identification and revision registers are read-only (default).
4‡§	R/W	CB_DPAR. CardBus data parity SERR signaling enable. 0 = CardBus data parity not signaled on PCI <u>SERR</u> signal (default) 1 = CardBus data parity signaled on PCI <u>SERR</u> signal
3‡§	R/W	CDMA_EN. PC/PCI DMA enable. Enables PC/PCI DMA when set. When PC/PCI DMA is enabled, <u>PCREQ</u> and <u>PCGNT</u> should be routed to a multifunction routing terminal. See multifunction routing status register for options. 0 = Centralized DMA disabled (default) 1 = Centralized DMA enabled
2	R	Reserved. This bit returns 0 when read.

§ These bits are global in nature and should be accessed only through function 0.

‡ This bit is cleared only by the assertion of G\_RST.

# PCI4450 GFN/GJG PC Card and OHCI Controller

SCPS046 – JANUARY 1999

**Table 30. System Control Register Description (continued)**

BIT	TYPE	FUNCTION
1‡§	R/W	<p>KEEPCLK. Keep clock. When this bit is set, the PCI4450 will always follow <u>CLKRUN</u> protocol to maintain the system PCLK and the CCLK (CardBus clock). This bit is global to the PCI4450 functions.</p> <p>0 = Allow system PCLK and CCLK to stop (default) 1 = Never allow system PCLK or CCLK clock to stop</p> <p>Note that the functionality of this bit has changed versus the PCI12XX series of TI CardBus controllers. In these CardBus controllers, setting this bit would only maintain the PCI clock, not the CCLK. In the PCI4450, setting this bit will maintain both the PCI clock and the CCLK.</p>
0‡§	R/W	<p><u>PME/RI_OUT</u> select bit. When this bit is 1, the PME signal is routed on to pin Y13 (<u>PME/RI_OUT</u> pin). When this bit is 0 and bit 7 (RIENB) of the card control register is 1, the <u>RI_OUT</u> signal is routed on to pin Y13 (GFN) or pin R11 (GJG). If this bit is 0 and bit 7 (RIENB) of the card control register is 0, then the output (Y13 or R11) will be placed in a high-impedance state. This pin is encoded as:</p> <p>0 = <u>RI_OUT</u> signal is routed to pin Y13 (GFN) or pin R11 (GJG) if bit 7 of the card control register is 1*. (default) 1 = <u>PME</u> signal is routed on pin Y13 (GFN) or pin R11 (GJG) of the PCI4450 controller.</p> <p>NOTE: If this bit (bit 0) is 0 and bit 7 of the card control register is 0, then the output on pin Y13 (GFN) or pin R11 (GJG) is placed in a high-impedance state.</p>

§ These bits are global in nature and should be accessed only through function 0.

‡ This bit is cleared only by the assertion of G\_RST.



**multimedia control register**

Bit	7‡	6‡	5‡	4‡	3‡	2‡	1‡	0‡
Name	Multimedia control							
Type	R/W	R/W	R/W	R/W	R/W	R/W	R/W	R/W
Default	0	0	0	0	0	0	0	0

Register: **Multimedia control**

Type: Read/Write

Offset: 84h (Functions 0, 1)

Default: 00h

Description: This register provides port mapping for the PCI4450 zoomed video/data ports. See *zoomed video support* for details on the PCI4450 zoomed video support. Access this register only through function 0.

**Table 31. Multimedia Control Register Description**

BIT	TYPE	FUNCTION
7‡	R/W	ZVOUTEN. ZV output enable. This bit enables the output for the PCI4450 outsourcing ZV terminals. When this bit is reset, '0', these terminals are in a high impedance state. 0 = PCI4450 ZV output terminals disabled (default) 1 = PCI4450 ZV output terminals enabled
6‡	R/W	PORTSEL. ZV port select. This bit controls the multiplexing control over which PC Card ZV port data will be driven to the outsourcing PCI4450 ZV port. 0 = Output card 0 ZV if enabled (default) 1 = Output card 1 ZV if enabled
5‡	R/W	Zoomed video auto-detect. This bit enables the zoomed video auto-detect feature. This bit is encoded as: 0 = Zoomed video auto detect disabled (default) 1 = Zoomed video auto detect enabled
4–2‡	R/W	Auto-detect priority encoding. These bits have meaning only if zoomed video auto-detect is enabled in bit 5 of this register. If auto-detect is enabled, then bits 4–2 are encoded as follows: 000 = Slot A, Slot B, External Source 001 = Slot A, External Source, Slot B 010 = Slot B, Slot A, External Source 011 = Slot B, External Source, Slot A 100 = External Source, Slot A, Slot B 101 = External Source, Slot B, Slot A 110 = Reserved 111 = Reserved
1‡	R/W	ZVEN1. PC Card 1 ZV mode enable. Enables the zoomed video mode for socket 1. When set, the PCI4450 inputs ZV data from the PC Card interface, and disables output drivers on ZV terminals. 0 = PC Card 1 ZV disabled (default) 1 = PC Card 1 ZV enabled
0‡	R/W	ZVEN0. PC Card 0 ZV mode enable. Enables the zoomed video mode for socket 0. When set, the PCI4450 inputs ZV data from the PC Card interface, and disables output drivers on ZV terminals. 0 = PC Card 0 ZV disabled (default) 1 = PC Card 0 ZV enabled

‡ This bit is cleared only by the assertion of  $\overline{G\_RST}$ .

# PCI4450 GFN/GJG PC Card and OHCI Controller

SCPS046 – JANUARY 1999

## general status register

Bit	7	6	5	4	3	2‡	1‡	0‡
Name	General status							
Type	R/U	R	R	R	R	R/U	R	R
Default	0	0	0	0	0	X	0	0

Register: **General status**

Type: Read/Update

Offset: 85h (Functions 0)

Default: 00h

Description: This register provides the general device status information. The status of the serial EEPROM interface is provided through this register.

**Table 32. General Status Register Description**

BIT	TYPE	FUNCTION
7	R/U	IDSEL_DET. When this bit is set, the IDSEL/MFUNC7 terminal functions as an IDSEL input.
6–3	R	Reserved. These bits return 0s when read.
2‡§	R/U	EEDETECT. Serial EEPROM detect. Serial EEPROM is detected by sampling a logic high on SCL on $\overline{\text{PRST}}$ . When this bit is set, the serial ROM is detected. This status bit is encoded as: 0 = EEPROM not detected (default) 1 = EEPROM detected
1‡§	R	DATAERR. Serial EEPROM data error status. This bit indicates when a data error occurs on the serial EEPROM interface. This bit may be set due to a missing acknowledge. This bit is cleared by a writing a 1. 0 = No error detected. (default) 1 = Data error detected.
0‡§	R	EEBUSY. Serial EEPROM busy status. This bit indicates the status of the PCI4450 serial EEPROM circuitry. This bit is set during the loading of the subsystem ID value. 0 = Serial EEPROM circuitry is not busy (default). 1 = Serial EEPROM circuitry is busy.

§ This bit is global in nature and should only be accessed through function 0.

‡ This bit is cleared only by the assertion of G\_RST.





**general control register**

Bit	7	6	5	4	3	2	1	0
Name	General control							
Type	R	R	R	R	R/W	R/W	R/W	R/W
Default	0	0	0	0	0	0	0	0

Register: **General control**  
 Type: Read-Only, Read/Write  
 Offset: 86h  
 Default: 00h  
 Description: This register provides top level PCI arbitration control.

**Table 33. General Control Register Description**

BIT	TYPE	FUNCTION
7–4	R	Reserved. These bits return 0s when read.
3	R/W	DISABLE_OHCI. When this bit is set, the open HCI 1394 controller function is completely nonaccessible and nonfunctional.
2	R/W	GP2IIC. When this bit is set, the GPO0 and GPO1 signals are routed to SDA and SCL, respectively.
1–0	R/W	ARB_CTRL. Controls top level PCI arbitration. 00 = 1394 open HCI priority 01 = CardBus priority 10 = Fair round robin 11 = Reserved (fair round robin)

# PCI4450 GFN/GJG PC Card and OHCI Controller

SCPS046 – JANUARY 1999

## general-purpose event status register

Bit	7‡	6‡	5	4	3‡	2‡	1‡	0‡
Name	General-purpose event status							
Type	RCU	RCU	R	R	RCU	RCU	RCU	RCU
Default	0	0	0	0	0	0	0	0

Register: **General-purpose event status**

Type: Read/Clear/Update

Offset: 88h

Default: 00h

Description: This register contains status bits that are set when general events occur and may be programmed to generate general-purpose event signalling through  $\overline{\text{GPE}}$ .

**Table 34. General-Purpose Event Status Register Description**

BIT	TYPE	FUNCTION
7‡	RCU	PWR_STS. Power change status. This bit is set when software changes the $V_{CC}$ or $V_{PP}$ power state of either socket.
6‡	RCU	VPP12_STS. 12V $V_{PP}$ request status. This bit is set when software has changed the requested $V_{PP}$ level to or from 12 V for either socket.
5–4	R	Reserved. This bit returns 0 when read. A write has no effect.
3‡	RCU	GP3_STS. GPI3 status. This bit is set on a change in status of the MFUNC3 terminal input level if configured as a general-purpose input, GPI3.
2‡	RCU	GP2_STS. GPI2 status. This bit is set on a change in status of the MFUNC2 terminal input level if configured as a general-purpose input, GPI2.
1‡	RCU	GP1_STS. GPI1 status. This bit is set on a change in status of the MFUNC1 terminal input level if configured as a general-purpose input, GPI1.
0‡	RCU	GP0_STS. GPI0 status. This bit is set on a change in status of the MFUNC0 terminal input level if configured as a general-purpose input, GPI0.

‡ This bit is cleared only by the assertion of  $\overline{\text{G\_RST}}$ .

**general-purpose event enable register**

Bit	7‡	6‡	5	4	3‡	2‡	1‡	0‡
Name	General-purpose event enable							
Type	R/W	R/W	R	R	R/W	R/W	R/W	R/W
Default	0	0	0	0	0	0	0	0

Register: **General-purpose event enable**  
 Type: Read-only, Read/Write  
 Offset: 89h  
 Default: 00h  
 Description: This register contains bits that are set to enable  $\overline{\text{GPE}}$  signals.

**Table 35. General-Purpose Event Enable Register Description**

BIT	TYPE	FUNCTION
7‡	R/W	PWR_EN. Power change $\overline{\text{GPE}}$ enable. When this bit is set, $\overline{\text{GPE}}$ is signaled on PWR_STS events.
6‡	R/W	VPP12_EN. 12-Volt V <sub>pp</sub> $\overline{\text{GPE}}$ enable. When this bit is set, $\overline{\text{GPE}}$ is signaled on VPP12_STS events.
5–4	R	Reserved. This bit returns 0 when read. A write has no effect.
3‡	R/W	GP3_EN. GPI3 $\overline{\text{GPE}}$ enable. When this bit is set, $\overline{\text{GPE}}$ is signaled on GP3_STS events.
2‡	R/W	GP2_EN. GPI2 $\overline{\text{GPE}}$ enable. When this bit is set, $\overline{\text{GPE}}$ is signaled on GP2_STS events.
1‡	R/W	GP1_EN. GPI1 $\overline{\text{GPE}}$ enable. When this bit is set, $\overline{\text{GPE}}$ is signaled on GP1_STS events.
0‡	R/W	GP0_EN. GPI0 $\overline{\text{GPE}}$ enable. When this bit is set, $\overline{\text{GPE}}$ is signaled on GP0_STS events.

‡ This bit is cleared only by the assertion of  $\overline{\text{G\_RST}}$ .

**general-purpose input register**

Bit	7	6	5	4	3‡	2‡	1‡	0‡
Name	General-purpose input							
Type	R	R	R	R	RU	RU	RU	RU
Default	0	0	0	0	x	x	x	x

Register: **General-purpose input**  
 Type: Read/Update  
 Offset: 8Ah  
 Default: 00h  
 Description: This register contains GPI terminal status.

**Table 36. General-Purpose Input Register Description**

BIT	TYPE	FUNCTION
7–4	R	Reserved. These bits return 0s when read. Writes have no effect.
3‡	RU	GPI3_DATA. GPI3 data input. This bit represents the logical value of the data input from GPI3.
2‡	RU	GPI2_DATA. GPI2 data input. This bit represents the logical value of the data input from GPI2.
1‡	RU	GPI1_DATA. GPI1 data input. This bit represents the logical value of the data input from GPI1.
0‡	RU	GPI0_DATA. GPI0 data input. This bit represents the logical value of the data input from GPI0.

‡ This bit is cleared only by the assertion of  $\overline{\text{G\_RST}}$ .

# PCI4450 GFN/GJG PC Card and OHCI Controller

SCPS046 – JANUARY 1999

## general-purpose output register

Bit	7	6	5	4	3‡	2‡	1‡	0‡
Name	General-purpose output							
Type	R	R	R	R	R/W	R/W	R/W	R/W
Default	0	0	0	0	0	0	0	0

Register: **General-purpose output**  
 Type: Read-only, Read/Write  
 Offset: 8Bh  
 Default: 00h  
 Description: This register is used to drive the GPO3–GPO0 outputs.

**Table 37. General-Purpose Output Register Description**

BIT	TYPE	FUNCTION
7–4	R	Reserved. These bits return 0s when read. Writes have no effect.
3‡	R/W	GPO3_DATA. This bit represents the logical value of the data driven to GPO3.
2‡	R/W	GPO2_DATA. This bit represents the logical value of the data driven to GPO2.
1‡	R/W	GPO1_DATA. This bit represents the logical value of the data driven to GPO1.
0‡	R/W	GPO0_DATA. This bit represents the logical value of the data driven to GPO0.

‡ This bit is cleared only by the assertion of  $\overline{G\_RST}$ .



**multifunction routing status register**

<b>Bit</b>	31	30	29	28	27	26	25	24	23	22	21	20	19	18	17	16
<b>Name</b>	Multifunction routing status															
<b>Type</b>	R/W	R/W	R/W	R/W	R/W	R/W	R/W	R/W	R/W	R/W	R/W	R/W	R/W	R/W	R/W	R/W
<b>Default</b>	0	0	0	0	0	0	0	0	0	0	0	0	0	0	0	0
<b>Bit</b>	15	14	13	12	11	10	9	8	7	6	5	4	3	2	1	0
<b>Name</b>	Multifunction routing status															
<b>Type</b>	R/W	R/W	R/W	R/W	R/W	R/W	R/W	R/W	R/W	R/W	R/W	R/W	R/W	R/W	R/W	R/W
<b>Default</b>	0	0	0	0	0	0	0	0	0	0	0	0	0	0	0	0

Register: **Multifunction routing status**

Type: Read/Write

Offset: 8Ch

Default: 0000 0000h

Description: This register is used to configure MFUNC7–MFUNC0 terminals. These terminals may be configured for various functions. This register is intended to be programmed once at power-on initialization. The default value for this register may also be loaded through a serial ROM.

**Table 38. Multifunction Routing Status Register Description**

BIT	TYPE	FUNCTION
31	R	Reserved. This bit returns 0 when read. Writes have no effect.
30–28	R/W	MFUNC7_SEL. MFUNC7 select. These bits control the mapping of MFUNC7 as follows: 000 = <u>IDSEL</u> 100 = <u>D3_STAT</u> 001 = <u>RI_OUT</u> 101 = <u>LOCK</u> 010 = <u>OHCI_LED</u> 110 = <u>RSVD</u> 011 = <u>PCREQ</u> 111 = <u>RSVD</u>
27	R	Reserved. This bit returns 0 when read. Writes have no effect.
26–24	R/W	MFUNC6_SEL. MFUNC6 select. These bits control the mapping of MFUNC6 as follows: 000 = <u>RSVD</u> 100 = <u>D3_STAT</u> 001 = <u>RSVD</u> 101 = <u>RSVD</u> 010 = <u>OHCI_LED</u> 110 = <u>CAUDPWM</u> 011 = <u>RSVD</u> 111 = <u>RSVD</u>
23	R	Reserved. This bit returns 0 when read. Writes have no effect.
22–20	R/W	MFUNC5_SEL. MFUNC5 select. These bits control the mapping of MFUNC5 as follows: 000 = <u>RSVD</u> 100 = <u>RSVD</u> 001 = <u>RSVD</u> 101 = <u>GPE</u> 010 = <u>OHCI_LED</u> 110 = <u>CAUDPWM</u> 011 = <u>RSVD</u> 111 = <u>RSVD</u>
19	R	Reserved. This bit returns 0 when read. Writes have no effect.
18–16	R/W	MFUNC4_SEL. MFUNC4 select. These bits control the mapping of MFUNC4 as follows: 000 = <u>RSVD</u> 100 = <u>RSVD</u> 001 = <u>RSVD</u> 101 = <u>GPE</u> 010 = <u>LEDA1</u> 110 = <u>RSVD</u> 011 = <u>PCREQ</u> 111 = <u>ZV_STAT</u>
15	R	Reserved. This bit returns 0 when read. Writes have no effect.
14–12	R/W	MFUNC3_SEL. MFUNC3 select. These bits control the mapping of MFUNC3 as follows: 000 = <u>GPI3</u> 100 = <u>RSVD</u> 001 = <u>GPO3</u> 101 = <u>LOCK</u> 010 = <u>LEDA2</u> 110 = <u>RSVD</u> 011 = <u>PCGNT</u> 111 = <u>C_ZVCLK</u>

# PCI4450 GFN/GJG PC Card and OHCI Controller

SCPS046 – JANUARY 1999

**Table 38. Multifunction Routing Status Register Description (continued)**

BIT	TYPE	FUNCTION
11	R	Reserved. This bit returns 0 when read. Writes have no effect.
10–8	R/W	MFUNC2_SEL. MFUNC2 select. These bits control the mapping of MFUNC2 as follows: 000 = GPI2                      100 = $\overline{D3\_STAT}$ 001 = $\overline{GPO2}$ 101 = RSVD 010 = $\overline{INTC}$ 110 = RSVD 011 = $\overline{PCGNT}$ 111 = C_ZVCLK
7	R	Reserved. This bit returns 0 when read. Writes have no effect.
6–4	R/W	MFUNC1_SEL. MFUNC1 select. These bits control the mapping of MFUNC1 as follows: 000 = GPI1                      100 = $\overline{D3\_STAT}$ 001 = $\overline{GPO1}$ 101 = LOCK 010 = $\overline{INTB}$ 110 = CAUDPWM 011 = TEST_MUX              111 = ZV_STAT
3	R	Reserved. This bit returns 0 when read. Writes have no effect.
2–0	R/W	MFUNC0_SEL. MFUNC0 select. These bits control the mapping of MFUNC0 as follows: 000 = GPIO                      100 = RSVD 001 = $\overline{GPO0}$ 101 = $\overline{GPE}$ 010 = $\overline{INTA}$ 110 = RSVD 011 = $\overline{PCREQ}$ 111 = ZV_STAT



retry status register

Bit	7‡	6‡	5‡	4	3‡	2	1‡	0
Name	Retry status							
Type	R/W	R/W	R/WC	R	R/WC	R	R/WC	R
Default	1	1	0	0	0	0	0	0

Register: **Retry status**

Type: Read-only, Read/Write

Offset: 90h (Functions 0, 1)

Default: C0h

Description: The contents of this register enable the retry time-out counters and display the retry expiration status. The flags are set when the PCI4450 retries a PCI or CardBus master request, and the master does not return within  $2^{15}$  PCI clock cycles. The flags are cleared by writing a 1 to the bit. These bits are expected to be incorporated into the PCI command register, PCI status register, and bridge control register by the PCI SIG. Access this register only through function 0.

Table 39. Retry Status Register Description

BIT	TYPE	FUNCTION
7‡	R/W	PCIRETRY. PCI retry time-out counter enable. This bit is encoded as: 0 = PCI retry counter disabled 1 = PCI retry counter enabled (default)
6‡§	R/W	CBRETRY. CardBus retry time-out counter enable. This bit is encoded as: 0 = CardBus retry counter disabled 1 = CardBus retry counter enabled (default)
5‡	R/WC	TEXP_CBB. CardBus target B retry expired. Write a 1 to clear this bit. 0 = Inactive (default) 1 = Retry has expired.
4	R	Reserved. This bit returns 0 when read.
3‡§	R/WC	TEXP_CBA. CardBus target A retry expired. Write a 1 to clear this bit. 0 = Inactive (default) 1 = Retry has expired.
2	R	Reserved. This bit returns 0 when read.
1‡	R/WC	TEXP_PCI. PCI target retry expired. Write a 1 to clear this bit. 0 = Inactive (default) 1 = Retry has expired.
0	R	Reserved. This bit returns 0 when read.

§ These bits are global in nature and should be accessed only through function 0.

‡ This bit is cleared only by the assertion of  $\overline{G\_RST}$ .

# PCI4450 GFN/GJG PC Card and OHCI Controller

SCPS046 – JANUARY 1999

## card control register

Bit	7‡	6‡	5	4	3	2‡	1‡	0‡
Name	Card control							
Type	R/W	R/W	R/W	R	R	R/W	R/W	R/W
Default	0	0	0	0	0	0	0	0

Register: **Card control**

Type: Read-only, Read/Write

Offset: 91h

Default: 00h

Description: This register is provided for PCI1130 compatibility. The contents provide the PC Card function interrupt flag (IFG) and an alias for the ZVEN0 and ZVEN1 bits found in the PCI4450 multimedia control register. When this register is accessed by function 0, the ZVEN0 bit will alias with ZVENABLE. When this register is accessed by function 1, the ZVEN1 bit will alias with ZVENABLE. Setting ZVENABLE only places the PC Card socket interface ZV terminals in a high impedance state, but does not enable the PCI4450 to drive ZV data onto the ZV terminals.

The  $\overline{\text{RI\_OUT}}$  signal is enabled through this register, and the enable bit is shared between functions 0 and 1.

**Table 40. Card Control Register Description**

BIT	TYPE	FUNCTION
7‡§	R/W	RIENB. Ring indicate enable. When this bit is 1, the $\overline{\text{RI\_OUT}}$ output is enabled. This bit is global in nature and should be accessed only through function 0. This bit defaults to 0.
6‡	R/W	ZVENABLE. Compatibility ZV mode enable. When this bit is 1, the corresponding PC Card socket interface ZV terminals will enter a high impedance state. This bit defaults to 0.
5	R/W	Reserved.
4–3	R	Reserved. These bits default to 0.
2‡	R/W	AUD2MUX. CardBus Audio-to-MFUNC. When this bit is set, the CAUDIO CardBus signal must be routed through an MFUNC terminal. If this bit is set for both functions, then function 0 gets routed. 0 = CAUDIO set to CAUDPWM on MFUNC pin (default) 1 = CAUDIO is not routed.
1‡	R/W	SPKROUTEN. Speaker output enable. When this bit is 1, it enables $\overline{\text{SPKR}}$ on the PC Card and routes it to SPKROUT on the PCI bus. The $\overline{\text{SPKR}}$ signal from socket 0 is XOR'ed with the $\overline{\text{SPKR}}$ signal from socket 1 and sent to SPKROUT. The SPKROUT terminal only drives data then either functions SPKROUTEN bit is set. This bit is encoded as: 0 = $\overline{\text{SPKR}}$ to SPKROUT not enabled (default) 1 = $\overline{\text{SPKR}}$ to SPKROUT enabled
0‡	R/W	IFG. Interrupt flag. This bit is the interrupt flag for 16-bit I/O PC Cards and for CardBus cards. This bit is set when a functional interrupt is signaled from a PC Card interface, and is socket dependent (i.e., not global). Write back a '1' to clear this bit. 0 = No PC Card functional interrupt detected (default) 1 = PC Card functional interrupt detected

§ These bits are global in nature and should be accessed only through function 0.

‡ This bit is cleared only by the assertion of G\_RST.





device control register

Bit	7‡	6‡	5‡	4	3‡	2‡	1‡	0‡
Name	Device control							
Type	R/W	R/W	R/W	R	R/W	R/W	R/W	R/W
Default	0	1	1	0	0	1	1	0

Register: **Device control**  
 Type: Read-only, Read/Write  
 Offset: 92h (Functions 0, 1)  
 Default: 66h  
 Description: This register is provided for PCI1130 compatibility. It contains bits which are shared between functions 0 and 1. The interrupt mode select is programmed through this register. The socket capable force bits are also programmed through this register.

**Table 41. Device Control Register Description**

BIT	TYPE	FUNCTION
7‡	R/W	Socket power lock bit. When this bit is set to 1, software will not be able to power down the PC Card socket while in D3. This may be necessary to support Wake on LAN or RING if the operating system is programmed to power down a socket when the CardBus controller is placed in the D3 state.
6‡§	R/W	3VCAPABLE. 3-V socket capable force bit. 0 = Not 3-V capable 1 = 3-V capable (default)
5‡	R/W	IO16R2. Diagnostic bit. This bit defaults to 1.
4	R	Reserved. This bit returns 0 when read. A write has no effect.
3‡§	R/W	TEST. TI test bit. Write only 0 to this bit. This bit can be set to shorten the interrogation counter.
2–1‡§	R/W	INTMODE. Interrupt mode. These bits select the interrupt signaling mode. The interrupt mode bits are encoded: 00 = Parallel PCI interrupts only 01 = Reserved 10 = IRQ serialized interrupts & parallel PCI interrupts $\overline{INTA}$ and $\overline{INTB}$ 11 = IRQ & PCI serialized interrupts (default)
0‡§	R/W	Reserved. NAND tree enable bit. There is a NAND tree diagnostic structure in the PCI4450, and it tests only the pins that are inputs or I/Os. Any output only terminal on the PCI4450 is excluded from the NAND tree test.

§ These bits are global in nature and should be accessed only through function 0.

‡ This bit is cleared only by the assertion of  $\overline{G\_RST}$ .

# PCI4450 GFN/GJG PC Card and OHCI Controller

SCPS046 – JANUARY 1999

## diagnostic register

Bit	7‡	6‡	5‡	4‡	3‡	2‡	1‡	0‡
Name	Diagnostic							
Type	R/W	R/W	R/W	R/W	R/W	R/W	R/W	R/W
Default	0	1	1	0	0	0	0	1

Register: **Diagnostic**  
 Type: Read/Write  
 Offset: 93h (Functions 0, 1)  
 Default: 61h  
 Description: This register is provided for internal Texas Instruments test purposes.

**Table 42. Diagnostic Register Description**

BIT	TYPE	FUNCTION
7‡§	R/W	This bit defaults to 0. This bit is encoded as: 0 = Reads true values in PCI vendor ID and PCI device ID registers (default). 1 = Reads all ones in reads to the PCI vendor ID and PCI device ID registers.
6‡	R/W	Reserved.
5‡	R/W	CSC interrupt routing control 0 = CSC interrupts routed to PCI if ExCA 803 bit 4 = 1. 1 = CSC Interrupts routed to PCI if ExCA 805 bits 7–4 = 0000b. (Default) In this case, the setting of ExCA 803 bit 4 is a “don’t care.”
4‡§	R/W	DIAG. Diagnostic RETRY_DIS. Delayed transaction disable.
3‡§	R/W	DIAG. Diagnostic RETRY_EXT. Extends the latency from 16 to 64.
2‡§	R/W	DIAG. Diagnostic DISCARD_TIM_SEL_CB. Set = 2 <sup>10</sup> , Reset = 2 <sup>15</sup>
1‡§	R/W	DIAG. Diagnostic DISCARD_TIM_SEL_PCI. Set = 2 <sup>10</sup> , Reset = 2 <sup>15</sup>
0‡§	R/W	ASYNC_CSC. Asynchronous interrupt generation. 0 = CSC interrupt not generated asynchronously 1 = CSC interrupt is generated asynchronously (default)

§ These bits are global in nature and should be accessed only through function 0.

‡ This bit is cleared only by the assertion of  $\overline{G\_RST}$ .



socket DMA register 0

Bit	31	30	29	28	27	26	25	24	23	22	21	20	19	18	17	16
Name	Socket DMA register 0															
Type	R	R	R	R	R	R	R	R	R	R	R	R	R	R	R	R
Default	0	0	0	0	0	0	0	0	0	0	0	0	0	0	0	0
Bit	15	14	13	12	11	10	9	8	7	6	5	4	3	2	1‡	0‡
Name	Socket DMA register 0															
Type	R	R	R	R	R	R	R	R	R	R	R	R	R	R	R/W	R/W
Default	0	0	0	0	0	0	0	0	0	0	0	0	0	0	0	0

Register: **DMA socket register 0**

Type: Read-only, Read/Write

Offset: 94h (Functions 0, 1)

Default: 0000 0000h

Description: This register provides control over the PC Card  $\overline{\text{DREQ}}$  (DMA request) signaling.

Table 43. Socket DMA Register 0 Description

BIT	TYPE	FUNCTION
31–2	R	Reserved. These bits return 0s when read.
1–0‡	R/W	DREQPIN. DMA request ( $\overline{\text{DREQ}}$ ) pin. These bits indicate which pin on the 16-bit PC Card interface will as the $\overline{\text{DREQ}}$ signal during DMA transfers. This field is encoded as: 00 = Socket not configured for DMA (default) 01 = $\overline{\text{DREQ}}$ uses $\overline{\text{SPKR}}$ 10 = $\overline{\text{DREQ}}$ uses $\overline{\text{IOIS16}}$ 11 = $\overline{\text{DREQ}}$ uses $\overline{\text{INPACK}}$

‡ This bit is cleared only by the assertion of  $\overline{\text{G\_RST}}$ .

# PCI4450 GFN/GJG PC Card and OHCI Controller

SCPS046 – JANUARY 1999

## socket DMA register 1

Bit	31	30	29	28	27	26	25	24	23	22	21	20	19	18	17	16
Name	Socket DMA register 1															
Type	R	R	R	R	R	R	R	R	R	R	R	R	R	R	R	R
Default	0	0	0	0	0	0	0	0	0	0	0	0	0	0	0	0
Bit	15‡	14‡	13‡	12‡	11‡	10‡	9‡	8‡	7‡	6‡	5‡	4‡	3‡	2‡	1‡	0‡
Name	Socket DMA register 1															
Type	R/W	R/W	R/W	R/W	R/W	R/W	R/W	R/W	R/W	R/W	R/W	R/W	R	R/W	R/W	R/W
Default	0	0	0	0	0	0	0	0	0	0	0	0	0	0	0	0

Register: **DMA socket register 1**

Type: Read-only, Read/Write

Offset: 98h (Functions 0, 1)

Default: 0000 0000h

Description: The contents of this register provide control over the distributed DMA (DDMA) registers and the PCI portion of DMA transfers. The DMA base address locates the DDMA registers in a 16-byte region within the first 64K bytes of PCI I/O address space. Note that 32-bit transfers to the 16-bit PC Card interface are not supported; the maximum transfer possible to the PC Card interface is 16-bits. However, 32 bits of data are prefetched from the PCI bus, thus allowing back-to-back 16-bit transfers to the PC Card interface.

**Table 44. Socket DMA Register 1 Description**

BIT	TYPE	FUNCTION
31–16	R	Reserved. These bits return 0s when read.
15–4‡	R/W	DMABASE. DMA base address. Locates the socket's DMA registers in PCI I/O space. This field represents a 16-bit PCI I/O address. The upper 16 bits of the address are hardwired to 0, forcing this window to within the lower 64K bytes of I/O address space. The lower four bits are hardwired to 0, and are included in the address decode. Thus, the window is aligned to a natural 16-byte boundary
3‡	R	EXTMODE. Extended addressing. This feature is not supported by the PCI4450, and always returns a 0.
2–1‡	R/W	XFERSIZE. Transfer size. These bits specify the width of the DMA transfer on the PC Card interface, and are encoded as: 00 = Transfers are 8 bits (default). 01 = Transfers are 16 bits. 10 = Reserved 11 = Reserved
0‡	R/W	DDMAEN. DDMA registers decode enable. Enables the decoding of the distributed DMA registers based upon the value of DMABASE. 0 = Disabled (default) 1 = Enabled

‡ This bit is cleared only by the assertion of  $\overline{G\_RST}$ .



**capability ID register**

Bit	7	6	5	4	3	2	1	0
Name	Capability ID							
Type	R	R	R	R	R	R	R	R
Default	0	0	0	0	0	0	0	1

Register: **Capability ID**

Type: Read-only

Offset: A0h

Default: 01h

Description: This register identifies the linked list item as the register for PCI power management. The register returns 01h when read, which is the unique ID assigned by the PCI SIG for the PCI location of the capabilities pointer and the value.

**next item pointer register**

Bit	7	6	5	4	3	2	1	0
Name	Next item pointer							
Type	R	R	R	R	R	R	R	R
Default	0	0	0	0	0	0	0	0

Register: **Next item pointer**

Type: Read-only

Offset: A1h

Default: 00h

Description: The contents of this register indicate the next item in the linked list of the PCI power management capabilities. Since the PCI4450 functions only include one capabilities item, this register returns 0s when read.

# PCI4450 GFN/GJG PC Card and OHCI Controller

SCPS046 – JANUARY 1999

## power management capabilities register

Bit	15†	14	13	12	11	10	9	8	7	6	5	4	3	2	1	0
Name	Power management capabilities															
Type	R/W	R	R	R	R	R	R	R	R	R	R	R	R	R	R	R
Default	1	1	1	1	1	1	1	0	0	0	0	1	0	0	0	1

Register: **Power management capabilities**

Type: Read-only, Read/Write

Offset: A2h (Functions 0, 1)

Default: FE11h

Description: This register contains information on the capabilities of the PC Card function related to power management. Both PCI4450 CardBus bridge functions support D0, D1, D2, and D3 power states.

**Table 45. Power Management Capabilities Register Description**

BIT	TYPE	FUNCTION
15†	R/W	PME support. This 5-bit field indicates the power states from which the PCI4450 device functions may assert $\overline{\text{PME}}$ . A 0b (zero) for any bit indicates that the function cannot assert the $\overline{\text{PME}}$ signal while in that power state. These five bits return 0Fh when read. Each of these bits is described below:  Bit 15 – defaults to a 1 indicating the $\overline{\text{PME}}$ signal can be asserted from the D3 <sub>cold</sub> state. This bit is read/write because wake-up support from D3 <sub>cold</sub> is contingent on the system providing an auxiliary power source to the V <sub>CC</sub> terminals. If the system designer chooses not to provide an auxiliary power source to the V <sub>CC</sub> terminals for D3 <sub>cold</sub> wake-up support, then BIOS should write a 0 to this bit.
14–11	R	Bit 14 – contains the value 1 to indicate that the $\overline{\text{PME}}$ signal can be asserted from the D3 <sub>hot</sub> state. Bit 13 – contains the value 1 to indicate that the $\overline{\text{PME}}$ signal can be asserted from the D2 state. Bit 12 – contains the value 1 to indicate that the $\overline{\text{PME}}$ signal can be asserted from the D1 state. Bit 11 – contains the value 1 to indicate that the $\overline{\text{PME}}$ signal can be asserted from the D0 state.
10	R	D2_Support. This bit returns a 1 when read, indicating that the function supports the D2 device power state.
9	R	D1_Support. This bit returns a 1 when read, indicating that the function supports the D1 device power state.
8–6	R	Reserved. These bits return 000b when read.
5	R	DSI. Device specific initialization. This bit returns 0 when read.
4	R	AUX_PWR. Auxiliary power source. This bit is meaningful only if bit 15 (D3 <sub>cold</sub> supporting $\overline{\text{PME}}$ ) is set. When this bit is set, it indicates that support for $\overline{\text{PME}}$ in D3 <sub>cold</sub> requires auxiliary power supplied by the system by way of a proprietary delivery vehicle. A 0 (zero) in this bit field indicates that the function supplies its own auxiliary power source. If the function does not support $\overline{\text{PME}}$ while in the D3 <sub>cold</sub> state (bit 15=0), then this field must always return 0.
3	R	PMECLK. When this bit is 1, it indicates that the function relies on the presence of the PCI clock for $\overline{\text{PME}}$ operation. When this bit is 0, it indicates that no PCI clock is required for the function to generate $\overline{\text{PME}}$ .  Functions that do not support $\overline{\text{PME}}$ generation in any state must return 0 for this field.
2–0	R	Version. These 3 bits return 001b when read, indicating that there are 4 bytes of general-purpose power management (PM) registers as described in the draft revision 1.0 <i>PCI Bus Power Management Interface Specification</i> .

† This bit is cleared only by the assertion of  $\overline{\text{G\_RST}}$  when  $\overline{\text{PME}}$  is enabled. If  $\overline{\text{PME}}$  is not enabled, then this bit is cleared by the assertion of  $\overline{\text{PRST}}$  or  $\overline{\text{G\_RST}}$ .



**power management control/status register**

Bit	15†	14	13	12	11	10	9	8†	7	6	5	4	3	2	1	0
Name	Power management control/status															
Type	R/WC	R	R	R	R	R	R	R/W	R	R	R	R	R	R	R/W	R/W
Default	0	0	0	0	0	0	0	0	0	0	0	0	0	0	0	0

Register: **Power management control/status**

Type: Read-only, Read/Write, Read/Write to Clear

Offset: A4h (Functions 0, 1)

Default: 000000h

Description: This register determines and changes the current power state of the PCI4450 CardBus function. The contents of this register are not affected by the internally generated reset caused by the transition from the D3<sub>hot</sub> to D0 state.

All PCI registers, ExCA registers, and CardBus registers are reset as a result of a D3<sub>hot</sub>-to-D0 state transition, with the exception of the PME context bits (if PME is enabled) and the G\_RST only bits.

**Table 46. Power Management Control/Status Register Description**

BIT	TYPE	FUNCTION
15†	R/WC	PMESTAT. PME status. This bit is set when the CardBus function would normally assert the $\overline{\text{PME}}$ signal, independent of the state of the PME_EN bit. This bit is cleared by a write back of 1, and this also clears the PME signal if $\overline{\text{PME}}$ was asserted by this function. Writing a 0 to this bit has no effect.
14–13	R	DATASCALE. This 2-bit field returns 0s when read. The CardBus function does not return any dynamic data, as indicated by the DYN_DATA bit.
12–9	R	DATASEL. Data select. This 4-bit field returns 0s when read. The CardBus function does not return any dynamic data, as indicated by the DYN_DATA bit.
8†	R/W	PME enable. This bit enables the function to assert $\overline{\text{PME}}$ . If this bit is cleared, then assertion of $\overline{\text{PME}}$ is disabled. This bit will not be cleared by the assertion of $\overline{\text{PRST}}$ . It will only be cleared by the assertion of $\overline{\text{G\_RST}}$ .
7–2	R	Reserved. These bits return 0s when read.
1–0	R/W	PWRSTATE. Power state. This 2-bit field is used both to determine the current power state of a function and to set the function into a new power state. This field is encoded as: 00 = D0 01 = D1 10 = D2 11 = D3 <sub>hot</sub>

† This bit is cleared only by the assertion of  $\overline{\text{G\_RST}}$  when  $\overline{\text{PME}}$  is enabled. If  $\overline{\text{PME}}$  is not enabled, then this bit is cleared by the assertion of  $\overline{\text{PRST}}$  or  $\overline{\text{G\_RST}}$ .

# PCI4450 GFN/GJG PC Card and OHCI Controller

SCPS046 – JANUARY 1999

## power management control/status register bridge support extensions

Bit	7	6	5	4	3	2	1	0
Name	Power management control/status register bridge support extensions							
Type	R	R	R	R	R	R	R	R
Default	1	1	0	0	0	0	0	0

Register: **Power management control/status register bridge support extensions**  
 Type: Read-only  
 Offset: A6h (Functions 0, 1)  
 Default: C0h  
 Description: This register supports PCI bridge specific functionality. It is required for all PCI-to-PCI bridges.

**Table 47. PMCSR\_BSE Bridge Support Extensions**

BIT	TYPE	FUNCTION
7	R	<p>BPCC_Enable. Bus power/clock control enable. This bit returns 1 when read. This bit is encoded as:            0 = Bus power/clock control is disabled.            1 = Bus power/clock control is enabled (default).</p> <p>A 0 indicates that the bus power/clock control policies defined in the PCI Power Management specification are disabled. When the bus power/clock control enable mechanism is disabled, the bridge's PMCSR powerstate field cannot be used by the system software to control the power or the clock of the bridge's secondary bus. A 1 indicates that the bus power/clock control mechanism is enabled. When bus power/clock control is disabled, the bridge's PMCSR power state field cannot be used by the system software to control power or the clock of the bridge's secondary bus.</p>
6	R	<p>B2_B3. B2/B3 support for D3<sub>hot</sub>. The state of this bit determines the action that is to occur as a direct result of programming the function to D3<sub>hot</sub>. This bit is only meaningful if bit 7 (BPCC_Enable) is a 1. This bit is encoded as:            0 = when the bridge is programmed to D3<sub>hot</sub>, its secondary bus will have its power removed (B3).            1 = when the bridge function is programmed to D3<sub>hot</sub>, its secondary bus's PCI clock will be stopped (B2).            (Default)</p>
5-0	R	Reserved. These bits return 0s when read.





**$\overline{\text{GPE}}$  control/status register**

Bit	15	14	13	12	11	10‡	9‡	8‡	7	6	5	4	3	2‡	1‡	0‡
Name	$\overline{\text{GPE}}$ control/status															
Type	R	R	R	R	R	R/WC	R/WC	R/WC	R	R	R	R	R	R/W	R/W	R/W
Default	0	0	0	0	0	0	0	0	0	0	0	0	0	0	0	0

Register:  **$\overline{\text{GPE}}$  control/status**

Type: Read-only, Read/Write, Read/Write to Clear

Offset: A8h

Default: 0001h

Description: If the  $\overline{\text{GPE}}$  (general-purpose event) function is programmed onto the MFUNC5 pin by writing 101b to bits 22–20 of the multifunction routing register (PCI offset 8Ch), then this register may be used to program which events will cause  $\overline{\text{GPE}}$  to be asserted and report the status.

**Table 48.  $\overline{\text{GPE}}$  Control/Status Register Description**

BIT	TYPE	FUNCTION
15–11	R	Reserved. These bits return 0s when read.
10‡	R/WC	ZV1_STS. PC Card socket 1 status. This bit is set on a change in status of the ZVENABLE bit in function 1.
9‡	R/WC	ZV0_STS. PC Card socket 0 status. This bit is set on a change in status of the ZVENABLE bit in function 0.
8‡	R/WC	VPP12_STS. 12-volt V <sub>pp</sub> request status. This bit is set when software has changed the requested V <sub>pp</sub> level to or from 12 volts from either socket.
7–3	R	Reserved. These bits return 0s when read.
2‡	R/W	ZV1_EN. PC Card socket 1 zoomed video event enable. When this bit is set, $\overline{\text{GPE}}$ is signaled on a change in status of the ZVENABLE bit in function 1 of the PC Card controller.
1‡	R/W	ZV0_EN. PC Card socket 0 zoomed video event enable. When this bit is set, $\overline{\text{GPE}}$ is signaled on a change in status of the ZVENABLE bit in function 0 of the PC Card controller.
0‡	R/W	VPP12_EN. 12 Volt V <sub>pp</sub> request event enable. When this bit is set, a $\overline{\text{GPE}}$ is signaled when software has changed the requested V <sub>pp</sub> level to or from 12 Volts for either socket.

‡ This bit is cleared only by the assertion of  $\overline{\text{G\_RST}}$ .

## ExCA compatibility registers (functions 0 and 1)

The ExCA (exchangeable card architecture) registers implemented in the PCI4450 are register-compatible with the Intel 82365SL-DF PCMCIA controller. ExCA registers are identified by an offset value, which is compatible with the legacy I/O index/data scheme used on the Intel 82365 ISA controller. The ExCA registers are accessed through this scheme by writing the register offset value into the index register (I/O base), and reading or writing the data register (I/O base + 1). The I/O base address used in the index/data scheme is programmed in the PC Card 16-bit I/F legacy mode base address register, which is shared by both card sockets. The offsets from this base address run contiguous from 00h to 3Fh for socket A, and from 40h to 7Fh for socket B. Refer to Figure 19 for an ExCA I/O mapping illustration. Table 49 identifies each ExCA register and its respective ExCA offset.

The TI PCI4450 also provides a memory mapped alias of the ExCA registers by directly mapping them into PCI memory space. They are located through the CardBus socket registers/ExCA registers base address register (PCI register 10h) at memory offset 800h. Each socket has a separate base address programmable by function. Refer to Figure 20 for an ExCA memory mapping illustration. Note that memory offsets are 800h–844h for both functions 0 and 1. This illustration also identifies the CardBus socket register mapping, which is mapped into the same 4K window at memory offset 0h.

The interrupt registers, as defined by the 82365SL Specification, in the ExCA register set control such card functions as reset, type, interrupt routing, and interrupt enables. Special attention must be paid to the interrupt routing registers and the host interrupt signaling method selected for the PCI4450 to ensure that all possible PCI4450 interrupts can potentially be routed to the programmable interrupt controller. The ExCA registers that are critical to the interrupt signaling are at memory address ExCA offset 803h and 805h.

Access to I/O mapped 16-bit PC Cards is available to the host system via two ExCA I/O windows. These are regions of host I/O address space into which the card I/O space is mapped. These windows are defined by start, end, and offset addresses programmed in the ExCA registers described in this section. I/O windows have byte granularity.

Access to memory mapped 16-bit PC Cards is available to the host system via five ExCA memory windows. These are regions of host memory space into which the card memory space is mapped. These windows are defined by start, end, and offset addresses programmed in the ExCA registers described in this section. Memory windows have 4K byte granularity.

A bit location followed by a  $\bar{\phantom{x}}$  means that this bit is not cleared by the assertion of  $\overline{\text{PRST}}$ . This bit will only be cleared by the assertion of  $\overline{\text{G\_RST}}$ . This is necessary to retain device context when transitioning from D3 to D0.

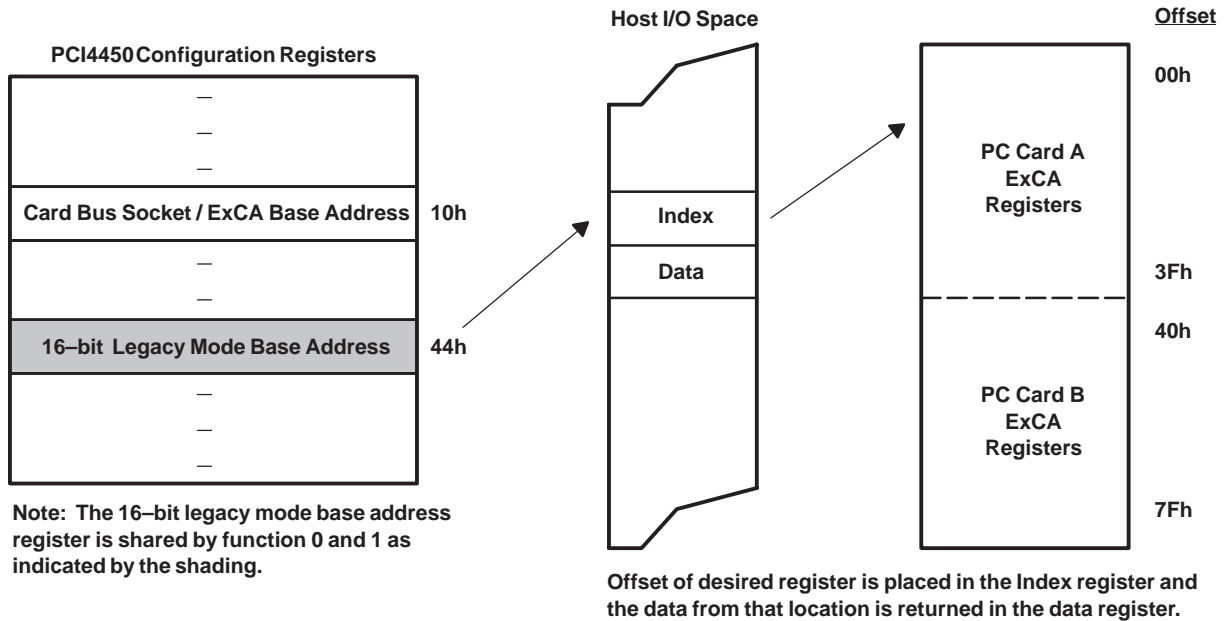

Figure 19. ExCA Register Access Through I/O

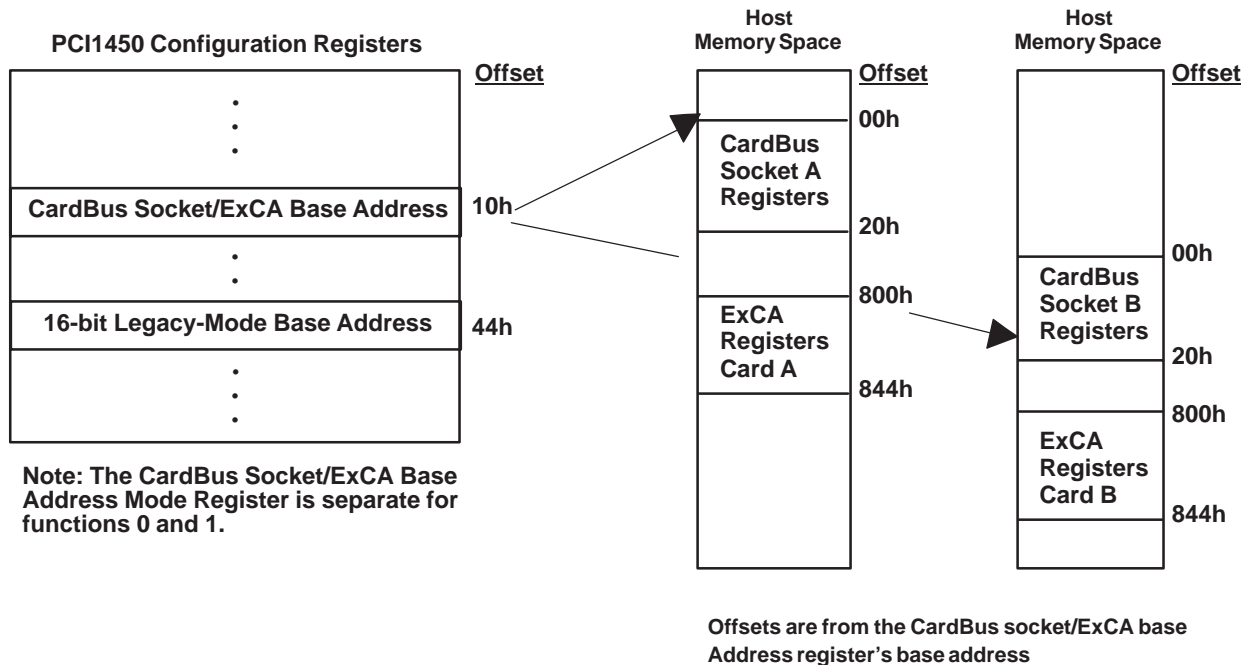

Figure 20. ExCA Register Access Through Memory

# PCI4450 GFN/GJG PC Card and OHCI Controller

SCPS046 – JANUARY 1999

**Table 49. ExCA Registers and Offsets**

REGISTER NAME	PCI MEMORY ADDRESS OFFSET	ExCA OFFSET (CARD A)	ExCA OFFSET (CARD B)
Identification and revision	800	00	40
Interface status	801	01	41
Power control †	802†	02	42
Interrupt and general control †	803†	03	43
Card status change †	804†	04	44
Card status change interrupt configuration †	805†	05	45
Address window enable	806	06	46
I / O window control	807	07	47
I / O window 0 start-address low-byte	808	08	48
I / O window 0 start-address high-byte	809	09	49
I / O window 0 end-address low-byte	80A	0A	4A
I / O window 0 end-address high-byte	80B	0B	4B
I / O window 1 start-address low-byte	80C	0C	4C
I / O window 1 start-address high-byte	80D	0D	4D
I / O window 1 end-address low-byte	80E	0E	4E
I / O window 1 end-address high-byte	80F	0F	4F
Memory window 0 start-address low-byte	810	10	50
Memory window 0 start-address high-byte	811	11	51
Memory window 0 end-address low-byte	812	12	52
Memory window 0 end-address high-byte	813	13	53
Memory window 0 offset-address low-byte	814	14	54
Memory window 0 offset-address high-byte	815	15	55
Card detect and general control	816	16	56
Reserved	817	17	57
Memory window 1 start-address low-byte	818	18	58
Memory window 1 start-address high-byte	819	19	59
Memory window 1 end-address low-byte	81A	1A	5A
Memory window 1 end-address high-byte	81B	1B	5B
Memory window 1 offset-address low-byte	81C	1C	5C
Memory window 1 offset-address high-byte	81D	1D	5D
Global control	81E	1E	5E
Reserved	81F	1F	5F
Memory window 2 start-address low-byte	820	20	60
Memory window 2 start-address high-byte	821	21	61
Memory window 2 end-address low-byte	822	22	62
Memory window 2 end-address high-byte	823	23	63
Memory window 2 offset-address low-byte	824	24	64
Memory window 2 offset-address high-byte	825	25	65
Reserved	826	26	66
Reserved	827	27	67

† One or more bits in this register are cleared only by the assertion of G\_RST when PME is enabled. If PME is NOT enabled, then this bit is cleared by the assertion of PRST or G\_RST.



**Table 49. ExCA Registers and Offsets (continued)**

REGISTER NAME	PCI MEMORY ADDRESS OFFSET	ExCA OFFSET (CARD A)	ExCA OFFSET (CARD B)
Memory window 3 start-address low-byte	828	28	68
Memory window 3 start-address high-byte	829	29	69
Memory window 3 end-address low-byte	82A	2A	6A
Memory window 3 end-address high-byte	82B	2B	6B
Memory window 3 offset-address low-byte	82C	2C	6C
Memory window 3 offset-address high-byte	82D	2D	6D
Reserved	82E	2E	6E
Reserved	82F	2F	6F
Memory window 4 start-address low-byte	830	30	70
Memory window 4 start-address high-byte	831	31	71
Memory window 4 end-address low-byte	832	32	72
Memory window 4 end-address high-byte	833	33	73
Memory window 4 offset-address low-byte	834	34	74
Memory window 4 offset-address high-byte	835	35	75
I/O window 0 offset-address low-byte	836	36	76
I/O window 0 offset-address high-byte	837	37	77
I/O window 1 offset-address low-byte	838	38	78
I/O window 1 offset-address high-byte	839	39	79
Reserved	83A	3A	7A
Reserved	83B	3B	7B
Reserved	83C	3C	7C
Reserved	83D	3D	7D
Reserved	83E	3E	7E
Reserved	83F	3F	7F
Memory window page register 0	840	-	-
Memory window page register 1	841	-	-
Memory window page register 2	842	-	-
Memory window page register 3	843	-	-
Memory window page register 4	844	-	-

# PCI4450 GFN/GJG PC Card and OHCI Controller

SCPS046 – JANUARY 1999

## ExCA identification and revision register (Index 00h)

Bit	7	6	5	4	3	2	1	0
Name	ExCA identification and revision							
Type	R/W	R/W	R/W	R/W	R/W	R/W	R/W	R/W
Default	1	0	0	0	0	1	0	0

Register: **ExCA identification and revision**

Type: Read/Write

Offset: CardBus Socket Address + 800h:      Card A ExCA Offset 00h  
    Card B ExCA Offset 40h

Default: 84h

Description: This register provides host software with information on 16-bit PC Card support and 82365SL-DF compatibility.

NOTE: If bit 5 (SUBSYRW) in the system control register is 1, then this register is read-only.

**Table 50. ExCA Identification and Revision Register Description**

BIT	TYPE	FUNCTION
7-6	R/W	IFTYPE. Interface type. These bits, which are hardwired as 10b, identify the 16-bit PC Card support provided by the PCI4450. The PCI4450 supports both I/O and memory 16-bit PC Cards.
5-4	R/W	Reserved. These bits can be used for 82365SL emulation.
3-0	R/W	365REV. 82365SL revision. This field stores the 82365SL revision supported by the PCI4450. Host software may read this field to determine compatibility to the 82365SL register set. This field defaults to 0100b upon reset.



**ExCA interface status register (Index 01h)**

Bit	7	6	5	4	3	2	1	0
Name	ExCA interface status							
Type	R	R	R	R	R	R	R	R
Default	0	0	x	x	x	x	x	x

Register: **ExCA interface status**

Type: Read-only

Offset: CardBus Socket Address + 801h: Card A ExCA Offset 01h  
Card B ExCA Offset 41h

Default: 00XX XXXXb

Description: This register provides information on current status of the PC Card interface. An x in the default bit values indicates that the value of the bit after reset depends on the state of the PC Card interface.

**Table 51. ExCA Interface Status Register Description**

BIT	TYPE	FUNCTION
7	R	Reserved. This bit returns 0 when read. A write has no effect.
6	R	CARDPWR. Card power. This bit indicates the current power status of the PC Card socket. This bit reflects how the ExCA power control register has been programmed. The bit is encoded as: 0 = V <sub>CC</sub> and V <sub>PP</sub> to the socket is turned off (default). 1 = V <sub>CC</sub> and V <sub>PP</sub> to the socket is turned on.
5	R	READY. This bit indicates the current status of the READY signal at the PC Card interface. 0 = PC Card is not ready for a data transfer. 1 = PC Card is ready for a data transfer.
4	R	CARDWP. Card write protect. This bit indicates the current status of the WP signal at the PC Card interface. This signal reports to the PCI4450 whether or not the memory card is write protected. Further, write protection for an entire PCI4450 16-bit memory window is available by setting the appropriate bit in the ExCA memory window offset-address high byte register. 0 = WP signal is 0. PC Card is R/W. 1 = WP signal is 1. PC Card is read-only.
3	R	CDETECT2. Card detect 2. This bit indicates the status of the CD2 signal at the PC Card interface. Software may use this and CDETECT1 to determine if a PC Card is fully seated in the socket. 0 = CD2 signal is 1. No PC Card inserted. 1 = CD2 signal is 0. PC Card at least partially inserted.
2	R	CDETECT1. Card detect 1. This bit indicates the status of the CD1 signal at the PC Card interface. Software may use this and CDETECT2 to determine if a PC Card is fully seated in the socket. 0 = CD1 signal is 1. No PC Card inserted. 1 = CD1 signal is 0. PC Card at least partially inserted.
1–0	R	BVDSTAT. Battery voltage detect. When a 16-bit memory card is inserted, the field indicates the status of the battery voltage detect signals (BVD1, BVD2) at the PC Card interface, where bit 0 reflects the BVD1 status, and bit 1 reflects BVD2. 00 = Battery is dead. 01 = Battery is dead. 10 = Battery is low; warning. 11 = Battery is good.  When a 16-bit I/O card is inserted, this field indicates the status of the $\overline{\text{SPKR}}$ (bit 1) signal and the $\overline{\text{STSCHG}}$ (bit 0) at the PC Card interface. In this case, the two bits in this field directly reflect the current state of these card outputs.

# PCI4450 GFN/GJG PC Card and OHCI Controller

SCPS046 – JANUARY 1999

## ExCA power control register (Index 02h)

Bit	7	6	5	4†	3†	2	1†	0†
Name	ExCA power control							
Type	R/W	R	R	R/W	R/W	R	R/W	R/W
Default	0	0	0	0	0	0	0	0

Register: **ExCA power control**  
 Type: Read-only, Read/Write  
 Offset: CardBus Socket Address + 802h: Card A ExCA Offset 02h  
 Card B ExCA Offset 42h

Default: 00h

Description: This register provides PC Card power control. Bit 7 of this register controls the 16-bit output enables on the socket interface, and can be used for power management in 16-bit PC Card applications.

**Table 52. ExCA Power Control Register Description**

BIT	TYPE	FUNCTION
7†	R/W	COE. Card output enable. This bit controls the state of all of the 16-bit outputs on the PCI4450. This bit is encoded as: 0 = 16-bit PC Card outputs are disabled (default). 1 = 16-bit PC Card outputs are enabled.
6–5	R	Reserved. These bits return 0s when read. Writes have no effect.
4–3†	R/W	EXCAVCC. V <sub>CC</sub> . These bits are used to request changes to card V <sub>CC</sub> . This field is encoded as: 00 = 0 V (default) 01 = 0 V Reserved 10 = 5 V 11 = 3 V
2	R	Reserved. This bit returns 0 when read. A write has no effect.
1–0†	R/W	EXCAVPP. V <sub>pp</sub> . These bits are used to request changes to card V <sub>pp</sub> . The PCI4450 ignores this field unless V <sub>CC</sub> to the socket is enabled (i.e., 5 Vdc or 3.3 Vdc). This field is encoded as: 00 = 0 V (default) 01 = V <sub>CC</sub> 10 = 12 V 11 = 0 V Reserved

† This bit is cleared only by the assertion of  $\overline{G\_RST}$  when  $\overline{PME}$  is enabled. If  $\overline{PME}$  is not enabled, then this bit is cleared by the assertion of  $\overline{PRST}$  or  $\overline{G\_RST}$ .



**ExCA interrupt and general control register (Index 03h)**

Bit	7	6†	5†	4	3	2	1	0
Name	ExCA interrupt and general control							
Type	R/W	R/W	R/W	R/W	R/W	R/W	R/W	R/W
Default	0	0	0	0	0	0	0	0

Register: **ExCA interrupt and general control**

Type: Read/Write

Offset: CardBus Socket Address + 803h: Card A ExCA Offset 03h  
Card B ExCA Offset 43h

Default: 00h

Description: This register controls interrupt routing for I/O interrupts as well as other critical 16-bit PC Card functions.

**Table 53. ExCA Interrupt and General Control Register Description**

BIT	TYPE	FUNCTION
7	R/W	RINGEN. Card ring indicate enable. Enables the ring indicate function of the BVD1/RI pins. This bit is encoded as: 0 = Ring indicate disabled (default) 1 = Ring indicate enabled
6†	R/W	Card reset. This bit controls the 16-bit PC Card RESET signal, and allows host software to force a card reset. This bit affects 16-bit cards only. This bit is encoded as: 0 = RESET signal asserted (default) 1 = RESET signal deasserted.
5†	R/W	CARDTYPE. Card type. This bit indicates the PC Card type. This bit is encoded as: 0 = Memory PC Card is installed (default) 1 = I/O PC Card is installed
4	R/W	CSCROUTE. PCI interrupt – CSC routing enable bit. This bit has meaning only if the CSC interrupt routing control bit (PCI offset 93h, bit 5) is 0b. In this case, when this bit is set (high), the card status change interrupts are routed to PCI interrupts. When low the card status change interrupts are routed, using bits 7–4 in the ExCA card status change interrupt configuration register. This bit is encoded as: 0 = CSC interrupts routed by ExCA registers (default) 1 = CSC interrupts routed to PCI interrupts If the CSC interrupt routing control bit (PCI offset 93h, bit 5) is set to 1b, this bit has no meaning which is the default case.
3–0	R/W	INTSELECT. Card interrupt select for I/O PC Card functional interrupts. These bits select the interrupt routing for I/O PC Card functional interrupts. This field is encoded as: 0000 = No ISA interrupt routing (default). CSC interrupts routed to PCI Interrupts. 0001 = IRQ1 enabled 0010 = SMI enabled 0011 = IRQ3 enabled 0100 = IRQ4 enabled 0101 = IRQ5 enabled 0110 = IRQ6 enabled 0111 = IRQ7 enabled 1000 = IRQ8 enabled 1001 = IRQ9 enabled 1010 = IRQ10 enabled 1011 = IRQ11 enabled 1100 = IRQ12 enabled 1101 = IRQ13 enabled 1110 = IRQ14 enabled 1111 = IRQ15 enabled

† This bit is cleared only by the assertion of  $\overline{G\_RST}$  when  $\overline{PME}$  is enabled. If  $\overline{PME}$  is not enabled, then this bit is cleared by the assertion of  $\overline{PRST}$  or  $\overline{G\_RST}$ .

# PCI4450 GFN/GJG PC Card and OHCI Controller

SCPS046 – JANUARY 1999

## ExCA card status-change register (Index 04h)

Bit	7	6	5	4	3†	2†	1†	0†
Name	ExCA card status-change							
Type	R	R	R	R	R	R	R	R
Default	0	0	0	0	0	0	0	0

Register: **ExCA card status-change**

Type: Read-only

Offset: CardBus Socket Address + 804h: Card A ExCA Offset 04h  
Card B ExCA Offset 44h

Default: 00h

Description: This register reflects the status of PC Card CSC interrupt sources. The ExCA card status change interrupt configuration register enables these interrupt sources to generate an interrupt to the host. When the interrupt source is disabled, the corresponding bit in this register always reads as 0. When an interrupt source is enabled and that particular event occurs, the corresponding bit in this register is set to indicate the interrupt source. After generating the interrupt to the host, the interrupt service routine must read this register to determine the source of the interrupt. The interrupt service routine is responsible for resetting the bits in this register, as well. Resetting a bit is accomplished by one of two methods: a read of this register, or an explicit write back of 1 to the status bit. The choice of these two methods is based on the interrupt flag clear mode select, bit 2, in the ExCA global control register.

**Table 54. ExCA Card Status-Change Register Description**

BIT	TYPE	FUNCTION
7–4	R	Reserved. These bits return 0s when read. Writes have no effect.
3†	R	CDCHANGE. Card detect change. This bit indicates whether a change on the CD1 or CD2 signals occurred at the PC Card interface. A read of this bit or writing a 1 to this bit clears it. This bit is encoded as: 0 = No change detected on either CD1 or CD2 1 = A change was detected on either CD1 or CD2
2†	R	READYCHANGE. Ready change. When a 16-bit memory is installed in the socket, this bit includes whether the source of a PCI4450 interrupt was due to a change on the READY signal at the PC Card interface indicating that PC Card is now ready to accept new data. A read of this bit or writing a 1 to this bit clears it. This bit is encoded as: 0 = No low-to-high transition detected on READY (default) 1 = Detected a low-to-high transition on READY When a 16-bit I/O card is installed, this bit is always 0.
1†	R	BATWARN. Battery warning change. When a 16-bit memory card is installed in the socket, this bit indicates whether the source of a PCI4450 interrupt was due to a battery low warning condition. A read of this bit or writing a 1 to this bit clears it. This bit is encoded as: 0 = No battery warning condition (default) 1 = Detected a battery warning condition When a 16-bit I/O card is installed, this bit is always 0.
0†	R	BATDEAD. Battery dead or status change. When a 16-bit memory card is installed in the socket, this bit indicates whether the source of a PCI4450 interrupt was due to a battery dead condition. A read of this bit or writing a 1 to this bit clears it. This bit is encoded as: 0 = STSCHG deasserted (default) 1 = STSCHG asserted Ring indicate. When the PCI4450 is configured for ring indicate operation this bit indicates the status of the RI pin.

† This bit is cleared only by the assertion of  $\overline{G\_RST}$  when  $\overline{PME}$  is enabled. If  $\overline{PME}$  is not enabled, then this bit is cleared by the assertion of  $\overline{PRST}$  or  $\overline{G\_RST}$ .



**ExCA card status-change interrupt configuration register (Index 05h)**

Bit	7	6	5	4	3†	2†	1†	0†
Name	ExCA card status-change interrupt configuration							
Type	R/W	R/W	R/W	R/W	R/W	R/W	R/W	R/W
Default	0	0	0	0	0	0	0	0

Register: **ExCA card status-change interrupt configuration**

Type: Read/Write

Offset: CardBus Socket Address + 805h: Card A ExCA Offset 05h  
Card B ExCA Offset 45h

Default: 00h

Description: This register controls interrupt routing for CSC interrupts, as well as masks/unmasks CSC interrupt sources.

**Table 55. ExCA Card Status-Change Interrupt Register Description**

BIT	TYPE	FUNCTION
7–4	R/W	CSCSELECT. Interrupt select for card status change. These bits select the interrupt routing for card status change interrupts. This field is encoded as: 0000 = CSC interrupts routed to PCI interrupts if bit 5 of the diagnostic register (PCI offset 93h) is set to 1b. In this case bit 4 of ExCA 803 is a “don’t care.” This is the default setting. 0000 = No ISA interrupt routing if bit 5 of the diagnostic register (PCI offset 93h) is set to 0b. In this case, CSC interrupts are routed to PCI interrupts by setting bit 4 of ExCA 803h to 1b 0001 = IRQ1 enabled 0010 = SMI enabled 0011 = IRQ3 enabled 0100 = IRQ4 enabled 0101 = IRQ5 enabled 0110 = IRQ6 enabled 0111 = IRQ7 enabled 1000 = IRQ8 enabled 1001 = IRQ9 enabled 1010 = IRQ10 enabled 1011 = IRQ11 enabled 1100 = IRQ12 enabled 1101 = IRQ13 enabled 1110 = IRQ14 enabled 1111 = IRQ15 enabled
3†	R/W	CDEN. Card detect enable. Enables interrupts on CD1 or CD2 changes. This bit is encoded as: 0 = Disables interrupts on CD1 or CD2 line changes (default) 1 = Enable interrupts on CD1 or CD2 line changes
2†	R/W	READYEN. Ready enable. This bit enables/disables a low-to-high transition on the PC Card READY signal to generate a host interrupt. This interrupt source is considered a card status change. This bit is encoded as: 0 = Disables host interrupt generation (default) 1 = Enables host interrupt generation
1†	R/W	BATWARNEN. Battery warning enable. This bit enables/disables a battery warning condition to generate a CSC interrupt. This bit is encoded as: 0 = Disables host interrupt generation (default) 1 = Enables host interrupt generation
0†	R/W	BATDEADEN. Battery dead enable. This bit enables/disables a battery dead condition on a memory PC Card or assertion of the STSCHG I/O PC Card signal to generate a CSC interrupt. 0 = Disables host interrupt generation (default) 1 = Enables host interrupt generation

† This bit is cleared only by the assertion of  $\overline{G\_RST}$  when  $\overline{PME}$  is enabled. If  $\overline{PME}$  is not enabled, then this bit is cleared by the assertion of  $\overline{PRST}$  or  $\overline{G\_RST}$ .

# PCI4450 GFN/GJG

## PC Card and OHCI Controller

SCPS046 – JANUARY 1999

### ExCA address window enable register (Index 06h)

Bit	7	6	5	4	3	2	1	0
Name	ExCA address window enable							
Type	R/W	R/W	R	R/W	R/W	R/W	R/W	R/W
Default	0	0	0	0	0	0	0	0

Register: **ExCA address window enable**

Type: Read-only, Read/Write

Offset: CardBus Socket Address + 806h: Card A ExCA Offset 06h  
Card B ExCA Offset 46h

Default: 00h

Description: This register enables/disables the memory and I/O windows to the 16-bit PC Card. By default, all windows to the card are disabled. The PCI4450 will not acknowledge PCI memory or I/O cycles to the card if the corresponding enable bit in this register is 0, regardless of the programming of the ExCA memory and I/O window start/end/offset address registers.

**Table 56. ExCA Address Window Enable Register Description**

BIT	TYPE	FUNCTION
7	R/W	IOWIN1EN. I/O window 1 enable. This bit enables/disables I/O window 1 for the card. This bit is encoded as: 0 = I/O window 1 disabled (default) 1 = I/O window 1 enabled
6	R/W	IOWIN0EN. I/O window 0 enable. This bit enables/disables I/O window 0 for the card. This bit is encoded as: 0 = I/O window 0 disabled (default) 1 = I/O window 0 enabled
5	R	Reserved. This bit returns 0 when read. A write has no effect.
4	R/W	MEMWIN4EN. Memory window 4 enable. This bit enables/disables memory window 4 for the card. This bit is encoded as: 0 = memory window 4 disabled (default) 1 = memory window 4 enabled
3	R/W	MEMWIN3EN. Memory window 3 enable. This bit enables/disables memory window 3 for the card. This bit is encoded as: 0 = memory window 3 disabled (default) 1 = memory window 3 enabled
2	R/W	MEMWIN2EN. Memory window 2 enable. This bit enables/disables memory window 2 for the card. This bit is encoded as: 0 = memory window 2 disabled (default) 1 = memory window 2 enable
1	R/W	MEMWIN1EN. Memory window 1 enable. This bit enables/disables memory window 1 for the PC Card. This bit is encoded as: 0 = memory window 1 disabled (default) 1 = memory window 1 enabled
0	R/W	MEMWIN0EN. Memory window 0 enable. This bit enables/disables memory window 0 for the PC Card. This bit is encoded as: 0 = memory window 0 disabled (default) 1 = memory window 0 enabled



**ExCA I/O window control register (Index 07h)**

Bit	7	6	5	4	3	2	1	0
Name	ExCA I/O window control							
Type	R/W	R/W	R/W	R/W	R/W	R/W	R/W	R/W
Default	0	0	0	0	0	0	0	0

Register: **ExCA I/O window control**  
 Type: Read/Write  
 Offset: CardBus Socket Address + 807h: Card A ExCA Offset 07h  
 Card B ExCA Offset 47h  
 Default: 00h  
 Description: This register contains parameters related to I/O window sizing and cycle timing.

**Table 57. ExCA I/O Window Control Register Description**

BIT	TYPE	FUNCTION
7	R/W	WAITSTATE1. I/O window 1 wait-state. This bit controls the I/O window 1 wait-state for 16-bit I/O accesses. This bit has no effect on 8-bit accesses. This wait-state timing emulates the ISA wait-state used by the 82365SL-DF. This bit is encoded as: 0 = 16-bit cycles have standard length (default) 1 = 16-bit cycles extended by one equivalent ISA wait state
6	R/W	ZEROWS1. I/O window 1 zero wait-state. This bit controls the I/O window 1 wait-state for 8-bit I/O accesses. NOTE: This bit has no effect on 16-bit accesses. This wait-state timing emulates the ISA wait-state used by the 82365SL-DF. 0 = 8-bit cycles have standard length (default) 1 = 8-bit cycles reduced to equivalent of three ISA cycles
5	R/W	IOIS16W1. I/O window 1 IOIS16 source. This bit controls the I/O window automatic data sizing feature which used the IOIS16 signal from the PC Card to determine the data width of the I/O data transfer. 0 = Data width determined by DATASIZE1, bit 4 (default) 1 = Window data width determined by IOIS16
4	R/W	DATASIZE1. I/O window 1 data size. This bit controls the I/O window 1 data size. This bit is ignored if the I/O window 1 IOIS16 source bit (bit 5) is set. This bit is encoded as: 0 = Window data width is 8 bits (default) 1 = Window data width is 16 bits
3	R/W	WAITSTATE0. I/O window 0 wait-state. This bit controls the I/O window 0 wait-state for 16-bit I/O accesses. This bit has no effect on 8-bit accesses. This wait-state timing emulates the ISA wait-state used by the 82365SL-DF. This bit is encoded as: 0 = 16-bit cycles have standard length (default) 1 = 16-bit cycles extended by one equivalent ISA wait state
2	R/W	ZEROWS0. I/O window 0 zero wait-state. This bit controls the I/O window 0 wait-state for 8-bit I/O accesses. NOTE: This bit has no effect on 16-bit accesses. This wait-state timing emulates the ISA wait-state used by the 82365SL-DF. 0 = 8-bit cycles have standard length (default) 1 = 8-bit cycles reduced to equivalent of three ISA cycles
1	R/W	IOIS16W0. I/O window 0 IOIS16 source. This bit controls the I/O window automatic data sizing feature which used the IOIS16 signal from the PC Card to determine the data width of the I/O data transfer. 0 = Data width determined by DATASIZE0, bit 0 (default) 1 = Window data width determined by IOIS16
0	R/W	DATASIZE0. I/O window 0 data size. This bit controls the I/O window 1 data size. This bit is ignored if the I/O window 1 IOIS16 Source bit (bit 1) is set. This bit is encoded as: 0 = Window data width is 8 bits (default) 1 = Window data width is 16 bits

# PCI4450 GFN/GJG PC Card and OHCI Controller

SCPS046 – JANUARY 1999

## ExCA I/O window 0 & 1 start-address low-byte register (Index 08h, 0Ch)

Bit	7	6	5	4	3	2	1	0
<b>Name</b>	ExCA I/O window 0 & 1 start-address low-byte							
<b>Type</b>	R/W	R/W	R/W	R/W	R/W	R/W	R/W	R/W
<b>Default</b>	0	0	0	0	0	0	0	0

Register: **ExCA I/O window 0 start-address low-byte**

Offset: CardBus Socket Address + 808h: Card A ExCA Offset 08h  
Card B ExCA Offset 48h

Register: **ExCA I/O window 1 start-address low-byte**

Offset: CardBus Socket Address + 80Ch: Card A ExCA Offset 0Ch  
Card B ExCA Offset 4Ch

Type: Read/Write

Default: 00h

Size: One byte

Description: These registers contain the low-byte of the 16-bit I/O window start address for I/O windows 0 and 1. The 8 bits of these registers correspond to the lower 8 bits of the start address.

## ExCA I/O window 0 & 1 start-address high-byte register (Index 09h, 0Dh)

Bit	7	6	5	4	3	2	1	0
<b>Name</b>	ExCA I/O window 0 & 1 start-address high-byte							
<b>Type</b>	R/W	R/W	R/W	R/W	R/W	R/W	R/W	R/W
<b>Default</b>	0	0	0	0	0	0	0	0

Register: **ExCA I/O window 0 start-address high-byte**

Offset: CardBus Socket Address + 809h: Card A ExCA Offset 09h  
Card B ExCA Offset 49h

Register: **ExCA I/O window 1 start-address high-byte**

Offset: CardBus Socket Address + 80Dh: Card A ExCA Offset 0Dh  
Card B ExCA Offset 4Dh

Type: Read/Write

Default: 00h

Size: One byte

Description: These registers contain the high-byte of the 16-bit I/O window start address for I/O windows 0 and 1. The 8 bits of these registers correspond to the upper 8 bits of the start address.



**ExCA I/O window 0 & 1 end-address low-byte register (Index 0Ah, 0Eh)**

Bit	7	6	5	4	3	2	1	0
Name	ExCA I/O window 0 & 1 end-address low-byte							
Type	R/W	R/W	R/W	R/W	R/W	R/W	R/W	R/W
Default	0	0	0	0	0	0	0	0

Register: **ExCA I/O window 0 end-address low-byte**  
 Offset: CardBus Socket Address + 80Ah: Card A ExCA Offset 0Ah  
 Card B ExCA Offset 4Ah

Register: **ExCA I/O window 1 end-address low-byte**  
 Offset: CardBus Socket Address + 80Eh: Card A ExCA Offset 0Eh  
 Card B ExCA Offset 4Eh

Type: Read/Write  
 Default: 00h  
 Size: One byte  
 Description: These registers contain the low-byte of the 16-bit I/O window end address for I/O windows 0 and 1. The 8 bits of these registers correspond to the lower 8 bits of the start address.

**ExCA I/O window 0 & 1 end-address high-byte register (Index 0Bh, 0Fh)**

Bit	7	6	5	4	3	2	1	0
Name	ExCA I/O window 0 & 1 end-address high-byte							
Type	R/W	R/W	R/W	R/W	R/W	R/W	R/W	R/W
Default	0	0	0	0	0	0	0	0

Register: **ExCA I/O window 0 end-address high-byte**  
 Offset: CardBus Socket Address + 80Bh: Card A ExCA Offset 0Bh  
 Card B ExCA Offset 4Bh

Register: **ExCA I/O window 1 end-address high-byte**  
 Offset: CardBus Socket Address + 80Fh: Card A ExCA Offset 0Fh  
 Card B ExCA Offset 4Fh

Type: Read/Write  
 Default: 00h  
 Size: One byte  
 Description: These registers contain the high-byte of the 16-bit I/O window end address for I/O windows 0 and 1. The eight bits of these registers correspond to the upper eight bits of the end address.

# PCI4450 GFN/GJG PC Card and OHCI Controller

SCPS046 – JANUARY 1999

## ExCA memory window 0–4 start-address low-byte register (Index 10h/18h/20h/28h/30h)

Bit	7	6	5	4	3	2	1	0
<b>Name</b>	ExCA memory window 0–4 start-address low-byte							
<b>Type</b>	R/W	R/W	R/W	R/W	R/W	R/W	R/W	R/W
<b>Default</b>	0	0	0	0	0	0	0	0

Register: **ExCA memory window 0 start-address low-byte**

Offset: CardBus Socket Address + 810h: Card A ExCA Offset 10h  
Card B ExCA Offset 50h

Register: **ExCA memory window 1 start-address low-byte**

Offset: CardBus Socket Address + 818h: Card A ExCA Offset 18h  
Card B ExCA Offset 58h

Register: **ExCA memory window 2 start-address low-byte**

Offset: CardBus Socket Address + 820h: Card A ExCA Offset 20h  
Card B ExCA Offset 60h

Register: **ExCA memory window 3 start-address low-byte**

Offset: CardBus Socket Address + 828h: Card A ExCA Offset 28h  
Card B ExCA Offset 68h

Register: **ExCA memory window 4 start-address low-byte**

Offset: CardBus Socket Address + 830h: Card A ExCA Offset 30h  
Card B ExCA Offset 70h

Type: Read/Write

Default: 00h

Size: One byte

Description: These registers contain the low-byte of the 16-bit memory window start address for memory windows 0, 1, 2, 3, and 4. The 8 bits of these registers correspond to bits A19–A12 of the start address.





**ExCA memory window 0–4 start-address high-byte register (Index 11h/19h/21h/29h/31h)**

<b>Bit</b>	<b>7</b>	<b>6</b>	<b>5</b>	<b>4</b>	<b>3</b>	<b>2</b>	<b>1</b>	<b>0</b>
<b>Name</b>	ExCA memory window 0–4 start-address high-byte							
<b>Type</b>	R/W	R/W	R/W	R/W	R/W	R/W	R/W	R/W
<b>Default</b>	0	0	0	0	0	0	0	0

Register: **ExCA memory window 0 start-address high-byte**

Offset: CardBus Socket Address + 811h: Card A ExCA Offset 11h  
Card B ExCA Offset 51h

Register: **ExCA memory window 1 start-address high-byte**

Offset: CardBus Socket Address + 819h: Card A ExCA Offset 19h  
Card B ExCA Offset 59h

Register: **ExCA memory window 2 start-address high-byte**

Offset: CardBus Socket Address + 821h: Card A ExCA Offset 21h  
Card B ExCA Offset 61h

Register: **ExCA memory window 3 start-address high-byte**

Offset: CardBus Socket Address + 829h: Card A ExCA Offset 29h  
Card B ExCA Offset 69h

Register: **ExCA memory window 4 start-address high-byte**

Offset: CardBus Socket Address + 831h: Card A ExCA Offset 31h  
Card B ExCA Offset 71h

Type: Read/Write

Default: 00h

Size: One byte

Description: These registers contain the high-nibble of the 16-bit memory window start address for memory windows 0, 1, 2, 3, and 4. The lower 4 bits of these registers correspond to bits A23–A20 of the start address. In addition, the memory window data width and wait states are set in this register.

**Table 58. ExCA Memory Window 0–4 Start-Address High-Byte Register Description**

<b>BIT</b>	<b>TYPE</b>	<b>FUNCTION</b>
7	R/W	DATASIZE. This bit controls the memory window data width. This bit is encoded as: 0 = Window data width is 8 bits (default) 1 = Window data width is 16 bits
6	R/W	ZEROWAIT. Zero wait-state. This bit controls the memory window wait state for 8- and 16-bit accesses. This wait state timing emulates the ISA wait-state used by the 82365SL-DF. This bit is encoded as: 0 = 8- and 16-bit cycles have standard length (default) 1 = 8-bit cycles reduced to equivalent of three ISA cycles 16-bit cycles reduce to the equivalent of two ISA cycles.
5–4	R/W	SCRATCH. Scratch pad bits. These bits have no effect on memory window operation.
3–0	R/W	STAHN. Start address high-nibble. These bits represent the upper address bits A23–A20 of the memory window start address.

# PCI4450 GFN/GJG PC Card and OHCI Controller

SCPS046 – JANUARY 1999

## ExCA memory window 0–4 end-address low-byte register (Index 12h/1Ah/22h/2Ah/32h)

Bit	7	6	5	4	3	2	1	0
<b>Name</b>	ExCA memory window 0–4 end-address low-byte							
<b>Type</b>	R/W	R/W	R/W	R/W	R/W	R/W	R/W	R/W
<b>Default</b>	0	0	0	0	0	0	0	0

Register: **ExCA memory window 0 end-address low-byte**

Offset: CardBus Socket Address + 812h: Card A ExCA Offset 12h  
Card B ExCA Offset 52h

Register: **ExCA memory window 1 end-address low-byte**

Offset: CardBus Socket Address + 81Ah: Card A ExCA Offset 1Ah  
Card B ExCA Offset 5Ah

Register: **ExCA memory window 2 end-address low-byte**

Offset: CardBus Socket Address + 822h: Card A ExCA Offset 22h  
Card B ExCA Offset 62h

Register: **ExCA memory window 3 end-address low-byte**

Offset: CardBus Socket Address + 82Ah: Card A ExCA Offset 2Ah  
Card B ExCA Offset 68h

Register: **ExCA memory window 4 end-address low-byte**

Offset: CardBus Socket Address + 832h: Card A ExCA Offset 32h  
Card B ExCA Offset 72h

Type: Read/Write

Default: 00h

Size: One byte

Description: These registers contain the low-byte of the 16-bit memory window end address for memory windows 0, 1, 2, 3, and 4. The 8 bits of these registers correspond to bits A19–A12 of the end address.



**ExCA memory window 0–4 end-address high-byte register (Index 13h/1Bh/23h/2Bh/33h)**

Bit	7	6	5	4	3	2	1	0
Name	ExCA memory window 0–4 end-address high-byte							
Type	R/W	R/W	R	R	R/W	R/W	R/W	R/W
Default	0	0	0	0	0	0	0	0

Register: **ExCA memory window 0 end-address high-byte**

Offset: CardBus Socket Address + 813h: Card A ExCA Offset 13h  
Card B ExCA Offset 53h

Register: **ExCA memory window 1 end-address high-byte**

Offset: CardBus Socket Address + 81Bh: Card A ExCA Offset 1Bh  
Card B ExCA Offset 5Bh

Register: **ExCA memory window 2 end-address high-byte**

Offset: CardBus Socket Address + 823h: Card A ExCA Offset 23h  
Card B ExCA Offset 63h

Register: **ExCA memory window 3 end-address high-byte**

Offset: CardBus Socket Address + 82Bh: Card A ExCA Offset 2Bh  
Card B ExCA Offset 6Bh

Register: **ExCA Memory window 4 end-address high-byte**

Offset: CardBus Socket Address + 833h: Card A ExCA Offset 33h  
Card B ExCA Offset 73h

Type: Read/Write

Default: 00h

Size: One byte

Description: These registers contain the high-nibble of the 16-bit memory window end address for memory windows 0, 1, 2, 3, and 4. The lower 4 bits of these registers correspond to bits A23–A20 of the end address. In addition, the memory window wait states are set in this register.

**Table 59. ExCA Memory Window 0–4 End-Address High-Byte Register Description**

BIT	TYPE	FUNCTION
7–6	R/W	MEMWS. Wait state. These bits specify the number of equivalent ISA wait states to be added to 16-bit memory accesses. The number of wait states added is equal to the binary value of these two bits.
5–4	R	Reserved. These bits return 0s when read. Writes have no effect.
3–0	R/W	ENDHN. End address high-nibble. These bits represent the upper address bits A23–A20 of the memory window and address.

# PCI4450 GFN/GJG PC Card and OHCI Controller

SCPS046 – JANUARY 1999

## ExCA memory window 0–4 offset-address low-byte register (Index 14h/1Ch/24h/2Ch/34h)

Bit	7	6	5	4	3	2	1	0
<b>Name</b>	ExCA memory window 0–4 offset-address low-byte							
<b>Type</b>	R/W	R/W	R/W	R/W	R/W	R/W	R/W	R/W
<b>Default</b>	0	0	0	0	0	0	0	0

Register: **ExCA memory window 0 offset-address low-byte**

Offset: CardBus Socket Address + 814h: Card A ExCA Offset 14h  
Card B ExCA Offset 54h

Register: **ExCA memory window 1 offset-address low-byte**

Offset: CardBus Socket Address + 81Ch: Card A ExCA Offset 1Ch  
Card B ExCA Offset 5Ch

Register: **ExCA memory window 2 offset-address low-byte**

Offset: CardBus Socket Address + 824h: Card A ExCA Offset 24h  
Card B ExCA Offset 64h

Register: **ExCA memory window 3 offset-address low-byte**

Offset: CardBus Socket Address + 82Ch: Card A ExCA Offset 2Ch  
Card B ExCA Offset 6Ch

Register: **ExCA memory window 4 offset-address low-byte**

Offset: CardBus Socket Address + 834h: Card A ExCA Offset 34h  
Card B ExCA Offset 74h

Type: Read/Write

Default: 00h

Size: One byte

Description: These registers contain the low-byte of the 16-bit memory window offset address for memory windows 0, 1, 2, 3, and 4. The 8 bits of these registers correspond to bits A19–A12 of the offset address.



**ExCA memory window 0–4 offset-address high-byte register (15h/1Dh/25h/2Dh/35h)**

<b>Bit</b>	<b>7</b>	<b>6</b>	<b>5</b>	<b>4</b>	<b>3</b>	<b>2</b>	<b>1</b>	<b>0</b>
<b>Name</b>	ExCA memory window 0–4 offset-address high-byte							
<b>Type</b>	R/W	R/W	R/W	R/W	R/W	R/W	R/W	R/W
<b>Default</b>	0	0	0	0	0	0	0	0

Register: **ExCA memory window 0 offset-address high-byte**

Offset: CardBus Socket Address + 815h: Card A ExCA Offset 15h  
Card B ExCA Offset 55h

Register: **ExCA memory window 1 offset-address high-byte**

Offset: CardBus Socket Address + 81Dh: Card A ExCA Offset 1Dh  
Card B ExCA Offset 5Dh

Register: **ExCA memory window 2 offset-address high-byte**

Offset: CardBus Socket Address + 825h: Card A ExCA Offset 25h  
Card B ExCA Offset 65h

Register: **ExCA memory window 3 offset-address high-byte**

Offset: CardBus Socket Address + 82Dh: Card A ExCA Offset 2Dh  
Card B ExCA Offset 6Dh

Register: **ExCA memory window 4 offset-address high-byte**

Offset: CardBus Socket Address + 835h: Card A ExCA Offset 35h  
Card B ExCA Offset 75h

Type: Read/Write

Default: 00h

Size: One byte

Description: These registers contain the high 6 bits of the 16-bit memory window offset address for memory windows 0, 1, 2, 3, and 4. The lower 6 bits of these registers correspond to bits A25–A20 of the offset address. In addition, the write protection and common/attribute memory configurations are set in this register.

**Table 60. ExCA Memory Window 0–4 Offset-Address High-Byte Register Description**

<b>BIT</b>	<b>TYPE</b>	<b>FUNCTION</b>
7	R/W	WINWP. Write protect. This bit specifies whether write operations to this memory window are enabled. This bit is encoded as: 0 = Write operations are allowed (default) 1 = Write operations are not allowed
6	R/W	REG. This bit specifies whether this memory window is mapped to card attribute or common memory. This bit is encoded as: 0 = Memory window is mapped to common memory (default) 1 = Memory window is mapped to attribute memory
5–0	R/W	OFFHB. Offset address high-byte. These bits represent the upper address bits A25–A20 of the memory window offset address.

# PCI4450 GFN/GJG PC Card and OHCI Controller

SCPS046 – JANUARY 1999

## ExCA I/O window 0 & 1 offset-address low-byte register (Index 36h, 38h)

Bit	7	6	5	4	3	2	1	0
<b>Name</b>	ExCA I/O window 0 & 1 offset-address low-byte							
<b>Type</b>	R/W	R/W	R/W	R/W	R/W	R/W	R/W	R/W
<b>Default</b>	0	0	0	0	0	0	0	0

Register: **ExCA I/O window 0 offset-address low-byte**

Offset: CardBus Socket Address + 836h: Card A ExCA Offset 36h  
Card B ExCA Offset 76h

Register: **ExCA memory window 1 offset-address low-byte**

Offset: CardBus Socket Address + 838h: Card A ExCA Offset 38h  
Card B ExCA Offset 78h

Type: Read/Write

Default: 00h

Size: One byte

Description: These registers contain the low-byte of the 16-bit I/O window offset address for I/O windows 0 and 1. The 8 bits of these registers correspond to the lower 8 bits of the offset address, and bit 0 is always 0.

## ExCA I/O window 0 & 1 offset-address high-byte register (Index 37h, 39h)

Bit	7	6	5	4	3	2	1	0
<b>Name</b>	ExCA I/O window 0 & 1 offset-address high-byte							
<b>Type</b>	R/W	R/W	R/W	R/W	R/W	R/W	R/W	R/W
<b>Default</b>	0	0	0	0	0	0	0	0

Register: **ExCA I/O window 0 offset-address high-byte**

Offset: CardBus Socket Address + 837h: Card A ExCA Offset 37h  
Card B ExCA Offset 77h

Register: **ExCA memory window 1 offset-address high-byte**

Offset: CardBus Socket Address + 839h: Card A ExCA Offset 39h  
Card B ExCA Offset 79h

Type: Read/Write

Default: 00h

Size: One byte

Description: These registers contain the high-byte of the 16-bit I/O window offset address for I/O windows 0 and 1. The 8 bits of these registers correspond to the upper 8 bits of the offset address.



**ExCA card detect and general control register (Index 16h)**

Bit	7	6	5	4	3	2	1	0
Name	ExCA card detect and general control							
Type	R	R	W	R/W	R	R	R/W	R
Default	X	X	0	0	0	0	0	0

Register: **ExCA card detect and general control**

Type: Read-only, Write-only, Read/Write

Offset: CardBus Socket Address + 816h: Card A ExCA Offset 16h  
Card B ExCA Offset 56h

Default: XX00 0000b

Description: This register controls how the ExCA registers for the socket respond to card removal. It also reports the status of the  $\overline{VS1}$  and  $\overline{VS2}$  signals at the PC Card interface. Table 61 describes each bit in the ExCA card detect and general control register.

**Table 61. ExCA Card Detect and General Control Register Description**

BIT	TYPE	FUNCTION
7	R	VS2STAT. VS2. This bit reports the current state of the VS2 signal at the PC Card interface, and, therefore, does not have a default value. 0 = VS2 is low 1 = VS2 is high
6	R	VS1STAT. VS1. This bit reports the current state of the VS1 signal at the PC Card interface, and, therefore, does not have a default value. 0 = VS1 is low 1 = VS1 is high
5	W	SWCSC. Software card detect interrupt. If the card detect enable bit in the ExCA card status change interrupt configuration register is set, then writing a 1 to this bit causes a card detect card status change interrupt for the associated card socket. If the card detect enable bit is cleared to 0 in the ExCA card status change interrupt configuration register, then writing a 1 to the software card detect interrupt bit has no effect. This bit is write-only. A read operation of this bit always returns 0. Writing a 1 to this bit also clears it. If bit 2 of the ExCA global control register is set and a 1 is written to clear bit 3 of the ExCA card status change interrupt register, then this bit also gets cleared.
4	R/W	CDRESUME. Card detect resume enable. If this bit is set to 1 and once a card detect change has been detected on the CD1 and CD2 inputs, then the $\overline{RI\_OUT}$ output will go from high to low. The $\overline{RI\_OUT}$ remains low until the card status change bit in the ExCA card status change register is cleared. If this bit is a 0, then the card detect resume functionality is disabled. 0 = Card detect resume disabled (default) 1 = Card detect resume enabled
3–2	R	Reserved. These bits return 0s when read. Writes have no effect.
1	R/W	REGCONFIG. Register configuration upon card removal. This bit controls how the ExCA registers for the socket react to a card removal event. This bit is encoded as: 0 = No change to ExCA registers upon card removal (default) 1 = Reset ExCA registers upon card removal
0	R	Reserved. This bit returns 0 when read. A write has no effect.

# PCI4450 GFN/GJG PC Card and OHCI Controller

SCPS046 – JANUARY 1999

## ExCA global control register (Index 1Eh)

Bit	7	6	5	4	3	2	1	0
Name	ExCA global control							
Type	R	R	R	R/W	R/W	R/W	R/W	R/W
Default	0	0	0	0	0	0	0	0

Register: **ExCA global control**  
 Type: Read-only, Read/Write  
 Offset: CardBus Socket Address + 81Eh: Card A ExCA Offset 1Eh  
 Card B ExCA Offset 5Eh

Default: 00h

Description: This register controls both PC Card sockets, and is not duplicated for each socket. The host interrupt mode bits in this register are retained for 82365SL compatibility.

**Table 62. ExCA Global Control Register Description**

BIT	TYPE	FUNCTION
7-5	R	Reserved. These bits return 0s when read. Writes have no effect.
4	R/W	INTMODEB. Level/edge interrupt mode select – card B. This bit selects the signaling mode for the PCI4450 host interrupt for Card B interrupts. This bit is encoded as: 0 = Host interrupt is edge mode (default) 1 = Host interrupt is level mode
3	R/W	INTMODEA. Level/edge interrupt mode select – card A. This bit selects the signaling mode for the PCI4450 host interrupt for card A interrupts. This bit is encoded as: 0 = Host interrupt is edge mode (default) 1 = Host interrupt is level mode
2	R/W	IFCMODE. Interrupt flag clear mode select. This bit selects the interrupt flag clear mechanism for the flags in the ExCA card status change register. This bit is encoded as: 0 = Interrupt flags cleared by read of CSC register (default) 1 = Interrupt flags cleared by explicit write back of 1
1	R/W	CSCMODE. Card status change level/edge mode select. This bit selects the signaling mode for the PCI4450 host interrupt for card status changes. This bit is encoded as: 0 = Host interrupt is edge mode (default) 1 = Host interrupt is level mode
0	R/W	PWRDWN. PWRDWN mode select. When the bit is set to 1, the PCI4450 is in power-down mode. In power-down mode the PCI4450 card outputs are placed in a high-impedance state until an active cycle is executed on the card interface. Following an active cycle the outputs are again placed in a high-impedance state. The PCI4450 still receives DMA requests, functional interrupts and/or card status change interrupts; however, an actual card access is required to “wake up” the interface. This bit is encoded as: 0 = Power-down mode disabled (default) 1 = Power-down mode enabled





**ExCA memory window 0–4 page register (Index 40h, 41h, 42h, 43h, 44h)**

Bit	7	6	5	4	3	2	1	0
Name	ExCA memory window 0–4 page							
Type	R/W	R/W	R/W	R/W	R/W	R/W	R/W	R/W
Default	0	0	0	0	0	0	0	0

Register: **ExCA memory window 0–4 page**

Type: Read/Write

Offset: CardBus Socket Address + 840h, 841h, 842h, 843h, 844h

Default: 00h

Description: The upper 8 bits of a 4-byte PCI memory address are compared to the contents of this register when decoding addresses for 16-bit memory windows. Each window has its own page register, all of which default to 00h. By programming this register to a nonzero value, host software may locate 16-bit memory windows in any one of 256 16M-byte regions in the 4 Gigabyte PCI address space. These registers are only accessible when the ExCA registers are memory mapped, that is, these registers may not be accessed using the index/data I/O scheme.

# PCI4450 GFN/GJG PC Card and OHCI Controller

SCPS046 – JANUARY 1999

## CardBus socket registers (functions 0 and 1)

The PCMCIA CardBus Specification requires a CardBus socket controller to provide five 32-bit registers which report and control the socket-specific functions. The PCI4450 provides the CardBus socket/ExCA base address register (PCI offset 10h) to locate these CardBus socket registers in PCI memory address space. Each socket has a separate base address register for accessing the CardBus socket registers, see Figure 21 below. Table 63 illustrates the location of the socket registers in relation to the CardBus socket/ExCA base address.

**Table 63. CardBus Socket Registers**

REGISTER NAME	OFFSET
Socket event †	00h
Socket mask †	04h
Socket present state †	08h
Socket force event	0Ch
Socket control †	10h
Reserved	14h
Reserved	18h
Reserved	1Ch
Socket power management	20h

† One or more bits in this register are cleared only by the assertion of  $\overline{G\_RST}$  when  $\overline{PME}$  is enabled. If  $\overline{PME}$  is not enabled, then this bit is cleared by the assertion of  $\overline{PRST}$  or  $\overline{G\_RST}$ .

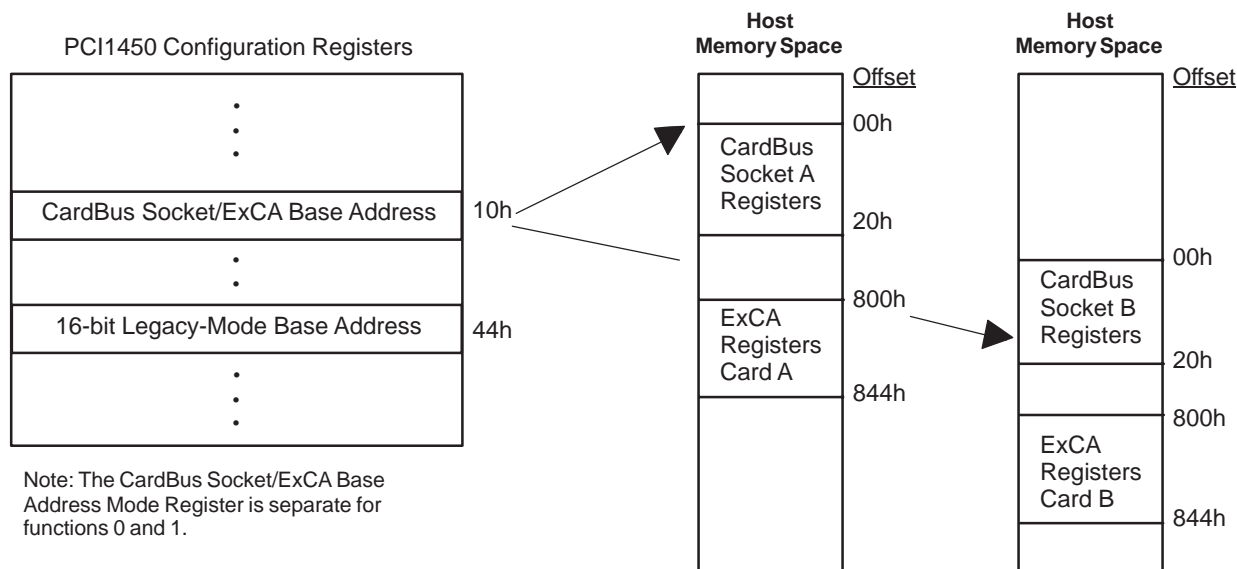

**Figure 21. Accessing CardBus Socket Registers Through PCI Memory**

socket event register

Bit	31	30	29	28	27	26	25	24	23	22	21	20	19	18	17	16
Name	Socket event															
Type	R	R	R	R	R	R	R	R	R	R	R	R	R	R	R	R
Default	0	0	0	0	0	0	0	0	0	0	0	0	0	0	0	0
Bit	15	14	13	12	11	10	9	8	7	6	5	4	3†	2†	1†	0†
Name	Socket event															
Type	R	R	R	R	R	R	R	R	R	R	R	R	R/WC	R/WC	R/WC	R/WC
Default	0	0	0	0	0	0	0	0	0	0	0	0	0	0	0	0

Register: **Socket event**

Type: Read-only, Read/Write to Clear

Offset: CardBus Socket Address + 00h

Default: 0000 0000h

Description: This register indicates a change in socket status has occurred. These bits do not indicate what the change is, only that one has occurred. Software must read the socket present state register for current status. Each bit in this register can be cleared by writing a 1 to that bit. The bits in this register can be set to a 1 by software through writing a 1 to the corresponding bit in the socket force event register. All bits in this register are cleared by PCI reset. They may be immediately set again, if, when coming out of PC Card reset, the bridge finds the status unchanged (i.e., CSTSCHG reasserted or card detect is still true). Software needs to clear this register before enabling interrupts. If it is not cleared and interrupts are enabled, then an interrupt is generated based on any bit set and not masked.

Table 64. Socket Event Register Description

BIT	TYPE	FUNCTION
31–4	R	Reserved. These bits return 0s when read.
3†	R/WC	PWREVENT. Power cycle. This bit is set when the PCI4450 detects that the PWRCYCLE bit in the socket present state register has changed. This bit is cleared by writing a 1.
2†	R/WC	CD2EVENT. CCD2. This bit is set when the PCI4450 detects that the CDETECT2 field in the socket present state register has changed. This bit is cleared by writing a 1.
1†	R/WC	CD1EVENT. CCD1. This bit is set when the PCI4450 detects that the CDETECT1 field in the socket present state register has changed. This bit is cleared by writing a 1.
0†	R/WC	CSTSEVENT. CSTSCHG. This bit is set when the CARDSTS field in the socket present state register has changed state. For CardBus cards, this bit is set on the rising edge of the CSTSCHG signal. For 16-bit PC Cards, this bit is set on both transitions of the CSTSCHG signal. This bit is reset by writing a 1.

† This bit is cleared only by the assertion of  $\overline{G\_RST}$  when  $\overline{PME}$  is enabled. If  $\overline{PME}$  is not enabled, then this bit is cleared by the assertion of  $\overline{PRST}$  or  $\overline{G\_RST}$ .

# PCI4450 GFN/GJG PC Card and OHCI Controller

SCPS046 – JANUARY 1999

## socket mask register

Bit	31	30	29	28	27	26	25	24	23	22	21	20	19	18	17	16
Name	Socket mask															
Type	R	R	R	R	R	R	R	R	R	R	R	R	R	R	R	R
Default	0	0	0	0	0	0	0	0	0	0	0	0	0	0	0	0
Bit	15	14	13	12	11	10	9	8	7	6	5	4	3†	2†	1†	0†
Name	Socket mask															
Type	R	R	R	R	R	R	R	R	R	R	R	R	R/W	R/W	R/W	R/W
Default	0	0	0	0	0	0	0	0	0	0	0	0	0	0	0	0

Register: **Socket mask**  
 Type: Read-only, Read/Write  
 Offset: CardBus Socket Address + 04h  
 Default: 0000 0000h  
 Description: This register allows software to control the CardBus card events which generate a status change interrupt. Table 65 below describes each bit in this register. The state of these mask bits does not prevent the corresponding bits from reacting in the socket event register.

**Table 65. Socket Mask Register Description**

BIT	TYPE	FUNCTION
31–4	R	Reserved. These bits return 0s when read.
3†	R/W	PWRMASK. Power cycle. This bit masks the PWRCYCLE bit in the socket present state register from causing a status change interrupt. 0 = PWRCYCLE event will not cause a CSC interrupt (default) 1 = PWRCYCLE event will cause a CSC interrupt
2–1†	R/W	CDMASK. Card detect mask. These bits mask the CDETECT1 and CDETECT2 bits in the socket present state register from causing a CSC interrupt. 00 = Insertion/removal will not cause CSC interrupt (default) 01 = Reserved (undefined) 10 = Reserved (undefined) 11 = Insertion/removal will cause CSC interrupt
0†	R/W	CSTSMASK. CSTSCHG mask. This bit masks the CARDSTS field in the socket present state register from causing a CSC interrupt. 0 = CARDSTS event will not cause CSC interrupt (default) 1 = CARDSTS event will cause CSC interrupt

† This bit is cleared only by the assertion of  $\overline{G\_RST}$  when  $\overline{PME}$  is enabled. If  $\overline{PME}$  is not enabled, then this bit is cleared by the assertion of  $\overline{PRST}$  or  $\overline{G\_RST}$ .



socket present state register

Bit	31	30	29	28	27	26	25	24	23	22	21	20	19	18	17	16
Name	Socket present state															
Type	R	R	R	R	R	R	R	R	R	R	R	R	R	R	R	R
Default	0	0	1	1	0	0	0	0	0	0	0	0	0	0	0	0
Bit	15	14	13	12	11	10	9	8	7	6	5	4	3	2	1	0
Name	Socket present state															
Type	R	R	R	R	R	R	R	R	R	R	R	R	R	R	R	R
Default	0	0	0	0	0	0	0	0	0	X	0	0	0	X	X	X

Register: **Socket present state**

Type: Read-only

Offset: CardBus Socket Address + 08h

Default: 3000 00XXh

Description: This register reports information about the socket interface. Writes to the socket force event register are reflected here as well as general socket interface status. Information about PC Card  $V_{CC}$  support and card type is only updated at each insertion. Also note that the PCI4450 uses the  $\overline{CCD1}$  and  $\overline{CCD2}$  signals during card identification, and changes on these signals during this operation are not reflected in this register.

Table 66. Socket Present State Register Description

BIT	TYPE	FUNCTION
31	R	YVSOCKET. YV socket. This bit indicates whether or not the socket can supply $V_{CC} = Y.YV$ to PC Cards. The PCI4450 does not support $Y.YV V_{CC}$ ; therefore, this bit is always reset unless overridden by the socket force event register. This bit is hardwired to 0.
30	R	XVSOCKET. XV socket. This bit indicates whether or not the socket can supply $V_{CC} = X.XV$ to PC Cards. The PCI4450 does not support $X.XV V_{CC}$ ; therefore, this bit is always reset unless overridden by the socket force event register. This bit is hardwired to 0.
29	R	3VSOCKET. 3-V socket. This bit indicates whether or not the socket can supply $V_{CC} = 3.3$ Vdc to PC Cards. The PCI4450 does support 3.3 V $V_{CC}$ ; therefore, this bit is always set unless overridden by the socket force event register.
28	R	5VSOCKET. 5-V socket. This bit indicates whether or not the socket can supply $V_{CC} = 5.0$ Vdc to PC Cards. The PCI4450 does support 5.0 V $V_{CC}$ ; therefore, this bit is always 1 unless overridden by the device control register (bit 6).
27–14	R	Reserved. These bits return 0s when read.
13	R	YVCARD. YV card. This bit indicates whether or not the PC Card inserted in the socket supports $V_{CC} = Y.Y$ Vdc. This bit can be set by writing to the corresponding bit in the socket force event register.
12	R	XVCARD. XV card. This bit indicates whether or not the PC Card inserted in the socket supports $V_{CC} = X.X$ Vdc. This bit can be set by writing to the corresponding bit in the socket force event register.
11	R	3VCARD. 3-V card. This bit indicates whether or not the PC Card inserted in the socket supports $V_{CC} = 3.3$ Vdc. This bit can be set by writing to the corresponding bit in the socket force event register.
10	R	5VCARD. 5-V card. This bit indicates whether or not the PC Card inserted in the socket supports $V_{CC} = 5.0$ Vdc.
9	R	BADVCCREQ. Bad $V_{CC}$ request. This bit indicates that the host software has requested that the socket be powered at an invalid voltage. 0 = Normal operation (default) 1 = Invalid $V_{CC}$ request by host software

# PCI4450 GFN/GJG PC Card and OHCI Controller

SCPS046 – JANUARY 1999

**Table 66. Socket Present State Register Description (continued)**

BIT	TYPE	FUNCTION
8	R	DATALOST. Data lost. This bit indicates that a PC Card removal event may have caused lost data because the cycle did not terminate properly or because write data still resides in the PCI4450. 0 = Normal operation (default) 1 = Potential data loss due to card removal
7	R	NOTACARD. Not a card. This bit indicates that an unrecognizable PC Card has been inserted in the socket. This bit is not updated until a valid PC Card is inserted into the socket. 0 = Normal operation (default) 1 = Unrecognizable PC Card detected
6	R	IREQCINT. $\overline{\text{READY}}(\overline{\text{IREQ}})/\overline{\text{CINT}}$ . This bit indicates the current status of the $\overline{\text{READY}}(\overline{\text{IREQ}})/\overline{\text{CINT}}$ signal at the PC Card interface. 0 = $\overline{\text{READY}}(\overline{\text{IREQ}})/\overline{\text{CINT}}$ is low 1 = $\overline{\text{READY}}(\overline{\text{IREQ}})/\overline{\text{CINT}}$ is high
5	R	CBCARD. CardBus card detected. This bit indicates that a CardBus PC Card is inserted in the socket. This bit is not updated until another card interrogation sequence occurs (card insertion).
4	R	16BITCARD. 16-bit card detected. This bit indicates that a 16-bit PC Card is inserted in the socket. This bit is not updated until another card interrogation sequence occurs (card insertion).
3	R	PWRCYCLE. Power cycle. This bit indicates that the status of each card powering request. This bit is encoded as: 0 = Socket is powered down (default) 1 = Socket is powered up
2	R	CDETECT2. $\overline{\text{CCD2}}$ . This bit reflects the current status of the $\overline{\text{CCD2}}$ signal at the PC Card interface. Changes to this signal during card interrogation are not reflected here. 0 = $\overline{\text{CCD2}}$ is low (PC Card may be present) 1 = $\overline{\text{CCD2}}$ is high (PC Card not present)
1	R	CDETECT1. $\overline{\text{CCD1}}$ . This bit reflects the current status of the $\overline{\text{CCD1}}$ signal at the PC Card interface. Changes to this signal during card interrogation are not reflected here. 0 = $\overline{\text{CCD1}}$ is low (PC Card may be present) 1 = $\overline{\text{CCD1}}$ is high (PC Card not present)
0	R	CARDSTS. CSTSCHG. This bit reflects the current status of the CSTSCHG signal at the PC Card interface. 0 = CSTSCHG is low 1 = CSTSCHG is high



socket force event register

Bit	31	30	29	28	27	26	25	24	23	22	21	20	19	18	17	16
Name	Socket force event															
Type	R	R	R	R	R	R	R	R	R	R	R	R	R	R	R	R
Default	0	0	0	0	0	0	0	0	0	0	0	0	0	0	0	0
Bit	15	14	13	12	11	10	9	8	7	6	5	4	3	2	1	0
Name	Socket force event															
Type	R	W	W	W	W	W	W	W	W	R	W	W	W	W	W	W
Default	0	0	0	0	0	0	0	0	0	0	0	0	0	0	0	0

Register: **Socket force event**  
 Type: Read-only, Write-only  
 Offset: CardBus Socket Address + 0Ch  
 Default: 0000 XXXXh  
 Description: This register is used to force changes to the socket event register and the socket present state register. The CVSTEST bit in this register must be written when forcing changes that require card interrogation.

Table 67. Socket Force Event Register Description

BIT	TYPE	FUNCTION
31–15	R	Reserved. These bits return 0s when read.
14	W	CVSTEST. Card VS test. When this bit is set, the PCI4450 reinterrogates the PC Card, updates the socket present state register, and re-enables the socket power control.
13	W	FYVCARD. Force YV card. Writes to this bit cause the YVCARD bit in the socket present state register to be written. When set, this bit disables the socket power control.
12	W	FXVCARD. Force XV card. Writes to this bit cause the XVCARD bit in the socket present state register to be written. When set, this bit disables the socket power control.
11	W	F3VCARD. Force 3-V card. Writes to this bit cause the 3VCARD bit in the socket present state register to be written. When set, this bit disables the socket power control.
10	W	F5VCARD. Force 5-V card. Writes to this bit cause the 5VCARD bit in the socket present state register to be written. When set, this bit disables the socket power control.
9	W	FBADVCCREQ. Force BadVccReq. Changes to the BADVCCREQ bit in the socket present state register can be made by writing this bit.
8	W	FDATALOST. Force data lost. Writes to this bit cause the DATALOST bit in the socket present state register to be written.
7	W	FNOTACARD. Force not a card. Writes to this bit cause the NOTACARD bit in the socket present state register to be written.
6	R	Reserved. This bit returns 0 when read.
5	W	FCBCARD. Force CardBus card. Writes to this bit cause the CBCARD bit in the socket present state register to be written.
4	W	F16BITCARD. Force 16-bit card. Writes to this bit cause the 16BITCARD bit in the socket present state register to be written.
3	W	FPWRCYCLE. Force power cycle. Writes to this bit cause the PWREVENT bit in the socket event register to be written, and the PWRCYCLE bit in the socket present state register is unaffected.
2	W	FCDETECT2. Force $\overline{\text{CCD2}}$ . Writes to this bit cause the CD2EVENT bit in the socket event register to be written, and the CDETECT2 bit in the socket present state register is unaffected.
1	W	FCDETECT1. Force $\overline{\text{CCD1}}$ . Writes to this bit cause the CD1EVENT bit in the socket event register to be written, and the CDETECT1 bit in the socket present state register is unaffected.
0	W	FCARDSTS. Force CSTSCHG. Writes to this bit cause the CSTSEVENT bit in the socket event register to be written. The CARDSTS bit in the socket present state register is unaffected.

# PCI4450 GFN/GJG PC Card and OHCI Controller

SCPS046 – JANUARY 1999

## socket control register

Bit	31	30	29	28	27	26	25	24	23	22	21	20	19	18	17	16
Name	Socket control															
Type	R	R	R	R	R	R	R	R	R	R	R	R	R	R	R	R
Default	0	0	0	0	0	0	0	0	0	0	0	0	0	0	0	0
Bit	15	14	13	12	11	10	9	8	7	6†	5†	4†	3	2†	1†	0†
Name	Socket control															
Type	R	R	R	R	R	R	R	R	R/W	R/W	R/W	R/W	R	R/W	R/W	R/W
Default	0	0	0	0	0	0	0	0	0	0	0	0	0	0	0	0

Register: **Socket control**  
 Type: Read-only, Read/Write  
 Offset: CardBus Socket Address + 10h  
 Default: 0000 0000h  
 Description: This register provides control of the voltages applied to the socket's  $V_{PP}$  and  $V_{CC}$ . The PCI4450 ensures that the socket is powered up only at acceptable voltages when a CardBus card is inserted.

**Table 68. Socket Control Register Description**

BIT	TYPE	FUNCTION
31–8	R	Reserved. These bits return 0s when read.
7	R/W	<p>STOPCLK. This bit controls how the CardBus clock run state machine decides when to stop the CardBus clock to the CardBus Card:</p> <p>0 = The PCI4450 Clock run master will try to stop the clock to the CardBus Card under the following two conditions:          The CardBus interface is idle for 8 clocks and          There is a request from the PCI master to stop the PCI clock.</p> <p>1 = The PCI4450 clock run master will try to stop the clock to the CardBus card under the following condition:          The CardBus interface is idle for 8 clocks.</p> <p>In summary, if this bit is set to 1, then the CardBus controller will try to stop the clock to the CardBus card independent of the PCI clock run signal. The only condition that has to be satisfied in this case is the CardBus interface sampled idle for 8 clocks.</p>
6–4†	R/W	<p>VCCCTRL. <math>V_{CC}</math> control. These bits are used to request card <math>V_{CC}</math> changes.</p> <p>000 = Request power off (default)          001 = Reserved          010 = Request <math>V_{CC}</math> = 5.0 V          011 = Request <math>V_{CC}</math> = 3.3 V          100 = Request <math>V_{CC}</math> = X.XV          101 = Request <math>V_{CC}</math> = Y.YV          110 = Reserved          111 = Reserved</p>
3	R	Reserved. This bit returns 0 when read.
2–0†	R/W	<p>VPPCTRL. <math>V_{PP}</math> control. These bits are used to request card <math>V_{PP}</math> changes.</p> <p>000 = Request power off (default)          001 = Request <math>V_{PP}</math> = 12.0 V          010 = Request <math>V_{PP}</math> = 5.0 V          011 = Request <math>V_{PP}</math> = 3.3 V          100 = Request <math>V_{PP}</math> = X.XV          101 = Request <math>V_{PP}</math> = Y.YV          110 = Reserved          111 = Reserved</p>

† This bit is cleared only by the assertion of  $\overline{G\_RST}$  when  $\overline{PME}$  is enabled. If  $\overline{PME}$  is not enabled, then this bit is cleared by the assertion of  $\overline{PRST}$  or  $\overline{G\_RST}$ .





**socket power management register**

<b>Bit</b>	31	30	29	28	27	26	25	24	23	22	21	20	19	18	17	16
<b>Name</b>	Socket power management															
<b>Type</b>	R	R	R	R	R	R	R	R	R	R	R	R	R	R	R	R/W
<b>Default</b>	0	0	0	0	0	0	0	0	0	0	0	0	0	0	0	0
<b>Bit</b>	15	14	13	12	11	10	9	8	7	6	5	4	3	2	1	0
<b>Name</b>	Socket power management															
<b>Type</b>	R	R	R	R	R	R	R	R	R	R	R	R	R	R	R	R/W
<b>Default</b>	0	0	0	0	0	0	0	0	0	0	0	0	0	0	0	0

Register: **Socket power management**  
 Type: Read-only, Read/Write  
 Offset: CardBus Socket Address + 20h  
 Default: 0000 0000h  
 Description: This register provides power management control over the socket through a mechanism for slowing or stopping the clock on the card interface when the card is idle.

**Table 69. Socket Power Management Register Description**

BIT	TYPE	FUNCTION
31–26	R	Reserved. These bits return 0s when read.
25	R	SKTACCES. Socket access status. This bit provides information on when a socket access has occurred. This bit is cleared by a read access. 0 = No PC Card access has occurred (default) 1 = PC Card has been accessed
24	R	SKTMODE. Socket mode status. This bit provides clock mode information. 0 = Normal clock operation 1 = Clock frequency has changed
23–17	R	Reserved. These bits return 0s when read.
16	R/W	CLKCTRLLEN. CardBus clock control enable. This bit, when set, enables clock control according to bit 0 (CLKCTRL). 0 = Clock control disabled (default) 1 = Clock control enabled
15–1	R	Reserved. These bits return 0s when read.
0	R/W	This bit determines whether the CardBus clock run master stops the CCLK or slows the clock when it detects idle activity on the CardBus interface. 0 = Stop the CardBus clock using the clock run protocol when there is no activity on the CardBus interface (default). 1 = Divide PCI clock by 16 using the clock run protocol when there is no activity on the CardBus interface.

# PCI4450 GFN/GJG PC Card and OHCI Controller

SCPS046 – JANUARY 1999

## distributed DMA (DDMA) registers

The DMA base address, programmable in PCI configuration space at offset 98h, points to a 16-byte region in PCI I/O space where the DDMA registers reside. Table 70 summarizes the names and locations of these registers. These registers are identical in function, but different in location from the Intel 8237 DMA controller. The similarity between the register models retains some level of compatibility with legacy DMA and simplifies the translation required by the master DMA device when forwarding legacy DMA writes to DMA channels.

These PCI4450 DMA register definitions are identical to those registers of the same name in the 8237 DMA controller; however, some register bits defined in the 8237 do not apply to distributed DMA in a PCI environment. In such cases, the PCI4450 will implement these obsolete register bits as nonfunctional, read-only bits. The reserved registers shown in Table 70 are implemented as read-only, and return 0s when read. Writes to reserved registers have no effect.

**Table 70. Distributed DMA Registers**

TYPE	REGISTER NAME			DMA BASE ADDRESS OFFSET
R	Reserved	Page	Current address	00h
W			Base address	
R	Reserved	Reserved	Current count	04h
W			Base count	
R	N/A	Reserved	N/A	08h
W	Mode		Request	
R	Multichannel	Reserved	N/A	0Ch
W	Mask		Master clear	



**DMA current address / base address register**

Bit	15	14	13	12	11	10	9	8
Name	DMA current address/base address							
Type	R/W	R/W	R/W	R/W	R/W	R/W	R/W	R/W
Default	0	0	0	0	0	0	0	0
Bit	7	6	5	4	3	2	1	0
Name	DMA current address/base address							
Type	R/W	R/W	R/W	R/W	R/W	R/W	R/W	R/W
Default	0	0	0	0	0	0	0	0

Register: **DMA current address/base address**

Type: Read/Write

Offset: DMA Base Address + 00h

Default: 00 0000h

Size: Two bytes

Description: This register is used to set the starting (base) memory address of a DMA transfer. Reads from this register indicate the current memory address of a direct memory transfer.

For the 8-bit DMA transfer mode, the DMA current address register contents are presented on AD15–0 of the PCI bus during the address phase. Bits 7–0 of the DMA page register are presented on AD23–AD16 of the PCI bus during the address phase.

For the 16-bit DMA transfer mode, the DMA current address register contents are presented on AD16–AD1 of the PCI bus during the address phase, and AD0 is driven to logic '0'. Bits 7–1 of the DMA page register are presented on AD23–AD17 of the PCI bus during the address phase, and bit 0 is ignored.

**DMA page register**

Bit	7	6	5	4	3	2	1	0
Name	DMA page							
Type	R/W	R/W	R/W	R/W	R/W	R/W	R/W	R/W
Default	0	0	0	0	0	0	0	0

Register: **DMA page**

Type: Read/Write

Offset: DMA Base Address + 02h

Default: 0000h

Size: One byte

Description: This register is used to set the upper byte of the address of a DMA transfer. Details of the address represented by this register are explained in the DMA current address/base address register, above.

# PCI4450 GFN/GJG PC Card and OHCI Controller

SCPS046 – JANUARY 1999

## DMA current count / base count register

<b>Bit</b>	<b>15</b>	<b>14</b>	<b>13</b>	<b>12</b>	<b>11</b>	<b>10</b>	<b>9</b>	<b>8</b>
<b>Name</b>	DMA current count/base count							
<b>Type</b>	R/W	R/W	R/W	R/W	R/W	R/W	R/W	R/W
<b>Default</b>	0	0	0	0	0	0	0	0
<b>Bit</b>	<b>7</b>	<b>6</b>	<b>5</b>	<b>4</b>	<b>3</b>	<b>2</b>	<b>1</b>	<b>0</b>
<b>Name</b>	DMA current count/base count							
<b>Type</b>	R/W	R/W	R/W	R/W	R/W	R/W	R/W	R/W
<b>Default</b>	0	0	0	0	0	0	0	0

Register: **DMA current count/base count**

Type: Read/Write

Offset: DMA Base Address + 04h

Default: 0000h

Size: Two bytes

Description: This register is used to set the total transfer count, in bytes, of a direct memory transfer. Reads from this register indicate the current count of a direct memory transfer. In the 8-bit transfer mode, the count is decremented by 1 after each transfer. Likewise, the count is decremented by 2 in 16-bit transfer mode.

## DMA command register

<b>Bit</b>	<b>7</b>	<b>6</b>	<b>5</b>	<b>4</b>	<b>3</b>	<b>2</b>	<b>1</b>	<b>0</b>
<b>Name</b>	DMA command							
<b>Type</b>	R	R	R	R	R	R/W	R	R
<b>Default</b>	0	0	0	0	0	0	0	0

Register: **DMA command**

Type: Read-only, Read/Write

Offset: DMA Base Address + 08h

Default: 0000h

Size: One byte

Description: This register is used to enable and disable the controller; all other bits are reserved.

**Table 71. DDMA Command Register Description**

<b>BIT</b>	<b>TYPE</b>	<b>FUNCTION</b>
7–3	R	Reserved. These bits return 0s when read.
2	R/W	DMA controller enable. This bit enables and disables the distributed DMA slave controller in the PCI4450, and defaults to the enabled state. 0 = DMA controller enabled (default) 1 = DMA controller disabled
1–0	R	Reserved. These bits return 0s when read.



**DMA status register**

Bit	7	6	5	4	3	2	1	0
Name	DMA status							
Type	R	R	R	R	R	R	R	R
Default	0	0	0	0	0	0	0	0

Register: **DMA status**  
 Type: Read-only  
 Offset: DMA Base Address + 08h  
 Default: 0000h  
 Size: One byte  
 Description: This register indicates the terminal count and DMA request ( $\overline{\text{DREQ}}$ ) status.

**Table 72. DMA Status Register Description**

BIT	TYPE	FUNCTION
7–4	R	DREQSTAT. Channel request. In the 8237, these bits indicate the status of the $\overline{\text{DREQ}}$ signal of each DMA channel. In the PCI4450, these bits indicate the $\overline{\text{DREQ}}$ status of the single socket being serviced by this register. All four bits are set when the PC Card asserts its $\overline{\text{DREQ}}$ signal, and are reset when $\overline{\text{DREQ}}$ is deasserted. The status of the mask bit in the DMA multichannel mask register has no effect on these bits.
3–0	R	TC. Channel terminal count. The 8327 uses these bits to indicate the TC status of each of its four DMA channels. In the PCI4450, these bits report information about just a single DMA channel; therefore, all four of these register bits indicate the TC status of the single socket being serviced by this register. All four bits are set when the terminal count (TC) is reached by the DMA channel. These bits are reset when read or when the DMA channel is reset

**DMA request register**

Bit	7	6	5	4	3	2	1	0
Name	DMA request							
Type	W	W	W	W	W	W	W	W
Default	0	0	0	0	0	0	0	0

Register: **DMA request**  
 Type: Write-only  
 Offset: DMA Base Address + 09h  
 Default: 0000h  
 Size: One byte  
 Description: This register is used to request a DDMA transfer through software. Any write to this register enables software requests. This register is to be used in block mode only.

# PCI4450 GFN/GJG PC Card and OHCI Controller

SCPS046 – JANUARY 1999

## DMA mode register

Bit	7	6	5	4	3	2	1	0
Name	DMA mode							
Type	R/W	R/W	R/W	R/W	R/W	R/W	R/W	R
Default	0	0	0	0	0	0	0	0

Register: **DMA mode**  
 Type: Read-only, Read/Write  
 Offset: DMA Base Address + 0Bh  
 Default: 0000h  
 Size: One byte  
 Description: This register is used to set the DMA transfer mode.

**Table 73. DDMA Mode Register Description**

BIT	TYPE	FUNCTION
7–6	R/W	DMAMODE. Mode select bits. The PCI4450 uses these bits to determine the transfer mode. 00 = Demand mode select (default) 01 = Single mode select 10 = Block mode select 11 = Reserved
5	R/W	INCDEC. Address increment/decrement. The PCI4450 uses this register bit to select the memory address in the DMA current address/base address register to increment or decrement after each data transfer. This is in accordance with the 8237 use of this register bit, and is encoded as follows: 0 = Addresses increment (default) 1 = Addresses decrement
4	R/W	AUTOINIT. Auto-initialization bit. 0 = Auto-initialization disabled (default) 1 = Auto-initialization enabled
3–2	R/W	XFERTYPE. Transfer type. These bits select the type of direct memory transfer to be performed. A memory write transfer moves data from the PCI4450 PC Card interface to memory, and a memory read transfer moves data from memory to the PCI4450 PC Card interface. The field is encoded as: 00 = No transfer selected (default) 01 = Write transfer 10 = Read transfer 11 = Reserved
1–0	R	Reserved. These bits return 0s when read.



**DMA master clear register**

Bit	7	6	5	4	3	2	1	0
Name	DMA master clear							
Type	W	W	W	W	W	W	W	W
Default	0	0	0	0	0	0	0	0

Register: **DMA master clear**  
 Type: Write-only  
 Offset: DMA Base Address + 0Dh  
 Default: 0000h  
 Size: One byte  
 Description: This register is used to reset the DDMA controller, and resets all DDMA registers.

**DMA multichannel mask register**

Bit	7	6	5	4	3	2	1	0
Name	DMA multichannel mask							
Type	R	R	R	R	R	R	R	R/W
Default	0	0	0	0	0	0	0	1

Register: **DMA multichannel mask**  
 Type: Read-only, Read/Write  
 Offset: DMA Base Address + 0Fh  
 Default: 0000h  
 Size: One byte  
 Description: The PCI4450 uses only the least significant bit of this register to mask the PC Card DMA channel. The PCI4450 sets the mask bit when the PC Card is removed. Host software is responsible for either resetting the socket's DMA controller or re-enabling the mask bit.

**Table 74. DDMA MultiChannel Mask Register Description**

BIT	TYPE	FUNCTION
7-1	R	Reserved. These bits return 0s when read.
0	R/W	MASKBIT. Mask select bit. This bit masks incoming <u>DREQ</u> signals from the PC Card. When set, the socket ignores DMA requests from the card. When cleared (or when reset), incoming <u>DREQ</u> assertions are serviced normally. 0 = DDMA <u>service</u> provided on card <u>DREQ</u> 1 = Socket <u>DREQ</u> signal ignored (default)

**OHCI-Lynx controller programming model**

This section describes the internal registers used to program the link function, including both PCI configuration registers and Open HCI registers. All registers are detailed in the same format. A brief description is provided for each register, followed by the register offset and a bit-table describing the reset state for each register.

A bit description table is typically included that indicates bit field names, a detailed field description, and field access tags. Table 75 describes the field access tags.

**Table 75. Bit Field Access Tag Descriptions**

ACCESS TAG	NAME	MEANING
R	Read	Field may be read by software.
W	Write	Field may be written by software to any value.
S	Set	Field may be set by a write of 1. Writes of 0 have no effect.
C	Clear	Field may be cleared by a write of 1. Writes of 0 have no effect.
U	Update	Field may be autonomously updated by the PCI4450.

**PCI configuration registers**

The PCI4450 link function configuration header is compliant with the PCI Specification as a standard header. Table 76 illustrates the PCI configuration header which includes both the predefined portion of the configuration space and the user definable registers. The registers that are labeled Reserved are read-only returning 0 when read and are not applicable to the link function or have been reserved by the PCI specification for future use.

**Table 76. PCI Configuration Register Map**

REGISTER NAME				OFFSET
Device ID		Vendor ID		00h
Status		Command		04h
Class code			Revision ID	08h
BIST	Header type	Latency timer	Cache line size	0Ch
Open HCI registers base address				10h
TI extension registers base address				14h
Reserved				18h
Reserved				1Ch
Reserved				20h
Reserved				24h
Reserved				28h
Subsystem ID		Subsystem vendor ID		2Ch
Reserved				30h
Reserved			Capabilitespointer	34h
Reserved				38h
Max latency	Min grant	Interrupt pin	Interrupt line	3Ch
PCI OHCI control				40h
Power management capabilities		Next item pointer	Capability ID	44h
PM data	PMCSR_BSE	Power management CSR		48h
Reserved				4C–ECh
PCI miscellaneous configuration				F0h
Link_enhancements				F4h
Subsystem ID alias		Subsystem vendor ID alias		F8h
GPIO3	GPIO2	GPIO1	GPIO0	FCh





**vendor ID register**

Bit	15	14	13	12	11	10	9	8	7	6	5	4	3	2	1	0
<b>Name</b>	Vendor ID															
<b>Type</b>	R	R	R	R	R	R	R	R	R	R	R	R	R	R	R	R
<b>Default</b>	0	0	0	1	0	0	0	0	0	1	0	0	1	1	0	0

Register: **Vender ID**

Type: Read-only

Offset: 00h

Default: 104Ch

Description: This 16-bit read-only register contains a value allocated by the PCI SIG and identifies the manufacturer of the PCI device. The vendor ID assigned to Texas Instruments is 104Ch.

**device ID register**

Bit	15	14	13	12	11	10	9	8	7	6	5	4	3	2	1	0
<b>Name</b>	Device ID															
<b>Type</b>	R	R	R	R	R	R	R	R	R	R	R	R	R	R	R	R
<b>Default</b>	1	0	0	0	0	0	0	0	0	0	0	1	0	0	0	1

Register: **Device ID register**

Type: Read-only

Offset: 02h

Default: 8011h

Description: This 16-bit read-only register contains a value assigned to the PCI4450 by Texas Instruments. The device identification for the PCI4450 OHCI controller function is 8011h.

# PCI4450 GFN/GJG PC Card and OHCI Controller

SCPS046 – JANUARY 1999

## PCI command register

Bit	15	14	13	12	11	10	9	8	7	6	5	4	3	2	1	0
Name	PCI command															
Type	R	R	R	R	R	R	R	R/W	R	R/W	R	R/W	R	R/W	R/W	R
Default	0	0	0	0	0	0	0	0	0	0	0	0	0	0	0	0

Register: **PCI command**  
 Type: Read-only, Read/Write  
 Offset: 04h  
 Default: 0000h  
 Description: The command register provides control over the PCI4450 link interface to the PCI bus. All bit functions adhere to the definitions in the PCI Local Bus Specification, as seen in the following bit descriptions.

**Table 77. PCI Command Register Description**

BIT	FIELD NAME	TYPE	DESCRIPTION
15–10	RSVD	R	Reserved. These bits return 0s when read.
9	FBB_ENB	R	Fast back-to-back enable. The PCI4450 will not generate fast back to back transactions, thus this bit returns 0 when read.
8	SERR_ENB	R/W	$\overline{\text{SERR}}$ enable. When set, the PCI4450 $\overline{\text{SERR}}$ driver is enabled. $\overline{\text{SERR}}$ can be asserted after detecting an address parity error on the PCI bus.
7	STEP_ENB	R	Address/data stepping control. The PCI4450 does not support address/data stepping, and this bit is hardwired to 0.
6	PERR_ENB	R/W	Parity error enable. When set, the PCI4450 is enabled to drive $\overline{\text{PERR}}$ response to parity errors through the $\overline{\text{PERR}}$ signal.
5	VGA_ENB	R	VGA palette snoop enable. The PCI4450 does not feature VGA palette snooping. This bit returns 0 when read.
4	MWI_ENB	R/W	Memory write and invalidate enable. When set, the PCI4450 is enabled to generate MWI PCI bus commands. If reset, the PCI4450 will generate memory write commands instead.
3	SPECIAL	R	Special cycle enable. The PCI4450 function does not respond to special cycle transactions. This bit returns 0 when read.
2	MASTER_ENB	R/W	Bus master enable. When set, the PCI4450 is enabled to initiate cycles on the PCI bus.
1	MEMORY_ENB	R/W	Memory response enable. Setting this bit enables the PCI4450 to respond to memory cycles on the PCI bus. This bit must be set to access OHCI registers.
0	IO_ENB	R	I/O space enable. The PCI4450 link does not implement any I/O mapped functionality; thus, this bit returns 0 when read.



**PCI status register**

Bit	15	14	13	12	11	10	9	8	7	6	5	4	3	2	1	0
Name	PCI status															
Type	RCU	RCU	RCU	RCU	RCU	R	R	RCU	R	R	R	R	R	R	R	R
Default	0	0	0	0	0	0	1	0	0	0	0	1	0	0	0	0

Register: **PCI status**  
 Type: Read-only, Read/Clear/Update  
 Offset: 06h  
 Default: 0210h  
 Description: PCI Bus Specification, as seen in the bit descriptions.

**Table 78. PCI Status Register Description**

BIT	FIELD NAME	TYPE	DESCRIPTION
15	PAR_ERR	RCU	Detected parity error. This bit is set when a parity error is detected, either address or data parity errors.
14	SYS_ERR	RCU	Signaled system error. This bit is set when $\overline{SERR}$ is enabled and the PCI4450 signaled a system error to the host.
13	MABORT	RCU	Received master abort. This bit is set when a cycle initiated by the PCI4450 on the PCI bus has been terminated by a master abort.
12	TABORT_REC	RCU	Received target abort. This bit is set when a cycle initiated by the PCI4450 on the PCI bus was terminated by a target abort.
11	TABORT_SIG	RCU	Signaled target abort. This bit is set by the PCI4450 when it terminates a transaction on the PCI bus with a target abort.
10–9	PCI_SPEED	R	DEVSEL timing. These bits encode the timing of $\overline{DEVSEL}$ and are hardwired 01b indicating that the PCI4450 asserts this signal at a medium speed on non-configuration cycle accesses.
8	DATAPAR	RCU	Data parity error detected. This bit is set when the following conditions have been met: a. $\overline{PERR}$ was asserted by any PCI device including the PCI4450 b. The PCI4450 was the bus master during the data parity error c. The parity error response bit is set in the command register
7	FBB_CAP	R	Fast back-to-back capable. The PCI4450 cannot accept fast back-to-back transactions; thus, this bit is hardwired to 0.
6	UDF	R	UDF supported. The PCI4450 does not support the user definable features; thus, this bit is hardwired to 0.
5	66MHZ	R	66 MHz capable. The PCI4450 operates at a maximum PCLK frequency of 33 MHz; therefore, this bit is hardwired to 0.
4	CAPLIST	R	Capabilities list. This bit returns 1 when read, and indicates that capabilities additional to standard PCI are implemented. The linked list of PCI power management capabilities is implemented in this function.
3–0	RSVD	R	Reserved. These bits return 0s when read.

# PCI4450 GFN/GJG PC Card and OHCI Controller

SCPS046 – JANUARY 1999

## class code and revision ID register

<b>Bit</b>	<b>31</b>	<b>30</b>	<b>29</b>	<b>28</b>	<b>27</b>	<b>26</b>	<b>25</b>	<b>24</b>	<b>23</b>	<b>22</b>	<b>21</b>	<b>20</b>	<b>19</b>	<b>18</b>	<b>17</b>	<b>16</b>
<b>Name</b>	Class code and revision ID															
<b>Type</b>	R	R	R	R	R	R	R	R	R	R	R	R	R	R	R	R
<b>Default</b>	0	0	0	0	1	1	0	0	0	0	0	0	0	0	0	0
<b>Bit</b>	<b>15</b>	<b>14</b>	<b>13</b>	<b>12</b>	<b>11</b>	<b>10</b>	<b>9</b>	<b>8</b>	<b>7</b>	<b>6</b>	<b>5</b>	<b>4</b>	<b>3</b>	<b>2</b>	<b>1</b>	<b>0</b>
<b>Name</b>	Class code and revision ID															
<b>Type</b>	R	R	R	R	R	R	R	R	R	R	R	R	R	R	R	R
<b>Default</b>	0	0	0	1	0	0	0	0	0	0	0	0	0	0	0	X

Register: **Class code and revision ID**

Type: Read-only

Offset: 08h

Default: 0C00 100Xh

Description: This read-only register categorizes the PCI4450 as a serial bus controller (0Ch), controlling an IEEE1394 bus (00h), with an OHCI programming model (10h). Furthermore, the TI chip revision is indicated in the lower byte.

**Table 79. Class Code and Revision ID Register Description**

<b>BIT</b>	<b>FIELD NAME</b>	<b>TYPE</b>	<b>DESCRIPTION</b>
31–24	BASECLASS	R	Base class. This field returns 0Ch when read, which broadly classifies the function as a serial bus controller.
23–16	SUBCLASS	R	Sub class. This field returns 00h when read, which specifically classifies the function as controlling a IEEE1394 serial bus.
15–8	PGMIF	R	Programming interface. This field returns 10h when read, which indicates that the programming model is compliant with the 1394 OHCI specification.
7–0	CHIPREV	R	Silicon revision. This field returns the silicon revision of the PCI4450.

**latency timer and class cache line size register**

Bit	15	14	13	12	11	10	9	8	7	6	5	4	3	2	1	0
<b>Name</b>	Latency timer and class cache line size															
<b>Type</b>	R/W	R/W	R/W	R/W	R/W	R/W	R/W	R/W	R/W	R/W	R/W	R/W	R/W	R/W	R/W	R/W
<b>Default</b>	0	0	0	0	0	0	0	0	0	0	0	0	0	0	0	0

Register: **Latency timer and class cache line size**

Type: Read/Write

Offset: 0Ch

Default: 0000h

Description: This register is programmed by host BIOS to indicate system cache line size and the latency timer associated with the PCI4450.

**Table 80. Latency Timer and Class Cache Line Size Register Description**

BIT	FIELD NAME	TYPE	DESCRIPTION
15–8	LATENCY_TIMER	R/W	PCI latency timer. The value in this register specifies the latency timer for the PCI4450, in units of PCI clock cycles. When the PCI4450 is a PCI bus initiator and asserts $\overline{\text{FRAME}}$ , the latency timer will begin counting from zero. If the latency timer expires before the PCI4450 transaction has terminated, then the PCI4450 will terminate the transaction when its $\overline{\text{GNT}}$ is deasserted.
7–0	CACHELINE_SZ	R/W	Cache line size. This value is used by the PCI4450 during memory write and invalidate, memory read line, and memory read multiple transactions.

**header type and BIST register**

Bit	15	14	13	12	11	10	9	8	7	6	5	4	3	2	1	0
<b>Name</b>	Header type and BIST															
<b>Type</b>	R	R	R	R	R	R	R	R	R	R	R	R	R	R	R	R
<b>Default</b>	0	0	0	0	0	0	0	0	0	0	0	0	0	0	0	0

Register: **Header type and BIST**

Type: Read-only

Offset: 0Eh

Default: 0000h

Description: This register indicates that this function is part of a multifunction device and has a standard PCI header type and indicates no built-in self-test.

**Table 81. Header Type and BIST Register Description**

BIT	FIELD NAME	TYPE	DESCRIPTION
15–8	BIST	R	Built-in self-test. The PCI4450 does not include a built-in self-test, and this field returns 00h when read.
7–0	HEADER_TYPE	R	PCI header type. The PCI4450 includes the standard PCI header, and this is communicated by returning 00h when this field is read.

# PCI4450 GFN/GJG PC Card and OHCI Controller

SCPS046 – JANUARY 1999

## open HCI registers base address register

<b>Bit</b>	<b>31</b>	<b>30</b>	<b>29</b>	<b>28</b>	<b>27</b>	<b>26</b>	<b>25</b>	<b>24</b>	<b>23</b>	<b>22</b>	<b>21</b>	<b>20</b>	<b>19</b>	<b>18</b>	<b>17</b>	<b>16</b>
<b>Name</b>	Open HCI registers base address															
<b>Type</b>	R/W	R/W	R/W	R/W	R/W	R/W	R/W	R/W	R/W	R/W	R/W	R/W	R/W	R/W	R/W	R/W
<b>Default</b>	0	0	0	0	0	0	0	0	0	0	0	0	0	0	0	0
<b>Bit</b>	<b>15</b>	<b>14</b>	<b>13</b>	<b>12</b>	<b>11</b>	<b>10</b>	<b>9</b>	<b>8</b>	<b>7</b>	<b>6</b>	<b>5</b>	<b>4</b>	<b>3</b>	<b>2</b>	<b>1</b>	<b>0</b>
<b>Name</b>	Open HCI registers base address															
<b>Type</b>	R/W	R/W	R/W	R/W	R/W	R	R	R	R	R	R	R	R	R	R	R
<b>Default</b>	0	0	0	0	0	0	0	0	0	0	0	0	0	0	0	0

Register: **Open HCI registers base address**  
 Type: Read-only, Read/Write  
 Offset: 10h  
 Default: 0000 0000h  
 Description: This register is programmed with a base address referencing the memory mapped OHCI control. When BIOS writes all 1s to this register, the value read back is FFFF F800h, indicating that at least 2 Kbytes of memory address space are required for the OHCI registers.

**Table 82. Open HCI Registers Base Address Register Description**

<b>BIT</b>	<b>FIELD NAME</b>	<b>TYPE</b>	<b>DESCRIPTION</b>
31–11	OHCIREG_PTR	R/W	Open HCI register pointer. Specifies the upper 21 bits of the 32-bit OHCI register base address.
10–4	OHCI_SZ	R	Open HCI register size. This field returns 0s when read, and indicates that the OHCI registers require a 2-Kbyte region of memory.
3	OHCI_PF	R	OHCI register prefetch. This bit returns 0, indicating the OHCI registers are nonprefetchable.
2–1	OHCI_MEMTYPE	R	Open HCI memory type. This field returns 0s when read, and indicates that the base register is 32 bits wide and mapping can be done anywhere in the 32-bit memory space.
0	OHCI_MEM	R	OHCI memory indicator. This bit returns 0, indicating the OHCI registers are mapped into system memory space.



**TI extension base address register**

<b>Bit</b>	31	30	29	28	27	26	25	24	23	22	21	20	19	18	17	16
<b>Name</b>	TI extension base address															
<b>Type</b>	R	R	R	R	R	R	R	R	R	R	R	R	R	R	R	R
<b>Default</b>	0	0	0	0	0	0	0	0	0	0	0	0	0	0	0	0
<b>Bit</b>	15	14	13	12	11	10	9	8	7	6	5	4	3	2	1	0
<b>Name</b>	TI extension base address															
<b>Type</b>	R	R	R	R	R	R	R	R	R	R	R	R	R	R	R	R
<b>Default</b>	0	0	0	0	0	0	0	0	0	0	0	0	0	0	0	0

Register: **TI extension base address**

Type: Read-only

Offset: 14h

Default: 0000 0000h

Description: This register is programmed with a base address referencing the memory mapped TI extension registers.

**Table 83. TI Extension Base Address Register Description**

BIT	FIELD NAME	TYPE	DESCRIPTION
31–11	TI_EXTREG_PTR	R/W	TI extension register pointer. Specifies the upper 20 bits of the 32-bit TI extension register base address.
10–4	TI_SZ	R	TI extension register size. This field returns 0s when read, and indicates that the TI extension registers require a 2-Kbyte region of memory.
3	TI_PF	R	TI extension register prefetch. This bit returns 0, indicating the TI extension registers are nonprefetchable.
2–1	TI_MEMTYPE	R	TI memory type. This field returns 0s when read, and indicates that the base register is 32 bits wide and mapping can be done anywhere in the 32-bit memory space.
0	TI_MEM	R	TI memory indicator. This bit returns 0, indicating the TI extension registers are mapped into system memory space.

# PCI4450 GFN/GJG PC Card and OHCI Controller

SCPS046 – JANUARY 1999

## PCI subsystem identification register

<b>Bit</b>	<b>31</b>	<b>30</b>	<b>29</b>	<b>28</b>	<b>27</b>	<b>26</b>	<b>25</b>	<b>24</b>	<b>23</b>	<b>22</b>	<b>21</b>	<b>20</b>	<b>19</b>	<b>18</b>	<b>17</b>	<b>16</b>
<b>Name</b>	PCI subsystem identification															
<b>Type</b>	RU	RU	RU	RU	RU	RU	RU	RU	RU	RU	RU	RU	RU	RU	RU	RU
<b>Default</b>	0	0	0	0	0	0	0	0	0	0	0	0	0	0	0	0
<b>Bit</b>	<b>15</b>	<b>14</b>	<b>13</b>	<b>12</b>	<b>11</b>	<b>10</b>	<b>9</b>	<b>8</b>	<b>7</b>	<b>6</b>	<b>5</b>	<b>4</b>	<b>3</b>	<b>2</b>	<b>1</b>	<b>0</b>
<b>Name</b>	PCI subsystem identification															
<b>Type</b>	RU	RU	RU	RU	RU	RU	RU	RU	RU	RU	RU	RU	RU	RU	RU	RU
<b>Default</b>	0	0	0	0	0	0	0	0	0	0	0	0	0	0	0	0

Register: **PCI subsystem identification**  
 Type: Read/Update  
 Offset: 2Ch  
 Default: 0000 0000h  
 Description: This register is used for subsystem and option card identification purposes. This register can be initialized from the serial EEPROM or can be written using the subsystem access register.

**Table 84. PCI Subsystem Identification Register Description**

BIT	FIELD NAME	TYPE	DESCRIPTION
31–16	OHCI_SSID	RU	Subsystem device ID. This field indicates the subsystem device ID.
15–0	OHCI_SSVID	RU	Subsystem vendor ID. This field indicates the subsystem vendor ID.

## PCI power management capabilities pointer register

<b>Bit</b>	<b>7</b>	<b>6</b>	<b>5</b>	<b>4</b>	<b>3</b>	<b>2</b>	<b>1</b>	<b>0</b>
<b>Name</b>	PCI power management capabilities pointer							
<b>Type</b>	R	R	R	R	R	R	R	R
<b>Default</b>	0	1	0	0	0	1	0	0

Register: **PCI power management capabilities pointer**  
 Type: Read-only  
 Offset: 34h  
 Default: 44h  
 Description: This register provides a pointer into the PCI configuration header where the PCI power management register block resides. PCI4450 configuration header double-words at 44h and 48h provide the power management registers. This register is read-only and returns 44h when read.





**interrupt line and pin registers**

Bit	15	14	13	12	11	10	9	8	7	6	5	4	3	2	1	0
Name	Interrupt line and pin															
Type	R	R	R	R	R	R	R	R	R/W	R/W	R/W	R/W	R/W	R/W	R/W	R/W
Default	0	0	0	0	0	0	0	0	0	0	0	0	0	0	0	0

Register: **Interrupt line and pin**  
 Type: Read-only, Read/Write  
 Offset: 3Ch  
 Default: 0000h  
 Description: This register is used to communicate interrupt line routing information.

**Table 85. Interrupt Line and Pin Registers Description**

BIT	FIELD NAME	TYPE	DESCRIPTION
15–8	INTR_PIN	R	Interrupt pin register. This register returns 01h, 02h, or 03h when read, indicating that the PCI4450 link function signals interrupts on INTA, INTB, or INTC pin.
7–0	INTR_LINE	R/W	Interrupt line register. This register is programmed by the system and indicates to the software which interrupt line the PCI4450 INTA is connected.

**MIN\_GNT and MAX\_LAT registers**

Bit	15	14	13	12	11	10	9	8	7	6	5	4	3	2	1	0
Name	MIN_GNT and MAX_LAT															
Type	RU	RU	RU	RU	RU	RU	RU	RU	RU	RU	RU	RU	RU	RU	RU	RU
Default	0	0	0	0	0	0	1	0	0	0	0	0	0	0	1	0

Register: **MIN\_GNT and MAX\_LAT**  
 Type: Read/Update  
 Offset: 3Eh  
 Default: 0202h  
 Description: This register is used to communicate to the system the desired setting of the latency timer register. If a serial ROM is detected, then the contents of this register are loaded through the serial ROM interface after a PCI reset. If no serial ROM is detected, then this register returns a default value that corresponds to the MIN\_GNT = 2, MAX\_LAT = 4.

**Table 86. MIN\_GNT and MAX\_LAT Registers Description**

BIT	FIELD NAME	TYPE	DESCRIPTION
15–8	MAX_LAT	RU	Maximum latency. The contents of this register may be used by host BIOS to assign an arbitration priority-level to the PCI4450. The default for this register indicates that the PCI4450 may need to access the PCI bus as often as every 1/4 μs; thus, an extremely high priority level is requested. The contents of this field may also be loaded through the serial ROM.
7–0	MIN_GNT	RU	Minimum grant. The contents of this register may be used by host BIOS to assign a latency timer register value to the PCI4450. The default for this register indicates that the PCI4450 may need to sustain burst transfers for nearly 64 μs; thus, requesting a large value be programmed in the PCI4450 latency timer register.

# PCI4450 GFN/GJG PC Card and OHCI Controller

SCPS046 – JANUARY 1999

## PCI OHCI control register

Bit	15	14	13	12	11	10	9	8	7	6	5	4	3	2	1	0
Name	PCI OHCI control															
Type	R	R	R	R	R	R	R	R	R	R	R	R	R	R	R	R
Default	0	0	0	0	0	0	0	0	0	0	0	0	0	0	0	0

Register: **PCI OHCI control**  
 Type: Read-only  
 Offset: 40h  
 Default: 0000h  
 Description: This register contains IEEE1394 Open HCI specific control bits. All bits in this register are read-only and return 0s, since no OHCI specific control bits have been implemented.

## capability ID and next item pointer registers

Bit	15	14	13	12	11	10	9	8	7	6	5	4	3	2	1	0
Name	Capability ID and next item pointer															
Type	R	R	R	R	R	R	R	R	R	R	R	R	R	R	R	R
Default	0	0	0	0	0	0	0	0	0	0	0	0	0	0	0	1

Register: **Capability ID and next item pointer**  
 Type: Read-only  
 Offset: 44h  
 Default: 0001h  
 Description: This register identifies the linked list capability item, and provides a pointer to the next capability item.

**Table 87. Capability ID and Next Item Pointer Registers Description**

BIT	FIELD NAME	TYPE	DESCRIPTION
15–8	NEXT_ITEM	R	Next item pointer. The PCI4450 supports only one additional capability that is communicated to the system through the extended capabilities list; thus, this field returns 00h when read.
7–0	CAPABILITY_ID	R	Capability identification. This field returns 01h when read, which is the unique ID assigned by the PCI SIG for PCI power management capability.



**power management capabilities register**

Bit	15	14	13	12	11	10	9	8	7	6	5	4	3	2	1	0
Name	Power management capabilities															
Type	RU	RU	RU	RU	RU	R	R	R	R	R	R	R	R	R	R	R
Default	0	1	0	0	0	0	0	0	0	0	0	0	0	0	0	1

Register: **Power management capabilities**

Type: Read/Update

Offset: 46h

Default: 4001h

Description: This register indicates the capabilities of the PCI4450 related to PCI power management. In summary, the D0, D2, and D3<sub>hot</sub> device states are supported.

**Table 88. Power Management Capabilities Register Description**

BIT	FIELD NAME	TYPE	DESCRIPTION
15	PME_D3COLD	RU	PME support from D3 <sub>cold</sub> . When set, PCI4450 generates a PME wake event from D3 <sub>cold</sub> . This bit state is dependent upon PCI4450 V <sub>aux</sub> implementation and may be configured by host software using the PCI miscellaneous configuration register.
14–11	PME_SUPPORT	RU	PME support. This four-bit field indicates the power states from which the PCI4450 may assert PME. These four bits return a value of 4'b1100 by default, indicating that PME may be asserted from the D3 <sub>hot</sub> and D2 power states. Bit 13 may be modified by host software using the PCI miscellaneous configuration register.
10	D2_SUPPORT	R	D2 support. This bit returns a 1 when read, indicating that the PCI4450 supports the D2 power state.
9	D1_SUPPORT	R	D1 support. This bit returns a 0 when read, indicating that the PCI4450 does not support the D1 power state.
8	DYN_DATA	R	Dynamic data support. This bit returns a 0 when read, indicating that the PCI4450 does not report dynamic power consumption data.
7–6	RSVD	R	Reserved. These bits return 0s when read.
5	DSI	R	Device specific initialization. This bit returns 0 when read, indicating that the PCI4450 does not require special initialization beyond the standard PCI configuration header before a generic class driver is able to use it.
4	AUX_PWR	R	Auxiliary power source. Since the PCI4450 supports PME generation in the D3 <sub>cold</sub> device state and requires V <sub>aux</sub> , this bit returns 1 when read.
3	PME_CLK	R	PME clock. This bit returns 0 when read indicating that no host bus clock is required for the PCI4450 to generate PME.
2–0	PM_VERSION	R	Power management version. This field returns 001b when read, indicating that the PCI4450 is compatible with the registers described in the revision 1.0 <i>PCI Bus Power Management Specification</i> .

# PCI4450 GFN/GJG PC Card and OHCI Controller

SCPS046 – JANUARY 1999

## power management control and status register

Bit	15	14	13	12	11	10	9	8	7	6	5	4	3	2	1	0
Name	Power management control and status															
Type	RC	R	R	R	R	R	R	R/W	R	R	R	R	R	R	R/W	R/W
Default	0	0	0	0	0	0	0	0	0	0	0	0	0	0	0	0

Register: **Power management control and status**  
 Type: Read-only, Read/Write, Read/Clear  
 Offset: 48h  
 Default: 0000h  
 Description: This register implements the control and status of the PCI power management function. This register is not affected by the internally generated reset caused by the transition from the D3<sub>hot</sub> to D0 state.

**Table 89. Power Management Control and Status Register Description**

BIT	FIELD NAME	TYPE	DESCRIPTION
15	PME_STS	RC	This bit is set when the PCI4450 would normally be asserting the $\overline{\text{PME}}$ signal, independent of the state of the PME_ENB bit. This bit is cleared by a write back of 0, and this also clears the $\overline{\text{PME}}$ signal driven by the PCI4450. Writing a 0 to this bit has no effect.
14–9	DYN_CTRL	R	Dynamic data control. This bit field returns 0s when read since the PCI4450 does not report dynamic data.
8	PME_ENB	R/W	$\overline{\text{PME}}$ enable. This bit enables the function to assert $\overline{\text{PME}}$ . If the bit is cleared assertion of $\overline{\text{PME}}$ is disabled.
7–5	RSVD	R	Reserved. These bits return 0s when read.
4	DYN_DATA	R	Dynamic data. This bit returns 0 when read since the PCI4450 does not report dynamic data.
3–2	RSVD	R	Reserved. These bits return 0s when read.
1–0	PWR_STATE	R/W	Power state. This two-bit field is used to set the PCI4450 device power state, and is encoded as follows: 00 = Current power state is D0 01 = Current power state is D1 10 = Current power state is D2 11 = Current power state is D3 <sub>hot</sub>



**power management extension register**

<b>Bit</b>	15	14	13	12	11	10	9	8	7	6	5	4	3	2	1	0
<b>Name</b>	Power management extension															
<b>Type</b>	R	R	R	R	R	R	R	R	R	R	R	R	R	R	R	R
<b>Default</b>	0	0	0	0	0	0	0	0	0	0	0	0	0	0	0	0

Register: **Power management extension**

Type: Read-only

Offset: 4Ah

Default: 0000h

Description: This register provides extended power management features not applicable to the PCI4450, thus it is read-only and returns 0 when read.

**Table 90. Power Management Extension Register Description**

BIT	FIELD NAME	TYPE	DESCRIPTION
15–8	PM_DATA	R	Power management data. This bit field returns 0s when read since the PCI4450 does not report dynamic data.
7–0	PMCSR_BSE	R	Power management CSR – bridge support extensions. This field returns 0s since the PCI4450 does not provide P2P bridging.

# PCI4450 GFN/GJG PC Card and OHCI Controller

SCPS046 – JANUARY 1999

## PCI miscellaneous configuration register

Bit	31	30	29	28	27	26	25	24	23	22	21	20	19	18	17	16
Name	PCI miscellaneous configuration															
Type	R	R	R	R	R	R	R	R	R	R	R	R	R	R	R	R
Default	0	0	0	0	0	0	0	0	0	0	0	0	0	0	0	0
Bit	15	14	13	12	11	10	9	8	7	6	5	4	3	2	1	0
Name	PCI miscellaneous configuration															
Type	R/W	R	R/W	R	R	R/W	R	R	R	R	R	R	R/W	R/W	R/W	R/W
Default	0	0	1	0	0	1	0	0	0	0	0	0	0	0	0	0

Register: **PCI miscellaneous configuration**  
 Type: Read-only, Read/Write  
 Offset: F0h  
 Default: 0000 2400h  
 Description: This register provides miscellaneous PCI-related configuration.

**Table 91. PCI Miscellaneous Configuration Register Description**

BIT	FIELD NAME	TYPE	DESCRIPTION
31–16	RSVD	R	Reserved. These bits return 0s when read.
15	PME_D3COLD	R/W	$\overline{\text{PME}}$ support from D3 <sub>cold</sub> . This bit is used to program the corresponding read-only value read from power management capabilities. This bit retains state through PCI reset and D3 – D0 transitions.
14	RSVD	R	Reserved. This bit returns 0 when read.
13	PME_SUPPORT_D2	R/W	$\overline{\text{PME}}$ support. This bit is used to program the corresponding read-only value read from power management capabilities. If wake from the D2 power state implemented in PCI4450 is not desired, then this bit may be cleared to indicate to power management software that wake-up from D2 is not supported. This bit retains state through PCI reset and D3 – D0 transitions.
12–11	RSVD	R	Reserved. These bits return 0s when read.
10	D2_SUPPORT	R/W	D2 support. This bit is used to program the corresponding read-only value read from power management capabilities. If the D2 power state implemented in PCI4450 is not desired, then this bit may be cleared to indicate to power management software that D2 is not supported. This bit retains state through PCI reset and D3 – D0 transitions.
9–4	RSVD	R	Reserved. These bits return 0s when read.
3	RSVD	R/W	Reserved. This bit defaults to 0.
2	DISABLE_SCLKGATE	R/W	When set, the internal SCLK runs identically with the chip input.
1	DISABLE_PCIGATE	R/W	When set, the internal PCI clock runs identically with the chip input.
0	KEEP_PCLK	R/W	When set, the PCI clock is always kept running through the CLKRUN protocol. When cleared, the PCI clock may be stopped using CLKRUN.



link enhancement control register

Bit	31	30	29	28	27	26	25	24	23	22	21	20	19	18	17	16
Name	Link enhancement control															
Type	R	R	R	R	R	R	R	R	R	R	R	R	R	R	R	R
Default	0	0	0	0	0	0	0	0	0	0	0	0	0	0	0	0
Bit	15	14	13	12	11	10	9	8	7	6	5	4	3	2	1	0
Name	Link enhancement control															
Type	R	R	R/W	R/W	R	R	R/W	R/W	R/W	R	R	R	R	R/W	R/W	R
Default	0	0	0	1	0	0	0	0	0	0	0	0	0	0	0	0

Register: **Link enhancement control**

Type: Read-only, Read/Write

Offset: F4h

Default: 0000 1000h

Description: This register implements TI proprietary bits that are initialized by software or by a serial EEPROM if present. After these bits are set, their functionality is enabled only if the aPhyEnhanceEnable bit in the HCControl register is set.

Table 92. Link Enhancement Control Register Description

BIT	FIELD NAME	TYPE	DESCRIPTION
31–14	RSVD	R	Reserved. These bits return 0s when read.
13–12	atx_thresh	R/W	This bit field sets the initial AT threshold value, which is used until the AT FIFO is underrun. When PCI4450 retries the packet, it uses a 2K-byte threshold resulting in store-and-forward operation. 00 = Threshold ~ 2 Kbytes resulting in store-and-forward operation 01 = Threshold ~ 1.7 Kbytes (default) 10 = Threshold ~ 1 K 11 = Threshold ~ 512 bytes
11–10	RSVD	R	Reserved. This bit returns 0 when read.
9	enab_audio_ts	R/W	Enable audio/music CIP timestamp enhancement. When this bit is set, the enhancement is enabled for audio/music CIP transmit streams (FMT = 6'h10).
8	enab_dv_ts	R/W	Enable DV CIP timestamp enhancement. When this bit is set, the enhancement is enabled for DV CIP transmit streams (FMT = 6'h00).
7	enab_unfair	R/W	Enable asynchronous priority requests. OHCIlynx (TSB12LV22) compatible.
6	RSVD	R	This reserved field will not be assigned in PCI4450 follow-on products since this bit location loaded by the serial ROM from the <i>enhancements</i> field corresponds to HCControl.programPhyEnable in Open HCI register space.
5–3	RSVD	R	Reserved. These bits return 0s when read.
2	enab_insert_idle	R/W	Enable insert idle. OHCIlynx (TSB12LV22) compatible.
1	enab_accel	R/W	Enable acceleration enhancements. OHCIlynx (TSB12LV22) compatible.
0	RSVD	R	Reserved. This bit returns 0 when read.

# PCI4450 GFN/GJG PC Card and OHCI Controller

SCPS046 – JANUARY 1999

## subsystem access register

<b>Bit</b>	<b>31</b>	<b>30</b>	<b>29</b>	<b>28</b>	<b>27</b>	<b>26</b>	<b>25</b>	<b>24</b>	<b>23</b>	<b>22</b>	<b>21</b>	<b>20</b>	<b>19</b>	<b>18</b>	<b>17</b>	<b>16</b>
<b>Name</b>	Subsystem access identification															
<b>Type</b>	R/W	R/W	R/W	R/W	R/W	R/W	R/W	R/W	R/W	R/W	R/W	R/W	R/W	R/W	R/W	R/W
<b>Default</b>	0	0	0	0	0	0	0	0	0	0	0	0	0	0	0	0
<b>Bit</b>	<b>15</b>	<b>14</b>	<b>13</b>	<b>12</b>	<b>11</b>	<b>10</b>	<b>9</b>	<b>8</b>	<b>7</b>	<b>6</b>	<b>5</b>	<b>4</b>	<b>3</b>	<b>2</b>	<b>1</b>	<b>0</b>
<b>Name</b>	Subsystem access identification															
<b>Type</b>	R/W	R/W	R/W	R/W	R/W	R/W	R/W	R/W	R/W	R/W	R/W	R/W	R/W	R/W	R/W	R/W
<b>Default</b>	0	0	0	0	0	0	0	0	0	0	0	0	0	0	0	0

Register: **Subsystem access identification**

Type: Read/Write

Offset: F8h

Default: 0000 0000h

Description: This register is used for system and option card identification purposes. The contents of this register are aliased to subsystem identification register at address 2Ch.

**Table 93. Subsystem Access Identification Register Description**

<b>BIT</b>	<b>FIELD NAME</b>	<b>TYPE</b>	<b>DESCRIPTION</b>
31–16	SUBDEV_ID	R/W	Subsystem device ID. This field indicates the subsystem device ID.
15–0	SUBVEN_ID	R/W	Subsystem vendor ID. This field indicates the subsystem vendor ID.





**GPIO control register**

<b>Bit</b>	<b>31</b>	<b>30</b>	<b>29</b>	<b>28</b>	<b>27</b>	<b>26</b>	<b>25</b>	<b>24</b>	<b>23</b>	<b>22</b>	<b>21</b>	<b>20</b>	<b>19</b>	<b>18</b>	<b>17</b>	<b>16</b>
<b>Name</b>	GPIO control															
<b>Type</b>	R	R	R/W	R/W	R	R	R	R/W	R	R	R/W	R/W	R	R	R	R/W
<b>Default</b>	0	0	0	0	0	0	0	0	0	0	0	0	0	0	0	0
<b>Bit</b>	<b>15</b>	<b>14</b>	<b>13</b>	<b>12</b>	<b>11</b>	<b>10</b>	<b>9</b>	<b>8</b>	<b>7</b>	<b>6</b>	<b>5</b>	<b>4</b>	<b>3</b>	<b>2</b>	<b>1</b>	<b>0</b>
<b>Name</b>	GPIO control															
<b>Type</b>	R/W	R	R/W	R/W	R	R	R	R/W	R/W	R	R/W	R/W	R	R	R	R/W
<b>Default</b>	0	0	0	1	0	0	0	0	0	0	0	1	0	0	0	0

Register: **GPIO control**  
 Type: Read-only, Read/Write  
 Offset: FCh  
 Default: 0000 1010h

Description: This register has the control and status bits for GPIO0, GPIO1, GPIO2 and GPIO3 ports. Upon reset, GPIO0 and GPIO1 default to bus manager contender (BMC) and link power status terminals, respectively. The BMC terminal can be configured as GPIO0 by setting the disable\_BMC bit to 1. The LPS terminal can be configured as GPIO1 by setting the disable\_LPS bit to 1.

**Table 94. General-Purpose Input/Output Control Register Description**

BIT	FIELD NAME	TYPE	DESCRIPTION
31–30	RSVD	R	Reserved. These bits return 0s when read.
29	GPIO_INV3	R/W	GPIO3 polarity invert. This bit controls the input/output polarity control of GPIO3. 0 = noninverted (default) 1 = inverted
28	GPIO_ENB3	R/W	GPIO3 enable control. This bit controls the output enable for GPIO3 0 = high-impedance output (default) 1 = output enabled
27–25	RSVD	R	Reserved. These bits return 0s when read.
24	GPIO_DATA3	R/W	GPIO3 data. When GPIO3 output is enabled, the value written to this bit represents the logical data driven to the GPIO3 terminal.
23–22	RSVD	R	Reserved. These bits return 0s when read.
21	GPIO_INV2	R/W	GPIO2 polarity invert. This bit controls the input/output polarity control of GPIO2. 0 = noninverted (default) 1 = inverted
20	GPIO_ENB2	R/W	GPIO2 enable control. This bit controls the output enable for GPIO2. 0 = high-impedance output (default) 1 = output enabled
19–17	RSVD	R	Reserved. These bits return 0s when read.
16	GPIO_DATA2	R/W	GPIO2 data. When GPIO2 output is enabled, the value written to this bit represents the logical data driven to the GPIO2 terminal.
15	DISABLE_LPS	R/W	Disable link power status (LPS). This bit configures this terminal as 0 = LPS (default) 1 = GPIO1
14	RSVD	R	Reserved. This bit returns 0 when read.

# PCI4450 GFN/GJG PC Card and OHCI Controller

SCPS046 – JANUARY 1999

**Table 94. General-Purpose Input/Output Control Register Description (Continued)**

BIT	FIELD NAME	TYPE	DESCRIPTION
13	GPIO_INV1	R/W	GPIO1 polarity invert. When DISABLE_LPS bit is set to 1, this bit controls the input output polarity control of GPIO1 0 = noninverted (default) 1 = inverted
12	GPIO_ENB1	R/W	GPIO1 enable control. When DISABLE_LPS bit is set to 1, this bit controls the output enable for GPIO1 0 = high-impedance output 1 = output enabled (default)
11–9	RSVD	R	Reserved. These bits return 0s when read.
8	GPIO_DATA1	R/W	GPIO1 data. When DISABLE_LPS bit is set to 1 and GPIO1 output is enabled, the value written to this bit represents the logical data driven to the GPIO1 terminal.
7	DISABLE_BMC	R/W	Disable bus manager contender (BMC). This bit configures this terminals as bus master contender or GPIO. 0 = BMC (default) 1 = GPIO0
6	RSVD	R	Reserved. This bit returns 0 when read.
5	GPIO_INV0	R/W	GPIO0 polarity invert. When DISABLE_BMC bit is set to 1, this bit controls the input output polarity control of for GPIO0 0 = non-inverted (default) 1 = inverted
4	GPIO_ENB0	R/W	GPIO0 enable control. When DISABLE_BMC bit is set to 1, this bit controls the output enable for GPIO0 0 = high-impedance output 1 = output enabled (default)
3–1	RSVD	R	Reserved. These bits return 0s when read.
0	GPIO_DATA0	R/W	GPIO0 data. When DISABLE_BMC bit is set to 1 and GPIO0 output is enabled, the value written to this bit represents the logical data driven to the GPIO0 terminal.



**link timer adjustment register**

<b>Bit</b>	31	30	29	28	27	26	25	24	23	22	21	20	19	18	17	16
<b>Name</b>	Link timer adjustment															
<b>Type</b>	R	R	R	R	R	R	R	R	R	R	R	R	R	R	R	R
<b>Default</b>	0	0	0	0	0	0	0	0	0	0	0	0	0	0	0	0
<b>Bit</b>	15	14	13	12	11	10	9	8	7	6	5	4	3	2	1	0
<b>Name</b>	Link timer adjustment															
<b>Type</b>	R	R	R	R	R	R	R	R	R	R	R	R	R/W	R/W	R/W	R/W
<b>Default</b>	0	0	0	0	0	0	0	0	0	0	0	0	0	0	0	0

Register: **Link timer adjustment**

Type: Read-only, Read/Write

Offset: C10h

Default: 0000 0000h

Description: This register is used to control the link rollover value, and should be programmed with a non-zero value only when PCI4450 is the 1394 cycle master.

**Table 95. Link Timer Adjustment Register Description**

<b>BIT</b>	<b>FIELD NAME</b>	<b>TYPE</b>	<b>DESCRIPTION</b>
31–8	RSVD	R	Reserved. These bits return 0s when read.
7	TIMER_ADJ_REQ	R	This bit indicates that the timer adjust request is active, but not completed. This bit is set whenever the timer adjust field is written, and is cleared when the actual adjustment is made.
6–4	RSVD	R	Reserved. These bits return 0s when read.
3–0	TIMER_ADJ_VAL	R/W	Cycle timer adjustment value. This four bit signed value is used to adjust the PCI4450 cycleTimer. The cycle timer offset field may be adjusted from +7 to –8 using this register.

**open HCI registers**

The open HCI registers defined by the *IEEE1394 Open HCI Specification* are memory mapped into a 2-Kbyte region of memory pointed to by the OHCI base address register at offset 10h in PCI configuration space. These registers are the primary interface for controlling the PCI4450 IEEE1394 link function.

This section provides the register interface and bit descriptions. There are several set and clear register pairs in this programming model, which are implemented to solve various issues with typical read-modify-write control registers. There are two addresses for a set/clear register: RegisterSet and RegisterClear. Refer to Table 96 for an illustration. A 1 written to RegisterSet causes the corresponding bit in the set/clear register to be set, while a 0 leaves the corresponding bit unaffected. A 1 written to RegisterClear causes the corresponding bit in the set/clear register to be reset, while a 0 leaves the corresponding bit in the set/clear register unaffected.

Typically, a read from either RegisterSet or RegisterClear returns the value of the set/clear register. However, sometimes reading the RegisterClear will provide a masked version of the set/clear register. The interrupt event register is an example of this behavior.

**Table 96. Open HCI Register Map**

DMA CONTEXT	REGISTER NAME	ABBREVIATION	OFFSET
—	OHCI version	Version	00h
	Global unique ID ROM	GUID_ROM	04h
	Asynchronous transmit retries	ATRetries	08h
	CSR data	CSRData	0Ch
	CSR compare data	CSRCompareData	10h
	CSR control	CSRControl	14h
	Configuration ROM header	ConfigROMhdr	18h
	Bus identification	BusID	1Ch
	Bus options	BusOptions	20h
	Global unique ID high	GUIDHi	24h
	Global unique ID low	GUIDLo	28h
	Reserved	—	2Ch
	Reserved	—	30h
	Configuration ROM map	ConfigROMmap	34h
	Posted write address low	PostedWriteAddressLo	38h
	Posted write address high	PostedWriteAddressHi	3Ch
	Vendor identification	VendorID	40h
	Reserved	—	44h – 4Ch

Table 96. Open HCI Register Map (Continued)

DMA CONTEXT	REGISTER NAME	ABBREVIATION	OFFSET
—	Host controller control	HCCControlSet	50h
		HCCControlClr	54h
	Reserved	—	58h
	Reserved	—	5Ch
Self ID	Reserved	—	60h
	Self ID buffer	SelfIDBuffer	64h
	Self ID count	SelfIDCount	68h
	Reserved	—	6Ch
—	Isochronous receive channel mask high	IRChannelMaskHiSet	70h
		IRChannelMaskHiClear	74h
	Isochronous receive channel mask low	IRChannelMaskLoSet	78h
		IRChannelMaskLoClear	7Ch
	Interrupt event	IntEventSet	80h
		IntEventClear	84h
	Interrupt mask	IntMaskSet	88h
		IntMaskClear	8Ch
	Isochronous transmit interrupt event	IsoXmitIntEventSet	90h
		IsoXmitIntEventClear	94h
	Isochronous transmit interrupt mask	IsoXmitIntMaskSet	98h
		IsoXmitIntMaskClear	9Ch
—	Isochronous receive interrupt event	IsoRecvIntEventSet	A0h
		IsoRecvIntEventClear	A4h
	Isochronous receive interrupt mask	IsoRecvIntMaskSet	A8h
		IsoRecvIntMaskClear	ACh
	Reserved	—	B0–D8h
	Fairness control	FairnessControl	DCh
	Link control	LinkControlSet	E0h
		LinkControlClear	E4h
	Node identification	NodeID	E8h
	Phy layer control	PhyControl	ECh
	Isochronous cycle timer	IsoCycleTimer	F0h
	Reserved	—	F4h – FCh
	Asynchronous request filter high	AsyncRequestFilterHiSet	100h
		AsyncRequestFilterHiClear	104h
	Asynchronous request filter low	AsyncRequestFilterLoSet	108h
		AsyncRequestFilterloClear	10Ch
	Physical request filter high	PhysicalRequestFilterHiSet	110h
		PhysicalRequestFilterHiClear	114h
	Physical request filter low	PhysicalRequestFilterLoSet	118h
		PhysicalRequestFilterloClear	11Ch
Physical upper bound	PhysicalUpperBound	120h	
Reserved	—	124h – 17Ch	

# PCI4450 GFN/GJG PC Card and OHCI Controller

SCPS046 – JANUARY 1999

**Table 96. Open HCI Register Map (Continued)**

DMA CONTEXT	REGISTER NAME	ABBREVIATION	OFFSET
Asynchronous request transmit [ ATRQ ]	Context control	ContextControlSet	180h
		ContextControlClear	184h
	Reserved	—	188h
	Command pointer	CommandPtr	18Ch
Asynchronous response transmit [ ATRS ]	Reserved	—	190h – 19Ch
	Context control	ContextControlSet	1A0h
		ContextControlClear	1A4h
	Reserved	—	1A8h
Command pointer	CommandPtr	1ACh	
Asynchronous request receive [ ARRQ ]	Reserved	—	1B0h – 1BCh
	Context control	ContextControlSet	1C0h
		ContextControlClear	1C4h
	Reserved	—	1C8h
Command pointer	CommandPtr	1CCh	
Asynchronous response receive [ ARRS ]	Reserved	—	1D0h – 1DCh
	Context control	ContextControlSet	1E0h
		ContextControlClear	1E4h
	Reserved	—	1E8h
Command pointer	CommandPtr	1ECh	
Isochronous transmit context n n = 0, 1, 2, 3, ... 7	Reserved	—	1F0h – 1FCh
	Context control	ContextControlSet	200h + 16*n
		ContextControlClear	204h + 16*n
Reserved	—	208h + 16*n	
Isochronous receive context n n = 0, 1, 2, 3, 4	Command pointer	CommandPtr	20Ch + 16*n
	Context control	ContextControlSet	400h + 32*n
		ContextControlClear	404h + 32*n
	Reserved	—	408h + 32*n
Command pointer	CommandPtr	40Ch + 32*n	
	Context match	ContextMatch	410h + 32*n



**OHCI version register**

<b>Bit</b>	31	30	29	28	27	26	25	24	23	22	21	20	19	18	17	16
<b>Name</b>	OHCI version															
<b>Type</b>	R	R	R	R	R	R	R	R	R	R	R	R	R	R	R	R
<b>Default</b>	0	0	0	0	0	0	0	0	0	0	0	0	0	0	0	0
<b>Bit</b>	15	14	13	12	11	10	9	8	7	6	5	4	3	2	1	0
<b>Name</b>	OHCI version															
<b>Type</b>	R	R	R	R	R	R	R	R	R	R	R	R	R	R	R	R
<b>Default</b>	0	0	0	0	0	0	0	0	0	0	0	0	0	0	0	0

Register: **OHCI version**

Type: Read-only

Offset: 00h

Default: 0X01 0000h

Description: This register indicates the OHCI version support, and whether or not the serial ROM is present.

**Table 97. OHCI Version Register Description**

BIT	FIELD NAME	TYPE	DESCRIPTION
31–25	RSVD	R	Reserved. These bits return 0s when read.
24	GUID_ROM	R	The PCI4450 sets this bit if the serial ROM is detected. If the serial ROM is present, then the Bus_Info_Block will be automatically loaded on hardware reset.
23–16	version	R	Major version of the Open HCI. The PCI4450 is compliant with the OHCI specification version 1.00; thus, this field reads 8'h01.
15–8	RSVD	R	Reserved. These bits return 0s when read.
7–0	revision	R	Minor version of the Open HCI. The PCI4450 is compliant with the OHCI specification version 1.00; thus, this field reads 8'h00.

# PCI4450 GFN/GJG PC Card and OHCI Controller

SCPS046 – JANUARY 1999

## GUID ROM register

<b>Bit</b>	<b>31</b>	<b>30</b>	<b>29</b>	<b>28</b>	<b>27</b>	<b>26</b>	<b>25</b>	<b>24</b>	<b>23</b>	<b>22</b>	<b>21</b>	<b>20</b>	<b>19</b>	<b>18</b>	<b>17</b>	<b>16</b>
<b>Name</b>	GUID ROM															
<b>Type</b>	RSU	R	R	R	R	R	RSU	R	RU	RU	RU	RU	RU	RU	RU	RU
<b>Default</b>	0	0	0	0	0	0	0	0	X	X	X	X	X	X	X	X
<b>Bit</b>	<b>15</b>	<b>14</b>	<b>13</b>	<b>12</b>	<b>11</b>	<b>10</b>	<b>9</b>	<b>8</b>	<b>7</b>	<b>6</b>	<b>5</b>	<b>4</b>	<b>3</b>	<b>2</b>	<b>1</b>	<b>0</b>
<b>Name</b>	GUID ROM															
<b>Type</b>	R	R	R	R	R	R	R	R	R	R	R	R	R	R	R	R
<b>Default</b>	0	0	0	0	0	0	0	0	0	0	0	0	0	0	0	0

Register: **GUID ROM**  
 Type: Read-only, Read/Set/Update, Read/Update  
 Offset: 04h  
 Default: 00XX 0000h  
 Description: This register is used to access the serial ROM, and is only applicable if the Version.GUID\_ROM bit is set.

**Table 98. GUID ROM Register Description**

<b>BIT</b>	<b>FIELD NAME</b>	<b>TYPE</b>	<b>DESCRIPTION</b>
31	addrReset	RSU	Software sets this bit to reset the GUID ROM address to 0. When the PCI4450 completes the reset, it clears this bit. The PCI4450 does not automatically fill rdData with the 0 <sup>th</sup> byte.
30–26	RSVD	R	Reserved. These bits return 0s when read.
25	rdStart	RSU	A read of the currently addressed byte is started when this bit is set. This bit is automatically cleared when the PCI4450 completes the read of the currently addressed GUID ROM byte.
24	RSVD	R	Reserved. This bit returns 0 when read.
23–16	rdData	RU	This field represents the data read from the GUID ROM.
15–0	RSVD	R	Reserved. These bits return 0s when read.





**asynchronous transmit retries register**

<b>Bit</b>	31	30	29	28	27	26	25	24	23	22	21	20	19	18	17	16
<b>Name</b>	Asynchronous transmit retries															
<b>Type</b>	R	R	R	R	R	R	R	R	R	R	R	R	R	R	R	R
<b>Default</b>	0	0	0	0	0	0	0	0	0	0	0	0	0	0	0	0
<b>Bit</b>	15	14	13	12	11	10	9	8	7	6	5	4	3	2	1	0
<b>Name</b>	Asynchronous transmit retries															
<b>Type</b>	R	R	R	R	R/W	R/W	R/W	R/W	R/W	R/W	R/W	R/W	R/W	R/W	R/W	R/W
<b>Default</b>	0	0	0	0	0	0	0	0	0	0	0	0	0	0	0	0

Register: **Asynchronous transmit retries**

Type: Read-only, Read/Write

Offset: 08h

Default: 0000 0000h

Description: This register indicates the number of times the PCI4450 will attempt a retry for asynchronous DMA request transmit and for asynchronous physical and DMA response transmit.

**Table 99. Asynchronous Transmit Retries Register Description**

BIT	FIELD NAME	TYPE	DESCRIPTION
31–29	secondLimit	R	The second limit field returns 0s when read, since outbound dual-phase retry is not implemented.
28–16	cycleLimit	R	The cycle limit field returns 0s when read, since outbound dual-phase retry is not implemented.
15–12	RSVD	R	Reserved. These bits return 0s when read.
11–8	maxPhysRespRetries	R/W	The maxPhysRespRetries field tells the physical response unit how many times to attempt to retry the transmit operation for the response packet when a busy acknowledge or ack_data_error is received from the target node.
7–4	maxATRespRetries	R/W	The maxATRespRetries field tells the asynchronous transmit response unit how many times to attempt to retry the transmit operation for the response packet when a busy acknowledge or ack_data_error is received from the target node.
3–0	maxATReqRetries	R/W	The maxATReqRetries field tells the asynchronous transmit DMA request unit how many times to attempt to retry the transmit operation for the response packet when a busy acknowledge or ack_data_error is received from the target node.

# PCI4450 GFN/GJG PC Card and OHCI Controller

SCPS046 – JANUARY 1999

## CSR data register

Bit	31	30	29	28	27	26	25	24	23	22	21	20	19	18	17	16
Name	CSR data															
Type	R	R	R	R	R	R	R	R	R	R	R	R	R	R	R	R
Default	0	0	0	0	0	0	0	0	0	0	0	0	0	0	0	0
Bit	15	14	13	12	11	10	9	8	7	6	5	4	3	2	1	0
Name	CSR data															
Type	R	R	R	R	R	R	R	R	R	R	R	R	R	R	R	R
Default	0	0	0	0	0	0	0	0	0	0	0	0	0	0	0	0

Register: **CSR data**  
 Type: Read-only  
 Offset: 0Ch  
 Default: XXXX XXXXh  
 Description: This register is used to access the bus management CSR registers from the host through compare-swap operations. This register contains the data to be stored in a CSR if the compare is successful.

## CSR compare register

Bit	31	30	29	28	27	26	25	24	23	22	21	20	19	18	17	16
Name	CSR compare															
Type	R	R	R	R	R	R	R	R	R	R	R	R	R	R	R	R
Default	0	0	0	0	0	0	0	0	0	0	0	0	0	0	0	0
Bit	15	14	13	12	11	10	9	8	7	6	5	4	3	2	1	0
Name	CSR compare															
Type	R	R	R	R	R	R	R	R	R	R	R	R	R	R	R	R
Default	0	0	0	0	0	0	0	0	0	0	0	0	0	0	0	0

Register: **CSR compare**  
 Type: Read-only  
 Offset: 10h  
 Default: XXXX XXXXh  
 Description: This register is used to access the bus management CSR registers from the host through compare-swap operations. This register contains the data to be compared with the existing value of the CSR resource.



**CSR control register**

<b>Bit</b>	31	30	29	28	27	26	25	24	23	22	21	20	19	18	17	16
<b>Name</b>	CSR control															
<b>Type</b>	RU	R	R	R	R	R	R	R	R	R	R	R	R	R	R	R
<b>Default</b>	0	0	0	0	0	0	0	0	0	0	0	0	0	0	0	0
<b>Bit</b>	15	14	13	12	11	10	9	8	7	6	5	4	3	2	1	0
<b>Name</b>	CSR control															
<b>Type</b>	R	R	R	R	R	R	R	R	R	R	R	R	R	R	R/W	R/W
<b>Default</b>	0	0	0	0	0	0	0	0	0	0	0	0	0	0	X	X

Register: **CSR control**  
 Type: Read-only, Read/Update, Read/Write  
 Offset: 14h  
 Default: 0000 0000h  
 Description: This register is used to access the bus management CSR registers from the host through compare-swap operations. This register is used to control the compare-swap operation and select the CSR resource.

**Table 100. CSR Control Register Description**

<b>BIT</b>	<b>FIELD NAME</b>	<b>TYPE</b>	<b>DESCRIPTION</b>
31	csrDone	RU	This bit is set by the PCI4450 when a compare-swap operation is complete. It is reset whenever this register is written.
30–2	RSVD	R	Reserved. These bits return 0s when read.
1–0	csrSel	R/W	This field selects the CSR resource as follows: 00 = BUS_MANAGER_ID 01 = BANDWIDTH_AVAILABLE 10 = CHANNELS_AVAILABLE_HI 11 = CHANNELS_AVAILABLE_LO

# PCI4450 GFN/GJG PC Card and OHCI Controller

SCPS046 – JANUARY 1999

## configuration ROM header register

Bit	31	30	29	28	27	26	25	24	23	22	21	20	19	18	17	16
Name	Configuration ROM header															
Type	R/W	R/W	R/W	R/W	R/W	R/W	R/W	R/W	R/W	R/W	R/W	R/W	R/W	R/W	R/W	R/W
Default	0	0	0	0	0	0	0	0	0	0	0	0	0	0	0	0
Bit	15	14	13	12	11	10	9	8	7	6	5	4	3	2	1	0
Name	Configuration ROM header															
Type	R/W	R/W	R/W	R/W	R/W	R/W	R/W	R/W	R/W	R/W	R/W	R/W	R/W	R/W	R/W	R/W
Default	X	X	X	X	X	X	X	X	X	X	X	X	X	X	X	X

Register: **Configuration ROM header**  
 Type: Read/Write  
 Offset: 18h  
 Default: 0000 XXXXh  
 Description: This register externally maps to the first quadlet of the 1394 configuration ROM, offset 48'hFFFF\_F000\_0400.

**Table 101. Configuration ROM Header Register Description**

BIT	FIELD NAME	TYPE	DESCRIPTION
31–24	info_length	R/W	IEEE1394 bus mgmt field. Must be valid when HCControl.linkEnable bit is set.
23–16	crc_length	R/W	IEEE1394 bus mgmt field. Must be valid when HCControl.linkEnable bit is set.
15–0	rom_crc_value	R/W	IEEE1394 bus management field. Must be valid at any time the HCControl.linkEnable bit is set. The reset value is undefined if no serial ROM is present. If a serial ROM is present, then this field is loaded from the serial ROM.

## bus identification register

Bit	31	30	29	28	27	26	25	24	23	22	21	20	19	18	17	16
Name	Bus identification															
Type	R	R	R	R	R	R	R	R	R	R	R	R	R	R	R	R
Default	0	0	1	1	0	0	0	1	0	0	1	1	0	0	1	1
Bit	15	14	13	12	11	10	9	8	7	6	5	4	3	2	1	0
Name	Bus identification															
Type	R	R	R	R	R	R	R	R	R	R	R	R	R	R	R	R
Default	0	0	1	1	1	0	0	1	0	0	1	1	0	1	0	0

Register: **Bus identification**  
 Type: Read-only  
 Offset: 1Ch  
 Default: 3133 3934h  
 Description: This register externally maps to the first quadlet in the Bus\_Info\_Block, and contains the constant 32'h31333934, which is the ASCII value of 1394.



bus options register

Bit	31	30	29	28	27	26	25	24	23	22	21	20	19	18	17	16
Name	Bus options															
Type	R/W	R/W	R/W	R/W	R/W	R	R	R	R/W	R/W	R/W	R/W	R/W	R/W	R/W	R/W
Default	X	X	X	X	0	0	0	0	X	X	X	X	X	X	X	X
Bit	15	14	13	12	11	10	9	8	7	6	5	4	3	2	1	0
Name	Bus options															
Type	R/W	R/W	R/W	R/W	R	R	R	R	R/W	R/W	R	R	R	R	R	R
Default	1	0	1	0	0	0	0	0	X	X	0	0	0	0	1	0

Register: **Bus options**  
 Type: Read-only, Read/Write  
 Offset: 20h  
 Default: X0XX A0X2h  
 Description: This register externally maps to the second quadlet of the Bus\_Info\_Block.

Table 102. Bus Options Register Description

BIT	FIELD NAME	TYPE	DESCRIPTION
31	irmc	R/W	Isochronous resource manager capable. IEEE1394 bus management field. Must be valid when HCControl.linkEnable bit is set.
30	cmc	R/W	Cycle master capable. IEEE1394 bus management field. Must be valid when HCControl.linkEnable bit is set.
29	isc	R/W	Isochronous support capable. IEEE1394 bus management field. Must be valid when HCControl.linkEnable bit is set.
28	bmc	R/W	Bus manager capable. IEEE1394 bus management field. Must be valid when HCControl.linkEnable bit is set.
27	pmc	R/W	IEEE1394 bus management field. Must be valid when HCControl.linkEnable bit is set.
26–24	RSVD	R	Reserved. These bits return 0s when read.
23–16	cyc_clk_acc	R/W	Cycle master clock accuracy. (accuracy in parts per million) IEEE1394 bus management field. Must be valid when HCControl.linkEnable bit is set.
15–12	max_rec	R/W	IEEE 1394 bus management field. Hardware shall initialize max_rec to indicate the maximum number of bytes in a block request packet that is supported by the implementation. This value, max_rec_bytes must be 512 greater, and is calculated by $2^{(max\_rec + 1)}$ . Software may change max_rec, however this field must be valid at any time the HCControl.linkEnable bit is set. A received block write request packet with a length greater than max_rec_bytes may generate an ack_type_error. This field is not affected by a soft reset, and defaults to value indicating 2048 bytes on hard reset.
11–8	RSVD	R	Reserved. These bits return 0s when read.
7–6	g	R/W	Generation counter. This field shall be incremented is any portion the configuration ROM has incremented since the prior bus reset.
5–3	RSVD	R	Reserved. These bits return 0s when read.
2–0	Lnk_spd	R	Link speed. This field returns 010, indicating that the link speeds of 100, 200 and 400 Mbits/s are supported.

# PCI4450 GFN/GJG PC Card and OHCI Controller

SCPS046 – JANUARY 1999

## GUID high register

Bit	31	30	29	28	27	26	25	24	23	22	21	20	19	18	17	16
Name	GUID high															
Type	R	R	R	R	R	R	R	R	R	R	R	R	R	R	R	R
Default	0	0	0	0	0	0	0	0	0	0	0	0	0	0	0	0
Bit	15	14	13	12	11	10	9	8	7	6	5	4	3	2	1	0
Name	GUID high															
Type	R	R	R	R	R	R	R	R	R	R	R	R	R	R	R	R
Default	0	0	0	0	0	0	0	0	0	0	0	0	0	0	0	0

Register: **GUID high**

Type: Read-only

Offset: 24h

Default: 0000 0000h

Description: This register represents the upper quadlet in a 64-bit global unique ID (GUID) which maps to the third quadlet in the Bus\_Info\_Block. This register contains node\_vendor\_ID and chip\_ID\_hi fields. This register initializes to 0s on a hardware reset, which is an illegal GUID value. If a serial ROM is detected, then the contents of this register are loaded through the serial ROM interface after a PCI reset. At that point, the contents of this register cannot be changed. If no serial ROM is detected, then this register may be written once to set the value of this register. At that point, the contents of this register cannot be changed.

## GUID low register

Bit	31	30	29	28	27	26	25	24	23	22	21	20	19	18	17	16
Name	GUID low															
Type	R	R	R	R	R	R	R	R	R	R	R	R	R	R	R	R
Default	0	0	0	0	0	0	0	0	0	0	0	0	0	0	0	0
Bit	15	14	13	12	11	10	9	8	7	6	5	4	3	2	1	0
Name	GUID low															
Type	R	R	R	R	R	R	R	R	R	R	R	R	R	R	R	R
Default	0	0	0	0	0	0	0	0	0	0	0	0	0	0	0	0

Register: **GUID low**

Type: Read-only

Offset: 28h

Default: 0000 0000h

Description: This register represents the lower quadlet in a 64-bit global unique ID (GUID) which maps to chip\_ID\_lo in the Bus\_Info\_Block. This register initializes to 0s on a hardware reset, and behaves identical to the GUID high register.



**configuration ROM mapping register**

Bit	31	30	29	28	27	26	25	24	23	22	21	20	19	18	17	16
Name	Configuration ROM mapping															
Type	R/W	R/W	R/W	R/W	R/W	R/W	R/W	R/W	R/W	R/W	R/W	R/W	R/W	R/W	R/W	R/W
Default	0	0	0	0	0	0	0	0	0	0	0	0	0	0	0	0
Bit	15	14	13	12	11	10	9	8	7	6	5	4	3	2	1	0
Name	Configuration ROM mapping															
Type	R/W	R/W	R/W	R/W	R/W	R/W	R	R	R	R	R	R	R	R	R	R
Default	0	0	0	0	0	0	0	0	0	0	0	0	0	0	0	0

Register: **Configuration ROM mapping**  
 Type: Read-only, Read/Write  
 Offset: 34h  
 Default: 0000 0000h  
 Description: This register contains the start address within system memory that will map to the start address of 1394 configuration ROM for this node.

**Table 103. Configuration ROM Mapping Register Description**

BIT	FIELD NAME	TYPE	DESCRIPTION
31–10	configROMAddr	R/W	If a quadlet read request to 1394 offset 48'hFFFF_F000_0400 through offset 48'hFFFF_F000_07FF is received, then the low order 10 bits of the offset are added to this register to determine the host memory address of the read request.
9–0	RSVD	R	Reserved. These bits return 0s when read.

**posted write address low register**

Bit	31	30	29	28	27	26	25	24	23	22	21	20	19	18	17	16
Name	Posted write address low															
Type	RU	RU	RU	RU	RU	RU	RU	RU	RU	RU	RU	RU	RU	RU	RU	RU
Default	X	X	X	X	X	X	X	X	X	X	X	X	X	X	X	X
Bit	15	14	13	12	11	10	9	8	7	6	5	4	3	2	1	0
Name	Posted write address low															
Type	RU	RU	RU	RU	RU	RU	RU	RU	RU	RU	RU	RU	RU	RU	RU	RU
Default	X	X	X	X	X	X	X	X	X	X	X	X	X	X	X	X

Register: **Posted write address low**  
 Type: Read/Update  
 Offset: 38h  
 Default: XXXX XXXXh  
 Description: This register is used to communicate error information if a write request is posted and an error occurs while writing the posted data packet.

**Table 104. Posted Write Address Low Register Description**

BIT	FIELD NAME	TYPE	DESCRIPTION
31–0	offsetLo	RU	The lower 32 bits of the 1394 destination offset of the write request that failed.

# PCI4450 GFN/GJG PC Card and OHCI Controller

SCPS046 – JANUARY 1999

## posted write address high register

Bit	31	30	29	28	27	26	25	24	23	22	21	20	19	18	17	16
Name	Posted write address high															
Type	RU	RU	RU	RU	RU	RU	RU	RU	RU	RU	RU	RU	RU	RU	RU	RU
Default	X	X	X	X	X	X	X	X	X	X	X	X	X	X	X	X
Bit	15	14	13	12	11	10	9	8	7	6	5	4	3	2	1	0
Name	Posted write address high															
Type	RU	RU	RU	RU	RU	RU	RU	RU	RU	RU	RU	RU	RU	RU	RU	RU
Default	X	X	X	X	X	X	X	X	X	X	X	X	X	X	X	X

Register: **Posted write address high**  
 Type: Read/Update  
 Offset: 3Ch  
 Default: XXXX XXXXh  
 Description: This register is used to communicate error information if a write request is posted and an error occurs while writing the posted data packet.

**Table 105. Posted Write Address High Register Description**

BIT	FIELD NAME	TYPE	DESCRIPTION
31–16	sourceID	RU	This bus and node number of the node that issued the write request that failed.
15–0	offsetHi	RU	The upper 16 bits of the 1394 destination offset of the write request that failed.

## vendor ID register

Bit	31	30	29	28	27	26	25	24	23	22	21	20	19	18	17	16
Name	Vendor ID															
Type	R	R	R	R	R	R	R	R	R	R	R	R	R	R	R	R
Default	0	0	0	0	0	0	0	0	0	0	0	0	0	0	0	0
Bit	15	14	13	12	11	10	9	8	7	6	5	4	3	2	1	0
Name	Vendor ID															
Type	R	R	R	R	R	R	R	R	R	R	R	R	R	R	R	R
Default	0	0	0	0	0	0	0	0	0	0	0	0	0	0	0	0

Register: **Vendor ID**  
 Type: Read-only  
 Offset: 40h  
 Default: 0000 0000h  
 Description: The vendor ID register holds the company ID of an organization that specifies any vendor-unique registers. The PCI4450 does not implement Texas Instruments unique behavior with regards to Open HCI. Thus this register is read-only and returns 0s when read.





host controller control register

Bit	31	30	29	28	27	26	25	24	23	22	21	20	19	18	17	16
Name	Host controller control															
Type	RSC	R	R	R	R	R	R	R	RC	RSC	R	R	RSC	RSC	RSC	RSCU
Default	0	X	0	0	0	0	0	0	0	0	0	0	0	X	0	0
Bit	15	14	13	12	11	10	9	8	7	6	5	4	3	2	1	0
Name	Host controller control															
Type	R	R	R	R	R	R	R	R	R	R	R	R	R	R	R	R
Default	0	0	0	0	0	0	0	0	0	0	0	0	0	0	0	0

Register: **Host controller control**  
 Type: Read/Set/Clear/Update  
 Offset: 50h set register  
 54h clear register  
 Default: X00X 0000h  
 Description: This set/clear register pair provides flags for controlling the PCI4450 link function.

Table 106. Host Controller Control Register Description

BIT	FIELD NAME	TYPE	DESCRIPTION
31	RSVD	R	Reserved. These bits return 0s when read.
30	noByteSwapData	RSC	This bit is used to control whether physical accesses to locations outside the PCI4450 itself as well as any other DMA data accesses should be swapped.
29–24	RSVD	R	Reserved. These bits return 0s when read.
23	programPhyEnable	RC	This bit informs upper level software that lower level software has consistently configured the p1394a enhancements in the Link and PHY. When 1 generic software such as the OHCI driver is responsible for configuring p1394a enhancements in the PHY and the aPhyEnhanceEnable bit in the PCI4450. When 0, the generic software may not modify the p1394a enhancements in the PCI4450 or PHY and cannot interpret the setting of aPhyEnhanceEnable. This bit can be initialized from serial EEPROM.
22	aPhyEnhanceEnable	RSC	When the programPhyenable is 1 and link enable is 1, the OHCI driver can set this bit to use all p1394a enhancements. When programPhyEnable is set 0, the software shall not change PHY enhancements or the aPhyEnhanceEnable bit.
21–20	RSVD	R	Reserved. These bits return 0s when read.
19	LPS	RSC	This bit is used to control the link power status. Software must set LPS to 1 to permit the link-PHY communication. A 0 prevents link-PHY communication.
18	postedWriteEnable	RSC	This bit is used to enable (1) or disable (0) posted writes. Software should change this bit only when linkEnable is 0.
17	linkEnable	RSC	This bit is cleared to 0 by a hardware reset or software reset. Software must set this bit to 1 when the system is ready to begin operation and then force a bus reset. This bit is necessary to keep other nodes from sending transactions before the local system is ready. When this bit is clear the PCI4450 is logically and immediately disconnected from the 1394 bus, no packets will be received or processed nor will packets be transmitted.
16	SoftReset	RSCU	When set to 1, all PCI4450 state is reset, all FIFO's are flushed, and all OHCI registers are set to their hardware reset values unless otherwise specified. PCI registers are not affected by this bit. This bit remains set to 1 while the softReset is in progress and reverts back to 0 when the reset has completed.
15–0	RSVD	R	Reserved. These bits return 0s when read.

# PCI4450 GFN/GJG PC Card and OHCI Controller

SCPS046 – JANUARY 1999

## self ID buffer pointer register

Bit	31	30	29	28	27	26	25	24	23	22	21	20	19	18	17	16
Name	Self ID buffer pointer															
Type	R/W	R/W	R/W	R/W	R/W	R/W	R/W	R/W	R/W	R/W	R/W	R/W	R/W	R/W	R/W	R/W
Default	0	0	0	0	0	0	0	0	0	0	0	0	0	0	0	0
Bit	15	14	13	12	11	10	9	8	7	6	5	4	3	2	1	0
Name	Self ID buffer pointer															
Type	R/W	R/W	R/W	R/W	R/W	R	R	R	R	R	R	R	R	R	R	R
Default	0	0	0	0	0	0	0	0	0	0	0	0	0	0	0	0

Register: **Self ID buffer pointer**  
 Type: Read-only, Read/Write  
 Offset: 64h  
 Default: XXXX XX00h  
 Description: This register points to the 2-Kbyte aligned base address of the buffer in host memory where the self ID packets will be stored during bus initialization. Bits 31–11 are read/write accessible.

## self ID count register

Bit	31	30	29	28	27	26	25	24	23	22	21	20	19	18	17	16
Name	Self ID count															
Type	RU	R	R	R	R	R	R	R	RU	RU	RU	RU	RU	RU	RU	RU
Default	X	0	0	0	0	0	0	0	X	X	X	X	X	X	X	X
Bit	15	14	13	12	11	10	9	8	7	6	5	4	3	2	1	0
Name	Self ID count															
Type	R	R	R	R	R	RU	RU	RU	RU	RU	RU	RU	RU	RU	R	R
Default	0	0	0	0	0	0	0	0	0	0	0	0	0	0	0	0

Register: **Self ID count**  
 Type: Read/Update  
 Offset: 68h  
 Default: X0XX 0000h  
 Description: This register keeps a count of the number of times the bus self ID process has occurred, flags self ID packet errors, and keeps a count of the amount of self ID data in the self ID buffer.

**Table 107. Self ID Count Register Description**

BIT	FIELD NAME	TYPE	DESCRIPTION
31	selfIDError	RU	When this bit is 1, an error was detected during the most recent self ID packet reception. The contents of the self ID buffer are undefined. This bit is cleared after a self ID reception in which no errors are detected. Note that an error can be a hardware error or a host bus write error.
30–24	RSVD	R	Reserved. These bits return 0s when read.
23–16	selfIDGeneration	RU	The value in this field increments each time a bus reset is detected. This field rolls over to 0 after reaching 255.
15–11	RSVD	R	Reserved. These bits return 0s when read.
10–2	selfIDSize	RU	This field indicates the number of quadlets that have been written into the self ID buffer for the current selfIDGeneration. This includes the header quadlet and the self ID data. This field is cleared to 0 when the self ID reception begins.
1–0	RSVD	R	Reserved. These bits return 0s when read.



**ISO receive channel mask high register**

<b>Bit</b>	<b>31</b>	<b>30</b>	<b>29</b>	<b>28</b>	<b>27</b>	<b>26</b>	<b>25</b>	<b>24</b>	<b>23</b>	<b>22</b>	<b>21</b>	<b>20</b>	<b>19</b>	<b>18</b>	<b>17</b>	<b>16</b>
<b>Name</b>	ISO receive channel mask high															
<b>Type</b>	RSC	RSC	RSC	RSC	RSC	RSC	RSC	RSC	RSC	RSC	RSC	RSC	RSC	RSC	RSC	RSC
<b>Default</b>	X	X	X	X	X	X	X	X	X	X	X	X	X	X	X	X
<b>Bit</b>	<b>15</b>	<b>14</b>	<b>13</b>	<b>12</b>	<b>11</b>	<b>10</b>	<b>9</b>	<b>8</b>	<b>7</b>	<b>6</b>	<b>5</b>	<b>4</b>	<b>3</b>	<b>2</b>	<b>1</b>	<b>0</b>
<b>Name</b>	ISO receive channel mask high															
<b>Type</b>	RSC	RSC	RSC	RSC	RSC	RSC	RSC	RSC	RSC	RSC	RSC	RSC	RSC	RSC	RSC	RSC
<b>Default</b>	X	X	X	X	X	X	X	X	X	X	X	X	X	X	X	X

Register: **ISO receive channel mask high**

Type: Read/Set/Clear

Offset: 70h set register  
74h clear register

Default: XXXX XXXXh

Description: This set/clear register is used to enable packet receives from the upper 32 isochronous data channels. A read from either the set register or clear register returns the value of the IRChannelMaskHi register.

**Table 108. ISO Receive Channel Mask High Register Description**

<b>BIT</b>	<b>FIELD NAME</b>	<b>TYPE</b>	<b>DESCRIPTION</b>
31	isoChannel63	RSC	When set, the PCI4450 is enabled to receive from iso channel number 63.
30	isoChannel62	RSC	When set, the PCI4450 is enabled to receive from iso channel number 62.
29	isoChannel61	RSC	When set, the PCI4450 is enabled to receive from iso channel number 61.
28	isoChannel60	RSC	When set, the PCI4450 is enabled to receive from iso channel number 60.
27	isoChannel59	RSC	When set, the PCI4450 is enabled to receive from iso channel number 59.
26	isoChannel58	RSC	When set, the PCI4450 is enabled to receive from iso channel number 58.
25	isoChannel57	RSC	When set, the PCI4450 is enabled to receive from iso channel number 57.
24	isoChannel56	RSC	When set, the PCI4450 is enabled to receive from iso channel number 56.
23	isoChannel55	RSC	When set, the PCI4450 is enabled to receive from iso channel number 55.
22	isoChannel54	RSC	When set, the PCI4450 is enabled to receive from iso channel number 54.
21	isoChannel53	RSC	When set, the PCI4450 is enabled to receive from iso channel number 53.
20	isoChannel52	RSC	When set, the PCI4450 is enabled to receive from iso channel number 52.
19	isoChannel51	RSC	When set, the PCI4450 is enabled to receive from iso channel number 51.
18	isoChannel50	RSC	When set, the PCI4450 is enabled to receive from iso channel number 50.
17	isoChannel49	RSC	When set, the PCI4450 is enabled to receive from iso channel number 49.
16	isoChannel48	RSC	When set, the PCI4450 is enabled to receive from iso channel number 48.
15	isoChannel47	RSC	When set, the PCI4450 is enabled to receive from iso channel number 47.
14	isoChannel46	RSC	When set, the PCI4450 is enabled to receive from iso channel number 46.
13	isoChannel45	RSC	When set, the PCI4450 is enabled to receive from iso channel number 45.
12	isoChannel44	RSC	When set, the PCI4450 is enabled to receive from iso channel number 44.
11	isoChannel43	RSC	When set, the PCI4450 is enabled to receive from iso channel number 43.
10	isoChannel42	RSC	When set, the PCI4450 is enabled to receive from iso channel number 42.
9	isoChannel41	RSC	When set, the PCI4450 is enabled to receive from iso channel number 41.
8	isoChannel40	RSC	When set, the PCI4450 is enabled to receive from iso channel number 40.

**Table 108. ISO Receive Channel Mask High Register Description (Continued)**

BIT	FIELD NAME	TYPE	DESCRIPTION
7	isoChannel39	RSC	When set, the PCI4450 is enabled to receive from iso channel number 39.
6	isoChannel38	RSC	When set, the PCI4450 is enabled to receive from iso channel number 38.
5	isoChannel37	RSC	When set, the PCI4450 is enabled to receive from iso channel number 37.
4	isoChannel36	RSC	When set, the PCI4450 is enabled to receive from iso channel number 36.
3	isoChannel35	RSC	When set, the PCI4450 is enabled to receive from iso channel number 35.
2	isoChannel34	RSC	When set, the PCI4450 is enabled to receive from iso channel number 34.
1	isoChannel33	RSC	When set, the PCI4450 is enabled to receive from iso channel number 33.
0	isoChannel32	RSC	When set, the PCI4450 is enabled to receive from iso channel number 32.

**ISO receive channel mask low register**

Bit	31	30	29	28	27	26	25	24	23	22	21	20	19	18	17	16
<b>Name</b>	ISO receive channel mask low															
<b>Type</b>	RSC	RSC	RSC	RSC	RSC	RSC	RSC	RSC	RSC	RSC	RSC	RSC	RSC	RSC	RSC	RSC
<b>Default</b>	X	X	X	X	X	X	X	X	X	X	X	X	X	X	X	X
Bit	15	14	13	12	11	10	9	8	7	6	5	4	3	2	1	0
<b>Name</b>	ISO receive channel mask low															
<b>Type</b>	RSC	RSC	RSC	RSC	RSC	RSC	RSC	RSC	RSC	RSC	RSC	RSC	RSC	RSC	RSC	RSC
<b>Default</b>	X	X	X	X	X	X	X	X	X	X	X	X	X	X	X	X

Register: **ISO receive channel mask low**

Type: Read/Set/Clear

Offset: 78h set register  
7Ch clear register

Default: XXXX XXXXh

Description: This set/clear register is used to enable packet receives from the lower 32 isochronous data channels.

**Table 109. ISO Receive Channel Mask Low Register Descriptions**

BIT	FIELD NAME	TYPE	DESCRIPTION
31	isoChannel31	RSC	When set, the PCI4450 is enabled to receive from iso channel number 31.
30	isoChannel30	RSC	When set, the PCI4450 is enabled to receive from iso channel number 30.
:	:	:	Bits 29 through 2 follow the same pattern
1	isoChannel1	RSC	When set, the PCI4450 is enabled to receive from iso channel number 1.
0	isoChannel0	RSC	When set, the PCI4450 is enabled to receive from iso channel number 0.



interrupt event register

Bit	31	30	29	28	27	26	25	24	23	22	21	20	19	18	17	16
Name	Interrupt event															
Type	R	R	R	R	R	RSCU	RSCU	RSCU	RSCU	RSCU	RSCU	RSCU	RSCU	R	RSCU	RSCU
Default	0	X	0	0	0	X	X	X	X	X	X	X	X	0	X	X
Bit	15	14	13	12	11	10	9	8	7	6	5	4	3	2	1	0
Name	Interrupt event															
Type	R	R	R	R	R	R	RSCU	RSCU	RU	RU	RSCU	RSCU	RSCU	RSCU	RSCU	RSCU
Default	0	0	0	0	0	0	X	X	X	X	X	X	X	X	X	X

Register: **Interrupt event**  
 Type: Read/Set/Clear/Update  
 Offset: 80h set register  
 84h clear register [returns IntEvent and IntMask when read]  
 Default: XXXX 0XXXh  
 Description: This set/clear register reflects the state of the various PCI4450 interrupt sources. The interrupt bits are set by an asserting edge of the corresponding interrupt signal, or by writing a 1 in the corresponding bit in the set register. The only mechanism to clear the bits in this register is to write a 1 to the corresponding bit in the clear register.

Table 110. Interrupt Event Register Description

BIT	FIELD NAME	TYPE	DESCRIPTION
31	RSVD	R	Reserved. This bit returns 0 when read.
30	vendorSpecific	R	Vendor defined.
29–27	RSVD	R	Reserved. These bits return 0s when read.
26	phyRegRcvd	RSCU	The PCI4450 has received a PHY register data byte which can be read from the PHY control register.
25	cycleTooLong	RSCU	If LinkControl.cycleMaster is set, this indicated that over 125 μs elapsed between the start of sending a cycle start packet and the end of a subaction gap. LinkControl.cycleMaster is cleared by this event.
24	unrecoverableError	RSCU	This event occurs when the PCI4450 encounters any error that forces it to stop operations on any or all of its subunits. For example, when a DMA context sets its dead bit. While unrecoverableError is set, all normal interrupts for the context(s) that caused this interrupt will be blocked from being set.
23	cycleInconsistent	RSCU	A cycle start was received that had an isochronous cycleTimer.seconds and isochronous cycleTimer.count different from the value in the CycleTimer register.
22	cycleLost	RSCU	A lost cycle is indicated when no cycle_start packet is sent/received between two successive cycleSynch events. A lost cycle can be predicted when a cycle_start packet does not immediately follow the first subaction gap after the cycleSynch event or if an arbitration reset gap is detected after a cycleSynch event without an intervening cycle start. CycleLost may be set either when it occurs or when logic predicts that it will occur.
21	cycle64Seconds	RSCU	Indicates that the 7 <sup>th</sup> bit of the cycle second counter has changed.
20	cycleSynch	RSCU	Indicates that a new isochronous cycle has started and is set when the low order bit of the cycle count toggles.
19	phy	RSCU	Indicates the PHY requests an interrupt through a status transfer.
18	RSVD	R	Reserved. These bits return 0s when read.
17	busReset	RSCU	Indicates that the PHY chip has entered bus reset mode.

# PCI4450 GFN/GJG PC Card and OHCI Controller

SCPS046 – JANUARY 1999

**Table 110. Interrupt Event Register Description (Continued)**

BIT	FIELD NAME	TYPE	DESCRIPTION
16	selfDcomplete	RSCU	A selfID packet stream has been received. It will be generated at the end of the bus initialization process. This bit is turned off simultaneously when IntEvent.busReset is turned on.
15–10	RSVD	R	Reserved. These bits return 0s when read.
9	lockRespErr	RSCU	Indicates that the PCI4450 sent a lock response for a lock request to a serial bus register, but did not receive an ack_complete.
8	postedWriteErr	RSCU	Indicates that a host bus error occurred while the PCI4450 was trying to write a 1394 write request, which had already been given an ack_complete, into system memory.
7	isochRx	RU	Isochronous receive DMA interrupt. Indicates that one or more isochronous receive contexts have generated and interrupt. This is not a latched event, it is the OR'ing of all bits in (isoRecvIntEvent and isoRecvIntMask). The isoRecvIntEvent register indicates which contexts have interrupted.
6	isochTx	RU	Isochronous transmit DMA interrupt. Indicates that one or more isochronous transmit contexts have generated and interrupt. This is not a latched event, it is the OR'ing of all bits in (isoXmitIntEvent and isoXmitIntMask). The isoXmitIntEvent register indicates which contexts have interrupted.
5	RSPkt	RSCU	Indicates that a packet was sent to an asynchronous receive response context buffer and the descriptor's xferStatus and resCount fields have been updated.
4	RQPkt	RSCU	Indicates that a packet was sent to an asynchronous receive request context buffer and the descriptor's xferStatus and resCount fields have been updated.
3	ARRS	RSCU	Async receive response DMA interrupt. This bit is conditionally set upon completion of an ARRS context command descriptor.
2	ARRQ	RSCU	Async receive request DMA interrupt. This bit is conditionally set upon completion of an ARRQ DMA context command descriptor.
1	respTxComplete	RSCU	Asynchronous response transmit DMA interrupt. This bit is conditionally set upon completion of an ATRS DMA command.
0	reqTxComplete	RSCU	Asynchronous request transmit DMA interrupt. This bit is conditionally set upon completion of an ATRQ DMA command.



**interrupt mask register**

<b>Bit</b>	31	30	29	28	27	26	25	24	23	22	21	20	19	18	17	16
<b>Name</b>	Interrupt mask															
<b>Type</b>	RSC	R	R	R	R	RSCU	RSCU	RSCU	RSCU	RSCU	RSCU	RSCU	RSCU	R	RSCU	RSCU
<b>Default</b>	0	X	0	0	0	X	X	X	X	X	X	X	X	0	X	X
<b>Bit</b>	15	14	13	12	11	10	9	8	7	6	5	4	3	2	1	0
<b>Name</b>	Interrupt mask															
<b>Type</b>	R	R	R	R	R	R	RSCU	RSCU	RU	RU	RSCU	RSCU	RSCU	RSCU	RSCU	RSCU
<b>Default</b>	0	0	0	0	0	0	X	X	X	X	X	X	X	X	X	X

Register: **Interrupt mask**  
 Type: Read/Set/Clear  
 Offset: 88h set register  
 8Ch clear register  
 Default: XXXX 0XXXh  
 Description: This set/clear register is used to enable the various PCI4450 interrupt sources. Reads from either the set register or the clear register always return IntMask. In all cases except masterIntEnable (bit 31), the enables for each interrupt event align with the event register bits detailed in Table 110.

**Table 111. Interrupt Mask Register Description**

BIT	FIELD NAME	TYPE	DESCRIPTION
31	masterIntEnable	RSC	When set, external interrupts will be generated in accordance with the IntMask register. If clear, no external interrupts will be generated.
30–0			See Table 110

# PCI4450 GFN/GJG PC Card and OHCI Controller

SCPS046 – JANUARY 1999

## isochronous transmit interrupt event register

Bit	31	30	29	28	27	26	25	24	23	22	21	20	19	18	17	16
Name	Isochronous transmit interrupt event															
Type	R	R	R	R	R	R	R	R	R	R	R	R	R	R	R	R
Default	0	0	0	0	0	0	0	0	0	0	0	0	0	0	0	0
Bit	15	14	13	12	11	10	9	8	7	6	5	4	3	2	1	0
Name	Isochronous transmit interrupt event															
Type	R	R	R	R	R	R	R	R	RSC	RSC	RSC	RSC	RSC	RSC	RSC	RSC
Default	0	0	0	0	0	0	0	0	X	X	X	X	X	X	X	X

Register: **Isochronous transmit interrupt event**  
 Type: Read/Set/Clear  
 Offset: 90h set register  
 84h clear register [returns IsoXmitEvent and IsoXmitMask when read]  
 Default: 0000 00XXh  
 Description: This set/clear register reflects the interrupt state of the isochronous transmit contexts. An interrupt is generated on behalf of an isochronous transmit context if an OUTPUT\_LAST command completes and its interrupt bits are set. Upon determining that the IntEvent.isoTx interrupt has occurred, software can check this register to determine which context(s) caused the interrupt. The interrupt bits are set by an asserting edge of the corresponding interrupt signal, or by writing a 1 in the corresponding bit in the set register. The only mechanism to clear the bits in this register is to write a 1 to the corresponding bit in the clear register.

**Table 112. Isochronous Transmit Interrupt Event Register Description**

BIT	FIELD NAME	TYPE	DESCRIPTION
31–8	RSVD	R	Reserved. These bits return 0s when read.
7	isoXmit7	RSC	Isochronous transmit channel 7 caused the isoTx interrupt.
6	isoXmit6	RSC	Isochronous transmit channel 6 caused the isoTx interrupt.
5	isoXmit5	RSC	Isochronous transmit channel 5 caused the isoTx interrupt.
4	isoXmit4	RSC	Isochronous transmit channel 4 caused the isoTx interrupt.
3	isoXmit3	RSC	Isochronous transmit channel 3 caused the isoTx interrupt.
2	isoXmit2	RSC	Isochronous transmit channel 2 caused the isoTx interrupt.
1	isoXmit1	RSC	Isochronous transmit channel 1 caused the isoTx interrupt.
0	isoXmit0	RSC	Isochronous transmit channel 0 caused the isoTx interrupt.





**isochronous transmit interrupt mask register**

<b>Bit</b>	<b>31</b>	<b>30</b>	<b>29</b>	<b>28</b>	<b>27</b>	<b>26</b>	<b>25</b>	<b>24</b>	<b>23</b>	<b>22</b>	<b>21</b>	<b>20</b>	<b>19</b>	<b>18</b>	<b>17</b>	<b>16</b>
<b>Name</b>	Isochronous transmit interrupt mask															
<b>Type</b>	R	R	R	R	R	R	R	R	R	R	R	R	R	R	R	R
<b>Default</b>	0	0	0	0	0	0	0	0	0	0	0	0	0	0	0	0
<b>Bit</b>	<b>15</b>	<b>14</b>	<b>13</b>	<b>12</b>	<b>11</b>	<b>10</b>	<b>9</b>	<b>8</b>	<b>7</b>	<b>6</b>	<b>5</b>	<b>4</b>	<b>3</b>	<b>2</b>	<b>1</b>	<b>0</b>
<b>Name</b>	Isochronous transmit interrupt mask															
<b>Type</b>	R	R	R	R	R	R	R	R	R	R	R	R	R	R	R	R
<b>Default</b>	0	0	0	0	0	0	0	0	X	X	X	X	X	X	X	X

Register: **Isochronous transmit interrupt mask**

Type: Read/Set/Clear

Offset: 98h set register  
9Ch clear register

Default: 0000 00XXh

Description: This set/clear register is used to enable the isochTx interrupt source on a per channel basis. Reads from either the set register or the clear register always return IsoXmitIntMask. In all cases the enables for each interrupt event align with the event register bits detailed in Table 112.

# PCI4450 GFN/GJG PC Card and OHCI Controller

SCPS046 – JANUARY 1999

## isochronous receive interrupt event register

Bit	31	30	29	28	27	26	25	24	23	22	21	20	19	18	17	16
Name	Isochronous receive interrupt event															
Type	R	R	R	R	R	R	R	R	R	R	R	R	R	R	R	R
Default	0	0	0	0	0	0	0	0	0	0	0	0	0	0	0	0
Bit	15	14	13	12	11	10	9	8	7	6	5	4	3	2	1	0
Name	Isochronous receive interrupt event															
Type	R	R	R	R	R	R	R	R	R	R	R	R	RSC	RSC	RSC	RSC
Default	0	0	0	0	0	0	0	0	0	0	0	0	X	X	X	X

Register: **Isochronous receive interrupt event**

Type: Read/Set/Clear

Offset: A0h set register

A4h clear register [returns IsoRecvEvent and IsoRecvMask when read]

Default: 0000 000Xh

Description: This set/clear register reflects the interrupt state of the isochronous receive contexts. An interrupt is generated on behalf of an isochronous receive context if an INPUT\_\* command completes and its interrupt bits are set. Upon determining that the IntEvent.isoChRx interrupt has occurred, software can check this register to determine which context(s) caused the interrupt. The interrupt bits are set by an asserting edge of the corresponding interrupt signal, or by writing a 1 in the corresponding bit in the set register. The only mechanism to clear the bits in this register is to write a 1 to the corresponding bit in the clear register.

**Table 113. Isochronous Receive Interrupt Event Register Description**

BIT	FIELD NAME	TYPE	DESCRIPTION
31–4	RSVD	R	Reserved. These bits return 0s when read.
3	isoRecv3	RSC	Isochronous receive channel 3 caused the isoChRx interrupt.
2	isoRecv2	RSC	Isochronous receive channel 2 caused the isoChRx interrupt.
1	isoRecv1	RSC	Isochronous receive channel 1 caused the isoChRx interrupt.
0	isoRecv0	RSC	Isochronous receive channel 0 caused the isoChRx interrupt.



**isochronous receive interrupt mask register**

Bit	31	30	29	28	27	26	25	24	23	22	21	20	19	18	17	16
Name	Isochronous receive interrupt mask															
Type	R	R	R	R	R	R	R	R	R	R	R	R	R	R	R	R
Default	0	0	0	0	0	0	0	0	0	0	0	0	0	0	0	0
Bit	15	14	13	12	11	10	9	8	7	6	5	4	3	2	1	0
Name	Isochronous receive interrupt mask															
Type	R	R	R	R	R	R	R	R	R	R	R	R	R	R	R	R
Default	0	0	0	0	0	0	0	0	0	0	0	0	X	X	X	X

Register: **Isochronous receive interrupt mask**

Type: Read/Set/Clear

Offset: A8h set register  
ACh clear register

Default: 0000 000Xh

Description: This set/clear register is used to enable the isochRx interrupt source on a per channel basis. Reads from either the set register or the clear register always return IsoRecvIntMask. In all cases the enables for each interrupt event align with the event register bits detailed in Table 113.

**fairness control register (optional register)**

Bit	31	30	29	28	27	26	25	24	23	22	21	20	19	18	17	16
Name	Fairness control															
Type	R	R	R	R	R	R	R	R	R	R	R	R	R	R	R	R
Default	X	X	X	X	X	X	X	X	X	X	X	X	X	X	X	X
Bit	15	14	13	12	11	10	9	8	7	6	5	4	3	2	1	0
Name	Fairness control															
Type	R	R	R	R	R	R	R	R	R	R	R	R	R	R	R	R
Default	X	X	X	X	X	X	X	X	0	0	0	0	0	0	0	0

Register: **Fairness control**

Type: Read-only

Offset: DCh

Default: XXXX XX00h

Description: This register provides a mechanism by which software can direct the host controller to transmit multiple asynchronous requests during a fairness interval.

**Table 114. Link Control Register Description**

BIT	FIELD NAME	TYPE	DESCRIPTION
31–8	RSVD	R	Reserved.
7–0	pri_req	R	This field specifies the maximum number of priority arbitration requests for asynchronous request packets that the link is permitted to make of the PHY during fairness interval.

# PCI4450 GFN/GJG PC Card and OHCI Controller

SCPS046 – JANUARY 1999

## link control register

Bit	31	30	29	28	27	26	25	24	23	22	21	20	19	18	17	16
<b>Name</b>	Link control															
<b>Type</b>	R	R	R	R	R	R	R	R	R	RSC	RSCU	RSC	R	R	R	R
<b>Default</b>	0	0	0	0	0	0	0	0	0	X	X	X	0	0	0	0
Bit	15	14	13	12	11	10	9	8	7	6	5	4	3	2	1	0
<b>Name</b>	Link control															
<b>Type</b>	R	R	R	R	R	RSC	RSC	R	R	R	R	R	R	R	R	R
<b>Default</b>	0	0	0	0	0	X	X	0	0	0	0	0	0	0	0	0

Register: **Link control**

Type: Read/Set/Clear/Update

Offset: E0h set register

E4h clear register

Default: 00X0 0X00h

Description: This set/clear register provides the control flags that enable and configure the link core protocol portions of the PCI4450. It contains controls for the receiver and cycle timer.

**Table 115. Link Control Register Description**

BIT	FIELD NAME	TYPE	DESCRIPTION
31–23	RSVD	R	Reserved. These bits return 0s when read.
22	cycleSource	RSC	When 1, the cycle timer will use an external source (CYCLEIN) to determine when to roll over the cycle timer. When 0, the cycle timer rolls over when the timer reaches 3072 cycles of the 24.576 MHz clock (125 μs).
21	cycleMaster	RSCU	When set, and the PHY has notified the PCI4450 that it is root, the PCI4450 will generate a cycle start packet every time the cycle timer rolls over, based on the setting of the cycleSource bit. When 0, the OHICLynx will accept received cycle start packets to maintain synchronization with the node which is sending them. This bit is automatically reset when the cycleTooLong event occurs and cannot be set until the IntEvent.cycleTooLong bit is cleared.
20	CycleTimerEnable	RSC	When 1, the cycle timer offset will count cycles of the 24.576 MHz clock and roll over at the appropriate time based on the settings of the above bits. When 0, the cycle timer offset will not count.
19–11	RSVD	R	Reserved. These bits return 0s when read.
10	RcvPhyPkt	RSC	When 1, the receiver will accept incoming PHY packets into the AR request context if the AR request context is enabled. This does not control receipt of self-identification packets.
9	RcvSelfID	RSC	When 1, the receiver will accept incoming self-identification packets. Before setting this bit to 1, software must ensure that the self ID buffer pointer register contains a valid address.
8–0	RSVD	R	Reserved. These bits return 0s when read.



**node identification register**

<b>Bit</b>	31	30	29	28	27	26	25	24	23	22	21	20	19	18	17	16
<b>Name</b>	Node identification															
<b>Type</b>	RU	RU	R	R	RU	R	R	R	R	R	R	R	R	R	R	R
<b>Default</b>	0	0	0	0	0	0	0	0	0	0	0	0	0	0	0	0
<b>Bit</b>	15	14	13	12	11	10	9	8	7	6	5	4	3	2	1	0
<b>Name</b>	Node identification															
<b>Type</b>	RWU	RWU	RWU	RWU	RWU	RWU	RWU	RWU	RWU	RWU	RU	RU	RU	RU	RU	RU
<b>Default</b>	1	1	1	1	1	1	1	1	1	1	X	X	X	X	X	X

Register: **Node identification**

Type: Read/Write/Update

Offset: E8h

Default: 0000 11XXh

Description: This register contains the address of the node on which the OHICLynx chip resides, and indicates the valid node number status. The 16-bit combination of busNumber and NodeNumber is referred to as the node ID.

**Table 116. Node Identification Register Description**

BIT	FIELD NAME	TYPE	DESCRIPTION
31	iDValid	RU	This bit indicates whether or not the PCI4450 has a valid node number. It is cleared when a 1394 bus reset is detected and set when the PCI4450 receives a new node number from the PHY.
30	root	RU	This bit is set during the bus reset process if the attached PHY is root.
29–28	RSVD	R	Reserved. These bits return 0s when read.
27	CPS	RU	Set if the PHY is reporting that cable power status is OK (VP 8V).
26–16	RSVD	R	Reserved. These bits return 0s when read.
15–6	busNumber	RWU	This number is used to identify the specific 1394 bus the PCI4450 belongs to when multiple 1394-compatible buses are connected via a bridge.
5–0	NodeNumber	RU	This number is the physical node number established by the PHY during self-identification. It is automatically set to the value received from the PHY after the self-identification phase. If the PHY sets the nodeNumber to 63, software should not set ContextControl.run for either of the AT DMA contexts.

# PCI4450 GFN/GJG PC Card and OHCI Controller

SCPS046 – JANUARY 1999

## PHY control register

Bit	31	30	29	28	27	26	25	24	23	22	21	20	19	18	17	16
Name	PHY control															
Type	RU	R	R	R	RU	RU	RU	RU	RU	RU	RU	RU	RU	RU	RU	RU
Default	X	0	0	0	X	X	X	X	X	X	X	X	X	X	X	X
Bit	15	14	13	12	11	10	9	8	7	6	5	4	3	2	1	0
Name	PHY control															
Type	RWU	RWU	R	R	R/W	R/W	R/W	R/W	R/W	R/W	R/W	R/W	R/W	R/W	R/W	R/W
Default	0	0	0	0	X	X	X	X	X	X	X	X	X	X	X	X

Register: **PHY control**  
 Type: Read/Write/Update  
 Offset: ECh  
 Default: XXXX 0XXXh  
 Description: This register is used to read or write a PHY register.

**Table 117. PHY Control Register Description**

BIT	FIELD NAME	TYPE	DESCRIPTION
31	rdDone	RU	This bit is cleared to 0 by the PCI4450 when either rdReg or wrReg is set to 1. This bit is set to 1 when a register transfer is received from the PHY.
30–28	RSVD	R	Reserved. These bits return 0s when read.
27–24	rdAddr	RU	This is the address of the register most recently received from the PHY.
23–16	rdData	RU	This field is the contents of a PHY register which has been read.
15	rdReg	RWU	This bit is set by software to initiate a read request to a PHY register, and is cleared by hardware when the request has been sent. The wrReg and rdReg bits must be used exclusively.
14	wrReg	RWU	This bit is set by software to initiate a write request to a PHY register, and is cleared by hardware when the request has been sent. The wrReg and rdReg bits must be used exclusively.
13–12	RSVD	R	Reserved. These bits return 0s when read.
11–8	regAddr	R/W	This field is the address of the PHY register to be written or read.
7–0	wrData	R/W	This field is the data to be written to a PHY register, and is ignored for reads.



**isochronous cycle timer register**

<b>Bit</b>	31	30	29	28	27	26	25	24	23	22	21	20	19	18	17	16
<b>Name</b>	Isochronous cycle timer															
<b>Type</b>	RWU	RWU	RWU	RWU	RWU	RWU	RWU	RWU	RWU	RWU	RWU	RWU	RWU	RWU	RWU	RWU
<b>Default</b>	X	X	X	X	X	X	X	X	X	X	X	X	X	X	X	X
<b>Bit</b>	15	14	13	12	11	10	9	8	7	6	5	4	3	2	1	0
<b>Name</b>	Isochronous cycle timer															
<b>Type</b>	RWU	RWU	RWU	RWU	RWU	RWU	RWU	RWU	RWU	RWU	RWU	RWU	RWU	RWU	RWU	RWU
<b>Default</b>	X	X	X	X	X	X	X	X	X	X	X	X	X	X	X	X

Register: **Isochronous cycle timer**

Type: Read/Write/Update

Offset: F0h

Default: XXXX XXXXh

Description: This read/write register indicates the current cycle number and offset. When the PCI4450 is cycle master, this register is transmitted with the cycle start message. When the PCI4450 is not cycle master, this register is loaded with the data field in an incoming cycle start. In the event that the cycle start message is not received, the fields can continue incrementing on their own (if programmed) to maintain a local time reference.

**Table 118. Isochronous Cycle Timer Register Description**

BIT	FIELD NAME	TYPE	DESCRIPTION
31–25	cycleSeconds	RWU	This field counts seconds (cycleCount rollovers) modulo 128.
24–12	cycleCount	RWU	This field counts cycles (cycleOffset rollovers) modulo 8000.
11–0	cycleOffset	RWU	This field counts 24.576 MHz clocks modulo 3072, i.e., 125 μs. If an external 8 kHz clock configuration is being used, then cycleOffset must be set to 0 at each tick of the external clock.

# PCI4450 GFN/GJG PC Card and OHCI Controller

SCPS046 – JANUARY 1999

## asynchronous request filter high register

Bit	31	30	29	28	27	26	25	24	23	22	21	20	19	18	17	16
Name	Asynchronous request filter high															
Type	RSC	RSC	RSC	RSC	RSC	RSC	RSC	RSC	RSC	RSC	RSC	RSC	RSC	RSC	RSC	RSC
Default	0	0	0	0	0	0	0	0	0	0	0	0	0	0	0	0
Bit	15	14	13	12	11	10	9	8	7	6	5	4	3	2	1	0
Name	Asynchronous request filter high															
Type	RSC	RSC	RSC	RSC	RSC	RSC	RSC	RSC	RSC	RSC	RSC	RSC	RSC	RSC	RSC	RSC
Default	0	0	0	0	0	0	0	0	0	0	0	0	0	0	0	0

Register: **Asynchronous request filter high**  
 Type: Read/Set/Clear  
 Offset: 100h set register  
           104h clear register  
 Default: 0000 0000h  
 Description: This set/clear register is used to enable asynchronous receive requests on a per node basis, and handles the upper node IDs. When a packet is destined for either the physical request context or the ARRQ context, the source node ID is examined. If the bit corresponding to the node ID is not set in this register, then the packet is not acknowledged and the request is not queued. The node ID comparison is done if the source node is on the same bus as the PCI4450. All nonlocal bus sourced packets are not acknowledged unless bit 31 in this register is set.

**Table 119. Asynchronous Request Filter High Register Description**

BIT	FIELD NAME	TYPE	DESCRIPTION
31	asynReqAllBuses	RSC	If set to 1, all asynchronous requests received by the PCI4450 from nonlocal bus nodes will be accepted.
30	asynReqResource62	RSC	If set to 1 for local bus node number 62, asynchronous requests received by the PCI4450 from that node will be accepted.
29	asynReqResource61	RSC	If set to 1 for local bus node number 61, asynchronous requests received by the PCI4450 from that node will be accepted.
28	asynReqResource60	RSC	If set to 1 for local bus node number 60, asynchronous requests received by the PCI4450 from that node will be accepted.
27	asynReqResource59	RSC	If set to 1 for local bus node number 59, asynchronous requests received by the PCI4450 from that node will be accepted.
26	asynReqResource58	RSC	If set to 1 for local bus node number 58, asynchronous requests received by the PCI4450 from that node will be accepted.
25	asynReqResource57	RSC	If set to 1 for local bus node number 57, asynchronous requests received by the PCI4450 from that node will be accepted.
24	asynReqResource56	RSC	If set to 1 for local bus node number 56, asynchronous requests received by the PCI4450 from that node will be accepted.
23	asynReqResource55	RSC	If set to 1 for local bus node number 55, asynchronous requests received by the PCI4450 from that node will be accepted.
22	asynReqResource54	RSC	If set to 1 for local bus node number 54, asynchronous requests received by the PCI4450 from that node will be accepted.
21	asynReqResource53	RSC	If set to 1 for local bus node number 53, asynchronous requests received by the PCI4450 from that node will be accepted.
20	asynReqResource52	RSC	If set to 1 for local bus node number 52, asynchronous requests received by the PCI4450 from that node will be accepted.





**Table 119. Asynchronous Request Filter High Register Description (Continued)**

BIT	FIELD NAME	TYPE	DESCRIPTION
19	asynReqResource51	RSC	If set to 1 for local bus node number 51, asynchronous requests received by the PCI4450 from that node will be accepted.
18	asynReqResource50	RSC	If set to 1 for local bus node number 50, asynchronous requests received by the PCI4450 from that node will be accepted.
17	asynReqResource49	RSC	If set to 1 for local bus node number 49, asynchronous requests received by the PCI4450 from that node will be accepted.
16	asynReqResource48	RSC	If set to 1 for local bus node number 48, asynchronous requests received by the PCI4450 from that node will be accepted.
15	asynReqResource47	RSC	If set to 1 for local bus node number 47, asynchronous requests received by the PCI4450 from that node will be accepted.
14	asynReqResource46	RSC	If set to 1 for local bus node number 46, asynchronous requests received by the PCI4450 from that node will be accepted.
13	asynReqResource45	RSC	If set to 1 for local bus node number 45, asynchronous requests received by the PCI4450 from that node will be accepted.
12	asynReqResource44	RSC	If set to 1 for local bus node number 44, asynchronous requests received by the PCI4450 from that node will be accepted.
11	asynReqResource43	RSC	If set to 1 for local bus node number 43, asynchronous requests received by the PCI4450 from that node will be accepted.
10	asynReqResource42	RSC	If set to 1 for local bus node number 42, asynchronous requests received by the PCI4450 from that node will be accepted.
9	asynReqResource41	RSC	If set to 1 for local bus node number 41, asynchronous requests received by the PCI4450 from that node will be accepted.
8	asynReqResource40	RSC	If set to 1 for local bus node number 40, asynchronous requests received by the PCI4450 from that node will be accepted.
7	asynReqResource39	RSC	If set to 1 for local bus node number 39, asynchronous requests received by the PCI4450 from that node will be accepted.
6	asynReqResource38	RSC	If set to 1 for local bus node number 38, asynchronous requests received by the PCI4450 from that node will be accepted.
5	asynReqResource37	RSC	If set to 1 for local bus node number 37, asynchronous requests received by the PCI4450 from that node will be accepted.
4	asynReqResource36	RSC	If set to 1 for local bus node number 36, asynchronous requests received by the PCI4450 from that node will be accepted.
3	asynReqResource35	RSC	If set to 1 for local bus node number 35, asynchronous requests received by the PCI4450 from that node will be accepted.
2	asynReqResource34	RSC	If set to 1 for local bus node number 34, asynchronous requests received by the PCI4450 from that node will be accepted.
1	asynReqResource33	RSC	If set to 1 for local bus node number 33, asynchronous requests received by the PCI4450 from that node will be accepted.
0	asynReqResource32	RSC	If set to 1 for local bus node number 32, asynchronous requests received by the PCI4450 from that node will be accepted.

# PCI4450 GFN/GJG PC Card and OHCI Controller

SCPS046 – JANUARY 1999

## asynchronous request filter low register

<b>Bit</b>	<b>31</b>	<b>30</b>	<b>29</b>	<b>28</b>	<b>27</b>	<b>26</b>	<b>25</b>	<b>24</b>	<b>23</b>	<b>22</b>	<b>21</b>	<b>20</b>	<b>19</b>	<b>18</b>	<b>17</b>	<b>16</b>
<b>Name</b>	Asynchronous request filter low															
<b>Type</b>	RSC	RSC	RSC	RSC	RSC	RSC	RSC	RSC	RSC	RSC	RSC	RSC	RSC	RSC	RSC	RSC
<b>Default</b>	0	0	0	0	0	0	0	0	0	0	0	0	0	0	0	0
<b>Bit</b>	<b>15</b>	<b>14</b>	<b>13</b>	<b>12</b>	<b>11</b>	<b>10</b>	<b>9</b>	<b>8</b>	<b>7</b>	<b>6</b>	<b>5</b>	<b>4</b>	<b>3</b>	<b>2</b>	<b>1</b>	<b>0</b>
<b>Name</b>	Asynchronous request filter low															
<b>Type</b>	RSC	RSC	RSC	RSC	RSC	RSC	RSC	RSC	RSC	RSC	RSC	RSC	RSC	RSC	RSC	RSC
<b>Default</b>	0	0	0	0	0	0	0	0	0	0	0	0	0	0	0	0

Register: **Asynchronous request filter low**

Type: Read/Set/Clear

Offset: 108h set register  
10Ch clear register

Default: 0000 0000h

Description: This set/clear register is used to enable asynchronous receive requests on a per node basis, and handles the lower node IDs. Other than filtering different node IDs, this register behaves identical to the asynchronous request filter high register.

**Table 120. Asynchronous Request Filter Low Register Description**

<b>BIT</b>	<b>FIELD NAME</b>	<b>TYPE</b>	<b>DESCRIPTION</b>
31	asynReqResource31	RSC	If set to 1 for local bus node number 31, asynchronous requests received by the PCI4450 from that node will be accepted.
30	asynReqResource30	RSC	If set to 1 for local bus node number 30, asynchronous requests received by the PCI4450 from that node will be accepted.
:	:	:	Bits 29 through 2 follow the same pattern.
1	asynReqResource1	RSC	If set to 1 for local bus node number 1, asynchronous requests received by the PCI4450 from that node will be accepted.
0	asynReqResource0	RSC	If set to 1 for local bus node number 0, asynchronous requests received by the PCI4450 from that node will be accepted.



**physical request filter high register**

<b>Bit</b>	31	30	29	28	27	26	25	24	23	22	21	20	19	18	17	16
<b>Name</b>	Physical request filter high															
<b>Type</b>	RSC	RSC	RSC	RSC	RSC	RSC	RSC	RSC	RSC	RSC	RSC	RSC	RSC	RSC	RSC	RSC
<b>Default</b>	0	0	0	0	0	0	0	0	0	0	0	0	0	0	0	0
<b>Bit</b>	15	14	13	12	11	10	9	8	7	6	5	4	3	2	1	0
<b>Name</b>	Physical request filter high															
<b>Type</b>	RSC	RSC	RSC	RSC	RSC	RSC	RSC	RSC	RSC	RSC	RSC	RSC	RSC	RSC	RSC	RSC
<b>Default</b>	0	0	0	0	0	0	0	0	0	0	0	0	0	0	0	0

Register: **Physical request filter high**

Type: Read/Set/Clear

Offset: 110h set register  
114h clear register

Default: 0000 0000h

Description: This set/clear register is used to enable physical receive requests on a per node basis, and handles the upper node IDs. When a packet is destined for the physical request context, and the node ID has been compared against the ARRQ registers, then the comparison is done again with this register. If the bit corresponding to the node ID is not set in this register, then the request will be handled by the ARRQ context instead of the physical request context.

**Table 121. Physical Request Filter High Register Description**

BIT	FIELD NAME	TYPE	DESCRIPTION
31	physReqAllBusses	RSC	If set to 1, then all asynchronous requests received by the PCI4450 from nonlocal bus nodes will be accepted.
30	physReqResource62	RSC	If set to 1 for local bus node number 62, then physical requests received by the PCI4450 from that node will be handled through the physical request context.
29	physReqResource61	RSC	If set to 1 for local bus node number 61, then physical requests received by the PCI4450 from that node will be handled through the physical request context.
28	physReqResource60	RSC	If set to 1 for local bus node number 60, then physical requests received by the PCI4450 from that node will be handled through the physical request context.
27	physReqResource59	RSC	If set to 1 for local bus node number 59, then physical requests received by the PCI4450 from that node will be handled through the physical request context.
26	physReqResource58	RSC	If set to 1 for local bus node number 58, then physical requests received by the PCI4450 from that node will be handled through the physical request context.
25	physReqResource57	RSC	If set to 1 for local bus node number 57, then physical requests received by the PCI4450 from that node will be handled through the physical request context.
24	physReqResource56	RSC	If set to 1 for local bus node number 56, then physical requests received by the PCI4450 from that node will be handled through the physical request context.
23	physReqResource55	RSC	If set to 1 for local bus node number 55, then physical requests received by the PCI4450 from that node will be handled through the physical request context.
22	physReqResource54	RSC	If set to 1 for local bus node number 54, then physical requests received by the PCI4450 from that node will be handled through the physical request context.
21	physReqResource53	RSC	If set to 1 for local bus node number 53, then physical requests received by the PCI4450 from that node will be handled through the physical request context.
20	physReqResource52	RSC	If set to 1 for local bus node number 52, then physical requests received by the PCI4450 from that node will be handled through the physical request context.
19	physReqResource51	RSC	If set to 1 for local bus node number 51, then physical requests received by the PCI4450 from that node will be handled through the physical request context.

# PCI4450 GFN/GJG PC Card and OHCI Controller

SCPS046 – JANUARY 1999

**Table 121. Physical Request Filter High Register Description (Continued)**

BIT	FIELD NAME	TYPE	DESCRIPTION
18	physReqResource50	RSC	If set to 1 for local bus node number 50, then physical requests received by the PCI4450 from that node will be handled through the physical request context.
17	physReqResource49	RSC	If set to 1 for local bus node number 49, then physical requests received by the PCI4450 from that node will be handled through the physical request context.
16	physReqResource48	RSC	If set to 1 for local bus node number 48, then physical requests received by the PCI4450 from that node will be handled through the physical request context.
15	physReqResource47	RSC	If set to 1 for local bus node number 47, then physical requests received by the PCI4450 from that node will be handled through the physical request context.
14	physReqResource46	RSC	If set to 1 for local bus node number 46, then physical requests received by the PCI4450 from that node will be handled through the physical request context.
13	physReqResource45	RSC	If set to 1 for local bus node number 45, then physical requests received by the PCI4450 from that node will be handled through the physical request context.
12	physReqResource44	RSC	If set to 1 for local bus node number 44, then physical requests received by the PCI4450 from that node will be handled through the physical request context.
11	physReqResource43	RSC	If set to 1 for local bus node number 43, then physical requests received by the PCI4450 from that node will be handled through the physical request context.
10	physReqResource42	RSC	If set to 1 for local bus node number 42, then physical requests received by the PCI4450 from that node will be handled through the physical request context.
9	physReqResource41	RSC	If set to 1 for local bus node number 41, then physical requests received by the PCI4450 from that node will be handled through the physical request context.
8	physReqResource40	RSC	If set to 1 for local bus node number 40, then physical requests received by the PCI4450 from that node will be handled through the physical request context.
7	physReqResource39	RSC	If set to 1 for local bus node number 39, then physical requests received by the PCI4450 from that node will be handled through the physical request context.
6	physReqResource38	RSC	If set to 1 for local bus node number 38, then physical requests received by the PCI4450 from that node will be handled through the physical request context.
5	physReqResource37	RSC	If set to 1 for local bus node number 37, then physical requests received by the PCI4450 from that node will be handled through the physical request context.
4	physReqResource36	RSC	If set to 1 for local bus node number 36, then physical requests received by the PCI4450 from that node will be handled through the physical request context.
3	physReqResource35	RSC	If set to 1 for local bus node number 35, then physical requests received by the PCI4450 from that node will be handled through the physical request context.
2	physReqResource34	RSC	If set to 1 for local bus node number 34, then physical requests received by the PCI4450 from that node will be handled through the physical request context.
1	physReqResource33	RSC	If set to 1 for local bus node number 33, then physical requests received by the PCI4450 from that node will be handled through the physical request context.
0	physReqResource32	RSC	If set to 1 for local bus node number 32, then physical requests received by the PCI4450 from that node will be handled through the physical request context.



POST OFFICE BOX 655303 • DALLAS, TEXAS 75265

**physical request filter low register**

<b>Bit</b>	31	30	29	28	27	26	25	24	23	22	21	20	19	18	17	16
<b>Name</b>	Physical request filter low															
<b>Type</b>	RSC	RSC	RSC	RSC	RSC	RSC	RSC	RSC	RSC	RSC	RSC	RSC	RSC	RSC	RSC	RSC
<b>Default</b>	0	0	0	0	0	0	0	0	0	0	0	0	0	0	0	0
<b>Bit</b>	15	14	13	12	11	10	9	8	7	6	5	4	3	2	1	0
<b>Name</b>	Physical request filter low															
<b>Type</b>	RSC	RSC	RSC	RSC	RSC	RSC	RSC	RSC	RSC	RSC	RSC	RSC	RSC	RSC	RSC	RSC
<b>Default</b>	0	0	0	0	0	0	0	0	0	0	0	0	0	0	0	0

Register: **Physical request filter low**

Type: Read/Set/Clear

Offset: 118h set register  
11Ch clear register

Default: 0000 0000h

Description: This set/clear register is used to enable physical receive requests on a per node basis, and handles the lower node IDs. When a packet is destined for the physical request context, and the node ID has been compared against the asynchronous request filter registers, then the node ID comparison is done again with this register. If the bit corresponding to the node ID is not set in this register, then the request will be handled by the asynchronous request context instead of the physical request context.

**Table 122. Physical Request Filter Low Register Description**

BIT	FIELD NAME	TYPE	DESCRIPTION
31	physReqResource31	RSC	If set to 1 for local bus node number 31, then physical requests received by the PCI4450 from that node will be handled through the physical request context.
30	physReqResource30	RSC	If set to 1 for local bus node number 30, then physical requests received by the PCI4450 from that node will be handled through the physical request context.
:	:	:	Bits 29 through 2 follow the same pattern.
1	physReqResource1	RSC	If set to 1 for local bus node number 1, then physical requests received by the PCI4450 from that node will be handled through the physical request context.
0	physReqResource0	RSC	If set to 1 for local bus node number 0, then physical requests received by the PCI4450 from that node will be handled through the physical request context.

# PCI4450 GFN/GJG PC Card and OHCI Controller

SCPS046 – JANUARY 1999

## physical upper bound register (optional register)

<b>Bit</b>	<b>31</b>	<b>30</b>	<b>29</b>	<b>28</b>	<b>27</b>	<b>26</b>	<b>25</b>	<b>24</b>	<b>23</b>	<b>22</b>	<b>21</b>	<b>20</b>	<b>19</b>	<b>18</b>	<b>17</b>	<b>16</b>
<b>Name</b>	Physical upper bound															
<b>Type</b>	R	R	R	R	R	R	R	R	R	R	R	R	R	R	R	R
<b>Default</b>	0	0	0	0	0	0	0	0	0	0	0	0	0	0	0	0
<b>Bit</b>	<b>15</b>	<b>14</b>	<b>13</b>	<b>12</b>	<b>11</b>	<b>10</b>	<b>9</b>	<b>8</b>	<b>7</b>	<b>6</b>	<b>5</b>	<b>4</b>	<b>3</b>	<b>2</b>	<b>1</b>	<b>0</b>
<b>Name</b>	Physical upper bound															
<b>Type</b>	R	R	R	R	R	R	R	R	R	R	R	R	R	R	R	R
<b>Default</b>	0	0	0	0	0	0	0	0	0	0	0	0	0	0	0	0

Register: **Physical upper bound**

Type: Read-only

Offset: 120h

Default: 0000 0000h

Description: This register is an optional register and is not implemented. This register is read-only and returns all 0s.



**asynchronous context control register**

<b>Bit</b>	31	30	29	28	27	26	25	24	23	22	21	20	19	18	17	16
<b>Name</b>	Asynchronous context control															
<b>Type</b>	R	R	R	R	R	R	R	R	R	R	R	R	R	R	R	R
<b>Default</b>	0	0	0	0	0	0	0	0	0	0	0	0	0	0	0	0
<b>Bit</b>	15	14	13	12	11	10	9	8	7	6	5	4	3	2	1	0
<b>Name</b>	Asynchronous context control															
<b>Type</b>	RSCU	R	R	RSU	RU	RU	R	R	RU	RU	RU	RU	RU	RU	RU	RU
<b>Default</b>	0	0	0	X	0	0	0	0	X	X	X	X	X	X	X	X

Register: **Asynchronous context control**

Type: Read/Set/Clear/Update

Offset: 180h set register [ATRQ]  
 184h clear register [ATRQ]  
 1A0h set register [ATRS]  
 1A4h clear register [ATRS]  
 1C0h set register [ARRQ]  
 1C4h clear register [ARRQ]  
 1E0h set register [ATRS]  
 1E4h clear register [ATRS]

Default: 0000 X0XXh

Description: This set/clear register controls the state and indicates status of the DMA context.

**Table 123. Asynchronous Context Control Register Description**

BIT	FIELD NAME	TYPE	DESCRIPTION
31–16	RSVD	R	Reserved. These bits return 0s when read.
15	run	RSCU	This bit is set by software to enable descriptor processing for the context and cleared by software to stop descriptor processing. The PCI4450 will only change this bit on a hardware or software reset.
14–13	RSVD	R	Reserved. These bits return 0s when read.
12	wake	RSU	Software sets this bit to cause the PCI4450 to continue or resume descriptor processing. The PCI4450 will clear this bit on every descriptor fetch.
11	dead	RU	The PCI4450 sets this bit when it encounters a fatal error and clears the bit when software resets the run bit.
10	active	RU	The PCI4450 sets this bit to 1 when it is processing descriptors.
9–8	RSVD	R	Reserved. These bits return 0s when read.
7–5	spd	RU	This field indicates the speed at which a packet was received or transmitted, and only contains meaningful information for receive contexts. This field is encoded as: 000b = 100 Mbits/sec, 001b = 200 Mbits/sec, 010b = 400 Mbits/sec, and all other values are reserved.
4–0	eventcode	RU	This field holds the acknowledge sent by the link core for this packet or an internally generated error code if the packet was not transferred successfully.

# PCI4450 GFN/GJG PC Card and OHCI Controller

SCPS046 – JANUARY 1999

## asynchronous context command pointer register

<b>Bit</b>	<b>31</b>	<b>30</b>	<b>29</b>	<b>28</b>	<b>27</b>	<b>26</b>	<b>25</b>	<b>24</b>	<b>23</b>	<b>22</b>	<b>21</b>	<b>20</b>	<b>19</b>	<b>18</b>	<b>17</b>	<b>16</b>
<b>Name</b>	Asynchronous context command pointer															
<b>Type</b>	RWU	RWU	RWU	RWU	RWU	RWU	RWU	RWU	RWU	RWU	RWU	RWU	RWU	RWU	RWU	RWU
<b>Default</b>	X	X	X	X	X	X	X	X	X	X	X	X	X	X	X	X
<b>Bit</b>	<b>15</b>	<b>14</b>	<b>13</b>	<b>12</b>	<b>11</b>	<b>10</b>	<b>9</b>	<b>8</b>	<b>7</b>	<b>6</b>	<b>5</b>	<b>4</b>	<b>3</b>	<b>2</b>	<b>1</b>	<b>0</b>
<b>Name</b>	Asynchronous context command pointer															
<b>Type</b>	RWU	RWU	RWU	RWU	RWU	RWU	RWU	RWU	RWU	RWU	RWU	RWU	RWU	RWU	RWU	RWU
<b>Default</b>	X	X	X	X	X	X	X	X	X	X	X	X	X	X	X	X

Register: **Asynchronous context command pointer**

Type: Read/Write/Update

Offset: 19Ch [ATRQ]

1ACh [ATRS]

1CCh [ATRQ]

1ECh [ATRS]

Default: XXXX XXXXh

Description: This register contains a pointer to the address of the first descriptor block that the PCI4450 will access when software enables the context by setting the ContextControl.run bit.

**Table 124. Asynchronous Context Command Pointer Register Description**

<b>BIT</b>	<b>FIELD NAME</b>	<b>TYPE</b>	<b>DESCRIPTION</b>
31–4	descriptorAddress	RWU	Contains the upper 28 bits of the address of a 16-byte aligned descriptor block.
3–0	Z	RWU	Indicates the number of contiguous descriptors at the address pointed to by the descriptor address. If Z is 0, it indicates that the descriptorAddress is not valid.





**isochronous transmit context control register**

<b>Bit</b>	31	30	29	28	27	26	25	24	23	22	21	20	19	18	17	16
<b>Name</b>	Isochronous transmit context control															
<b>Type</b>	RSCU	RSC	RSC	RSC	RSC	RSC	RSC	RSC	RSC	RSC	RSC	RSC	RSC	RSC	RSC	RSC
<b>Default</b>	X	X	X	X	X	X	X	X	X	X	X	X	X	X	X	X
<b>Bit</b>	15	14	13	12	11	10	9	8	7	6	5	4	3	2	1	0
<b>Name</b>	Isochronous transmit context control															
<b>Type</b>	RSC	R	R	RSU	RU	RU	R	R	RU	RU	RU	RU	RU	RU	RU	RU
<b>Default</b>	0	0	0	X	0	0	0	0	X	X	X	X	X	X	X	X

Register: **Isochronous transmit context control**

Type: Read/Set/Clear/Update

Offset: 200h + (16 \* n) set register  
204h + (16 \* n) clear register

Default: XXXX X0XXh

Description: This set/clear register controls options, state, and status for the isochronous transmit DMA contexts. The n value in the following register addresses indicates the context number (n = 0, 1, 2, 3, ...).

**Table 125. Isochronous Transmit Context Control Register Description**

BIT	FIELD NAME	TYPE	DESCRIPTION
31	cycleMatchEnable	RSCU	When set to 1, processing will occur such that the packet described by the context's first descriptor block will be transmitted in the cycle whose number is specified in the cycleMatch field of this register. The 13-bit cycleMatch field must match the 13-bit cycleCount field in the cycle start packet that is sent or received immediately before isochronous transmission begins.
30–16	cycleMatch	RSC	Contains a 15-bit value, corresponding to the lower order 2 bits of cycleSeconds and 13-bit cycleCount field. If cycleMatchEnable is set, then this IT DMA context will become enabled for transmits when the bus cycleCount value equals the cycleMatch value.
15	run	RSC	This bit is set by software to enable descriptor processing for the context and cleared by software to stop descriptor processing. The PCI4450 will only change this bit on a hardware or software reset.
14–13	RSVD	R	Reserved. These bits return 0s when read.
12	wake	RSU	Software sets this bit to cause the PCI4450 to continue or resume descriptor processing. The PCI4450 will clear this bit on every descriptor fetch.
11	dead	RU	The PCI4450 sets this bit when it encounters a fatal error, and clears the bit when software resets the run bit.
10	active	RU	The PCI4450 sets this bit to 1 when it is processing descriptors.
9–8	RSVD	R	Reserved. These bits return 0s when read.
7–5	spd	RU	This field is not meaningful for isochronous transmit contexts.
4–0	event code	RU	Following an OUTPUT_LAST* command, the error code is indicated in this field. Possible values are: ack_complete, evt_descriptor_read, evt_data_read, and evt_unknown.

# PCI4450 GFN/GJG PC Card and OHCI Controller

SCPS046 – JANUARY 1999

## isochronous transmit context command pointer register

<b>Bit</b>	<b>31</b>	<b>30</b>	<b>29</b>	<b>28</b>	<b>27</b>	<b>26</b>	<b>25</b>	<b>24</b>	<b>23</b>	<b>22</b>	<b>21</b>	<b>20</b>	<b>19</b>	<b>18</b>	<b>17</b>	<b>16</b>
<b>Name</b>	Isochronous transmit context command pointer															
<b>Type</b>	R	R	R	R	R	R	R	R	R	R	R	R	R	R	R	R
<b>Default</b>	X	X	X	X	X	X	X	X	X	X	X	X	X	X	X	X
<b>Bit</b>	<b>15</b>	<b>14</b>	<b>13</b>	<b>12</b>	<b>11</b>	<b>10</b>	<b>9</b>	<b>8</b>	<b>7</b>	<b>6</b>	<b>5</b>	<b>4</b>	<b>3</b>	<b>2</b>	<b>1</b>	<b>0</b>
<b>Name</b>	Isochronous transmit context command pointer															
<b>Type</b>	R	R	R	R	R	R	R	R	R	R	R	R	R	R	R	R
<b>Default</b>	X	X	X	X	X	X	X	X	X	X	X	X	X	X	X	X

Register: **Isochronous transmit context command pointer**

Type: Read-only

Offset: 20Ch + (16 \* n)

Default: XXXX XXXXh

Description: This register contains a pointer to the address of the first descriptor block that the PCI4450 will access when software enables an ISO transmit context by setting the ContextControl.run bit. The n value in the following register addresses indicates the context number (n = 0, 1, 2, 3, ...).



**isochronous receive context control register**

<b>Bit</b>	<b>31</b>	<b>30</b>	<b>29</b>	<b>28</b>	<b>27</b>	<b>26</b>	<b>25</b>	<b>24</b>	<b>23</b>	<b>22</b>	<b>21</b>	<b>20</b>	<b>19</b>	<b>18</b>	<b>17</b>	<b>16</b>
<b>Name</b>	Isochronous receive context control															
<b>Type</b>	RSC	RSC	RSCU	RSC	R	R	R	R	R	R	R	R	R	R	R	R
<b>Default</b>	X	X	X	X	0	0	0	0	0	0	0	0	0	0	0	0
<b>Bit</b>	<b>15</b>	<b>14</b>	<b>13</b>	<b>12</b>	<b>11</b>	<b>10</b>	<b>9</b>	<b>8</b>	<b>7</b>	<b>6</b>	<b>5</b>	<b>4</b>	<b>3</b>	<b>2</b>	<b>1</b>	<b>0</b>
<b>Name</b>	Isochronous receive context control															
<b>Type</b>	RSCU	R	R	RSU	RU	RU	R	R	RU	RU	RU	RU	RU	RU	RU	RU
<b>Default</b>	0	0	0	X	0	0	0	0	X	X	X	X	X	X	X	X

Register: **Isochronous receive context control**

Type: Read/Set/Clear/Update

Offset: 400h + (32 \* n) set register  
404h + (32 \* n) clear register

Default: X000 X0XXh

Description: This set/clear register controls options, state, and status for the isochronous receive DMA contexts. The n value in the following register addresses indicates the context number (n = 0, 1, 2, 3, ...).

**Table 126. Isochronous Receive Context Control**

BIT	FIELD NAME	TYPE	DESCRIPTION
31	bufferFill	RSC	When set, received packets are placed back-to-back to completely fill each receive buffer. When clear, each received packet is placed in a single buffer. If the multiChanMode bit is set to 1, this bit must also be set to 1. The value of bufferFill must not be changed while active or run are set.
30	isochHeader	RSC	When set to 1, received isochronous packets will include the complete 4-byte isochronous packet header seen by the link layer. The end of the packet will be marked with a xferStatus in the first doublet, and a 16-bit timeStamp indicating the time of the most recently received (or sent) cycleStart packet. When clear, the packet header is stripped off of received isochronous packets. The packet header, if received, immediately precedes the packet payload. The value of isochHeader must not be changed while active or run are set.
29	cycleMatchEnable	RSCU	When set, the context will begin running only when the 13-bit cycleMatch field in the contextMatch register matches the 13-bit cycleCount in the cycleStart packet. The effects of this bit, however, are impacted by the values of other bits in this register. Once the context has become active, hardware clears the cycleMatchEnable bit. The value of cycleMatchEnable must not be changed while active or run are set.
28	multiChanMode	RSC	When set, the corresponding isochronous receive DMA context will receive packets for all isochronous channels enabled in the IRChannelMaskHi and IRChannelMaskLo registers. The isochronous channel number specified in the IRDMA context match register is ignored. When 0, the IRDMA context will receive packets for that single channel. Only one IRDMA context may use the IRChannelMask registers. If more than one IRDMA context control register has the multiChanMode bit set, results are undefined. The value of multiChanMode must not be changed while active or run are set.
27–16	RSVD	R	Reserved. These bits return 0s when read.
15	run	RSCU	This bit is set by software to enable descriptor processing for the context and cleared by software to stop descriptor processing. The PCI4450 will only change this bit on a hardware or software reset.
14–13	RSVD	R	Reserved. These bits return 0s when read.
12	wake	RSU	Software sets this bit to cause the PCI4450 to continue or resume descriptor processing. The PCI4450 will clear this bit on every descriptor fetch.
11	dead	RU	The PCI4450 sets this bit when it encounters a fatal error, and clears the bit when software resets the run bit.
10	active	RU	The PCI4450 sets this bit to 1 when it is processing descriptors.

**Table 126. Isochronous Receive Context Control (Continued)**

9–8	RSVD	R	Reserved. These bits return 0s when read.
7–5	spd	RU	This field indicates the speed at which the packet was received. 3'b000 = 100 Mbits/sec, 3'b001 = 200 Mbits/sec, and 3'b010 = 400 Mbits/sec. All other values are reserved.
4–0	event code	RU	Following and INPUT* command, the error code is indicated in this field.

**isochronous receive context command pointer register**

<b>Bit</b>	31	30	29	28	27	26	25	24	23	22	21	20	19	18	17	16
<b>Name</b>	Isochronous receive context command pointer															
<b>Type</b>	R	R	R	R	R	R	R	R	R	R	R	R	R	R	R	R
<b>Default</b>	X	X	X	X	X	X	X	X	X	X	X	X	X	X	X	X
<b>Bit</b>	15	14	13	12	11	10	9	8	7	6	5	4	3	2	1	0
<b>Name</b>	Isochronous receive context command pointer															
<b>Type</b>	R	R	R	R	R	R	R	R	R	R	R	R	R	R	R	R
<b>Default</b>	X	X	X	X	X	X	X	X	X	X	X	X	X	X	X	X

Register: **Isochronous receive context command pointer**  
 Type: Read-only  
 Offset: 40Ch + (32 \* n)  
 Default: XXXX XXXXh  
 Description: This register contains a pointer to the address of the first descriptor block that the PCI4450 will access when software enables an ISO receive context by setting the ContextControl.run bit. The n value in the following register addresses indicates the context number (n = 0, 1, 2, 3, ...).

**isochronous receive context match register**

<b>Bit</b>	31	30	29	28	27	26	25	24	23	22	21	20	19	18	17	16
<b>Name</b>	Isochronous receive context match															
<b>Type</b>	R	R	R	R	R	R	R	R	R	R	R	R	R	R	R	R
<b>Default</b>	X	X	X	X	0	0	0	X	X	X	X	X	X	X	X	X
<b>Bit</b>	15	14	13	12	11	10	9	8	7	6	5	4	3	2	1	0
<b>Name</b>	Isochronous receive context match															
<b>Type</b>	R	R	R	R	R	R	R	R	R	R	R	R	R	R	R	R
<b>Default</b>	X	X	X	X	X	X	X	X	0	X	X	X	X	X	X	X

Register: **Isochronous receive context match**

Type: Read/Write

Offset: 410Ch + (32 \* n)

Default: XXXX XXXXh

Description: This register is used to start an isochronous receive context running on a specified cycle number, to filter incoming isochronous packets based on tag values, and to wait for packets with a specified sync value. The n value in the following register addresses indicates the context number (n = 0, 1, 2, 3, ...).

**Table 127. Isochronous Receive Context Match Register Description**

BIT	FIELD NAME	TYPE	DESCRIPTION
31	tag3	R/W	If set, this context will match on iso receive packets with a tag field of 2'b11.
30	tag2	R/W	If set, this context will match on iso receive packets with a tag field of 2'b10.
29	tag1	R/W	If set, this context will match on iso receive packets with a tag field of 2'b01.
28	tag0	R/W	If set, this context will match on iso receive packets with a tag field of 2'b00.
27–25	RSVD	R	Reserved. These bits return 0s when read.
24–12	cycleMatch	R/W	Contains a 13-bit value, corresponding to the 13-bit cycleCount field in the cycleStart packet. If cycleMatchEnable is set, then this context is enabled for receives when the bus cycleCount value equals the cycleMatch value.
11–8	sync	R/W	This field contains the 4-bit field which is compared to the sync field of each iso packet for this channel when the command descriptor's w field is set to 2'b11.
7	RSVD	R	Reserved. These bits return 0s when read.
6	tag1SyncFilter	R/W	If set and the tag1 bit is set, then packets with tag2b01 shall be accepted into the context if the two most significant bits of the packets sync field are 2'b00. Packets with tag values other than 2'b01 are filtered according to tag0, tag2 and tag3 without any additional restrictions. If clear, this context will match on isochronous receive packets as specified in the tag0–3 bits with no additional restrictions.
5–0	channelNumber	R/W	This 6-bit field indicates the isochronous channel number for which this IR DMA context will accept packets.

**GPIO interface**

The GPIO interface consists of four general-purpose input output ports. On power reset, GPIO0 and GPIO1 are enabled and are configured as bus manager contender (BMC) and link power status (LPS) , respectively. BMC and LPS outputs can be configured via the GPIO control register in PCI Configuration space, as GPIO0 and GPIO1. Figure 3 shows the schematic for GPIO0 and GPIO1 implementation.

GPIO2 and GPIO3 power up as general-purpose inputs and are programmable via the GPIO control register. Figure 4 shows the schematic for GPIO2 and GPIO3 implementation.

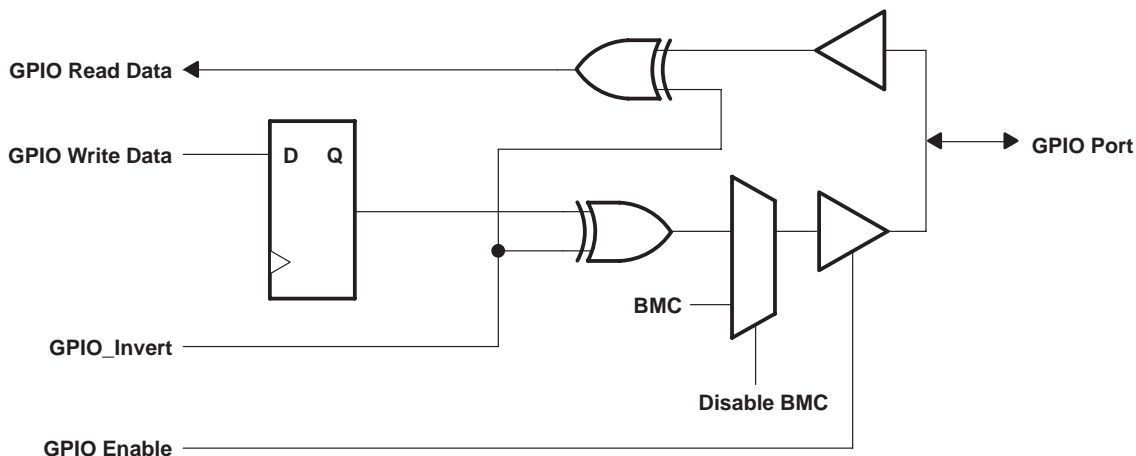

**Figure 22. BMC/LINKON/GPIO0**

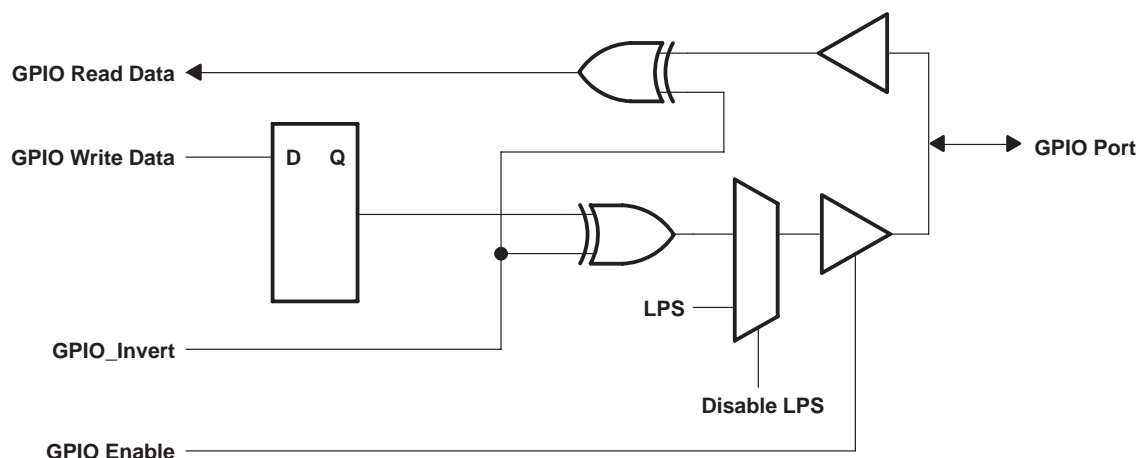

**Figure 23. LPS/GPIO1**

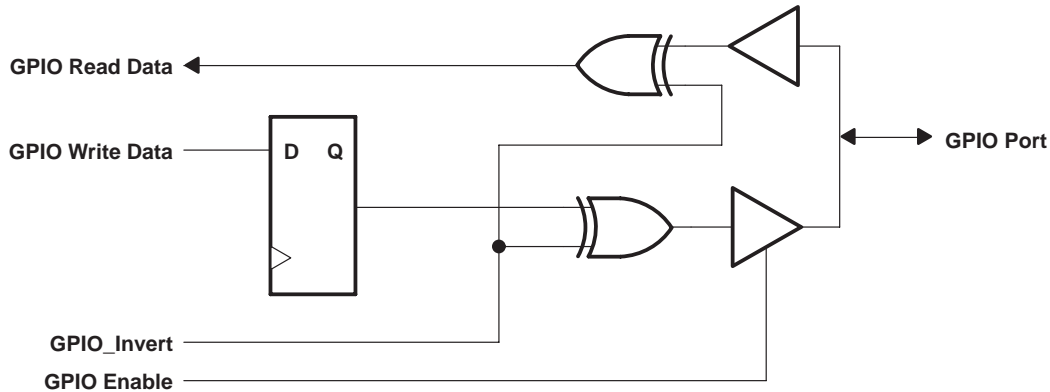

Figure 24. GPIO2 and GPIO3

## serial EEPROM

### serial bus interface

The PCI4450 provides a serial bus interface to initialize the 1394 Global Unique ID register and a few PCI configuration registers through a serial EEPROM. The PCI4450 communicates with the serial EEPROM via the 2-wire serial interface.

After power-up the serial interface initializes the locations listed in Table 128. While the PCI4450 is accessing the serial ROM, all incoming PCI Slave accesses are terminated with retry status. Table 129 shows the serial ROM memory map required for initializing the PCI4450 registers.

Table 128. Registers and Bits Loadable through Serial EEPROM

OFFSET	REGISTER	BITS LOADED FROM EEPROM
OHCI Register (24h)	1394 GlobalUniqueIDHi	31–0
OHCI Register(28h)	1394 GlobalUniqueIDLo	31–0
OHCI Register (50h)	Host Control Register	23
PCI Register (2Ch)	PCI Subsystem ID	15–0
PCI Register (2Dh)	PCI Vendor ID	15–0
PCI Register (3Eh)	PCI Maximum Latency, PCI Minimum Grant	15–0
PCI Register (F4h)	Link Enhancements Control Register	7, 2, 1

# PCI4450 GFN/GJG PC Card and OHCI Controller

SCPS046 – JANUARY 1999

**Table 129. Serial EEPROM Map**

BYTE ADDRESS	BYTE DESCRIPTION							
00	PCI maximum latency (4'h0)				PCI_Minimum grant (4'h0)			
01	PCI vendor ID							
02	PCI vendor ID (ms byte)							
03	PCI subsystem ID (ls byte)							
04	PCI subsystem ID							
05	[7] Link_enhancement- Control.enab_unfair	[6] HCControl. ProgramPhy Enable	[5] RSVD	[4] RSVD	[3] RSVD	[2] Link_enhancement- Control.enab_ insert_idle	[1] Link_enhancement- Control.enab_accel	[0] RSVD
06	Reserved							
07	1394 GlobalUniqueIDHi (ls byte 0)							
08	1394 GlobalUniqueIDHi (byte 1)							
09	1394 GlobalUniqueIDHi (byte 2)							
0A	1394 GlobalUniqueIDHi (ms byte 3)							
0B	1394 GlobalUniqueIDLo (ls byte 0)							
0C	1394 GlobalUniqueIDLo (byte 1)							
0D	1394 GlobalUniqueIDLo (byte 2)							
0E	1394 GlobalUniqueIDLo (ms byte 3)							





**absolute maximum ratings over operating temperature ranges (unless otherwise noted)†**

Supply voltage range, $V_{CC}$ .....	-0.5 V to 4.6 V
Clamping voltage range, $V_{CCP}$ , $V_{CCA}$ , $V_{CCB}$ .....	-0.5 V to 6 V
Input voltage range, $V_I$ : PCI .....	-0.5 V to $V_{CCP} + 0.5$ V
Card A .....	-0.5 V to $V_{CCA} + 0.5$ V
Card B .....	-0.5 V to $V_{CCB} + 0.5$ V
ZV .....	-0.5 V to $V_{CC} + 0.5$ V
TTL .....	-0.5 V to $V_{CC} + 0.5$ V
Fail safe .....	-0.5 V to $V_{CC} + 0.5$ V
Miscellaneous and Phy I/F .....	-0.5 to $V_{CC} + 0.5$ V
Output voltage range, $V_O$ : PCI .....	-0.5 V to $V_{CC} + 0.5$ V
Card A .....	-0.5 V to $V_{CCA} + 0.5$ V
Card B .....	-0.5 V to $V_{CCB} + 0.5$ V
ZV .....	-0.5 V to $V_{CC} + 0.5$ V
TTL .....	-0.5 V to $V_{CC} + 0.5$ V
Fail safe .....	-0.5 V to $V_{CC} + 0.5$ V
Miscellaneous and Phy I/F .....	-0.5 to $V_{CC} + 0.5$ V
Input clamp current, $I_{IK}$ ( $V_I < 0$ or $V_I > V_{CC}$ ) (see Note 1) .....	$\pm 20$ mA
Output clamp current, $I_{OK}$ ( $V_O < 0$ or $V_O > V_{CC}$ ) (see Note 2) .....	$\pm 20$ mA
Storage temperature range, $T_{stg}$ .....	-65°C to 150°C
Virtual junction temperature, $T_J$ .....	150°C

† Stresses beyond those listed under “absolute maximum ratings” may cause permanent damage to the device. These are stress ratings only, and functional operation of the device at these or any other conditions beyond those indicated under “recommended operating conditions” is not implied. Exposure to absolute-maximum-rated conditions for extended periods may affect device reliability.

- NOTES: 1. Applies for external input and bidirectional buffers.  $V_I > V_{CC}$  does not apply to fail-safe terminals. PCI terminals are measured with respect to  $V_{CCP}$  instead of  $V_{CC}$ . PC Card terminals are measured with respect to  $V_{CCA}$  or  $V_{CCB}$ . ZV terminals and TTL signals are measured with respect to  $V_{CC}$ . The limit specified applies for a dc condition.
2. Applies for external output and bidirectional buffers.  $V_O > V_{CC}$  does not apply to fail-safe terminals. PCI terminals are measured with respect to  $V_{CCP}$  instead of  $V_{CC}$ . PC Card terminals are measured with respect to  $V_{CCA}$  or  $V_{CCB}$ . ZV terminals and TTL signals are measured with respect to  $V_{CC}$ . The limit specified applies for a dc condition.

# PCI4450 GFN/GJG

## PC Card and OHCI Controller

SCPS046 – JANUARY 1999

### recommended operating conditions (see Note 3)

		OPERATION	MIN	NOM	MAX	UNIT
V <sub>CC</sub>	Core voltage	Commercial	3.3 V	3.3	3.6	V
V <sub>CCP</sub>	PCI I/O voltage, ZV Port I/O voltage	Commercial	3.3 V	3.3	3.6	V
			5 V	5	5.5	
V <sub>CCA/B</sub>	PC Card I/O voltage	Commercial	3.3 V	3.3	3.6	V
			5 V	4.75	5.25	
V <sub>IH</sub> †	High-level Input voltage	PCI	3.3 V	0.5 V <sub>CCP</sub>	V <sub>CCP</sub>	V
			5 V	2	V <sub>CCP</sub>	
		PC Card	3.3 V	0.475 V <sub>CCA/B</sub>	V <sub>CCA/B</sub>	V
			5 V	2.4	V <sub>CCA/B</sub>	
		PHY I/F		2	V <sub>CC</sub>	V
		TTL‡		2	V <sub>CC</sub>	V
Fail safe§		2.4	V <sub>CC</sub>	V		
V <sub>IL</sub> †	Low-level input voltage	PCI	3.3 V	0	0.3 V <sub>CCP</sub>	V
			5 V	0	0.8	
		PC Card	3.3 V	0	0.325 V <sub>CCA/B</sub>	V
			5 V	0	0.8	
		PHY I/F		0	0.8	V
		TTL‡		0	0.8	V
Fail safe§		0	0.8	V		
V <sub>I</sub>	Input voltage	PCI	3.3 V	0	V <sub>CCP</sub>	V
		PC Card	5 V	0	V <sub>CCA/B</sub>	
		PHY I/F		0	V <sub>CC</sub>	
		TTL‡		0	V <sub>CC</sub>	
		Fail safe§		0	V <sub>CC</sub>	
V <sub>O</sub> ¶	Output voltage	PCI	3.3 V	0	V <sub>CC</sub>	V
		PC Card	5 V	0	V <sub>CC</sub>	
		PHY I/F		0	V <sub>CC</sub>	
		TTL‡		0	V <sub>CC</sub>	
		Fail safe§		0	V <sub>CC</sub>	
t <sub>t</sub>	Input transition times (t <sub>r</sub> and t <sub>f</sub> )	PCI and PC Card		1	4	ns
		TTL and fail safe		0	6	
T <sub>A</sub>	Operating ambient temperature range		0	25	70	°C
T <sub>J</sub> #	Virtual junction temperature		0	25	115	°C

† Applies to external inputs and bidirectional buffers without hysteresis

‡ TTL 4 mA pins are A\_CVS1//A\_VS1, A\_CVS2//A\_VS2, B\_CVS1//B\_VS1, B\_CVS2//B\_VS2, CLOCK, DATA, LATCH, SPKROUT, MFUNC4–MFUNC0, SCL, SDA, ZV\_UVx, ZV\_PCLK, ZV\_SDATA, ZV\_LRCLK, ZV\_MCLK, ZV\_VSYNC, ZV\_HREF, ZV\_SCLK, ZV\_Yx, SUSPEND, LPS, PHY\_LREQ.

TTL 8 mA pins are MFUNC6, MFUNC5, PHY\_CTL0, PHY\_CTL1, PHY\_DATAx, and LINKON.

§ Fail-safe pin is RI\_OUT (open drain).

¶ Applies to external output buffers

# These junction temperatures reflect simulation conditions. The customer is responsible for verifying junction temperature.

NOTE 3: Unused pins (input or I/O) must be held high or low to prevent them from floating.



electrical characteristics over recommended operating conditions (unless otherwise noted)

PARAMETER	PINS	OPERATION	TEST CONDITIONS	MIN	MAX	UNIT
V <sub>OH</sub> High-level output voltage (see Note 4)	PCI	3.3 V	I <sub>OH</sub> = -0.5 mA	0.9 V <sub>CC</sub>		V
		5 V	I <sub>OH</sub> = -2 mA	2.4		
	PC Card	3.3 V	I <sub>OH</sub> = -0.15 mA	0.9 V <sub>CC</sub>		
		5 V	I <sub>OH</sub> = -0.15 mA	2.4		
	PHY I/F	3.3 V	I <sub>OH</sub> = -4 mA	2.8		
		3.3 V	I <sub>OL</sub> = -8 mA	V <sub>CC</sub> -0.6		
	TTL		I <sub>OH</sub> = -4 mA	V <sub>CC</sub> -0.6		
			I <sub>OH</sub> = -8 mA	V <sub>CC</sub> -0.6		
V <sub>OL</sub> Low-level output voltage	PCI	3.3 V	I <sub>OL</sub> = 1.5 mA	0.1 V <sub>CC</sub>		V
		5 V	I <sub>OL</sub> = 6 mA	0.55		
	PC Card	3.3 V	I <sub>OL</sub> = 0.7 mA	0.1 V <sub>CC</sub>		
		5 V	I <sub>OL</sub> = 0.7 mA	0.55		
	PHY I/F	3.3 V	I <sub>OL</sub> = 4 mA	0.5		V
		3.3 V	I <sub>OL</sub> = 8 mA	0.5		
	TTL		I <sub>OL</sub> = 4 mA	0.5		V
			I <sub>OL</sub> = 8 mA	0.5		
	$\overline{\text{SERR}}$		I <sub>OL</sub> = 8 mA	0.5		V
	I <sub>OZL</sub> 3-state output, high-impedance state current (see Note 4)	Output pins	3.6 V	V <sub>I</sub> = V <sub>CC</sub>		-1
5.25 V			V <sub>I</sub> = V <sub>CC</sub>		-1	
I <sub>OZH</sub> 3-state output, high-impedance state current	Output pins	3.6 V	V <sub>I</sub> = V <sub>CC</sub> <sup>†</sup>		10	μA
		5.25 V	V <sub>I</sub> = V <sub>CC</sub> <sup>†</sup>		25	
I <sub>IL</sub> Low-level input current	Input pins		V <sub>I</sub> = GND		-1	μA
	I/O pins		V <sub>I</sub> = GND		-10	
	Latch		V <sub>I</sub> = GND		-2	
I <sub>IH</sub> High-level input current (see Note 5)	Input pins	3.6 V	V <sub>I</sub> = V <sub>CC</sub> <sup>‡</sup>		10	μA
		5.25 V	V <sub>I</sub> = V <sub>CC</sub> <sup>‡</sup>		20	
	I/O pins	3.6 V	V <sub>I</sub> = V <sub>CC</sub> <sup>‡</sup>		10	
		5.25 V	V <sub>I</sub> = V <sub>CC</sub> <sup>‡</sup>		25	
	Fail-safe pins	3.6 V	V <sub>I</sub> = V <sub>CC</sub>		10	

<sup>†</sup> For PCI pins, V<sub>I</sub> = V<sub>CCP</sub>. For PC Card pins, V<sub>I</sub> = V<sub>CC(A/B)</sub>. For ZV pins, V<sub>I</sub> = V<sub>CC</sub>. For miscellaneous pins, V<sub>I</sub> = V<sub>CC</sub>.

<sup>‡</sup> For I/O pins, input leakage (I<sub>IL</sub> and I<sub>IH</sub>) includes I<sub>OZ</sub> leakage of the disabled output.

NOTES: 4. V<sub>OH</sub> and I<sub>OL</sub> are not tested on  $\overline{\text{SERR}}$  (GFN pin Y20, GJG pin W18) and RI\_OUT (GFN pin Y13, GJG pin R11) because they are open-drain outputs.

5. I<sub>IH</sub> is not tested on LATCH (GFN pin W12, GJG pin W11) because it is pulled up with an internal resistor.

# PCI4450 GFN/GJG PC Card and OHCI Controller

SCPS046 – JANUARY 1999

## PCI clock/reset timing requirements over recommended ranges of supply voltage and operating free-air temperature (see Figure 26 and Figure 27)

PARAMETER		ALTERNATE SYMBOL	TEST CONDITIONS	MIN	MAX	UNIT
$t_c$	Cycle time, PCLK	$t_{cyc}$		30		ns
$t_{wH}$	Pulse duration, PCLK high	$t_{high}$		11		ns
$t_{wL}$	Pulse duration, PCLK low	$t_{low}$		11		ns
$\Delta v/\Delta t$	Slew rate, PCLK	$t_r, t_f$		1	4	V/ns
$t_w$	Pulse duration, RSTIN	$t_{rst}$		1		ms
$t_{su}$	Setup time, PCLK active at end of $\overline{RSTIN}$	$t_{rst-clk}$		100		$\mu s$

## PCI timing requirements over recommended ranges of supply voltage and operating free-air temperature (see Note 7, Figure 25, and Figure 28)

PARAMETER		ALTERNATE SYMBOL	TEST CONDITIONS	MIN	MAX	UNIT
$t_{pd}$	PCLK-to-shared signal valid delay time	$t_{val}$	$C_L = 50 \text{ pF}$ , See Note 7		11	ns
	PCLK-to-shared signal invalid delay time	$t_{inv}$		2		
$t_{en}$	Enable time, high impedance-to-active delay time from PCLK	$t_{on}$		2		ns
$t_{dis}$	Disable time, active-to-high impedance delay time from PCLK	$t_{off}$			28	ns
$t_{su}$	Setup time before PCLK valid	$t_{su}$		7		ns
$t_h$	Hold time after PCLK high	$t_h$		0		ns

NOTES: 6. PCI shared signals are AD31–AD0, C/BE3–C/BE0, FRAME, TRDY, IRDY, STOP, IDSEL, DEVSEL, and PAR.

7. This data sheet uses the following conventions to describe time (  $t$  ) intervals. The format is  $t_A$ , where subscript  $A$  indicates the type of dynamic parameter being represented. One of the following is used:  $t_{pd}$  = propagation delay time,  $t_d$  = delay time,  $t_{su}$  = setup time, and  $t_h$  = hold time.

## Switching characteristics for PHY-Link interface

PARAMETER		MEASURED	MIN	TYP	MAX	UNIT
$t_{su}$	Setup time, Dn, CTLn, LREQ to PHY_CLK	–50% to 50%	6			ns
$t_h$	Hold time, Dn, CTLn, LREQ before PHY_CLK	–50% to 50%	1			
$t_d$	Delay time, PHY_CLK to Dn, CTLn	–50% to 50%	2		11	



PARAMETER MEASUREMENT INFORMATION

LOAD CIRCUIT PARAMETERS

TIMING PARAMETER		C <sub>LOAD</sub> <sup>†</sup> (pF)	I <sub>OL</sub> (mA)	I <sub>OH</sub> (mA)	V <sub>LOAD</sub> <sup>‡</sup> (V)
t <sub>en</sub>	t <sub>PZH</sub>	50	8	-8	0
	t <sub>PZL</sub>				3
t <sub>dis</sub>	t <sub>PHZ</sub>	50	8	-8	1.5
	t <sub>PLZ</sub>				
t <sub>pd</sub>		50	8	-8	‡

<sup>†</sup> C<sub>LOAD</sub> includes the typical load-circuit distributed capacitance.

<sup>‡</sup>  $\frac{V_{LOAD} - V_{OL}}{I_{OL}} = 50 \Omega$ , where V<sub>OL</sub> = 0.6 V, I<sub>OL</sub> = 8 mA

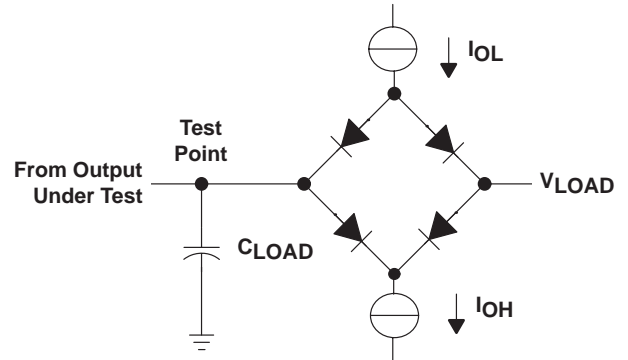

LOAD CIRCUIT

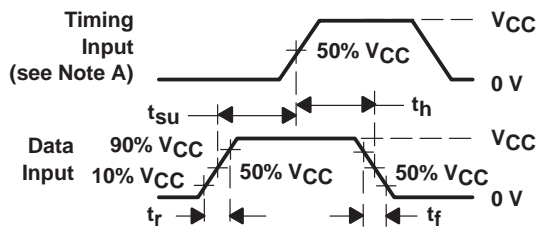

VOLTAGE WAVEFORMS  
SETUP AND HOLD TIMES  
INPUT RISE AND FALL TIMES

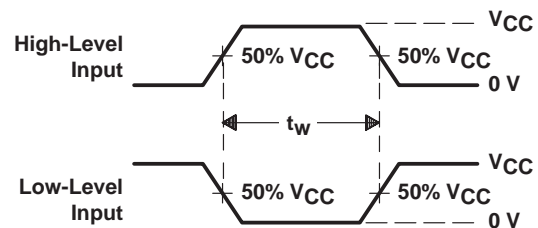

VOLTAGE WAVEFORMS  
PULSE DURATION

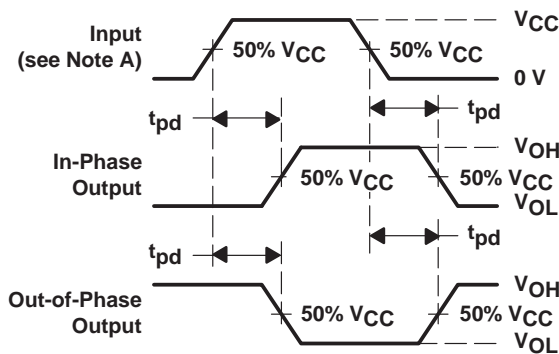

VOLTAGE WAVEFORMS  
PROPAGATION DELAY TIMES

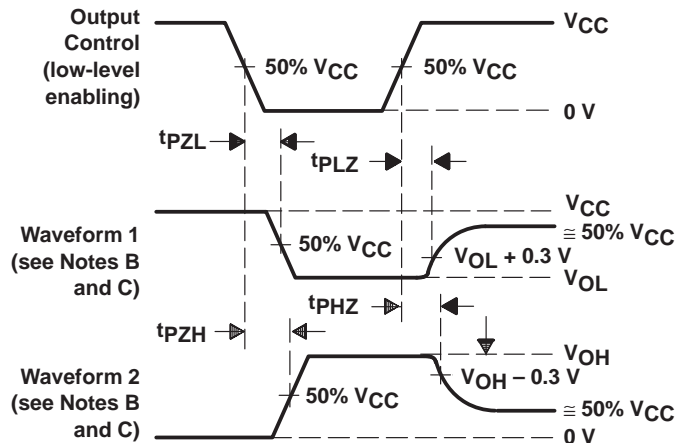

VOLTAGE WAVEFORMS  
ENABLE AND DISABLE TIMES, 3-STATE OUTPUTS

- NOTES: A. Phase relationships between waveforms were chosen arbitrarily. All input pulses are supplied by pulse generators having the following characteristics: PRR = 1 MHz, Z<sub>O</sub> = 50 Ω, t<sub>r</sub> = 6 ns.  
B. Waveform 1 is for an output with internal conditions such that the output is low except when disabled by the output control. Waveform 2 is for an output with internal conditions such that the output is high except when disabled by the output control.  
C. For t<sub>PLZ</sub> and t<sub>PHZ</sub>, V<sub>OL</sub> and V<sub>OH</sub> are measured values.

Figure 25. Load Circuit and Voltage Waveforms

PCI BUS PARAMETER MEASUREMENT INFORMATION

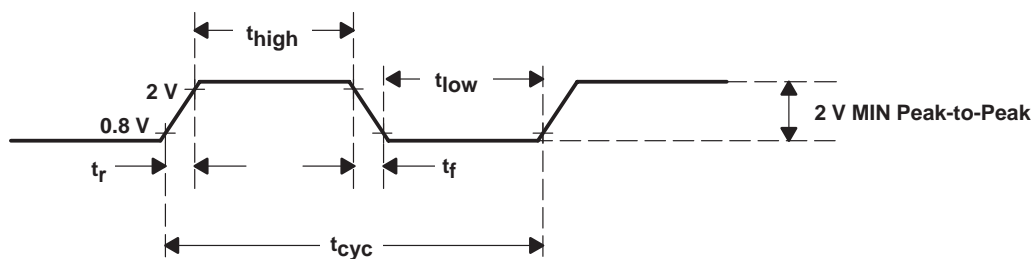

Figure 26. PCLK Timing Waveform

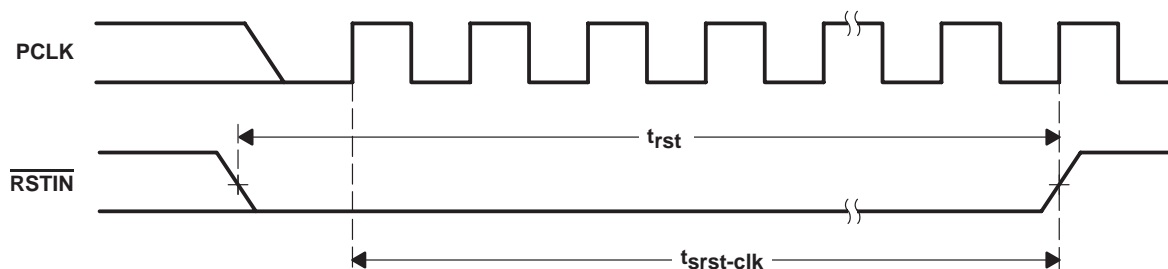

Figure 27.  $\overline{\text{RSTIN}}$  Timing Waveforms

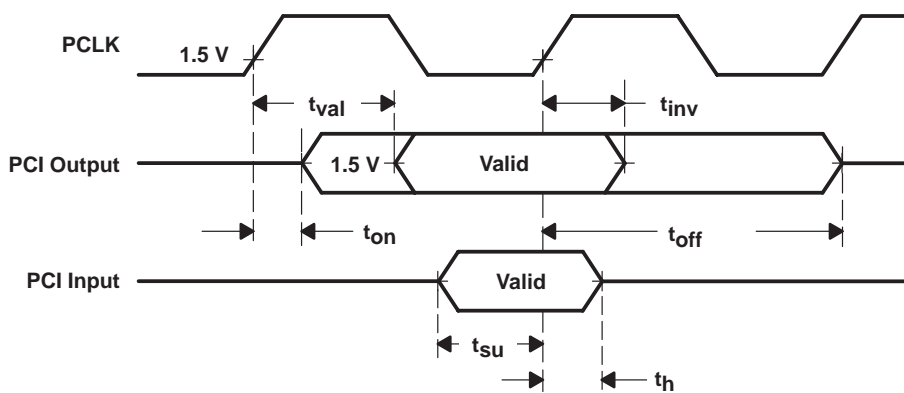

Figure 28. Shared Signals Timing Waveforms

## PC Card cycle timing

The PC Card cycle timing is controlled by the wait-state bits in the Intel 82365SL-DF compatible memory and I/O window registers. The PC Card cycle generator uses the PCI clock to generate the correct card address setup and hold times and the PC Card command active (low) interval. This allows the cycle generator to output PC Card cycles that are as close to the Intel 82365SL-DF timing as possible, while always slightly exceeding the Intel 82365SL-DF values. This ensures compatibility with existing software and maximizes throughput.

The PC Card address setup and hold times are a function of the wait-state bits. Table 130 shows address setup time in PCLK cycles and nanoseconds for I/O and memory cycles. Table 131 and Table 132 show command active time in PCLK cycles and nanoseconds for I/O and memory cycles. Table 133 shows address hold time in PCLK cycles and nanoseconds for I/O and memory cycles.

**Table 130. PC Card Address Setup Time,  $t_{su(A)}$ , 8-Bit and 16-Bit PCI Cycles**

WAIT-STATE BITS			TS1 – 0 = 01 (PCLK/ns)
I/O			3/90
Memory	WS1	0	2/60
Memory	WS1	1	4/120

**Table 131. PC Card Command Active Time,  $t_{c(A)}$ , 8-Bit PCI Cycles**

	WAIT-STATE BITS		TS1 – 0 = 01 (PCLK/ns)
	WS	ZWS	
I/O	0	0	19/570
	1	X	23/690
	0	1	7/210
Memory	00	0	19/570
	01	X	23/690
	10	X	23/690
	11	X	23/690
	00	1	7/210

**Table 132. PC Card Command Active Time,  $t_{c(A)}$ , 16-Bit PCI Cycles**

	WAIT-STATE BITS		TS1 – 0 = 01 (PCLK/ns)
	WS	ZWS	
I/O	0	0	7/210
	1	X	11/330
	0	1	N/A
Memory	00	0	9/270
	01	X	13/390
	10	X	17/510
	11	X	23/630
	00	1	5/150

# PCI4450 GFN/GJG PC Card and OHCI Controller

SCPS046 – JANUARY 1999

**Table 133. PC Card Address Hold Time,  $t_{h(A)}$ , 8-Bit and 16-Bit PCI Cycles**

WAIT-STATE BITS			TS1 – 0 = 01 (PCLK/ns)
I/O			2/60
Memory	WS1	0	2/60
Memory	WS1	1	3/90

**timing requirements over recommended ranges of supply voltage and operating free-air temperature, memory cycles (for 100-ns common memory) (see Note 8 and Figure 29)**

	ALTERNATE SYMBOL	MIN	MAX	UNIT
$t_{su}$ Setup time, $\overline{CE1}$ and $\overline{CE2}$ before $\overline{WE/OE}$ low	T1	60		ns
$t_{su}$ Setup time, CA25–CA0 before $\overline{WE/OE}$ low	T2	$t_{su(A)}+2PCLK$		ns
$t_{su}$ Setup time, $\overline{REG}$ before $\overline{WE/OE}$ low	T3	90		ns
$t_{pd}$ Propagation delay time, $\overline{WE/OE}$ low to $\overline{WAIT}$ low	T4			ns
$t_w$ Pulse duration, $\overline{WE/OE}$ low	T5	200		ns
$t_h$ Hold time, $\overline{WE/OE}$ low after $\overline{WAIT}$ high	T6			ns
$t_h$ Hold time, $\overline{CE1}$ and $\overline{CE2}$ after $\overline{WE/OE}$ high	T7	120		ns
$t_{su}$ Setup time (read), CDATA15–CDATA0 valid before $\overline{OE}$ high	T8			ns
$t_h$ Hold time (read), CDATA15–CDATA0 valid after $\overline{OE}$ high	T9	0		ns
$t_h$ Hold time, CA25–CA0 and $\overline{REG}$ after $\overline{WE/OE}$ high	T10	$t_{h(A)}+1PCLK$		ns
$t_{su}$ Setup time (write), CDATA15–CDATA0 valid before $\overline{WE}$ low	T11	60		ns
$t_h$ Hold time (write), CDATA15–CDATA0 valid after $\overline{WE}$ low	T12	240		ns

NOTE 8: These times are dependent on the register settings associated with ISA wait states and data size. They are also dependent on cycle type (read/write, memory/I/O) and WAIT from PC Card. The times listed here represent absolute minimums (the times that would be observed if programmed for zero wait state, 16-bit cycles) with a 33-MHz PCI clock.

**timing requirements over recommended ranges of supply voltage and operating free-air temperature, I/O cycles (see Figure 30)**

	ALTERNATE SYMBOL	MIN	MAX	UNIT
$t_{su}$ Setup time, $\overline{REG}$ before $\overline{IORD/IOWR}$ low	T13	60		ns
$t_{su}$ Setup time, $\overline{CE1}$ and $\overline{CE2}$ before $\overline{IORD/IOWR}$ low	T14	60		ns
$t_{su}$ Setup time, CA25–CA0 valid before $\overline{IORD/IOWR}$ low	T15	$t_{su(A)}+2PCLK$		ns
$t_{pd}$ Propagation delay time, $\overline{IOIS16}$ low after CA25–CA0 valid	T16		35	ns
$t_{pd}$ Propagation delay time, $\overline{IORD}$ low to $\overline{WAIT}$ low	T17	35		ns
$t_w$ Pulse duration, $\overline{IORD/IOWR}$ low	T18	$T_{cA}$		ns
$t_h$ Hold time, $\overline{IORD}$ low after $\overline{WAIT}$ high	T19			ns
$t_h$ Hold time, $\overline{REG}$ low after $\overline{IORD}$ high	T20	0		ns
$t_h$ Hold time, $\overline{CE1}$ and $\overline{CE2}$ after $\overline{IORD/IOWR}$ high	T21	120		ns
$t_h$ Hold time, CA25–CA0 after $\overline{IORD/IOWR}$ high	T22	$t_{h(A)}+1PCLK$		ns
$t_{su}$ Setup time (read), CDATA15–CDATA0 valid before $\overline{IORD}$ high	T23	10		ns
$t_h$ Hold time (read), CDATA15–CDATA0 valid after $\overline{IORD}$ high	T24	0		ns
$t_{su}$ Setup time (write), CDATA15–CDATA0 valid before $\overline{IOWR}$ low	T25	90		ns
$t_h$ Hold time (write), CDATA15–CDATA0 valid after $\overline{IOWR}$ high	T26	90		ns





switching characteristics over recommended ranges of supply voltage and operating free-air temperature, miscellaneous (see Figure 31)

PARAMETER		ALTERNATE SYMBOL	MIN	MAX	UNIT
$t_{pd}$	Propagation delay time	BVD2 low to SPKROUT low		30	ns
		BVD2 high to SPKROUT high		30	
		IREQ to IRQ15–IRQ3	T27	30	
		STSCHG to IRQ15–IRQ3	T28	30	

PC Card PARAMETER MEASUREMENT INFORMATION

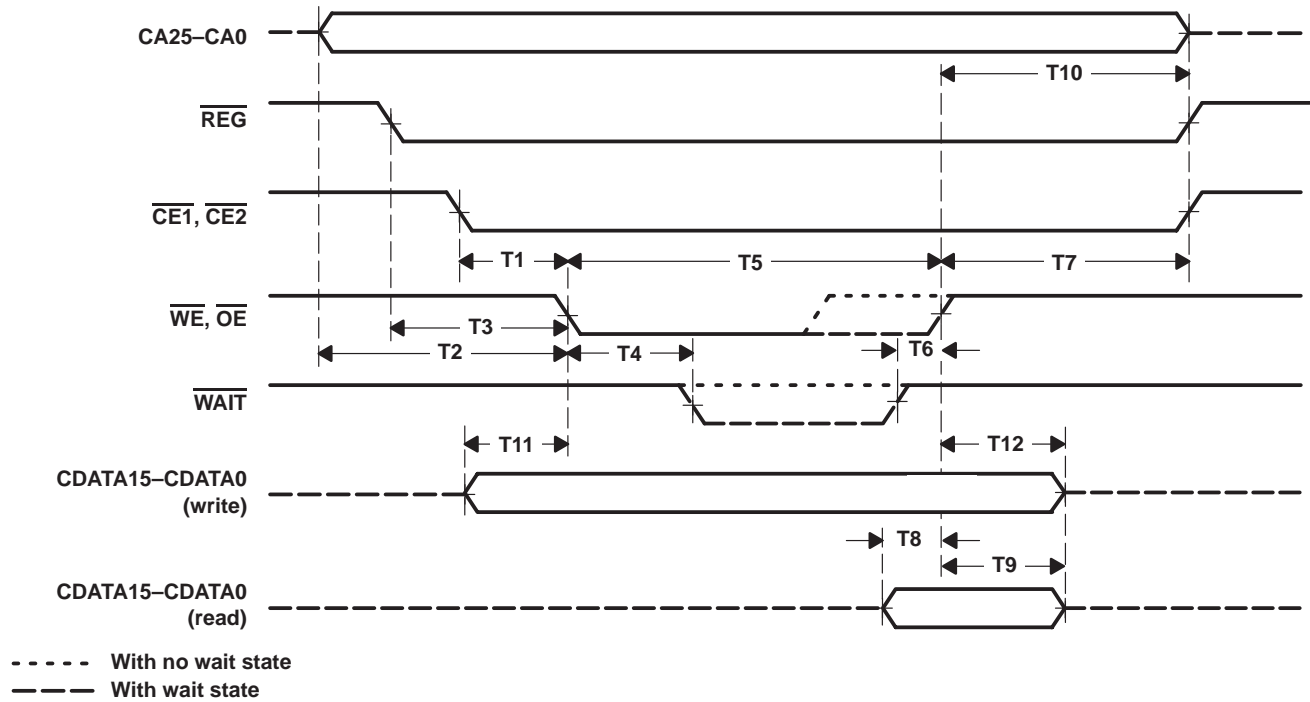

Figure 29. PC Card Memory Cycle

PC Card PARAMETER MEASUREMENT INFORMATION

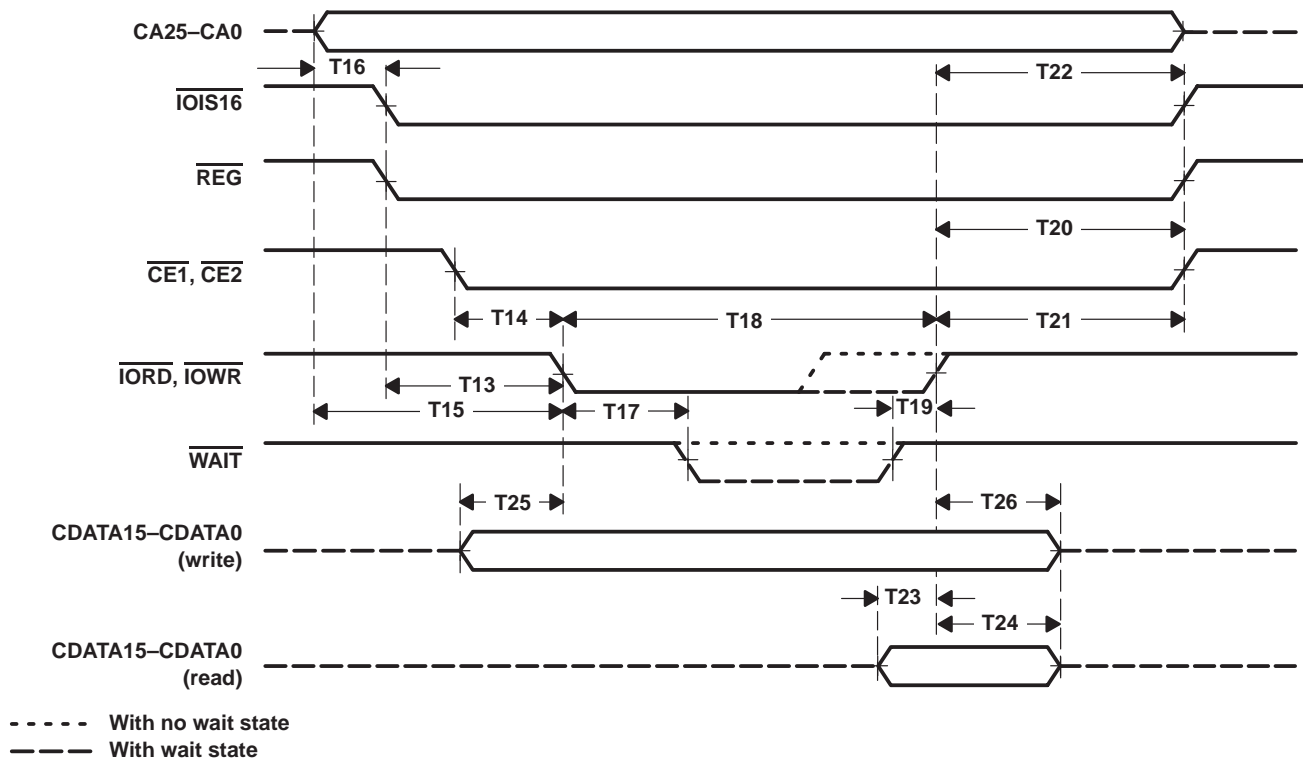

Figure 30. PC Card I/O Cycle

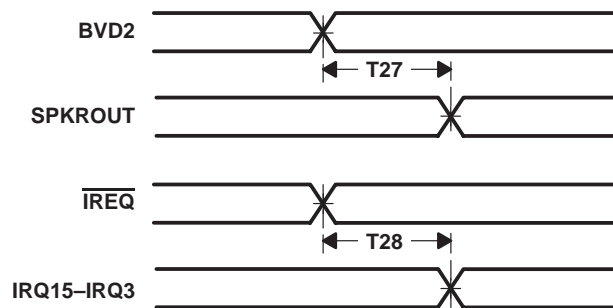
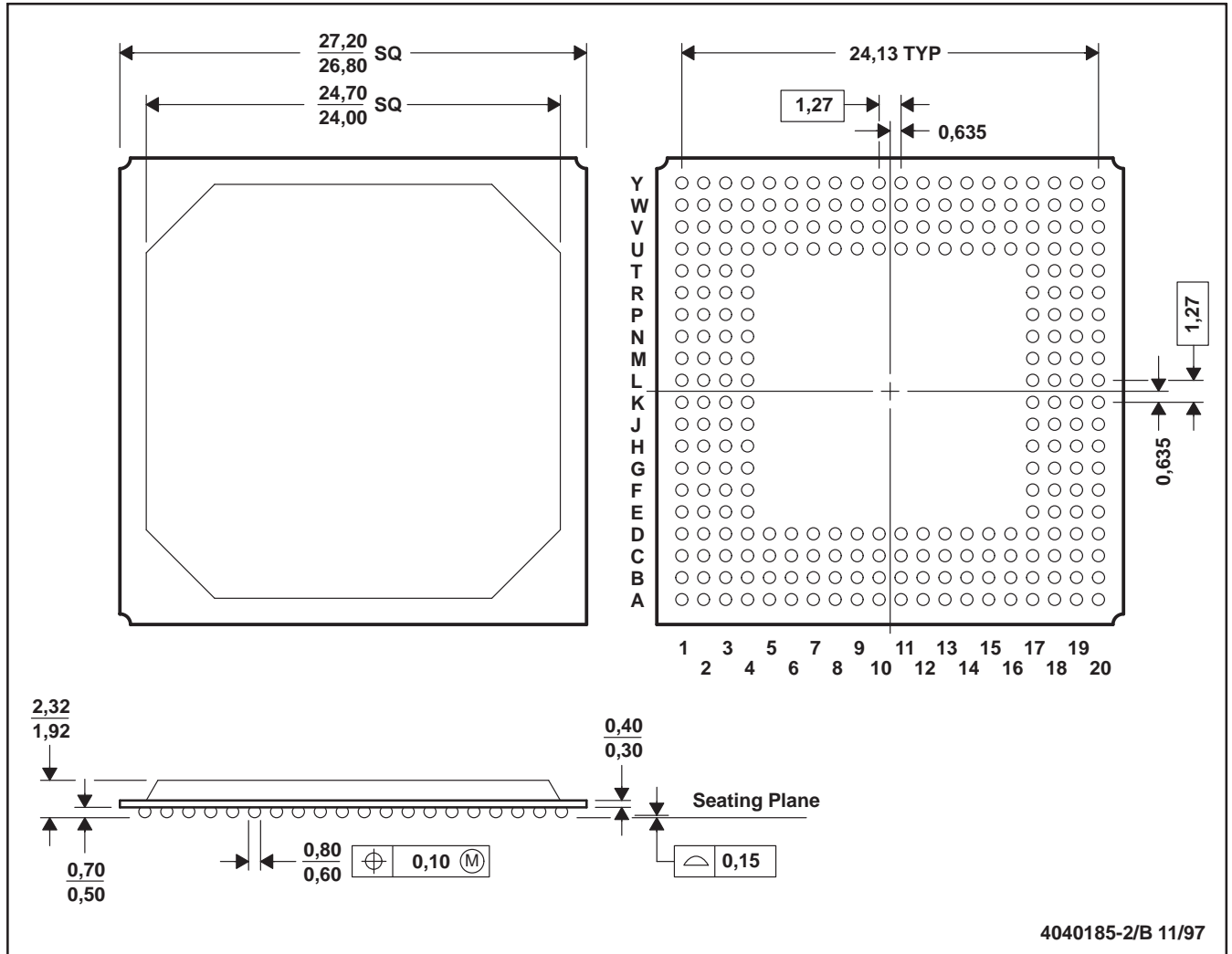

Figure 31. Miscellaneous PC Card Delay Times

MECHANICAL DATA

GFN (S-PBGA-N256)

PLASTIC BALL GRID ARRAY



- NOTES: A. All linear dimensions are in millimeters.  
B. This drawing is subject to change without notice.

# PCI4450 GFN/GJG PC Card and OHCI Controller

SCPS046 – JANUARY 1999

## MECHANICAL DATA

GJG (S-PBGA-N257)

PLASTIC BALL GRID ARRAY

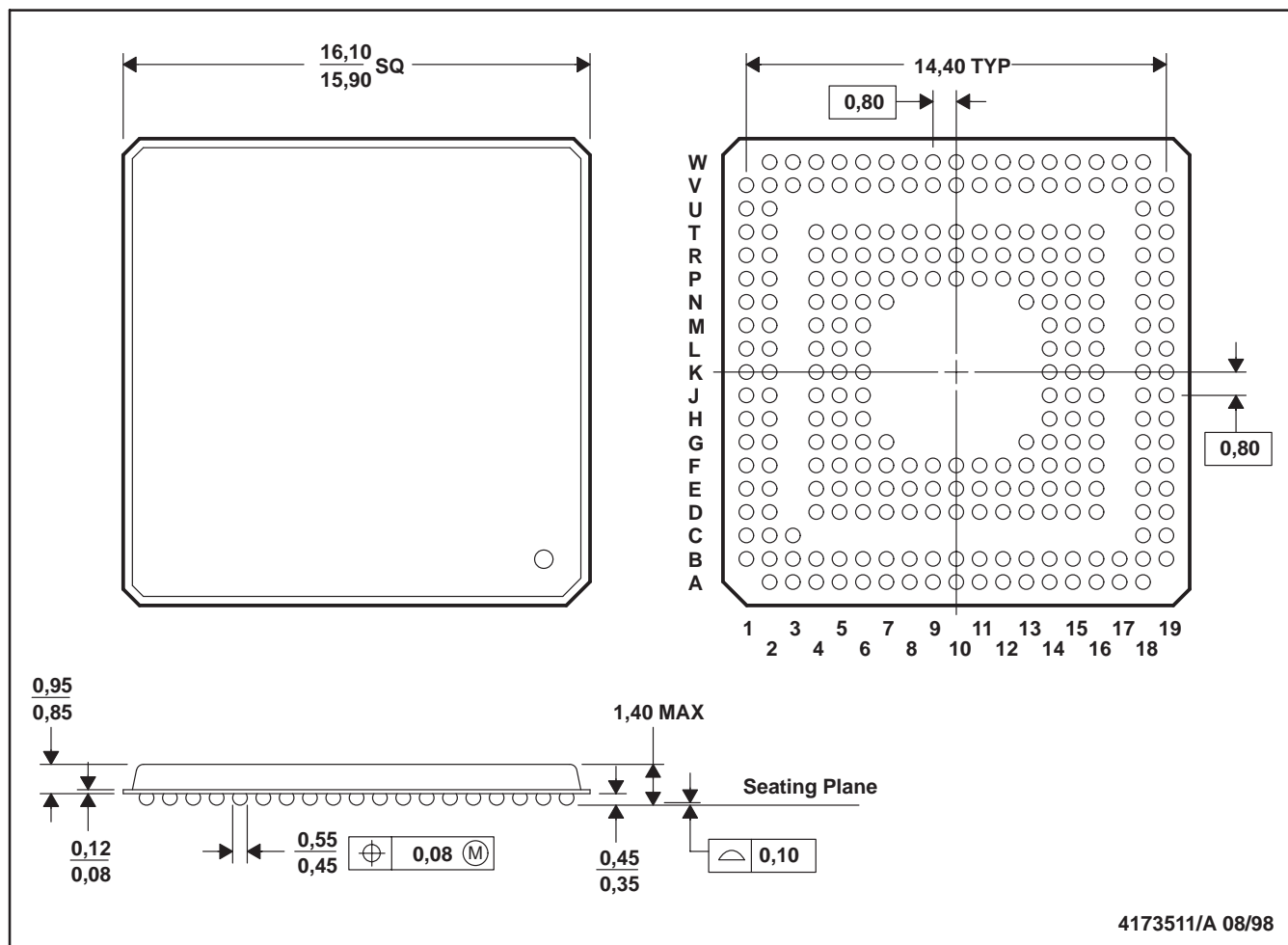

- NOTES: A. All linear dimensions are in millimeters.  
 B. This drawing is subject to change without notice.  
 C. MicroStar™ BGA configuration

Micro Star is a trademark of Texas Instruments Incorporated.



POST OFFICE BOX 655303 • DALLAS, TEXAS 75265

## IMPORTANT NOTICE

Texas Instruments and its subsidiaries (TI) reserve the right to make changes to their products or to discontinue any product or service without notice, and advise customers to obtain the latest version of relevant information to verify, before placing orders, that information being relied on is current and complete. All products are sold subject to the terms and conditions of sale supplied at the time of order acknowledgement, including those pertaining to warranty, patent infringement, and limitation of liability.

TI warrants performance of its semiconductor products to the specifications applicable at the time of sale in accordance with TI's standard warranty. Testing and other quality control techniques are utilized to the extent TI deems necessary to support this warranty. Specific testing of all parameters of each device is not necessarily performed, except those mandated by government requirements.

CERTAIN APPLICATIONS USING SEMICONDUCTOR PRODUCTS MAY INVOLVE POTENTIAL RISKS OF DEATH, PERSONAL INJURY, OR SEVERE PROPERTY OR ENVIRONMENTAL DAMAGE ("CRITICAL APPLICATIONS"). TI SEMICONDUCTOR PRODUCTS ARE NOT DESIGNED, AUTHORIZED, OR WARRANTED TO BE SUITABLE FOR USE IN LIFE-SUPPORT DEVICES OR SYSTEMS OR OTHER CRITICAL APPLICATIONS. INCLUSION OF TI PRODUCTS IN SUCH APPLICATIONS IS UNDERSTOOD TO BE FULLY AT THE CUSTOMER'S RISK.

In order to minimize risks associated with the customer's applications, adequate design and operating safeguards must be provided by the customer to minimize inherent or procedural hazards.

TI assumes no liability for applications assistance or customer product design. TI does not warrant or represent that any license, either express or implied, is granted under any patent right, copyright, mask work right, or other intellectual property right of TI covering or relating to any combination, machine, or process in which such semiconductor products or services might be or are used. TI's publication of information regarding any third party's products or services does not constitute TI's approval, warranty or endorsement thereof.