

THIS DOCUMENT IS THE PROPERTY OF KEYSTONE ELECTRONICS CORP. AND SHALL NOT BE REPRODUCED, DISTRIBUTED OR USED AS A BASIS FOR MANUFACTURE WITHOUT PRIOR WRITTEN PERMISSION FROM KEYSTONE ELECTRONICS CORP.

MOUNTING PAD LAYOUT REQUIRED FOR (2) 'AAAA' CLIPS

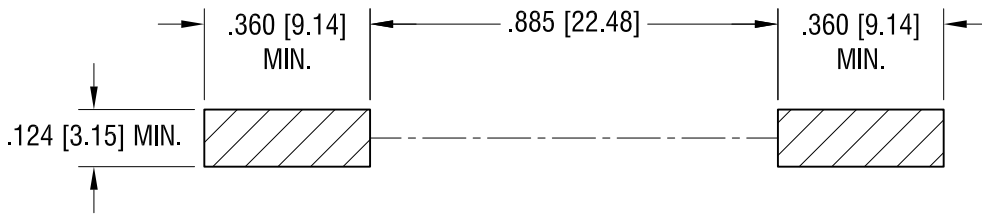

ACTUAL SIZE

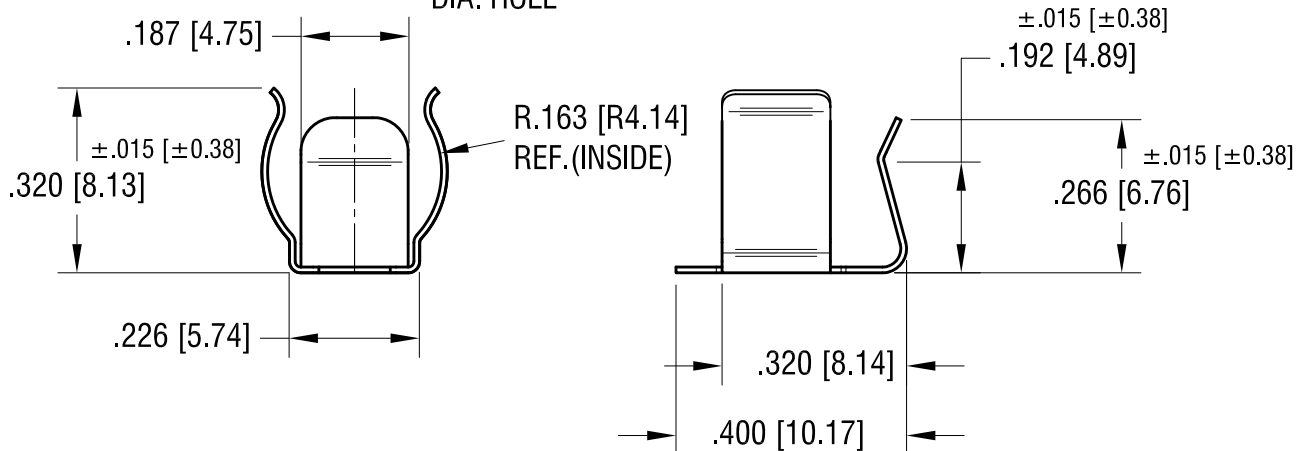
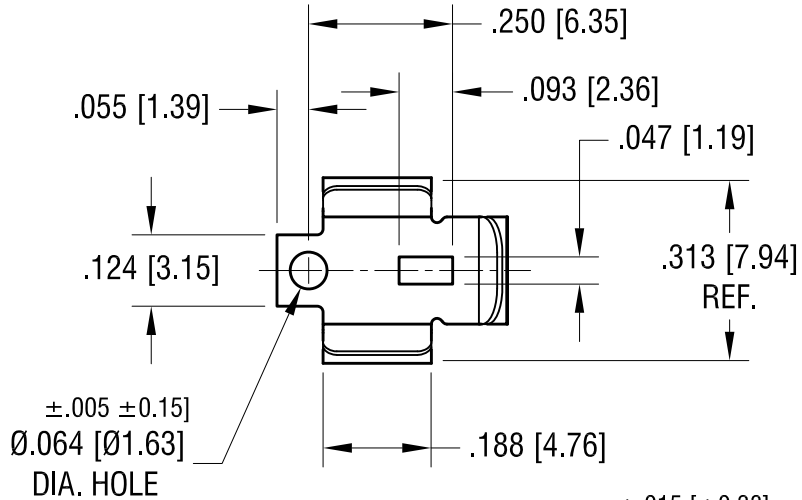

NOTE:

- HEAT TREAT TO SPRING TEMPER

**KEYSTONE ELECTRONICS CORP.**

www.keyelco.com • ASTORIA, N.Y. 11105-2017 • Tel (718) 956-8900

PART NAME

'AAAA' SMT BATTERY CLIP

MATERIAL

.010 [0.25] TH'K ANNEALED SPRING STEEL

FINISH

MATTE TIN PLATE

DRN BY

NT

DATE

7.20.09

APP'D

LN

SCALE

3X

TOLERANCES

INCH [MM]

DECIMAL

±.010 [±0.25]

ANGULAR

± 1°

UNLESS OTHERWISE SPECIFIED

CODE

C

DWG NO.

550

DATE	DESCRIPTION	REV.
10.28.16	CHANGE AS PER ECN16-074	C
4.11.16	CHANGE AS PER ECN16-047	B
1.30.13	CHANGE AS PER ECN 13-010	A