

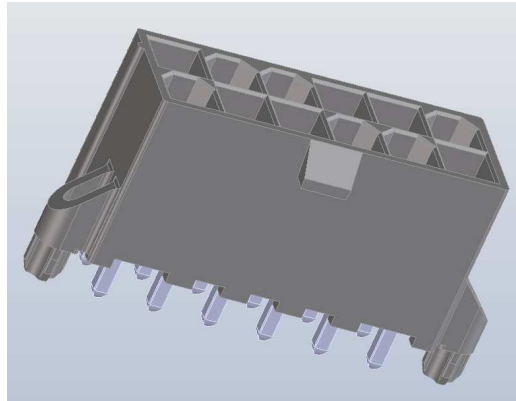

# PRODUCT SPECIFICATION

## 46207 MINI-FIT VERTICAL HI-TEMP HEADER



### TABLE OF CONTENTS

<u>Section</u>	<u>Page</u>
<b>1.0 SCOPE</b>	<b>2</b>
<b>2.0 PRODUCT DESCRIPTION</b>	<b>2</b>
2.1 Names and Series Numbers	2
Wire-To-Board	2
2.2 Dimensions, Materials, Platings, and Markings	2
2.3 Safety Agency Approvals	2
<b>3.0 APPLICABLE DOCUMENTS AND SPECIFICATIONS</b>	<b>2</b>
<b>4.0 RATINGS</b>	<b>2</b>
4.1 Voltage	2
4.2 Current Ratings	3
4.3 Temperature	3
4.4 Wave or SMT Solder Process Temperature	3
4.5 Durability	3
<b>5.0 WIRE-TO-BOARD PERFORMANCE</b>	<b>4</b>
5.1 Electrical Requirements	4
5.2 Mechanical Requirements	4
5.3 Environmental Requirements	5
<b>6.0 TEST SEQUENCES</b>	<b>6</b>
<b>7.0 PACKAGING</b>	<b>8</b>

REVISION: <b>A</b>	ECR/ECN INFORMATION: EC No: <b>UCP2010-2089</b> DATE: <b>02-17-2010</b>	TITLE: <b>PRODUCT SPECIFICATION FOR 46207 MINI-FIT RTC VERT. HEADER MATED TO PLUS HCS TERMINALS</b>	SHEET No. <b>1 of 8</b>
DOCUMENT NUMBER: <b>PS-46207-001</b>	CREATED / REVISED BY: <b>BWIRKUS</b>	CHECKED BY: <b>BWIRKUS</b>	APPROVED BY: <b>APATEL</b>



# PRODUCT SPECIFICATION

## 1.0 SCOPE

This Product Specification covers performance requirements for the 46207 Series MINI-FIT VERTICAL HI-TEMP HEADER 4.20 mm (.165 inch) centerline (pitch) printed circuit board (PCB) connector series with Tin plating when mated to MINI-FIT RECEPTACLE HOUSINGS using MINI-FIT PLUS HCS TERMINALS.

## 2.0 PRODUCT DESCRIPTION

### 2.1 NAMES AND SERIES NUMBER(S)

DESCRIPTION	SERIES NUMBER	RoHS	UL	CSA
Vertical Header	46207	Yes	Yes	Yes
Mating Female Crimp Terminal	45750	Yes	NA	NA
Receptacle Housing	5557	Yes	Yes	Yes

### 2.2 DIMENSIONS, MATERIALS, PLATINGS AND MARKINGS

Additional information on dimensions, materials, platings, markings, available part options and circuit sizes can be found on the applicable sales drawing (see Section 3.0).

### 2.3 SAFETY AGENCY APPROVALS

UL File: E29179  
CSA Certificate: LR19980

## 3.0 APPLICABLE DOCUMENTS AND SPECIFICATIONS

**46207** SALES DRAWING: SD-46207-001  
PACKAGING SPECIFICATIONS: PK-46207-001

**45750** SALES DRAWING: SD-45750-001  
PRODUCT SPECIFICATION: PS-45750-003

## 4.0 RATINGS

### 4.1 VOLTAGE

600 Volts AC (RMS) (or 600 Volts DC)

REVISION: <b>A</b>	ECR/ECN INFORMATION: EC No: <b>UCP2010-2089</b> DATE: <b>02-17-2010</b>	TITLE: <b>PRODUCT SPECIFICATION FOR 46207 MINI-FIT RTC VERT. HEADER MATED TO PLUS HCS TERMINALS</b>	SHEET No. <b>2 of 8</b>
DOCUMENT NUMBER: <b>PS-46207-001</b>	CREATED / REVISED BY: <b>BWIRKUS</b>	CHECKED BY: <b>BWIRKUS</b>	APPROVED BY: <b>APATEL</b>



# PRODUCT SPECIFICATION

## 4.2 MAXIMUM CURRENT RATING (Amperes) \*\*

46207 HEADERS MATED TO 45750 PLUS HCS TERMINALS				
45750 CRIMPED WIRE SIZE	CIRCUIT SIZE			
	4-6*	8,10,12	14,16,18	20,22,24
AWG #16	12.0	10.5	10.0	9.5
AWG #18	10.0	8.0	8.0	8.0
AWG #20	8.0	7.5	7.0	7.0

\* A 4-circuit if used with only 2 circuits loaded is rated at 13A, 11A and 9.5A respectively for 16, 18 and 20 AWG wire.

\*\* Ratings shown in table are derived from Temperature Rise testing (see Table 5.1) and based on configurations in which all circuits are fully loaded, running at the rated current, and using the designated tinned copper conductor stranded wire. Current rating is application dependent and the ratings shown are intended as a guideline. Appropriate de-rating is required depending on factors such as higher ambient conditions, copper weight of PCB traces, gross heating from adjacent modules/components and other factors that influence connector performance.

## 4.3 TEMPERATURE

Operating temperature (including T-rise from applied current) is application dependent. Mini-Fit Series 46207 series headers when used with 45750 Plus HCS terminals have a Temperature Life Rating of 65°C Field Temperature and Field Life of 10 years based on testing per EIA-364-17B, Method A. See test sequences in this Product Specification for details on test temperature and exposure time.

## 4.4 WAVE OR SMT SOLDER PROCESS TEMPERATURE

265°C MAX

## 4.5 DURABILITY (MATING CYCLES)

Tin: 100 cycles

REVISION: <b>A</b>	ECR/ECN INFORMATION: EC No: UCP2010-2089 DATE: 02-17-2010	TITLE: <b>PRODUCT SPECIFICATION FOR 46207 MINI-FIT RTC VERT. HEADER MATED TO PLUS HCS TERMINALS</b>	SHEET No. <b>3 of 8</b>
DOCUMENT NUMBER: <b>PS-46207-001</b>	CREATED / REVISED BY: <b>BWIRKUS</b>	CHECKED BY: <b>BWIRKUS</b>	APPROVED BY: <b>APATEL</b>



# PRODUCT SPECIFICATION

## 5.0 WIRE-TO-BOARD PERFORMANCE

The following performance requirements pertain to the 46207 series header or the header's performance when mated to Mini-Fit receptacle housings having 45750 series Plus HCS terminals.

5.1 ELECTRICAL REQUIREMENTS			
ITEM	DESCRIPTION	TEST CONDITION	REQUIREMENT
1	<b>Contact Resistance (Low Level)</b>	Mate connectors. Apply a maximum voltage of 20 mV and a current of 100 mA. Wire resistance shall be removed from the measured value.	10 milliohms MAXIMUM [initial]
2	<b>Insulation Resistance</b>	Mate connectors. Apply a voltage of 500 VDC between adjacent terminals and between terminals to ground.	1000 Megohms MINIMUM
3	<b>Dielectric Withstanding Voltage</b>	Mate connectors. Apply a voltage of 2200 VAC for 1 minute between adjacent terminals and between terminals to ground.	No breakdown. Current leakage < 5 mA
4	<b>Temperature Rise (via Current Cycling)</b>	Mate connectors. Measure the temperature rise at the rated current after 96 hours, during current cycling (45 minutes ON and 15 minutes OFF per hour) for 240 hours, and after final 96-hour steady state.	Temperature rise: +30°C MAXIMUM

5.2 MECHANICAL REQUIREMENTS			
ITEM	DESCRIPTION	TEST CONDITION	REQUIREMENT
1	<b>Mate and Unmate Forces Per Circuit</b>	Mate and unmate individual terminals (male to female) at a rate of 25 ± 6 mm (1 ± ¼ inch) per minute for 5 mating cycles.	11.1 N (2.5 lbf) MAX. insertion force; 2.2 N (0.5 lbf) MIN. withdrawal force
2	<b>Pin Retention Force (from Housing – PC tail side)</b>	Axial pushout force exerted on the PC tail side of pin in header at a rate of 25 ± 6 mm (1 ± ¼ inch) per minute.	6.67 N (1.50 lbf) MINIMUM retention force per pin
3	<b>Pin Retention Force (from Housing – Pin mating side)</b>	Axial pushout force exerted on mating side of pin in header at a rate of 25 ± 6 mm (1 ± ¼ inch) per minute.	89.0 N (20.0 lbf) MINIMUM retention force per pin
4a	<b>Durability</b>	Mate connectors up to 100 cycles at a maximum rate of 10 cycles per minute. (Test Group 7 only).	20 milliohms MAXIMUM
4b	<b>Durability (preconditioning)</b>	Mate connectors for 20 cycles at a maximum rate of 10 cycles per minute prior to Environmental Tests (Test Groups 1-5).	Visual: no damage

REVISION: <b>A</b>	ECR/ECN INFORMATION: EC No: UCP2010-2089 DATE: 02-17-2010	TITLE: <b>PRODUCT SPECIFICATION FOR 46207 MINI-FIT RTC VERT. HEADER MATED TO PLUS HCS TERMINALS</b>	SHEET No. <b>4 of 8</b>
DOCUMENT NUMBER: <b>PS-46207-001</b>	CREATED / REVISED BY: <b>BWIRKUS</b>	CHECKED BY: <b>BWIRKUS</b>	APPROVED BY: <b>APATEL</b>



# PRODUCT SPECIFICATION

## 5.2 MECHANICAL REQUIREMENTS (continued)

ITEM	DESCRIPTION	TEST CONDITION	REQUIREMENT
5	Vibration (Random)	Mate connectors and vibrate per EIA 364-28, test condition VII.	10 milliohms MAXIMUM (change from initial) Discontinuity < 1 microsecond
6	PCB Peg Engagement and Separation Forces (Header to PCB)	Engage and separate header at a rate of 25 ± 6 mm (1 ± ¼ inch) per minute. (Applies to parts with PCB retention features only)	55.0 N (12.4 lbf) MAXIMUM insertion force; 10.0 N (2.2 lbf) MINIMUM withdrawal force
7	Thumbblatch Yield Strength	Mate loaded connectors fully. Pull connectors apart at a rate of 25 ± 6mm (1 ± ¼ inch) per minute.	68 n (15.29 lbf) Min.

## 5.3 ENVIRONMENTAL REQUIREMENTS

ITEM	DESCRIPTION	TEST CONDITION	REQUIREMENT
1	Thermal Shock	Mate connectors. Expose for 5 cycles between temperatures -55 and 105° C and for 0.5 hours dwell at each temperature.	20 milliohms MAXIMUM Visual: No Damage Dielectric Strength per 5.1.5 Insulation Resistance per 5.1.4
2	Thermal Aging	Mate connectors. Expose to 96 hours at 105 ± 2°C.	20 milliohms MAXIMUM; Visual: No Damage
3	Humidity (Steady State)	Mate connectors. Expose to a temperature of 60 ± 2°C with a relative humidity of 90-95% for 96 hours.	20 milliohms MAXIMUM Dielectric Strength per 5.1.5 Insulation Resistance per 5.1.4 Visual: No Damage
4	Solderability	Per SMES-152	Solder coverage: 95% MINIMUM (per SMES-152)
5	Solder Temperature Heat Transfer Resistance	Dip header tail terminals to wave solder process. Solder Duration: 5 ± 0.5 seconds; Solder Temperature: 260 ± 5°C	Visual: No Damage to the area where the pin locks to the header housing
6	Moisture Sensitivity	Per JEDEC J-STD-020, Moisture Sensitivity Level 1. Expose headers to 85°C humidity for 168 hours. Following this, parts are to be run through a convection oven for 3 exposures with reflow profile having a peak temperature of 260°C.	Visual: No evidence of blistering
7	Mixed Flowing Gas	(Gold plated only) Class IIA Gas concentrations per ES-364-65A	20 milliohms MAXIMUM Visual: No Damage

REVISION: <b>A</b>	ECR/ECN INFORMATION: <b>EC No: UCP2010-2089</b> <b>DATE: 02-17-2010</b>	TITLE: <b>PRODUCT SPECIFICATION FOR 46207 MINI-FIT RTC VERT. HEADER MATED TO PLUS HCS TERMINALS</b>	SHEET No. <b>5 of 8</b>
DOCUMENT NUMBER: <b>PS-46207-001</b>	CREATED / REVISED BY: <b>BWIRKUS</b>	CHECKED BY: <b>BWIRKUS</b>	APPROVED BY: <b>APATEL</b>



# PRODUCT SPECIFICATION

## 6.0 TEST SEQUENCES

Testing sequences to be performed in accordance with EIA-364-1000.01

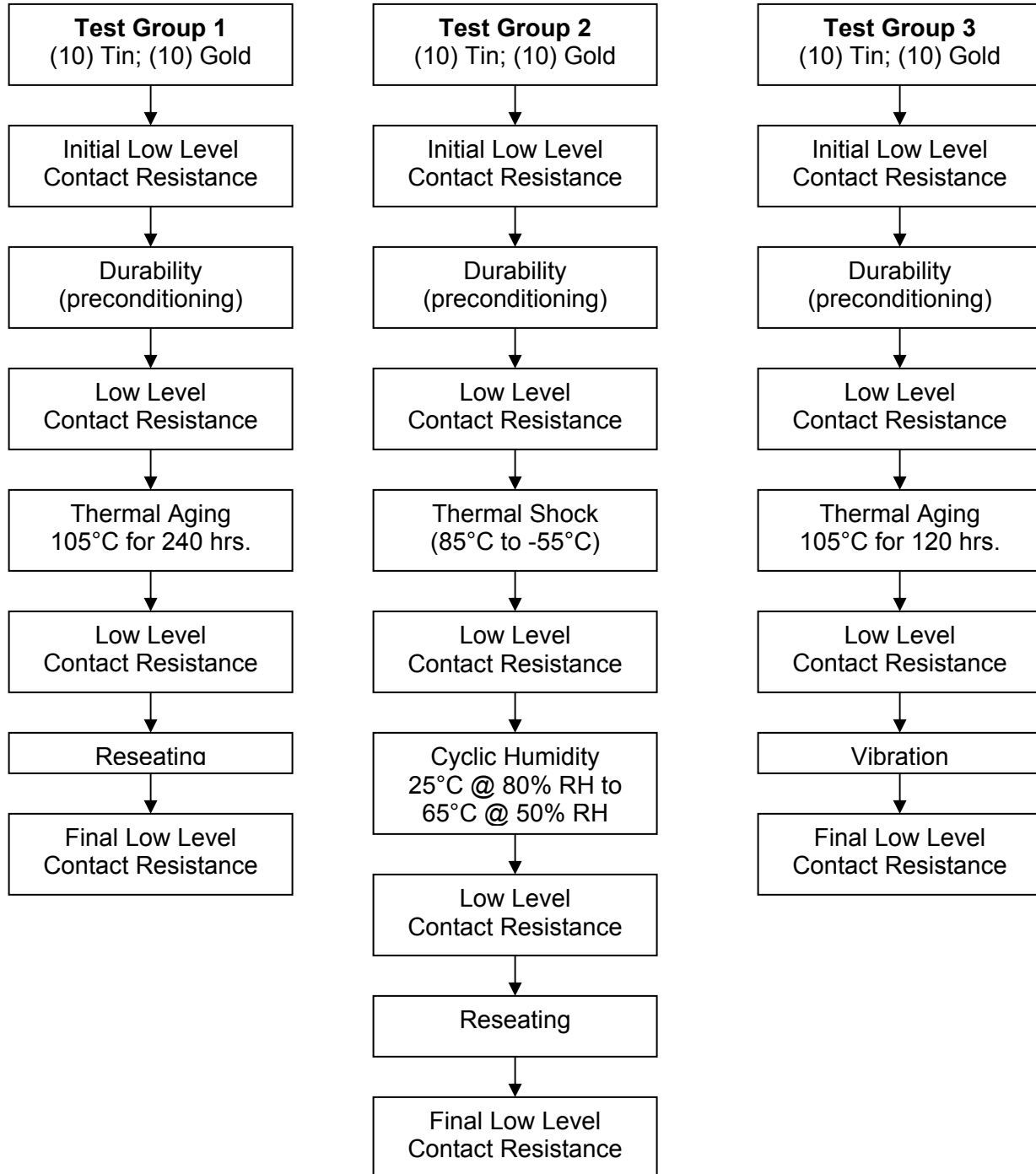

REVISION: <b>A</b>	ECR/ECN INFORMATION: EC No: <b>UCP2010-2089</b> DATE: <b>02-17-2010</b>	TITLE: <b>PRODUCT SPECIFICATION FOR 46207 MINI-FIT RTC VERT. HEADER MATED TO PLUS HCS TERMINALS</b>	SHEET No. <b>6 of 8</b>
DOCUMENT NUMBER: <b>PS-46207-001</b>	CREATED / REVISED BY: <b>BWIRKUS</b>	CHECKED BY: <b>BWIRKUS</b>	APPROVED BY: <b>APATEL</b>



# PRODUCT SPECIFICATION

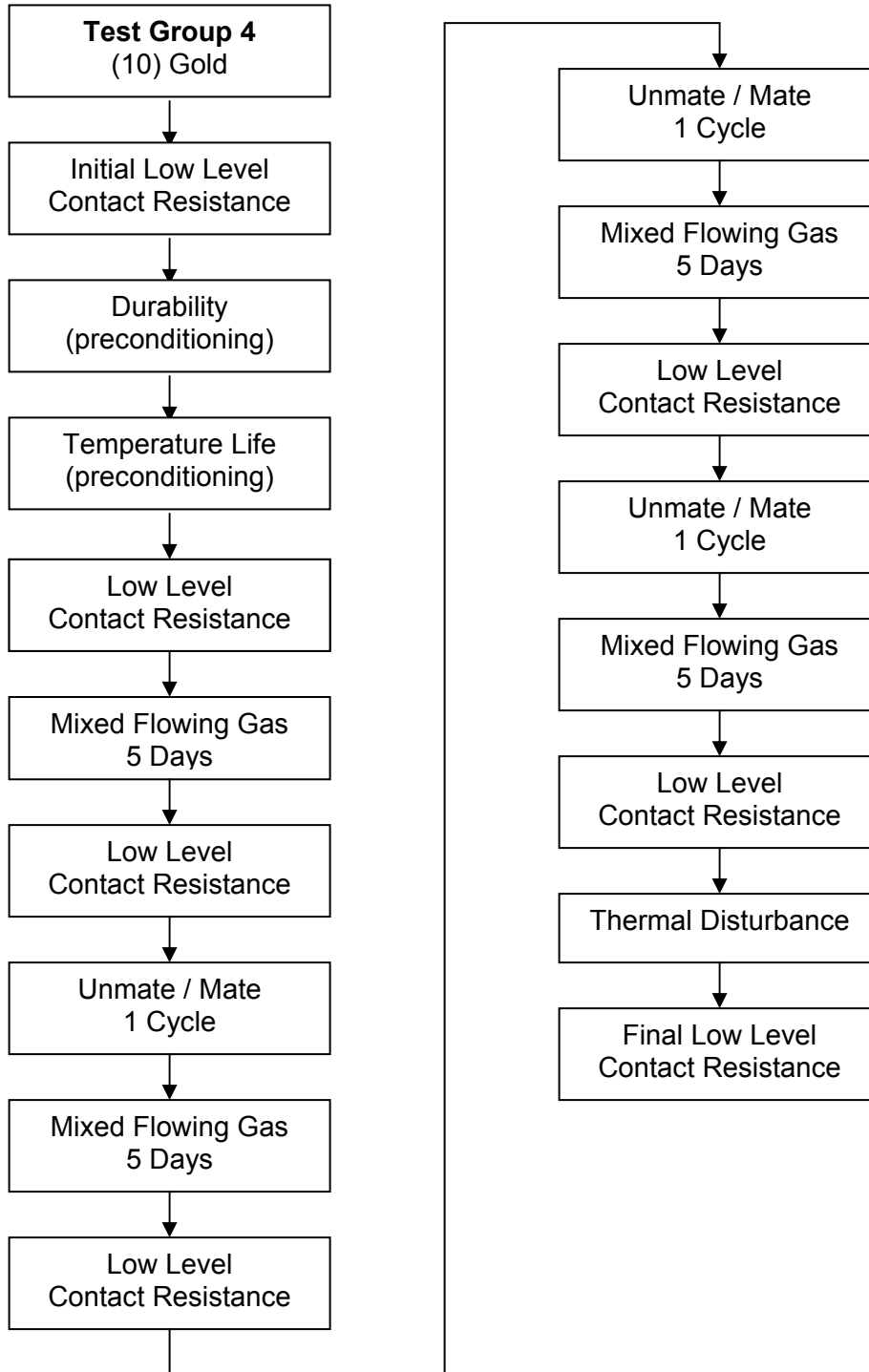

REVISION: <b>A</b>	ECR/ECN INFORMATION: EC No: <b>UCP2010-2089</b> DATE: <b>02-17-2010</b>	TITLE: <b>PRODUCT SPECIFICATION FOR 46207 MINI-FIT RTC VERT. HEADER MATED TO PLUS HCS TERMINALS</b>	SHEET No. <b>7 of 8</b>
DOCUMENT NUMBER: <b>PS-46207-001</b>	CREATED / REVISED BY: <b>BWIRKUS</b>	CHECKED BY: <b>BWIRKUS</b>	APPROVED BY: <b>APATEL</b>



# PRODUCT SPECIFICATION

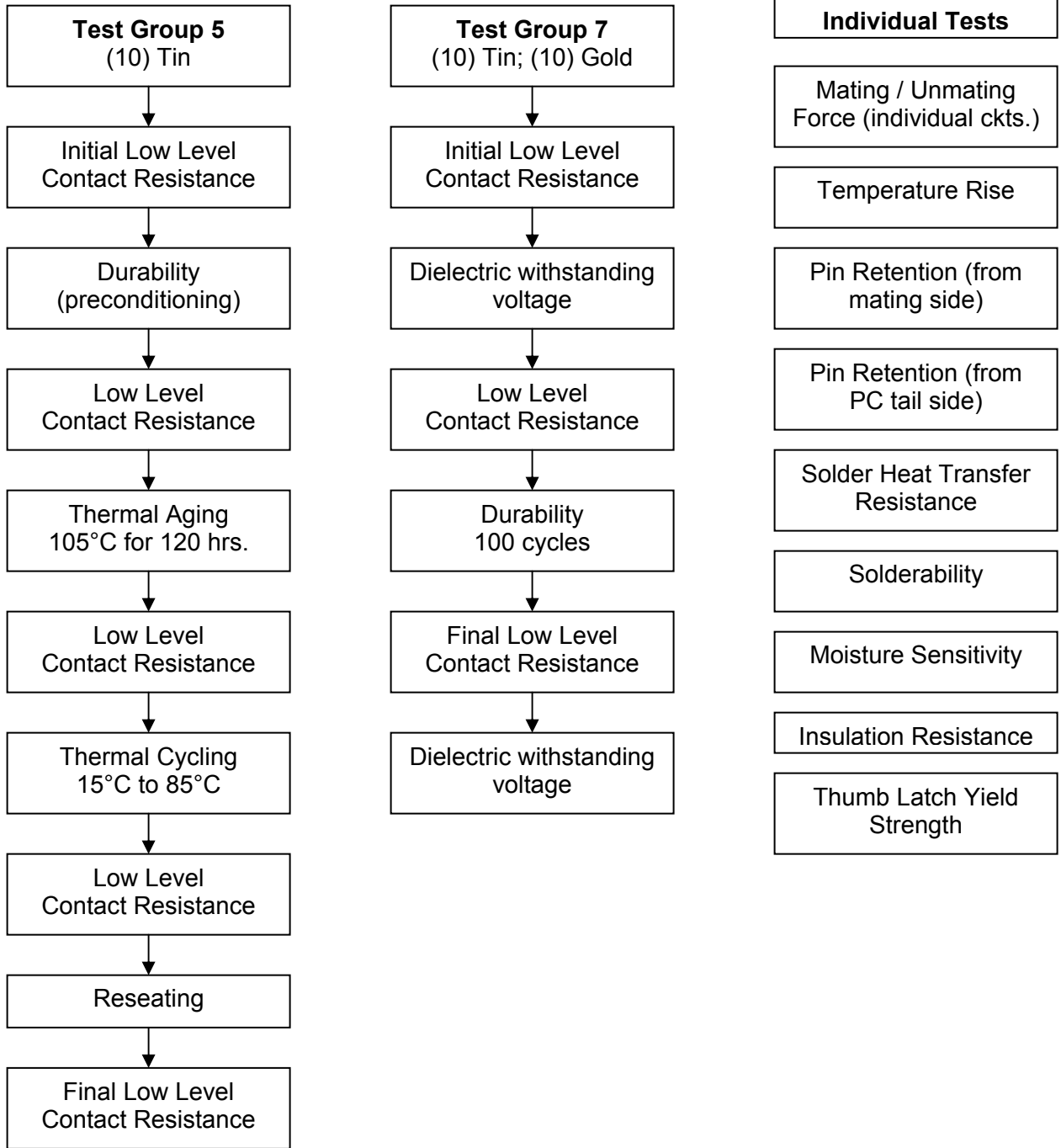

## 7.0 PACKAGING

Parts shall be packaged to protect against damage during normal handling, transit and storage. Refer to appropriate Packaging Specification for details regarding packaging.

REVISION: <b>A</b>	ECR/ECN INFORMATION: EC No: <b>UCP2010-2089</b> DATE: <b>02-17-2010</b>	TITLE: <b>PRODUCT SPECIFICATION FOR 46207 MINI-FIT RTC VERT. HEADER MATED TO PLUS HCS TERMINALS</b>	SHEET No. <b>8 of 8</b>
DOCUMENT NUMBER: <b>PS-46207-001</b>	CREATED / REVISED BY: <b>BWIRKUS</b>	CHECKED BY: <b>BWIRKUS</b>	APPROVED BY: <b>APATEL</b>