

10 9 8 7 6 5 4 3 2 1

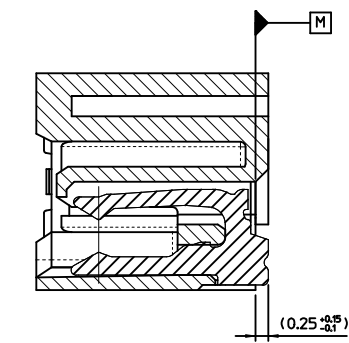
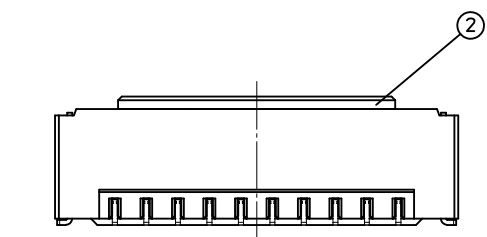
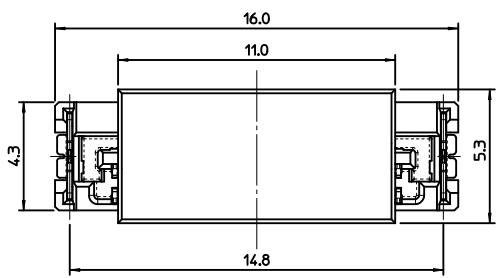
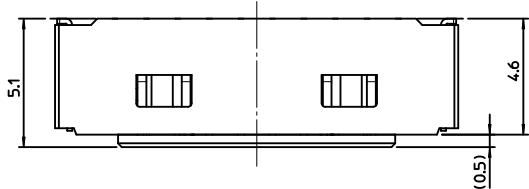

SECTION A-A (SCALE 10:1)

**<PART LIST>**

| NO. | PART NAME        |
|-----|------------------|
| ①   | HEADER           |
| ②   | PICK-UP COVER    |
| ③   | CONTACT TERMINAL |
| ④   | FITTING NAIL     |

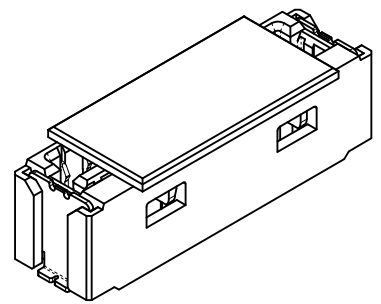
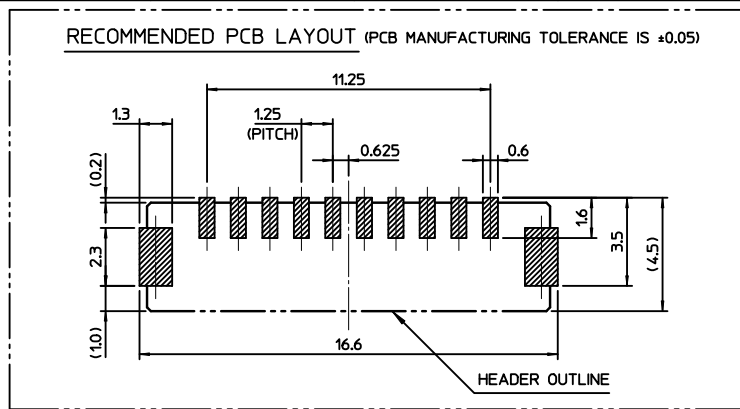

ISOMETRIC VIEW

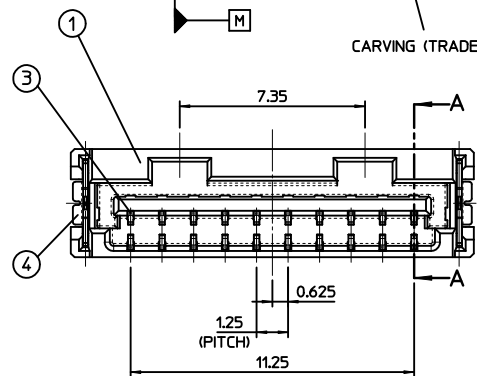
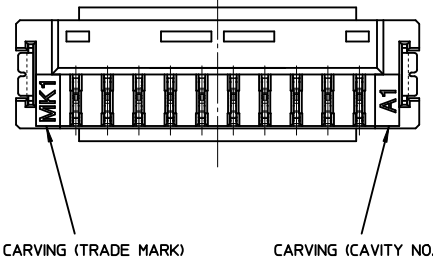
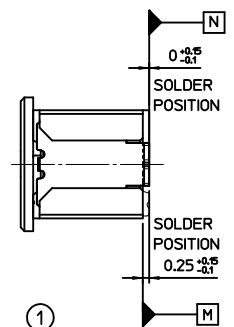

PICK-UP COVER OPENED

**NOTE**

- MATED WITH : 104105-1000
- MATERIAL
  - HEADER : THERMOPLASTIC, HALOGEN FREE UL94V-0, COLOR OF NATURAL
  - PICK-UP COVER : THERMOPLASTIC, UL94V-0, COLOR OF NATURAL
  - CONTACT TERMINAL : COPPER ALLOY (t=0.2)
  - FITTING NAIL : COPPER ALLOY (t=0.2)
- FINISHES
  - CONTACT TERMINAL : PURE-TIN PLATING ON OVERALL. THICKNESS 3.0µm~5.0µm UNDER PLATING Ni OVERALL. THICKNESS 1.25µm~3.75µm
  - FITTING NAIL : PURE-TIN PLATING ON OVERALL. THICKNESS 3.0µm~5.0µm UNDER PLATING Ni OVERALL. THICKNESS 1.25µm~3.75µm
- COPLANALITY OF SOLDER TAILS (PEAK TEMP. : 260°C),
  - BEFORE REFLOW : 0.08 MAX.
  - AFTER REFLOW : 0.1 MAX.
- PRODUCT SPECIFICATION : PS-104099-001
- PACKING INFORMATION : PK-104099-001

<TABLE>

|   |                        |                               |  |
|---|------------------------|-------------------------------|--|
| 1040991017                                      |                        | NATURAL                       |  |
| ORDER NO.                                       |                        | COLOR                         |  |
| SCALE<br>5:1                                    | DESIGN UNITS<br>METRIC | THIRD ANGLE PROJECTION        |  |
| TITLE<br>1.25 W/B ST. CONN. 10P<br>HEADER ASS'Y |                        |                               |  |
| DRAWN BY<br>HTSONG                              |                        | DATE<br>2010/06/28            |  |
| CHECKED BY<br>SHCHU                             |                        | DATE<br>2010/06/28            |  |
| APPROVED BY<br>YSKIM                            |                        | DATE<br>2010/06/28            |  |
| MATERIAL NO.<br>1040991017                      |                        | DOCUMENT NO.<br>SD-104099-001 |  |
| SIZE<br>A3                                      |                        | SHEET NO.<br>1 OF 1           |  |

**RELEASED**  
 EC NO: KOR2011-0072  
 DRWN:HTSONG 2011/01/10  
 CHKD:SHCHU 2011/01/10  
 APPR:YUNSIKKIM 2011/01/10

| REV | DESCRIPTION |
|-----|-------------|
| A   |             |

**QUALITY SYMBOLS**

▽=0  
 ◁=0

|               | GENERAL TOLERANCES (UNLESS SPECIFIED) |       |
|---------------|---------------------------------------|-------|
|               | mm                                    | INCH  |
| 4 PLACES      | ± ---                                 | ± --- |
| 3 PLACES      | ± ---                                 | ± --- |
| 2 PLACES      | ± 0.25                                | ± --- |
| 1 PLACE       | ± 0.25                                | ± --- |
| ANGULAR ± 1 ° |                                       |       |

DRAFT WHERE APPLICABLE  
MUST REMAIN  
WITHIN DIMENSIONS

**DIMENSION STYLE**  
MM ONLY

DRAWN BY: HTSONG  
 DATE: 2010/06/28

CHECKED BY: SHCHU  
 DATE: 2010/06/28

APPROVED BY: YSKIM  
 DATE: 2010/06/28

MATERIAL NO.: 1040991017

9 8 7 6 5 4 3 2 1

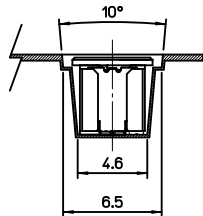
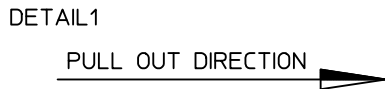
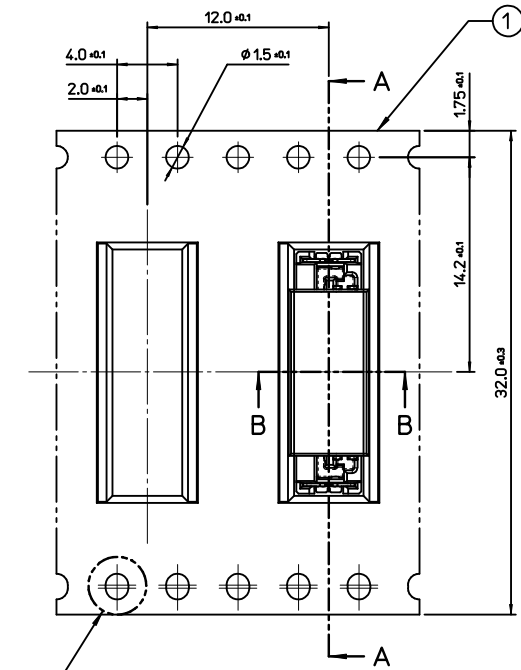

SECTION B-B

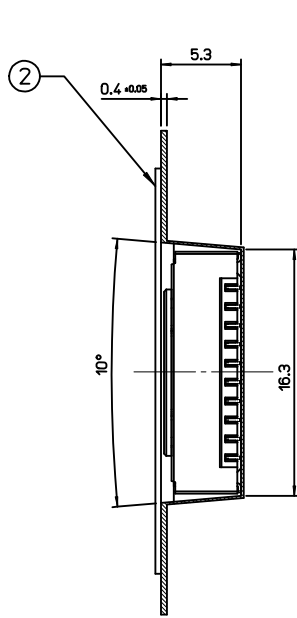

SECTION A-A

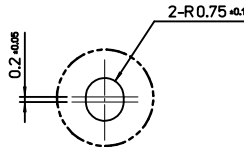

DETAIL 1 (SCALE 5:1)

NOTE  
1. QUANTITY OF CONNECTORS : 1,300 PCS/REEL

2. LEAD LENGTH

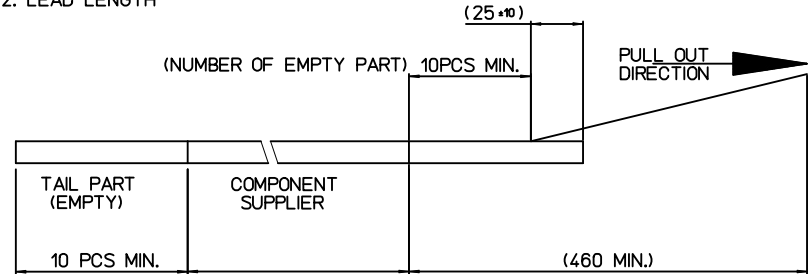

3. PEELING OFF FORCE OF COVER TAPE : 0.1N~0.59N(10.2GF~60GF)  
(PEELING DIRECTION AS SHOW IN FOLLOW FIG.)  
PEELING OFF SPEED : 300mm/Min.(Ref.)

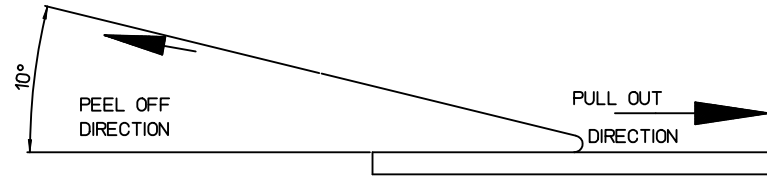

4. FLASH IN ANY PORTION SHOULD BE LESS THAN 0.20mm MAX.  
5. UNLESS OTHERWISE SPECIFIED INNER R0.2 MAX  
6. DRAFT ANGLE 3°MAX

<TABLE>

|              |             |            |             |
|--------------|-------------|------------|-------------|
| 104099-1017  | 104099-1017 | 32.0mm     | 104099-9001 |
| MATERIAL NO. | CONNECTOR   | TAPE WIDTH | EMBOSS TAPE |

|     |                       |                |        |
|-----|-----------------------|----------------|--------|
| ③   | PLASTIC BOBBIN        | HI P.S         | WHITE  |
| ②   | COVER TAPE            | PET ANTISTATIC | 26.0mm |
| ①   | CARRIER (EMBOSS) TAPE | PET ANTISTATIC |        |
| NO. | DESCRIPTION           | MATERIAL       | REMARK |

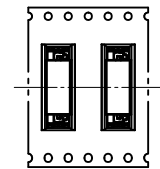

PULL OUT DIRECTION

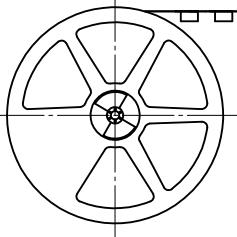

PLASTIC BOBBIN

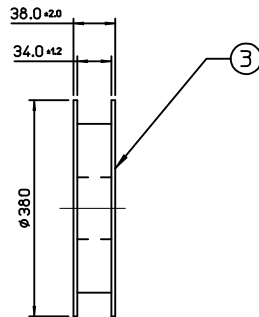

|                 |                     |            |            |
|-----------------|---------------------|------------|------------|
| RELEASED        | EC NO: KOR2011-0072 | 2011/01/10 | 2011/01/10 |
| DRWN: HTSONG    | CHKD: SHCHU         | 2011/01/10 | 2011/01/10 |
| APPR: YUNSIKKIM |                     |            |            |
| DESCRIPTION     |                     |            |            |
| QUALITY SYMBOLS | ▽=0                 | ∇=0        |            |
| REV             | A                   |            |            |

GENERAL TOLERANCES (UNLESS SPECIFIED)

|               |        |       |
|---------------|--------|-------|
|               | mm     | INCH  |
| 4 PLACES      | ± ---  | ± --- |
| 3 PLACES      | ± ---  | ± --- |
| 2 PLACES      | ± 0.25 | ± --- |
| 1 PLACE       | ± 0.25 | ± --- |
| ANGULAR ± 3 ° |        |       |

DIMENSION STYLE  
MM ONLY

|              |               |  |
|--------------|---------------|--|
| DRAWN BY     | DATE          | TITLE                                    |
| HTSONG       | 2010/06/28    | 1.25 W/B ST. CONN. 10P<br>EMBOSS PACKAGE |
| CHECKED BY   | DATE          |  |
| SHCHU        | 2010/06/28    |  |
| APPROVED BY  | DATE          |  |
| YSKIM        | 2010/06/28    |  |
| MATERIAL NO. | DOCUMENT NO.  |  |
| SEE TABLE    | SD-104099-002 |  |

SCALE  
3:1

DESIGN UNITS  
METRIC

THIRD ANGLE PROJECTION

DRAFT WHERE APPLICABLE  
MUST REMAIN  
WITHIN DIMENSIONS

SIZE  
A3

MOLEX INCORPORATED

SD-104099-002

1 OF 1

THIS DRAWING CONTAINS INFORMATION THAT IS PROPRIETARY TO MOLEX INCORPORATED AND SHOULD NOT BE USED WITHOUT WRITTEN PERMISSION