

QSFP-40G-PDAC3M-C

MSA and TAA Compliant 40GBase-CU QSFP+ Direct Attach Cable (Passive Twinax, 3m)

Features

- Full duplex 4 channel parallel passive optical cable
- Transmission data rate up to 10.3Gbit/s per channel
- SFF-8436 QSFP+ compliant
- Hot pluggable electrical interface
- Low power consumption
- 30 AWG Wire Gauge
- Housing isolated from connector ground
- Operating case temperature 0°C to +70°C
- 3.3V power supply voltage
- RoHS 6 compliant



Product Description

This is an MSA compliant 40GBase-CU QSFP+ to QSFP+ direct attach cable that operates over passive copper with a maximum reach of 3.0m (9.8ft). It has been programmed, uniquely serialized, and data-traffic and application tested to ensure it is 100% compliant and functional. This direct attach cable is TAA (Trade Agreements Act) compliant, and is built to comply with MSA (Multi-Source Agreement) standards. We stand behind the quality of our products and proudly offer a limited lifetime warranty.

Prolabs' direct attach cables are RoHS compliant and lead free.

TAA refers to the Trade Agreements Act (19 U.S.C. & 2501-2581), which is intended to foster fair and open international trade. TAA requires that the U.S. Government may acquire only "U.S. – made or designated country end products."



Specifications

Parameter	Specifications	Unit
Min. Dielectric Withstand Voltage	300	VDC
Insulation Resistance	1000	Mohms
Current Rating	0.5 Amp Min/Signal Contact	
Operating Temperature	0 to 70	°C
Flammability Rating (Plastics)	UL 94	
Shield	Braid/Foil	
Connector		
Back shell Material	Nickel Plated Zinc Diecast	
Contact Material	PCB with Gold-Plated Pads	
Max. Insertion Force	40	N
Max. Withdrawal Force	30	N
Durability	250	Cycles
Tightest Recommended Vertical Spacing (Belly to Belly)	11.80	mm
Tightest Recommended Vertical Spacing (Stacked)	17.50	mm
Cable		
Conductor	Solid	
Wire Gauge	28	AWG
Impedance	100±5	ohms
Construction	Twinaxial	
Jacket Type	PVC	

Mechanical Specifications

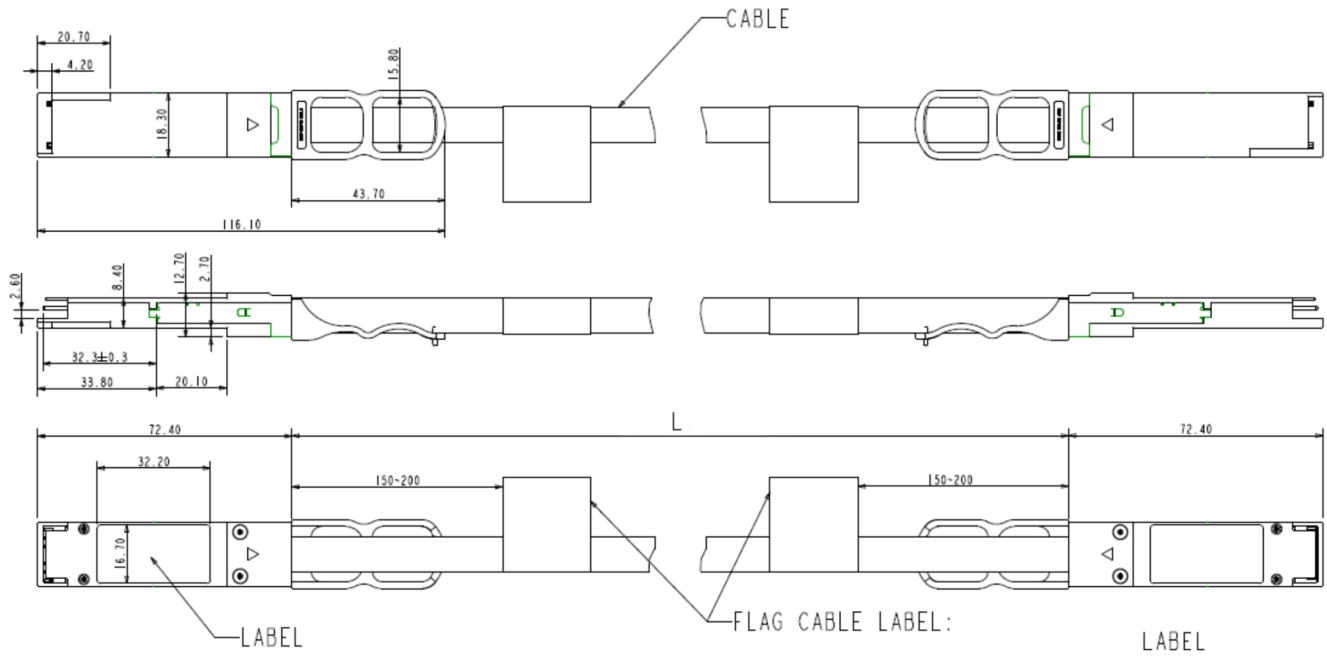

About ProLabs

Our experience comes as standard; for over 15 years ProLabs has delivered optical connectivity solutions that give our customers freedom and choice through our ability to provide seamless interoperability. At the heart of our company is the ability to provide state-of-the-art optical transport and connectivity solutions that are compatible with over 90 optical switching and transport platforms.

Complete Portfolio of Network Solutions

ProLabs is focused on innovations in optical transport and connectivity. The combination of our knowledge of optics and networking equipment enables ProLabs to be your single source for optical transport and connectivity solutions from 100Mb to 400G while providing innovative solutions that increase network efficiency. We provide the optical connectivity expertise that is compatible with and enhances your switching and transport equipment.

Trusted Partner

Customer service is our number one value. ProLabs has invested in people, labs and manufacturing capacity to ensure that you get immediate answers to your questions and compatible product when needed. With Engineering and Manufacturing offices in the U.K. and U.S. augmented by field offices throughout the U.S., U.K. and Asia, ProLabs is able to be our customers best advocate 24 hours a day.

Contact Information

ProLabs US

Email: sales@prolabs.com

Telephone: 952-852-0252

ProLabs UK

Email: salessupport@prolabs.com

Telephone: +44 1285 719 600