

NOTES:

1. RECOMMENDED SOLDER INSTRUCTION SEE SHEET 2
2. IP RATING: IP 67
3. SEALED TO WITHSTAND PRESSURE UP TO 1,45 PSI FOR 30 MINUTES AFTER SOLDERING
4. METAL SHELL: ZINC DIE CAST; min. 50µin NICKEL PLATING over COPPER
5. INSULATORS: PBT GF UL 94 V-0, GREEN
6. O-RING: SILICONE PER ASTM D2000 70 SHORE A
7. SEALING COMPOUND: EPOXY RESIN UL 94 V-0; BLACK
8. SIGNAL CONTACTS: COPPER ALLOY PLATING (SEE PART NO):
 30µin HARD GOLD over min. 50µin NICKEL if 1□ in PART NO.
 8µin HARD GOLD over min. 50µin NICKEL if 3□ in PART NO.
 SOLDER CUP ACCEPTS CABLE AWG 20
9. HIGH POWER CONTACTS 20A: COPPER ALLOY; PLATING MATING SIDE (SEE PART NO):
 □ PLEASE ADD 1 for 30µin HARD GOLD over min. 50µin NICKEL
 □ PLEASE ADD 3 for 8µin HARD GOLD over min. 50µin NICKEL
 PLATING TERMINATION SIDE: 160-240µin TIN over 80µin NICKEL
 SOLDER CUP ACCEPTS CABLE AWG 12-14
10. HEXLOCKING SCREWS: STAINLESS STEEL
11. RECOMMENDED PANEL CUT-OUT ON SHEET 2
12. RECOMMENDED TORQUE FOR MOUNTING SCREW
 35Ncm (3.1 in.LB) / max.67Ncm (6 in.LB)
13. CONNECTOR IS PART MARKED: 15-00445□ CONEC ABC

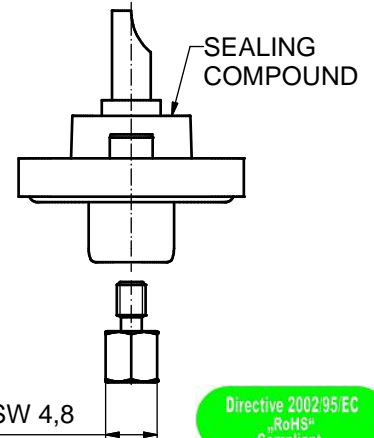
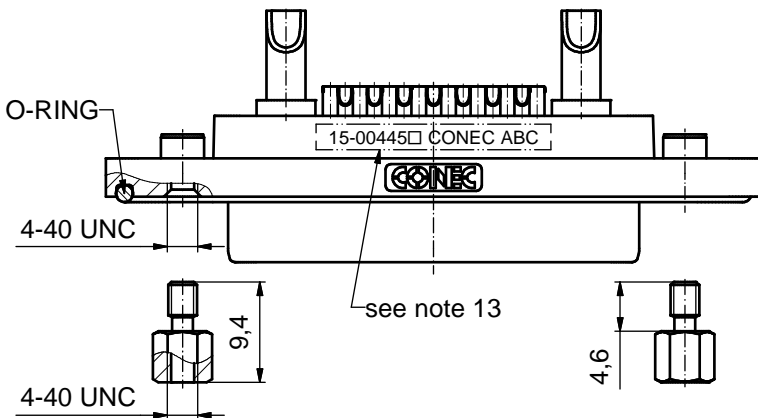
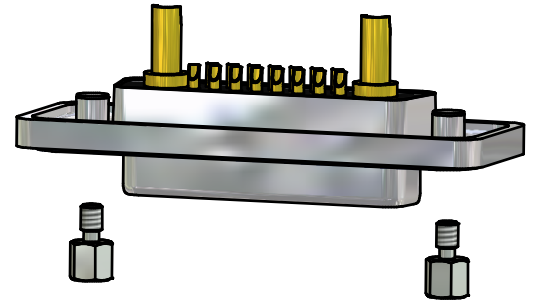
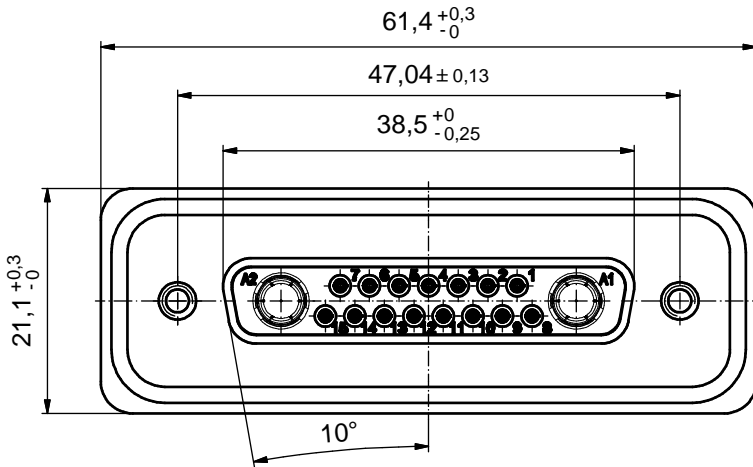
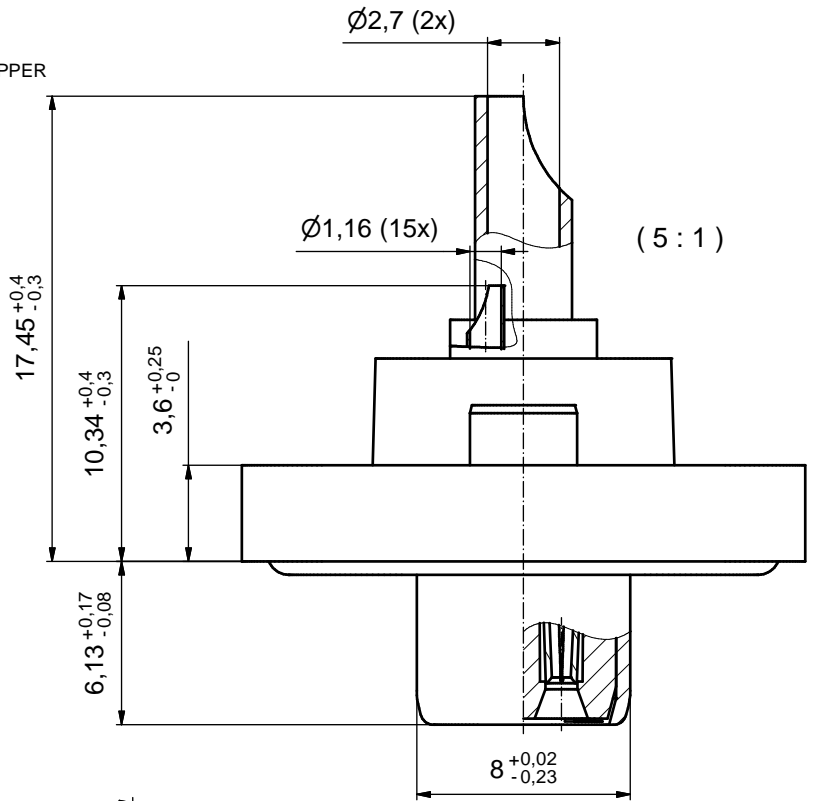

Directive 2002/95/EC
„RoHS“
Compliant

APPROVAL # FREIGABE # DEBLOCAGE # AUTORIZACION # APPROVAL	
CUSTOMER APPROVAL DATE:	
NAME:	TITLE:
COMPANY NAME:	
APPROVAL # FREIGABE # DEBLOCAGE # AUTORIZACION # APPROVAL	

THIS DRAWING MAY NOT BE COPIED OR REPRODUCED IN ANY WAY, AND MAY NOT BE PASSED ON TO A THIRD PARTY WITHOUT WRITTEN PERMISSION. OWNERSHIP AND COPYRIGHT OF CONEC GmbH			
DO NOT ALTER CAD DRAWING BY HAND			
rev.	description	date	name
a	Origin		

tolerance		dim. in mm
date	name	
drawn: 25.03.2010	Henneboel	
appd.: 25.03.2010	Fischer	
norm		
d-old		

scale: 2:1 (5:1)	
material: see notes	
title: D-SUB COMB. FEMALE 17W2S SOLDER CUP with hexlocking screw	
dwg no: Inventor 10	DIN-A3
15K1A603	
sh: 1	
part no: 15-00445□ (see note 9)	

Solder Instruction

1. Cable should be prepared for soldering. The cable/wires must be pretinned.
2. Insert cable/wire into solder cup.
3. Signal Contact
 - 3.1. Operate the soldering iron at 350°C, 50 Watt max. and use a pencil tip.
 - 3.2. Put tip to wire in solder cup.
 - 3.3. After 1 second bring in solder.
 - 3.4. Heat for 3 seconds longer. Do not heat contact more than 4 seconds in total.
4. Power Contact
 - 4.1. Operate the soldering iron at 350°C, 100 Watt max. and use a pencil tip.
 - 4.2. Put tip to wire in solder cup.
 - 4.3. After 1 second bring in solder.
 - 4.4. Heat for 5 seconds longer. Do not heat contact more than 6 seconds in total.
5. Remove soldering iron.
6. Wait until solder gets rigid again.
7. Do not solder adjacent contacts consecutively, alternate position within the connector to minimize heat build up.

RECOMMENDED PANEL CUT-OUT

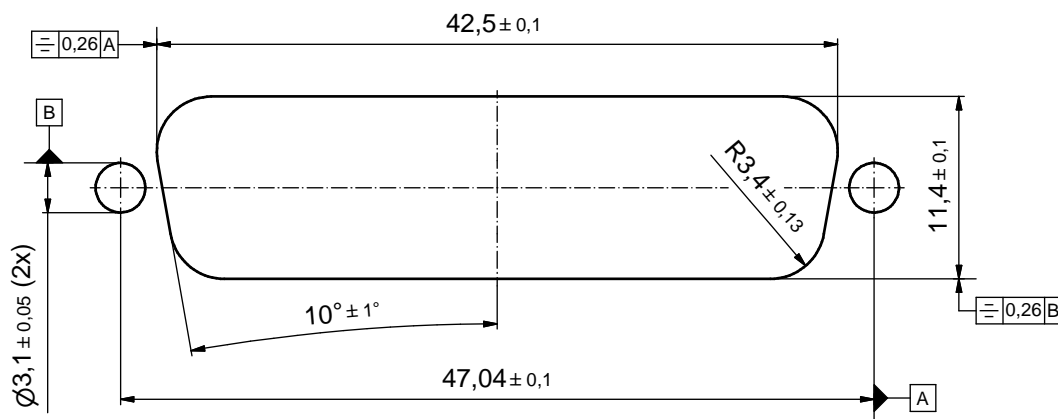

APPROVAL # FREIGABE # DEBLOCAGE # AUTORIZACION # APPROVAL		tolerance		dim. in mm		scale: 3:1	
CUSTOMER APPROVAL DATE:						material: see sheet 1	
NAME: TITLE:		date		name		title:	
		drawn: 25.03.2010		Henneboel		PANEL CUT-OUT	
		appd. 25.03.2010		Fischer		D-SUB COMBINATION FEMALE 17W2S	
		norm				Solder Cup; with hexlocking screw	
		d-old				dwg no: Inventor 10	
		a Origin				DIN-A3	
		rev. description date name		CONEC		15K1A603	
						sh: 2	
						part no: see sheet 1	
APPROVAL # FREIGABE # DEBLOCAGE # AUTORIZACION # APPROVAL		DO NOT ALTER CAD DRAWING BY HAND					
APPROVAL # FREIGABE # DEBLOCAGE # AUTORIZACION # APPROVAL		THIS DRAWING MAY NOT BE COPIED OR REPRODUCED IN ANY WAY AND MAY NOT BE PASSED ON TO A THIRD PARTY WITHOUT WRITTEN PERMISSION. OWNERSHIP AND COPYRIGHT OF CONEC GmbH					