



MALLORY SONALERT PRODUCTS, INC.

DATE: April 6, 2017

Please be advised that due to the obsolescence of the piezoelectric transducer in model numbers SC616WY, SC616WYR, SC616WXY, & SC616WXYR, a different piezoelectric transducer will need to be used.

This change in piezoelectric transducers has two consequences. First, the sound level specification at 16 Vdc has been changed from 72 dB min @ 2 ft to 69 dB min @ 2 ft. (a decrease of 3 dB). The human ear cannot tell that the sound level has changed until there is at least a 3 decibel change, so it is highly likely that this slight decrease in sound level will not affect the ability to hear the warning sound in the application. The second consequence of this transducer change is that the sound timbre has changed slightly. This means that the human ear can hear a difference when listening to the warning sounds of the current part as compared to the upcoming part because the sound frequency spectrum of the sound changes slightly.

Mallory can provide samples and sound files of the new design to current customers.

Mallory (and some Mallory distributors) still have stock of the current design. After all this stock is gone, any new orders will be filled with parts made of the new design.

The first attached page to this memo is the current specification sheet. The second attached page is the new specification sheet. Looking closely at the two specification sheets, the only differences are that the Revision Level changes and the Sound Level at 16 Vdc has decreased 3 decibels. As mentioned above, the other difference is that the sound timbre changes. To hear the difference in the warning sounds, you will need to compare the current sounds to the new sounds. This can be done by listening to the current sound file (on the website) and compare that to the new sound files (ask Mallory for these). You can also get samples of the new design to listen to the difference in person.

Daniel O'Brien
Mallory Sonalert Products, Inc

Sales Outline Drawing

Specifications:

Sound Level Category	Medium
Mode of Operation	5 Functions: Continuous -, Slow Pulse @ 0.5 - 2.5 PPS - High or Low Frequency, Warble
Voltage Rating	6 to 16 VDC
Frequency	Low - 1750 ± 500 Hz, High - 2900 ± 500 Hz
Loudness (Min Volt)	60 dB(A) min. @ 2 FT and 6 Vdc
Loudness (Max Volt)	72 dB(A) min. @ 2 FT and 16 Vdc
Loudness @ 2 FT	62 to 81 dB(A) Typ.
Current Draw	6-27 mA
Housing Material	6/6 Nylon, Color: Black
Storage Temperature	-40° to +85° C
Operating Temperature	-30° to +65° C
Panel Mounting	Recommended hole size is 1.25"(31.75mm). Thread front will fit standard 30mm(1.181") hole.
Knurled Nut	Used to attach part to panel. The max recommended torque is 10 in-lbs.
Weight (Typical)	2.1 oz (60g)
NEMA 3R,4X, & 12	Approved with use of ACC03.
Options	Please contact factory.

Dimensions: Inches (mm)

ROHS Compliant

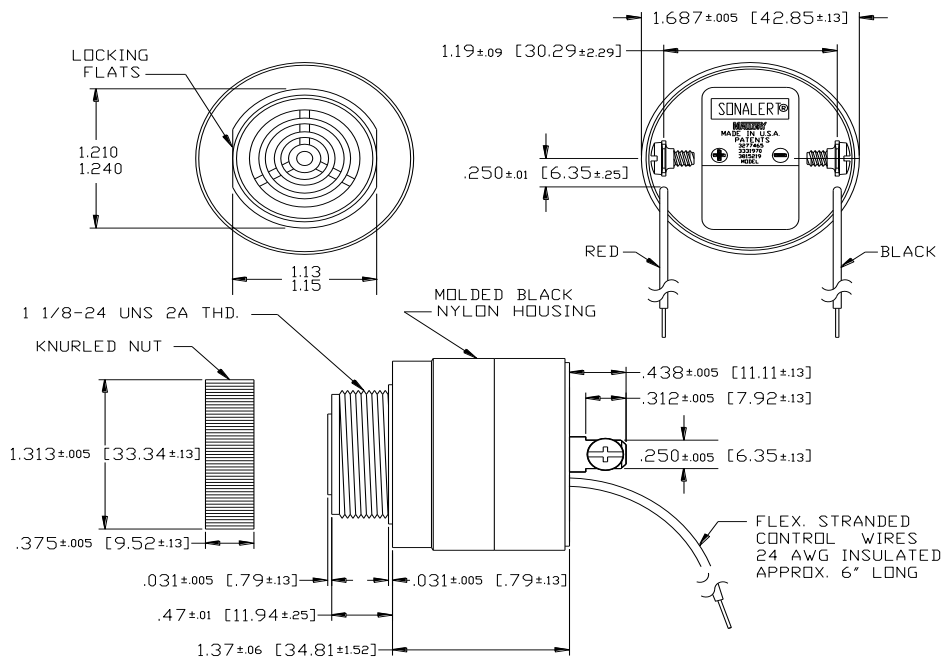

The red and black leads control the several functions. A logic 'Low' is a voltage less than 1/3 of supply voltage. A logic 'High' is a voltage greater than 1/2 supply voltage. A red or black input lead left unconnected is considered an open state.

Truth Table

Control Wire		Function Mode
Red	Black	
High	Low	Off
Open	High	High Continuous
Open	Low	Low Continuous
High	Open	High Pulse
Low	Open	Low Pulse
Open	Open	Warble

NOTE A: TERMINALS-.032 BRASS TIN PLATED, TAPPED FOR #6-32 SCREW. TWO #6-32 NICKEL PLATED BRASS SCREWS INCLUDED. WILL ACCEPT 1/4" QUICK CONNECT.

NOTE B: MOUNTING- REMOVE BLACK PLASTIC NUT AND INSERT THREADED FRONT THROUGH 1.25" HOLE PUNCHED IN PANEL. IF ORIENTATION IS NEEDED, NOTE LOCKING FLATS ON DRAWING. SCREW NUT BACK DN. DO NOT OVERTIGHTEN.

Sales Outline Drawing

Specifications:

Sound Level Category	Medium
Mode of Operation	5 Functions: Continuous -, Slow Pulse @ 0.5 - 2.5 PPS - High or Low Frequency, Warble
Voltage Rating	6 to 16 VDC
Frequency	Low - 1750 ± 500 Hz, High - 2900 ± 500 Hz
Loudness @ 2 FT	62 to 81 dB(A) Typ.
Loudness @ Min Vdc	60 dB(A) min @ 2 Feet and 6 Vdc
Loudness @ Max Vdc	69 dB(A) min @ 2 Feet and 16 Vdc
Current Draw	6-27mA
Duty Cycle (%)	50
Housing Material	6/6 Nylon, Color: Black
Storage Temperature	-40° to +85° C
Operating Temperature	-30° to +65° C
Panel Mounting	Recommended hole size is 1.25"(31.75mm). Thread front will fit standard 30mm(1.181") hole.
Knurled Nut	Used to attach part to panel. The max recommended torque is 10 in-lbs.
Weight (Typical)	2.1 oz (60g)
NEMA 3R,4X, & 12	Approved with use of ACC03.
Options	Please contact factory.

Dimensions: Inches (mm)

ROHS Compliant

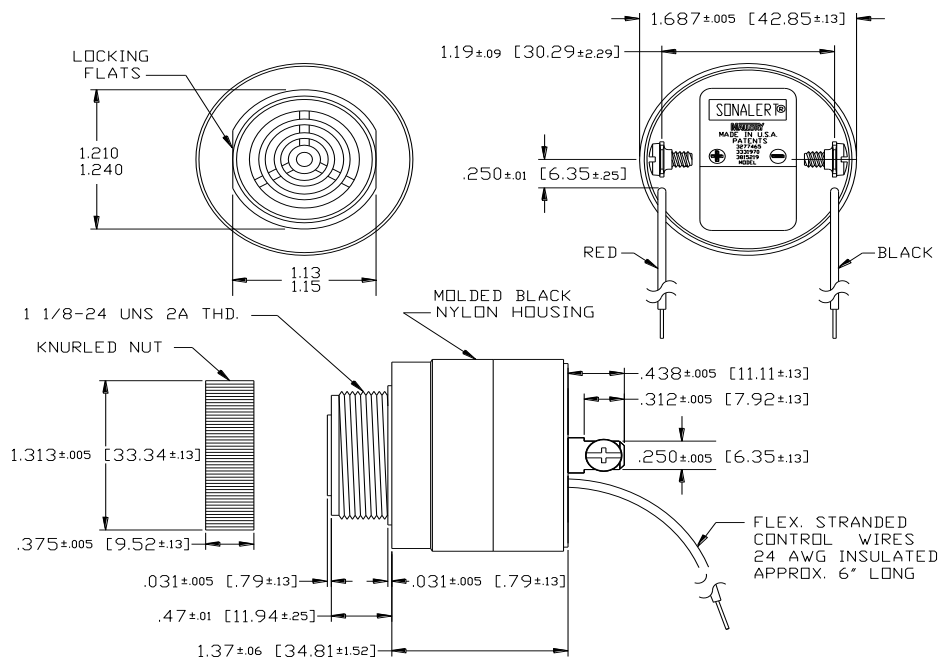

The red and black leads control the several functions. A logic 'Low' is a voltage less than 1/3 of supply voltage. A logic 'High' is a voltage greater than 1/2 supply voltage. A red or black input lead left unconnected is considered an open state.

Truth Table

Control Wire		Function Mode
Red	Black	
High	Low	Off
Open	High	High Continuous
Open	Low	Low Continuous
High	Open	High Pulse
Low	Open	Low Pulse
Open	Open	Warble

NOTE A: TERMINALS-.032 BRASS TIN PLATED, TAPPED FOR #6-32 SCREW. TWO #6-32 NICKEL PLATED BRASS SCREWS INCLUDED. WILL ACCEPT 1/4" QUICK CONNECT.

NOTE B: MOUNTING- REMOVE BLACK PLASTIC NUT AND INSERT THREADED FRONT THROUGH 1.25" HOLE PUNCHED IN PANEL, IF ORIENTATION IS NEEDED, NOTE LOCKING FLATS ON DRAWING. SCREW NUT BACK ON. DO NOT OVERTIGHTEN.