

Ratings

Temperature: -40~70 °C
Voltage: 150 V

Conductor

Gauge: 22 AWG 0.33 mm²
Material: tinned copper strands
Strand size: $\varnothing 0.08 \times 19$
Resistance at 20 °C: 59.4 Ω /km max

Insulator

Material: HDPE
Color: brown, gray, purple, orange, green, blue, yellow, white, black, red
Diameter: $\varnothing 1.25 \pm 0.10$ mm
Nominal thickness: 0.25 mm
Resistance at 20 °C: 100 M Ω /km min

Shield

Type: spiral
Material: tinned copper strands
Stranding: $\varnothing 0.08$ mm
Coverage: 90 % min

Outer jacket

Material: TPU
Color: black
Nominal thickness: 0.70 mm
Diameter: $\varnothing 6.6 \pm 0.25$ mm

Filler

Material: aramid fiber

Tests

Tensile strength: 35.7 kgf min
Dielectric test: 1500 V dc for 1 minute without breakdown
Bend test at 200 g, $\pm 90^\circ$, 30 cycles /min: 15,000 cycle minimum

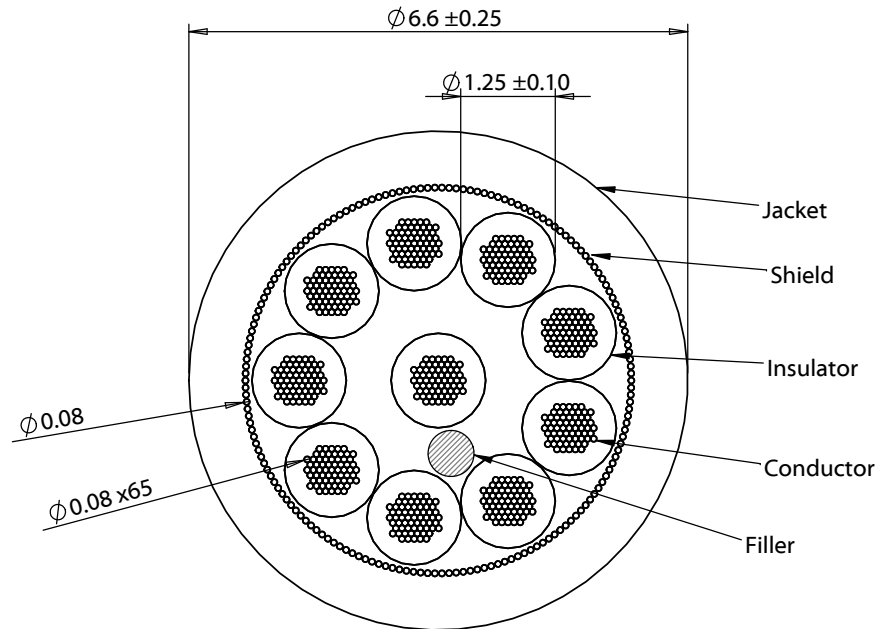
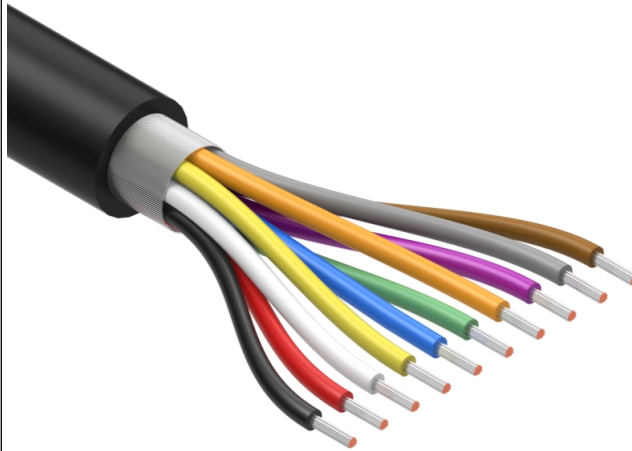

Revision:	Date:	Description:	Prepared:	Notes: RoHS compliant Jacket meets ISO 10993 Biological Compatibility Phthalate and halogen free Function test: no open, no short, no intermittent	TENSILITY tel 1.541.323.3228 800 877.670.7118 fax 1.541.323.4202 web tensility.com
A	3/23/2021	Initial release	Verified:		
			Dimensions are in millimeters. Tolerances: X: ± 0.5 mm X.X: ± 0.3 mm X.XX: ± 0.05 mm	Description:	Size: Part number:
				Wire, 10C TS, 22 AWG, 150V, 70C, 6.6 mm, shielded, TPU, 75A, WBL	A 30-01884
				Scale: 10:1	Sheet 1 of 1

5

4

3

2

1