

C-539678-2

DWG NO

THIS DRAWING IS A CONTROLLED DOCUMENT FOR THE MANUFACTURING AND THE CONTROLLING ENGINEERING ORGANIZATION AND SHOULD BE CONTACTED FOR THE LATEST REVISION.

DIESES ZEICHNUNGS-DOKUMENT WIRD DURCH AMP INCORPORATED KONTROLLIERT. ANMERKUNGEN, DIE DEM TECHNISCHEN FORTSCHRITT DIENTEN, SIND VORBEHALTEN. DEN JEWEILS LETZTLIEGENDEN ABEREINIGUNGSSTAND ERFAHREN SIE AUF ANFRAGE.

THIS INFORMATION IS CONFIDENTIAL AND IS DISCLOSED TO YOU BY YOU TO OTHER THAN AMP PERSONNEL WITHOUT WRITTEN AUTHORIZATION FROM AMP INCORPORATED, D-62523 JANSSEN

PASSMASS	ABMASS

ERGOCRIMP DIE SET FOR ECONOSEAL 6,3mm SWS WIRE RANGE 0,75-1,5 mm²

PROJECT NO.: -

USED ON

Matrize in Kombination mit Ergocrimp Basishandzange TE P/N 539635-1 verwenden
Use die set in combination with Ergocrimp basis hand tool TE P/N 539635-1

Matrize im Karton mit Bedienungsanleitung 411-18128 verpackt
Die set packed in a cardboard with instruction sheet 411-18128

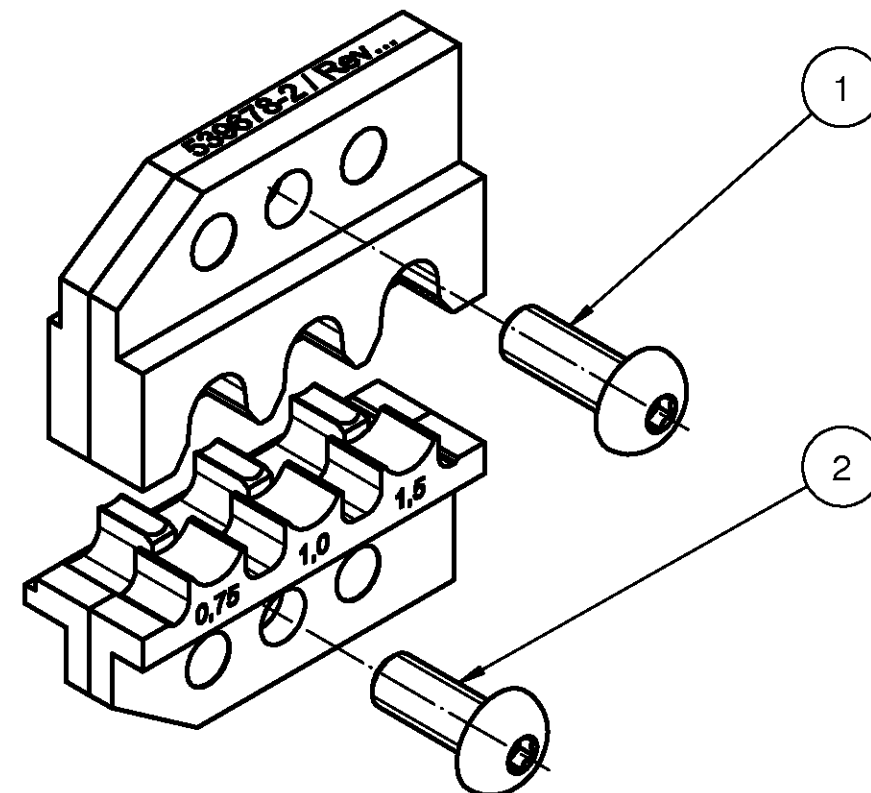

539678-2	1	8-0744001-9	Instruction Sheet	Bedienungsanleitung	3
	1	0-0519151-9	Screw M4x10	Schraube M4x10	2
	1	8-0539634-5	Screw M4x11	Schraube M4x11	1
	QTY Stck	TE P/N	Description	Benennung	Pos.

Kontakt	DGB (mm ²)	Drahtcrimp / Wire Crimp		Isolationscrimp / Insulation Crimp		Isol.Ø	Betriebsanl.
Contact	Wire Range	Höhe / Height mm	Breite / Width mm	Höhe / Height mm	Breite / Width mm	Ins. Range	Instr. Sheet
344070	0,75	1,36 ±0,05	2,03 F	4,50	5,30 O	1,7 - 1,9	411-18128
	1,0	1,46 ±0,05		4,60		1,9 - 2,1	
	1,5	1,65 ±0,05		4,70		2,2 - 2,4	

FREI-MASSTOLERANZEN NACH DIN 7168 (WERTE IN mm)

1) ABWEICHEND VON DIN 7168 2) LÄNGE DES KÜRZEREN SCHENKELS

NENNMASS-BEREICH 1)	ÜBER	0,5	3	6	30	120	400
BIS	3	6	30	120	400	1000	

ABMASSE	LÄNGEN-	MASSE	MITTEL	± 0,1	± 0,1	± 0,2	± 0,3	± 0,5	± 0,8
RADIEN U. FASEN				± 0,2	± 0,5	± 1	± 2	± 4	± 4
WINKELABMASSE 1) 2)				± 1'	± 1'	± 30'	± 20'	± 10'	± 5'

GENERAL TOLERANCES ACC. TO DIN 7168 (VALUES IN mm)

1) DEVIATING FROM DIN 7168 2) LENGTH OF SHORT ANGLE SIDE

TEIL IM BEREICH X... MIT PN-STRICH-NR. (-1 WIE GEZ.), REVISION-STAND UND LIEFERANTENS YMBOL GEKENNZEICHNET

PART TO BE MARKED WITH PN-DASH NO. (-1 AS SHOWN), REV. STATUS AND VENDORS MARK IN AREA X...

LOC	AI	DIST	
-----	----	------	--

ALLE UNBEMASSTE KANTEN 0,2x45° ENTGRÄTET
REMOVE BURRS, BREAK SHARP EDGES 0,2x45°

BOHRG- OHNE ANGABE	12,5	HOLE NOT SPEC
P	LTR	

REVISION RECORD

DATE	DWN	APVD

FINISH

DIMENSIONS: mm

TOLERANCES UNLESS OTHERWISE SPECIFIED:

n. ISO 2768: MH-E 140

n. DIN 16901: 4-PLC ±, 1-PLC ±, 2-PLC ±, 3-PLC ±, 4-PLC ±

ANGLES:

SURFACE TEXTURE: ✓

DWN	10.12.2008	MATERIAL	
CHK	P. Demmer	HEAT TREAT	0,049
APVD	10.12.2008	Tyco Electronics AMP GmbH 64625 Bensheim (Germany)	
NAME	ERGOCRIMP DIE SET FOR ECONOSEAL 6,3mm SWS Ergocrimp Matrize für ECONOSEAL 6,3mm EDS		
SCALE	2:1	SIZE	A3
DRAWING NO	C-539678-2	SHEET	1 OF 1
REV	A		