

CODE No.	CONTACT	A	B	C	D	E	F
CL537-0453-2-81	20	7.2	4.5	5.3	5.7	6.6	5.3
CL537-0455-8-81	30	9.7	7.0	7.8	8.2	9.1	7.8
CL537-0928-8-81	32	10.2	7.5	8.3	8.7	9.6	8.3
CL537-0456-0-81	36	11.2	8.5	9.3	9.7	10.6	9.3
CL537-0457-3-81	40	12.2	9.5	10.3	10.7	11.6	10.3
CL537-0459-9-81	50	14.7	12.0	12.8	13.2	14.1	12.8
CL537-0461-0-81	60	17.2	14.5	15.3	15.7	16.6	15.3

RECOMMEND METAL MASK PATTERN (10:1)

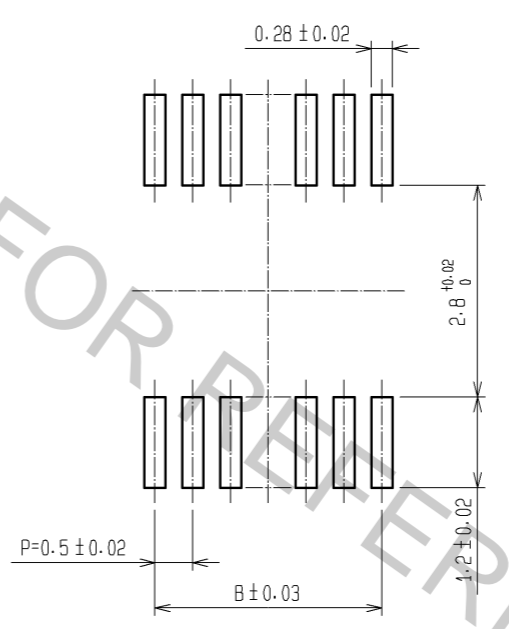

RECOMMENDED THICKNESS OF METAL MASK : 120 μm

RECOMMENDED LAND PATTERN (10:1)

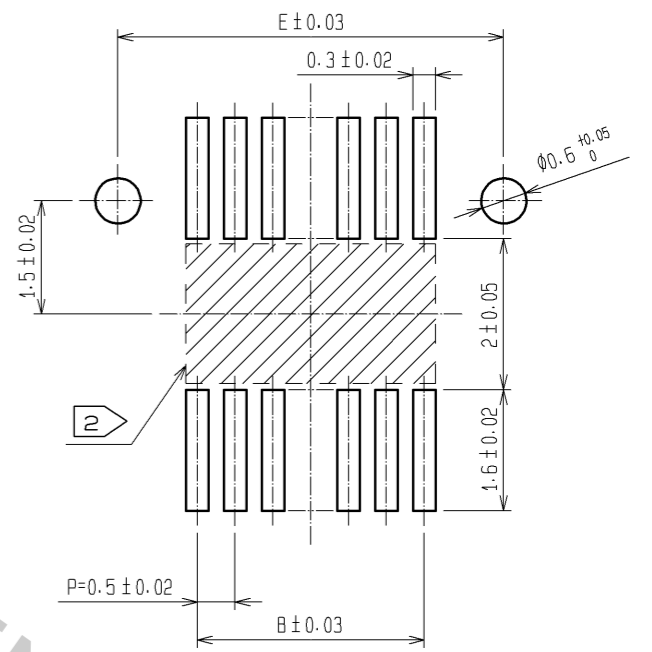

RECOMMENDED THICKNESS OF SOLDER PASTE : 120 μm

NOTES 1 LEAD CO-PLANARITY SHALL BE 0.08 mm MAX.  
 2 IF THERE IS PATTERN ON PART, THERE IS A POSSIBILITY THAT IT WILL MAKE CONTACT WITH THE LEADS.

NO.	MATERIAL	FINISH . REMARKS	NO.	MATERIAL	FINISH . REMARKS
2	PHOSPHOR BRONZE	CONTACT AREA:GOLD PLATED 0.2μm min LEAD AREA:GOLD PLATED 0.015μm min OTHERS(UNDER PLATING):NICKEL PLATED 2μm min	6	PS	CLEAR (REINFORCEMENT COLLAR)
			5	PS	BLACK (PLASTIC REEL)
			4	POLYESTER	CLEAR (COVER TAPE)
1	POLYAMIDE	UL94V-0.NATURAL(BEIGE)	3	PS	CLEAR (EMBOSSED CARRIER TAPE)

UNITS	SCALE	COUNT	DESCRIPTION OF REVISIONS	DESIGNED	CHECKED	DATE
mm	5 : 1	△				
APPROVED : KH. IKEDA			13.08.19	DRAWING NO. EDC3-163517-77		
CHECKED : YH. MICHIDA			13.08.09	PART NO. DF12D(4.0)-*DP-0.5V(81)		
DESIGNED : YN. SAKAMOTO			13.08.08	CODE NO. CL537		
DRAWN : KR. AJITO			13.08.08	△ 1/2		

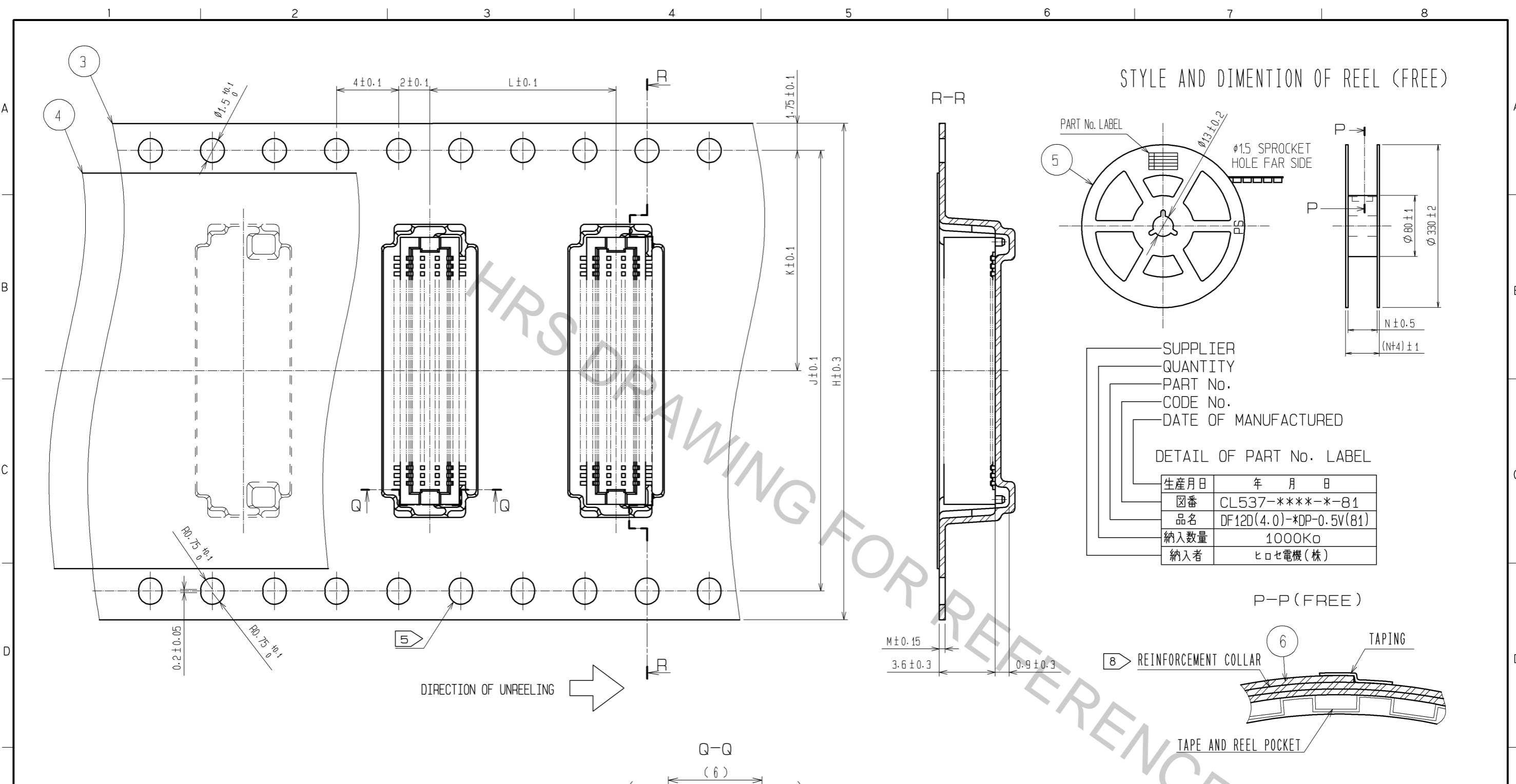

STYLE AND DIMENSION OF REEL (FREE)

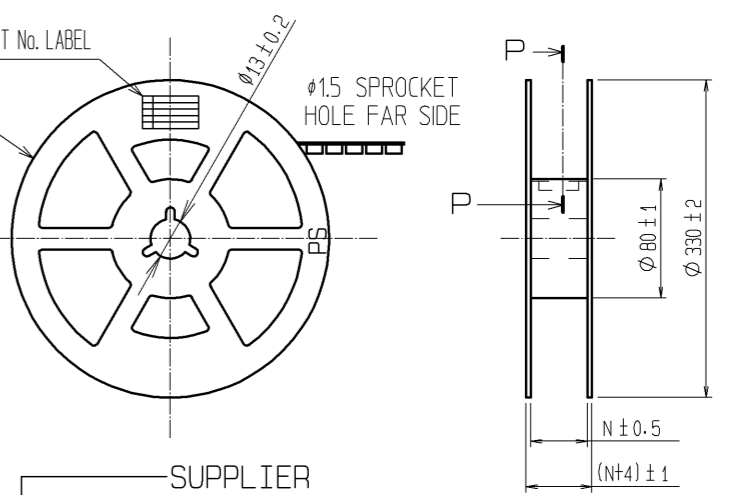

SUPPLIER  
QUANTITY  
PART No.  
CODE No.  
DATE OF MANUFACTURED

DETAIL OF PART No. LABEL

生産月日	年 月 日
図番	CL537-****-*81
品名	DF12D(4.0)*DP-0.5V(81)
納入数量	1000K
納入者	ヒロセ電機(株)

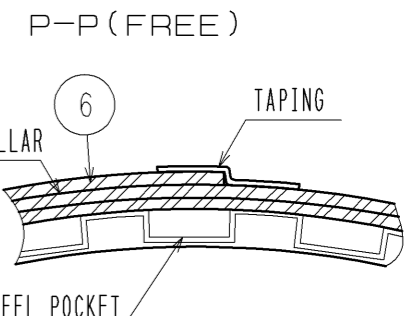

CODE No.	CONTACT	H	J	K	L	M	N
CL537-0453-2-81	20	16	-	7.5	12.0	0.30	17.5
CL537-0455-8-81	30	24	-	11.5	12.0	0.38	25.5
CL537-0928-8-81	32	24	-	11.5	12.0	0.30	25.5
CL537-0456-0-81	36	24	-	11.5	8.0	0.30	25.5
CL537-0457-3-81	40	24	-	11.5	12.0	0.38	25.5
CL537-0459-9-81	50	24	-	11.5	8.0	0.30	25.5
CL537-0461-0-81	60	32	28.4	14.2	12.0	0.30	33.5

- NOTES
- 3 1 REEL 1000 CONNECTORS.
  - 4 AT THE BEGINNING OF THE REEL, 30 COMPONENTS SHALL BE EMPTY. AT THE END OF THE REEL, 20 COMPONENTS SHALL BE EMPTY.
  - 5 WHEN THE TAPE WIDTH IS 32 mm, SPROCKET HOLES SHALL BE SET ON BOTH SIDE OF REEL AS SHOWN ON THIS DRAWING.
  - 6 PEEL FORCE REFERS TO JIS C 0806. (IEC 60286-3)
  - 7 THE REEL IS PACKED WITH A POLYETHYLENE MATERIAL, TOGETHER WITH A DRYING AGENT.
  - 8 AFTER PACKING, ROLL 2 METERS OF THE REINFORCEMENT COLLAR TO OUTER CIRCUMFERENCE OF TAPE AND REEL POCKET, AND TAPE DOWN AT THE END THE COLLAR.

<b>HRS</b>	DRAWING NO.	EDC3-163517-77
	PART NO.	DF12D(4.0)*DP-0.5V(81)
	CODE NO.	CL537
		△ 2/2