

Panel feed-through terminal block - HDFKV 10-TWIN - 0709550

Please be informed that the data shown in this PDF Document is generated from our Online Catalog. Please find the complete data in the user's documentation. Our General Terms of Use for Downloads are valid (<http://phoenixcontact.com/download>)



The figure shows a 6-position version

Panel feed-through terminal block, connection method: Screw connection, Screw connection, number of positions: 1, load current: 76 A, cross section: 0.5 mm² - 16 mm², AWG 20 - 6, connection direction of the conductor to plug-in direction: 90 °, width: 10.1 mm, color: gray

Your advantages

- ✓ Easy grouping with engagement pin versions
- ✓ Both terminal halves can be easily assembled by simply snapping them together
- ✓ Automatic compensation of the panel thickness via the snap principle integrated in the insulation housing
- ✓ Universal screw connection with screw locking
- ✓ Ideal for looping through power supply cables
- ✓ Well-known connection principle allows worldwide use
- ✓ Low temperature rise, thanks to maximum contact force
- ✓ Tool-free snap-in principle enables easy mounting on the device panel
- ✓ Automatic panel thickness compensation enables universal use



Key Commercial Data

Packing unit	50 pc
GTIN	 4 017918 005030
GTIN	4017918005030

Technical data

General

Number of levels	1
Number of connections	3
Nominal cross section	10 mm ²
Color	gray
Insulating material	PA
Flammability rating according to UL 94	V0

Panel feed-through terminal block - HDFKV 10-TWIN - 0709550

Technical data

General

Maximum load current	76 A
Rated surge voltage	6 kV
Degree of pollution	3
Overvoltage category	III
Insulating material group	I
Connection in acc. with standard	IEC 60947-7-1
Nominal current I _N	57 A
Maximum load current	76 A
Nominal voltage U _N	400 V (With metal panels of 1 mm ... 2.5 mm)
	250 V (With metal panels over 2.5 mm ... 4 mm)
	500 V (With plastic panels of 1 mm ... 4 mm)
Open side panel	No
Number of positions	1

Dimensions

Width	10.1 mm
Pitch	10.1 mm
Plate thickness	1 mm ... 4 mm

Connection data

Note	Terminal sleeve
Connection side	Level 1 ext. 1
Connection method	Screw connection
Conductor cross section solid min.	0.5 mm ²
Conductor cross section solid max.	16 mm ²
Conductor cross section flexible min.	0.5 mm ²
Conductor cross section flexible max.	10 mm ²
Conductor cross section AWG min.	20
Conductor cross section AWG max.	6
Conductor cross section flexible, with ferrule without plastic sleeve min.	0.5 mm ²
Conductor cross section flexible, with ferrule without plastic sleeve max.	10 mm ²
Conductor cross section flexible, with ferrule with plastic sleeve min.	0.5 mm ²
Conductor cross section flexible, with ferrule with plastic sleeve max.	10 mm ²
2 conductors with same cross section, solid min.	0.5 mm ²
2 conductors with same cross section, solid max.	4 mm ²
2 conductors with same cross section, stranded min.	0.5 mm ²
2 conductors with same cross section, stranded max.	4 mm ²
2 conductors with same cross section, stranded, ferrules without plastic sleeve, min.	0.5 mm ²
2 conductors with same cross section, stranded, ferrules without plastic sleeve, max.	2.5 mm ²
2 conductors with same cross section, stranded, TWIN ferrules with plastic sleeve, min.	0.5 mm ²

Panel feed-through terminal block - HDFKV 10-TWIN - 0709550

Technical data

Connection data

2 conductors with same cross section, stranded, TWIN ferrules with plastic sleeve, max.	6 mm ²
Cross section with insertion bridge, solid max.	10 mm ²
Cross section with insertion bridge, stranded max.	10 mm ²
Stripping length	11 mm
Internal cylindrical gage	B6
Screw thread	M4
Tightening torque, min	1.5 Nm
Tightening torque max	1.8 Nm
Connection side	inside
Connection method	Screw connection

Standards and Regulations

Connection in acc. with standard	CSA
	IEC 60947-7-1
Flammability rating according to UL 94	V0

Environmental Product Compliance

REACH SVHC	Lead 7439-92-1
China RoHS	Environmentally Friendly Use Period = 50
	For details about hazardous substances go to tab "Downloads", Category "Manufacturer's declaration"

Drawings

Panel feed-through terminal block - HDFKV 10-TWIN - 0709550

Dimensional drawing

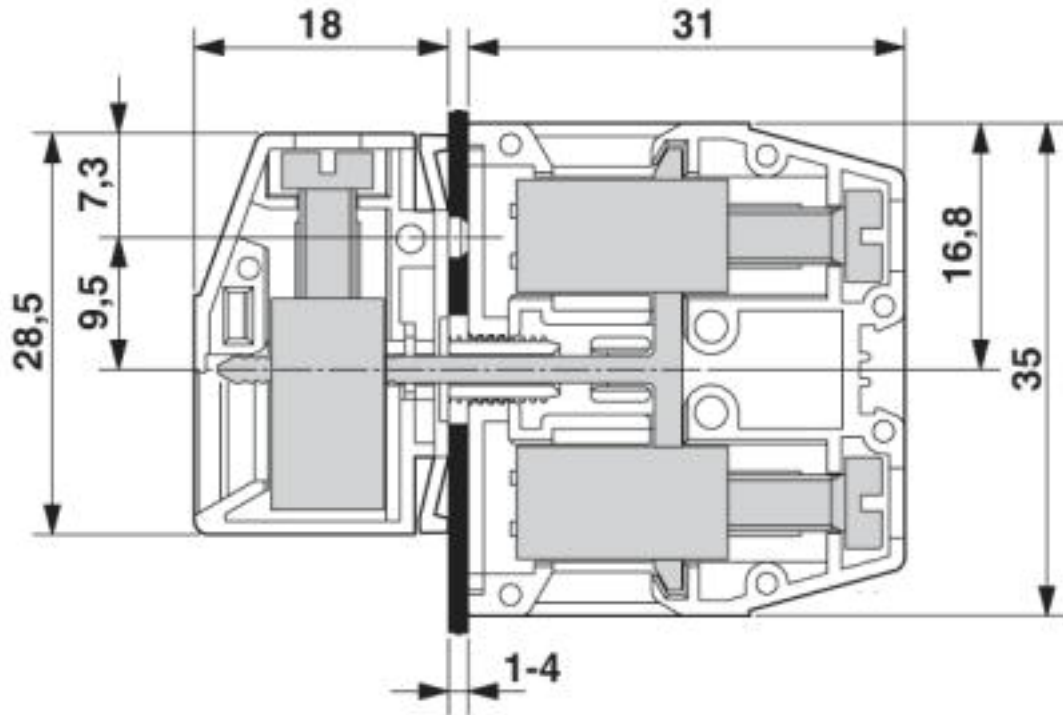

Dimensional drawing

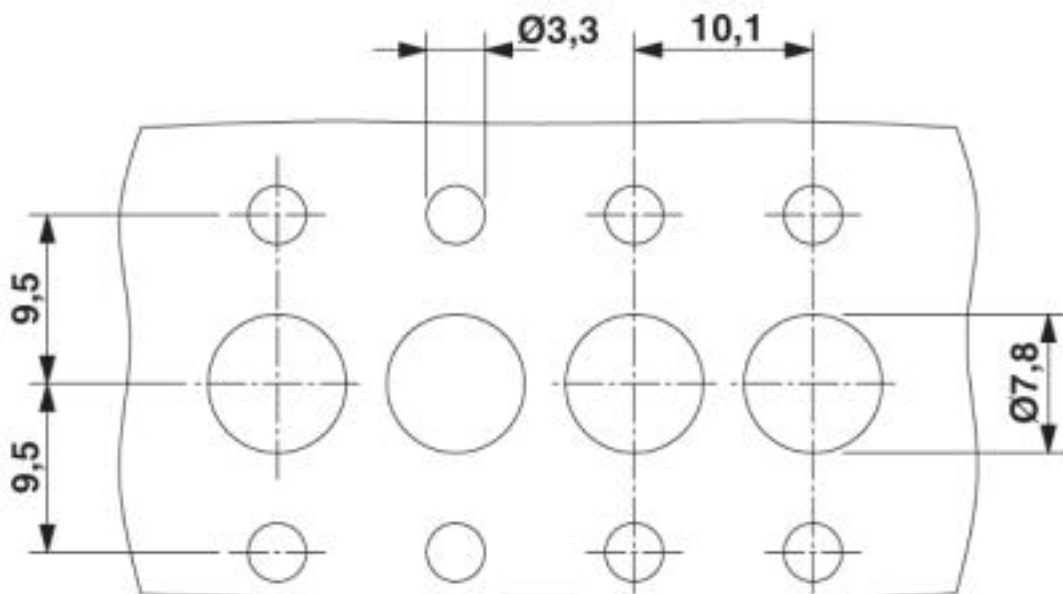

Approvals

Approvals

Panel feed-through terminal block - HDFKV 10-TWIN - 0709550

Approvals

Approvals

CSA / EAC / cULus Recognized

Ex Approvals

Approval details

CSA		http://www.csagroup.org/services-industries/product-listing/	13631
		B	D
Nominal voltage UN		300 V	300 V
Nominal current IN		65 A	10 A
mm ² /AWG/kcmil		22-6	22-6

EAC			B.01742
-----	--	--	---------

cULus Recognized		http://database.ul.com/cgi-bin/XYV/template/LISEXT/1FRAME/index.htm	E60425-19870911	
		B	C	D
Nominal voltage UN		300 V	150 V	300 V
Nominal current IN		65 A	65 A	10 A
mm ² /AWG/kcmil		24-6	24-6	24-6

Phoenix Contact 2019 © - all rights reserved
<http://www.phoenixcontact.com>

PHOENIX CONTACT GmbH & Co. KG
Flachsmarktstr. 8
32825 Blomberg
Germany
Tel. +49 5235 300
Fax +49 5235 3 41200
<http://www.phoenixcontact.com>