

L-15212-10

REL	WAS	DATE	D'MAN	APPD.
32508-224				
1	51710-1	REDRAWN TO STANDARD AA SIZE FORM.	1-3-57	GREER <i>B. Greer</i>
2	32525-449	ADD. SERVICE RATING: TYPE I	9-12-57	F. GEORGE <i>F. George</i>
3	35525-826	20 M (2 PLACES); ADD ALT POS NOTE	7-13-59	LAMBERT <i>L. Lambert</i>
A ₁	42620-117	(MFG); STD PRACTICE	5-26-64	Handall <i>Handall</i>

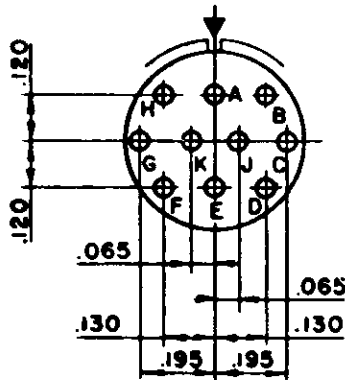

10-SIZE 20 CONTACTS

3

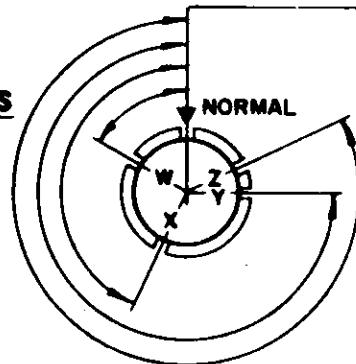

CONSIDER INSERT POSITION FIXED WITH SHELL ROTATING TO ALTERNATE POSITION

3

ARR NO.	ALTERNATE KEYWAY POS			
	W	X	Y	Z
-10	60°	155°	270°	295°

NOTE:

1. FRONT FACE OF PIN INSERT SHOWN.

SERVICE RATING: TYPE I

MATERIAL SPEC.	PROCESS SPEC.	SCINTILLA DIVISION					TOLERANCES UNLESS OTHERWISE SPECIFIED		
		BENDIX AVIATION CORPORATION SIDNEY, N. Y., U.S.A.					FRACTIONS ± ~	DECIMALS ± ~	ANGLES ± ~
HEAT TREAT SPEC.	FINISH SPEC.	NAME					CONCENTRICITY TIR ~		SURFACE ROUGHNESS MICRO-IN RMS MAX. ~
		INSERT ARRANGEMENT, SIZE 12-1020					NEXT ASSEMBLY	WEIGHT - LBS.	
C. R.		D'MAN	CHECKER	MAT.	SYMB.	CH. D'MAN	APPROVED	SCALE	L-15212-10
		GREER	<i>Greer</i>				<i>Handall</i>	NONE	
		7-13-56	1-21-57						CODE 77820