

MATERIAL NO.	# OF CIRC. "XX"	"A"	"B"	"C"	"D"
387419702	2	43.5 (1.71)	11.1 (.44)	33.3 (1.31)	24.6 (.97)
387419703	3	54.6 (2.15)	22.2 (.88)	44.5 (1.75)	35.7 (1.40)
387419704	4	65.7 (2.59)	33.3 (1.31)	55.6 (2.19)	46.8 (1.84)
387419705	5	76.8 (3.03)	44.5 (1.75)	66.7 (2.63)	57.9 (2.28)
387419706	6	87.9 (3.46)	55.6 (2.19)	77.8 (3.06)	69.0 (2.72)
387419707	7	99.1 (3.90)	66.7 (2.63)	88.9 (3.50)	80.1 (3.15)
387419708	8	110.2 (4.39)	77.8 (3.06)	100.0 (3.94)	91.2 (3.59)
387419709	9	121.3 (4.78)	88.9 (3.50)	111.1 (4.38)	102.3 (4.03)
387419710	10	132.4 (5.21)	100.0 (3.94)	122.2 (4.81)	113.4 (4.47)
387419711	11	143.5 (5.65)	111.1 (4.38)	133.4 (5.25)	124.6 (4.90)
387419712	12	154.6 (6.09)	122.2 (4.81)	144.5 (5.69)	135.7 (5.34)
387419713	13	165.7 (6.53)	133.4 (5.25)	155.6 (6.13)	146.8 (5.78)
387419714	14	176.8 (6.96)	144.5 (5.69)	166.7 (6.56)	157.9 (6.22)
387419715	15	188.0 (7.40)	155.6 (6.13)	177.8 (7.00)	169.0 (6.65)
387419716	16	199.1 (7.84)	166.7 (6.56)	188.9 (7.44)	180.1 (7.09)
387419717	17	210.2 (8.28)	177.8 (7.00)	200.0 (7.88)	191.2 (7.53)
387419718	18	221.3 (8.71)	188.9 (7.44)	211.1 (8.31)	202.3 (7.97)
387419719	19	232.4 (9.15)	200.0 (7.88)	222.3 (8.75)	213.5 (8.40)
387419720	20	243.5 (9.59)	211.1 (8.31)	233.4 (9.19)	224.6 (8.84)
387419721	21	254.6 (10.03)	222.3 (8.75)	244.5 (9.63)	235.7 (9.28)
387419722	22	265.7 (10.46)	233.4 (9.19)	255.6 (10.07)	246.8 (9.72)
387419723	23	276.8 (10.90)	244.5 (9.63)	266.7 (10.51)	257.9 (10.15)
387419724	24	288.0 (11.34)	255.6 (10.07)	277.8 (10.95)	269.0 (10.59)
387419725	25	299.1 (11.78)	266.7 (10.51)	288.9 (11.39)	280.1 (11.03)
387419726	26	310.2 (12.21)	277.8 (10.95)	300.0 (11.83)	291.2 (11.47)
387419727	27	321.3 (12.65)	288.9 (11.39)	311.1 (12.27)	302.3 (11.90)
387419728	28	332.4 (13.09)	300.0 (11.83)	322.3 (12.71)	313.5 (12.34)
387419729	29	343.5 (13.53)	311.2 (12.27)	333.4 (13.15)	324.6 (12.78)
387419730	30	354.6 (13.96)	322.3 (12.69)	344.5 (13.59)	335.7 (13.22)

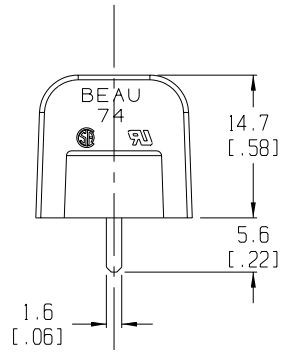
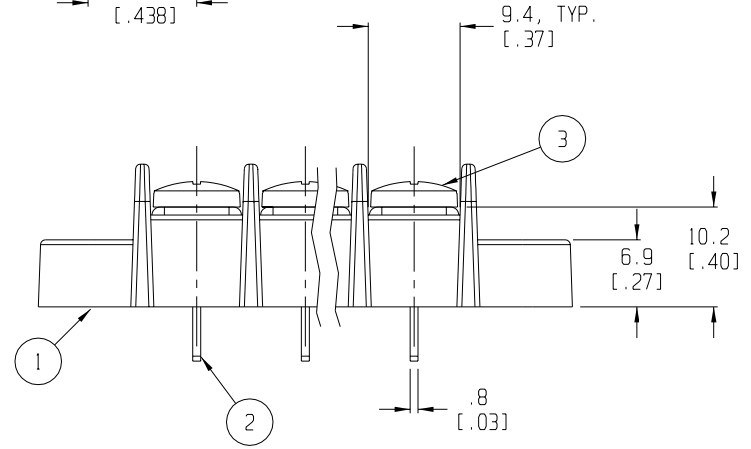
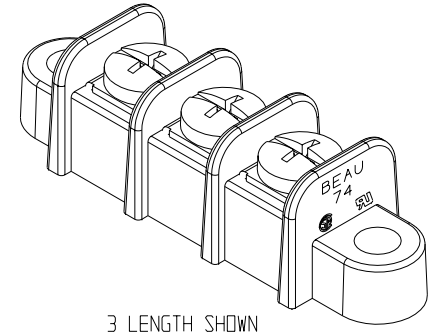
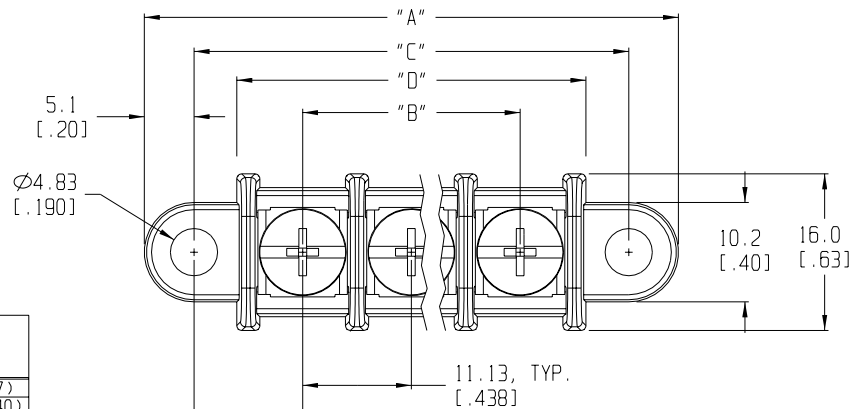

- NOTES:
1. MATERIAL: SEE TABLE
 2. FINISHES: SEE TABLE
 3. PRODUCT SPECIFICATION: NOT REQUIRED
 4. PACKAGING: NOT REQUIRED
 5. MATES WITH: NONE

ITEM	QTY.	DESCRIPTION	MATERIAL	FINISH
3	XX	SCREW	BRASS	NICKEL
2	XX	TERMINAL	BRASS	TIN
1	1	BARRIER	THERMOPLASTIC	BLACK

EC NO. RELEASED DRN: CY CH: K: APPR: A	DESCRIPTION MAJOR CRITICAL SPC S	QUALITY SYMBOLS		GENERAL TOLERANCES: (UNLESS SPECIFIED)		SCALE 2:1	DESIGN UNITS <input type="checkbox"/> mm <input checked="" type="checkbox"/> INCH	THIRD ANGLE PROJECTION	PROJECT NO. - 1 - DIMENSIONS: SHT REV <input checked="" type="checkbox"/> mm <input type="checkbox"/> INCH <input type="checkbox"/> mm ONLY <input type="checkbox"/> INCH
		4 PLACES ±.038 INCH ±.0015	3 PLACES ±.038 INCH ±.005	DRAWN BY & DATE C. YORR 6-5-03	TITLE: SR BTS PC ASSY, #8-32 SCREW				
		2 PLACES ±.13 INCH ±.01	1 PLACE ±.3 INCH	CHECKED BY & DATE	APPROVED BY & DATE				
		ANGULAR: ±2°		CAD FILENAME 745XX-A	MATERIAL NO. SEE CHART	DRAWING NO. SD-38741-001	SHEET NO. 1 OF 1		
DRAFT WHERE APPLICABLE MUST REMAIN WITHIN DIMENSIONS						THIS DRAWING CONTAINS INFORMATION THAT IS PROPRIETARY TO MOLEX INCORPORATED AND SHOULD NOT BE USED WITHOUT WRITTEN PERMISSION.			