

THIS DRAWING IS UNPUBLISHED. RELEASED FOR PUBLICATION  
 © COPYRIGHT - By - ALL RIGHTS RESERVED.

REVISIONS					
P	LTR	DESCRIPTION	DATE	DWN	APVD
B1		REVISED PER ECR-11-025318	19DEC11	KH	GJ
B2		REVISED PER ECR-17-002254	16FEB17	ST	TD

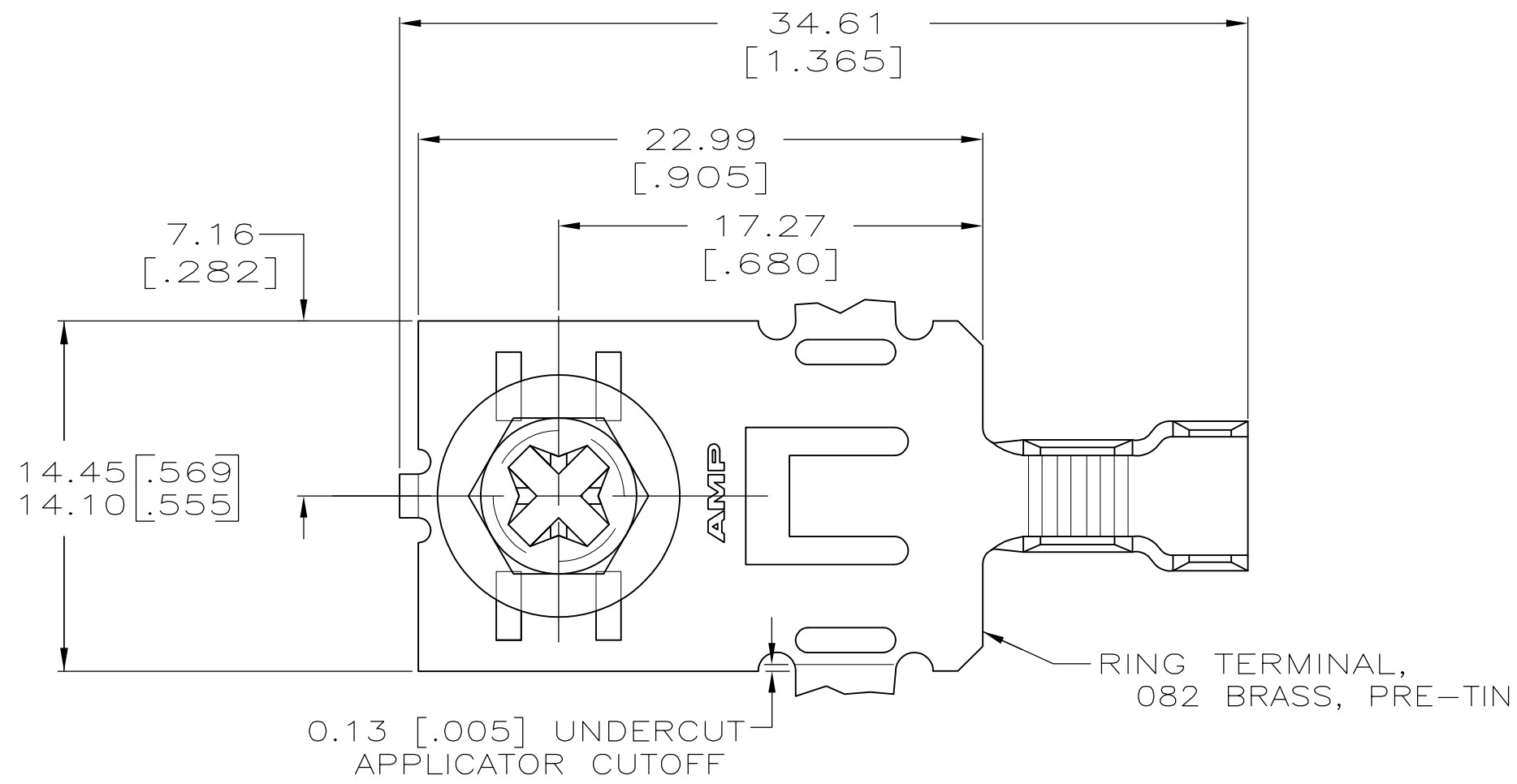

- 1 CONTINUOUS STRIP ON REEL.
- 2 VERTICAL BURRS NOT TO EXCEED 0.13 [.005] ALONG THIS EDGE.
- 3 BACK OUT TORQUE OF SCREW TO BE A MIN OF 5 INCH LBS AND A MAX OF 25 INCH LBS.
- 4 REFERENCE APPLICATOR LOG SHEET FOR CRIMP INFORMATION.
- 5 PART TO HAVE HARDENED NUTS

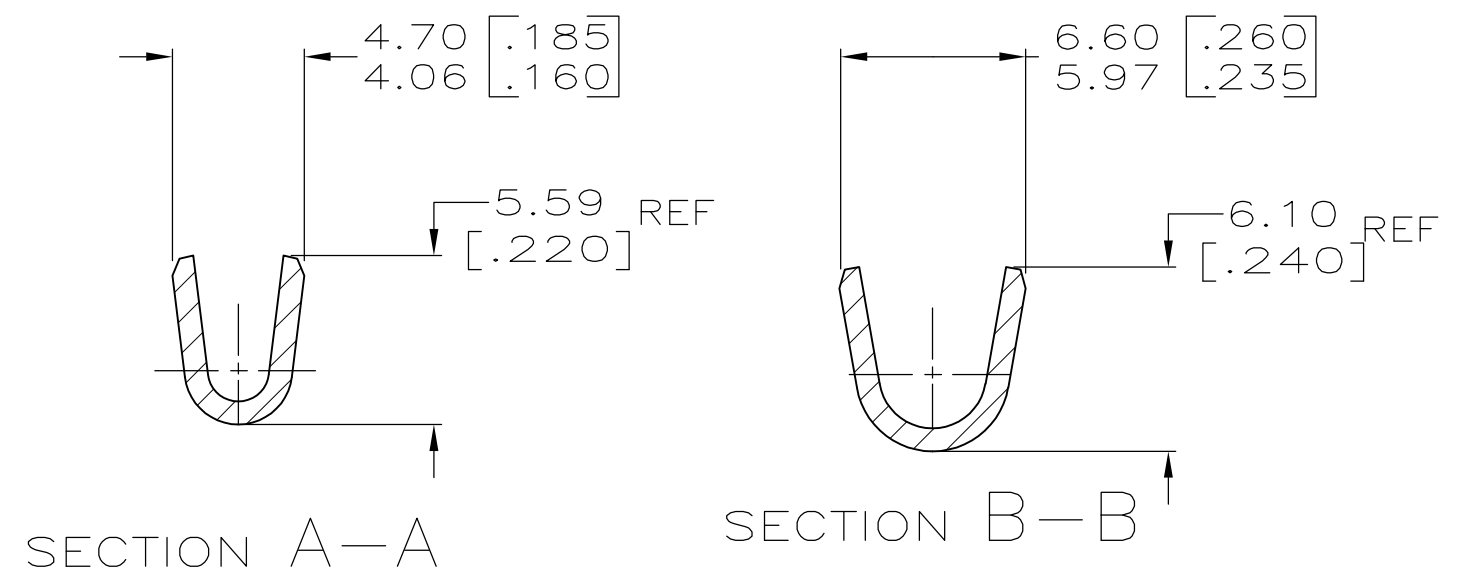
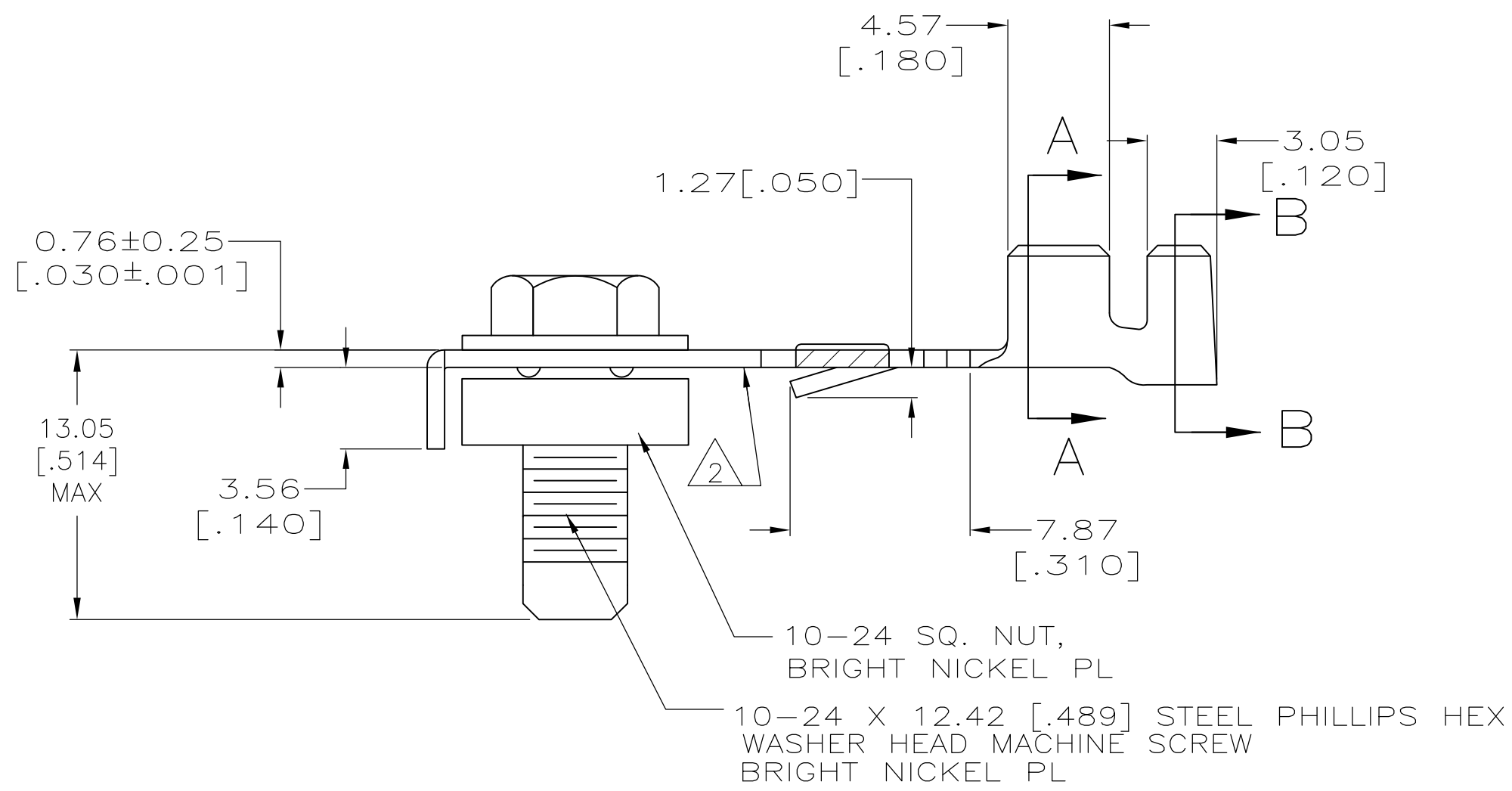

2.79-4.06 [.110-.160] DIA	#16-#12 AWG	521843-1
INSULATION RANGE	WIRE RANGE	PART NUMBER

THIS DRAWING IS A CONTROLLED DOCUMENT.		DWN JR RUTH 13SEP05	<b>TE</b> TE Connectivity		
DIMENSIONS: mm [INCHES]		CHK DONALD DECKER 13SEP05			
TOLERANCES UNLESS OTHERWISE SPECIFIED:		APVD DONALD DECKER 13SEP05	NAME TERMINAL, SUB-ASSEMBLY, POWER RING		
0 PLC ± -		PRODUCT SPEC 108-1191			
1 PLC ± -		APPLICATION SPEC 114-2087	SIZE A2	CAGE CODE 00779	DRAWING NO C=521843
2 PLC ± 0.38[.015]		WEIGHT 0.000000	SCALE 4:1	SHEET 1 OF 1	REV B2
3 PLC ± -		CUSTOMER DRAWING			
4 PLC ± -					
ANGLES ± -					
FINISH SEE COMPONENT					
MATERIAL SEE COMPONENT					