

Spec.No. KSD-523-0026-02

APPROVAL SHEET

(KYOCERA CORPORATION SAW FILTER SPECIFICATION)

Part No.: SF25-1960M5UB01

21th.Aug.'01

KYOCERA CORPORATION

Approved

Prepared

Eizo Ohtsuka

Kazuhiro Otsuka

1.Scope

This specification shall cover the characteristics of the RF SAW filter for PCS.

2.Customer's Part No.

3.KYOCERA's Part No. : SF25-1960M5UB01

4.Electrical Characteristics

Table 1

Terminating Source Impedance: 50 ohms , Single-ended

Terminating Load Impedance: 100 ohms , Differential

Items	Frequency Range	Unit	Spec.
4-01	Center Frequency	-----	MHz 1960
4-02	Maximum Insertion Attenuation	1930 to 1990MHz	dB 4.1 max.
4-03	Amplitude Ripple (p-p)	1930 to 1990MHz	dB 2.0 max.
4-04	Input/Output VSWR	1930 to 1990MHz	2.5 max.
4-05	Absolute Attenuation	0 to 1850MHz	dB 30 min.
		1850 to 1910MHz	dB 15 min.
		2040 to 3860MHz	dB 25 min.
		3860 to 3980MHz	dB 20 min.
		39800 to 6000MHz	dB 15 min.
4-06	Amplitude Imbalance: -1.0dB min. / +1.0dB max.		
4-07	Phase Imbalance: -15deg. min. / +15deg. Max.		
4-08	Operating Temperature: -30 to +85 deg.C		
4-09	Storage Temperature: -40 to +85 deg.C		

5.Measurement Condition

Set the temperature at 25 deg C as room temperature,
and measure it within the operating temperature range.

6.Measurement Circuit

- (3): Input
- (1), (5): Differential Output
- (2), (4): Ground

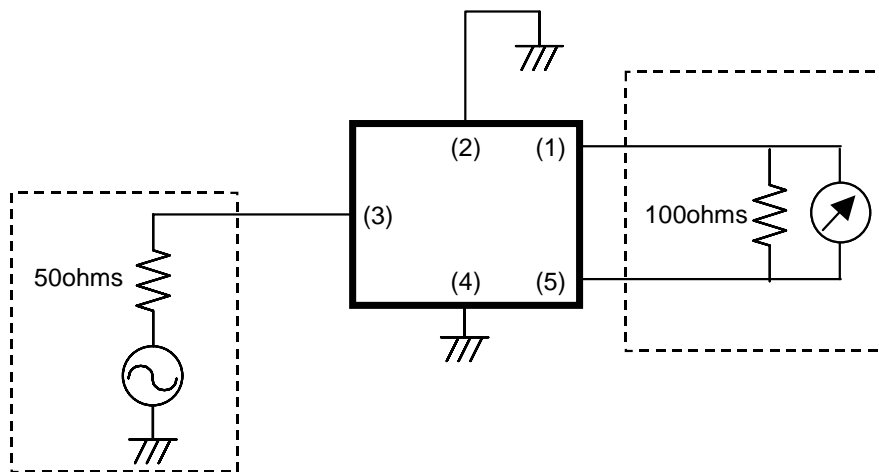

7.Dimension

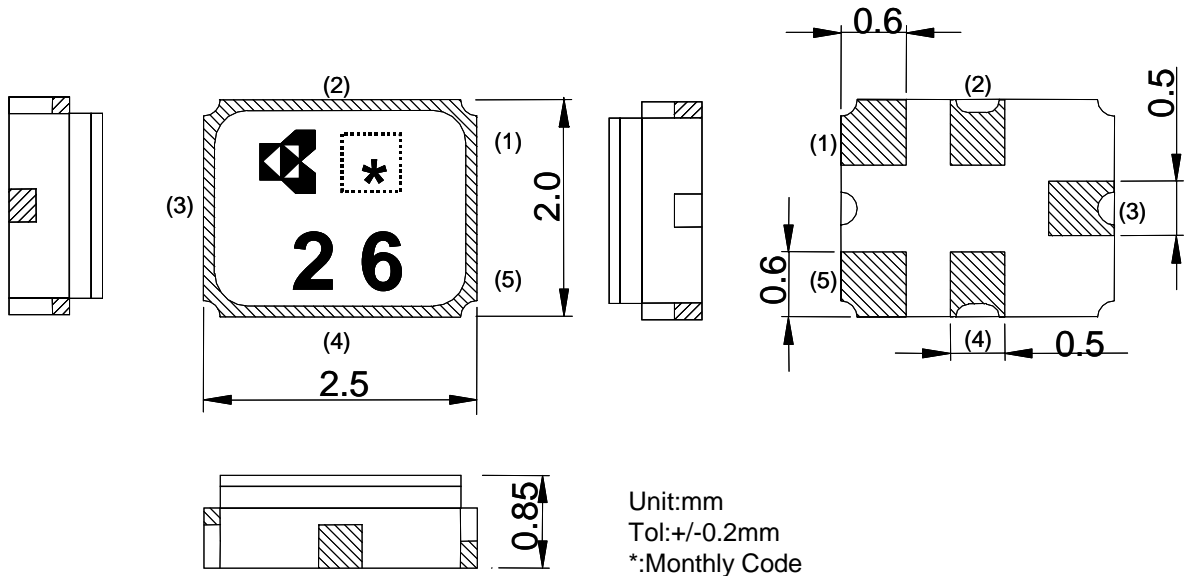

- * : MONTHLY CODE
- (1) : OUTPUT
- (2) : GROUND
- (3) : INPPUT
- (4) : GROUND
- (5) : OUTPUT

Monthly code of production

Year	Month	Code	Year	Month	Code
2001	1	A	2003	1	a
2005	2	B	2007	2	b
	3	C		3	c
	4	D		4	d
	5	E		5	e
	6	F		6	f
	7	G		7	g
	8	H		8	h
	9	J		9	j
	10	K		10	k
	11	L		11	l
	12	M		12	m
Year	Month	Code	Year	Month	Code
2002	1	N	2004	1	n
2006	2	P	2008	2	p
	3	Q		3	q
	4	R		4	r
	5	S		5	s
	6	T		6	t
	7	U		7	u
	8	V		8	v
	9	W		9	w
	10	X		10	x
	11	Y		11	y
	12	Z		12	z

8.Recommendable Land Pattern

(Top view)

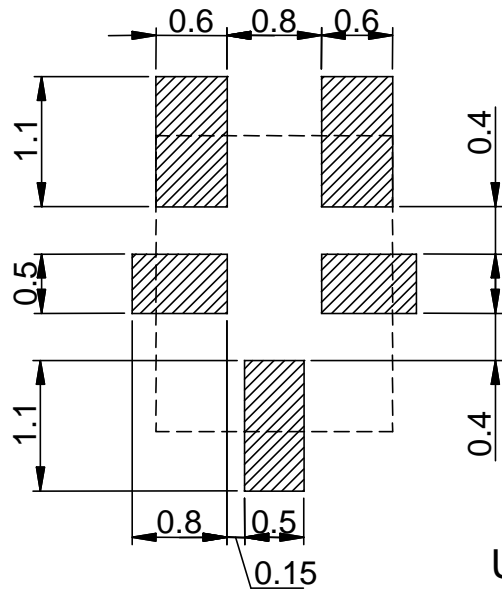

UNIT : mm
□ : Land Pattern

9.Recommendable Reflow Soldering Profile

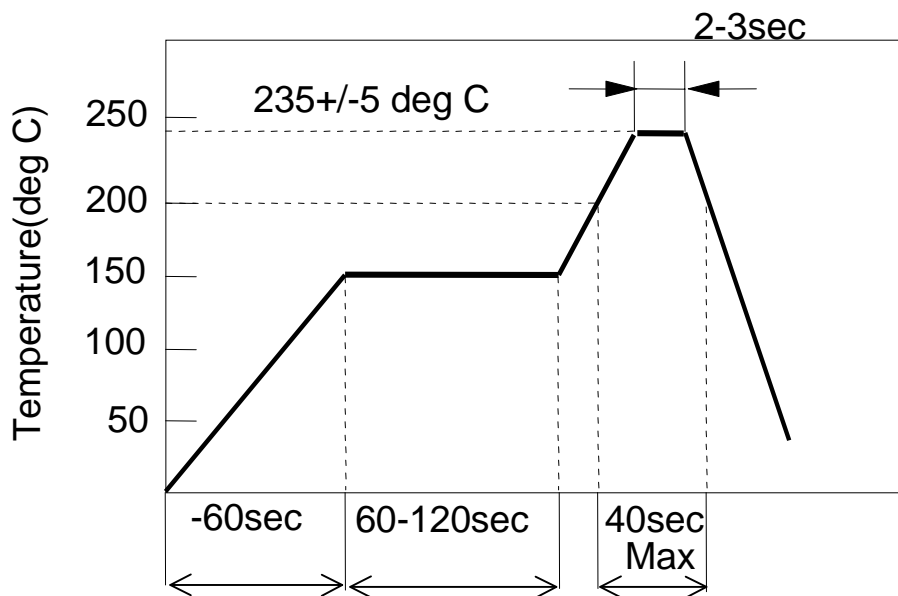

IR REFLOW SOLDERING

Temperature measurement point is surface of glass epoxy circuit board of 0.8mm thickness.

10.Environmental Characteristics

Item	Condition
Humidity	Keep the filter at 40+/-2 deg C and 90%RH to 95%RH for 500 hours. Then, release the filter into the room conditions for 2 hours minimum to the measurement. It shall fulfill the specifications in Table 1.
High Temperature Storage	Subject the filter to 85+/-5 deg C for 500 Hours. Then, release the filter into the room conditions for 2 hours minimum to the measurement. It shall fulfill the specifications in Table 1.
Low Temperature Storage	Subject the filter to -40+/-5 deg C for 500Hours. then, release the filter into the room conditions for 2 hours minimum to the measurement. It shall fulfill the specifications in Table 1.
Resistance to Reflow Solder Heat	Expose filter to increasing temperature with a minimum total exposure above 200 deg C of 40 seconds and must include 2-3 seconds at peak temperature of 235+/-5 deg C, twice. then, release the filter into the room conditions for 2 hours minimum to the measurement. It shall fulfill the specifications in Table 1.
Temperature Cycle	5 Cycles (1 cycles:-20 deg C for 0.5 hours then 60 deg C for 0.5 hours.) then, release the filter into the room conditions for 2 hours minimum to the measurement. It shall fulfill the specifications in Table 1.
Vibration	Subject the filter to vibration for 2hour each In the X,Y and Z axes with the amplitude of 1.5mm, 10 to 55 Hz/min. It shall fulfill the specifications in Table 1.
Mechanical Shock1	Subject the filter to 3 shocks in each direction Of six mutually perpendicular planes (a total of 18 shocks). Each shock shall be a sine wave shaped with a magnitude of 100 G and a duration of 6 m seconds. It shall fulfill the specifications in Table 1.
Mechanical Shock2	Drop the filter randomly onto a concrete floor from the Height of 1m, 3 times. It shall fulfill the specifications in Table 1.

11.Taping Specification

11-1.Tape Dimensions

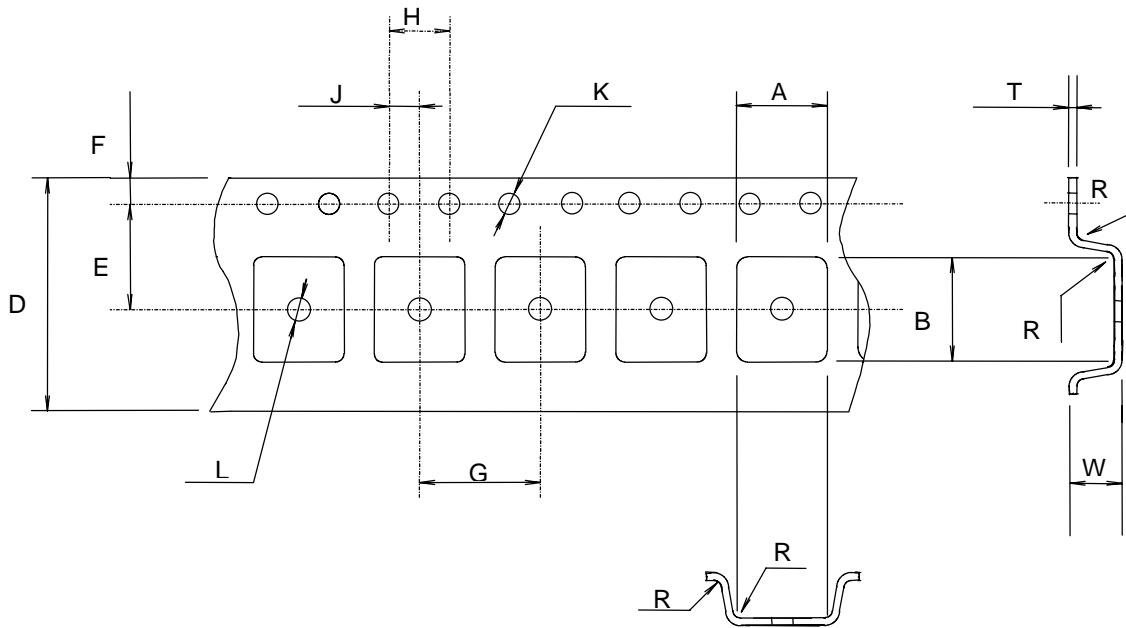

	A	B	D	E	F
Dimensions	2.4+/-0.1	2.9+/-0.1	12.0+/-0.2	5.5+/-0.05	1.75+/-0.1
	G	H	J	K	L
Dimensions	4.0+/-0.1	4.0+/-0.1	2.0+/-0.05	1.5+0.1/-0.0	1.1+/-0.1
	R	W	T		
Dimensions	0.3 MAX	1.2+/-0.1	0.3+/-0.05		

(UNIT:mm)

11-2 Taping

11-2-1 Taping Quantity

One reel of tape shall pack 3,000 filters maximum.
No filter shall be missing and contained continuously in pocket.

11-2-2 Reel Dimensions

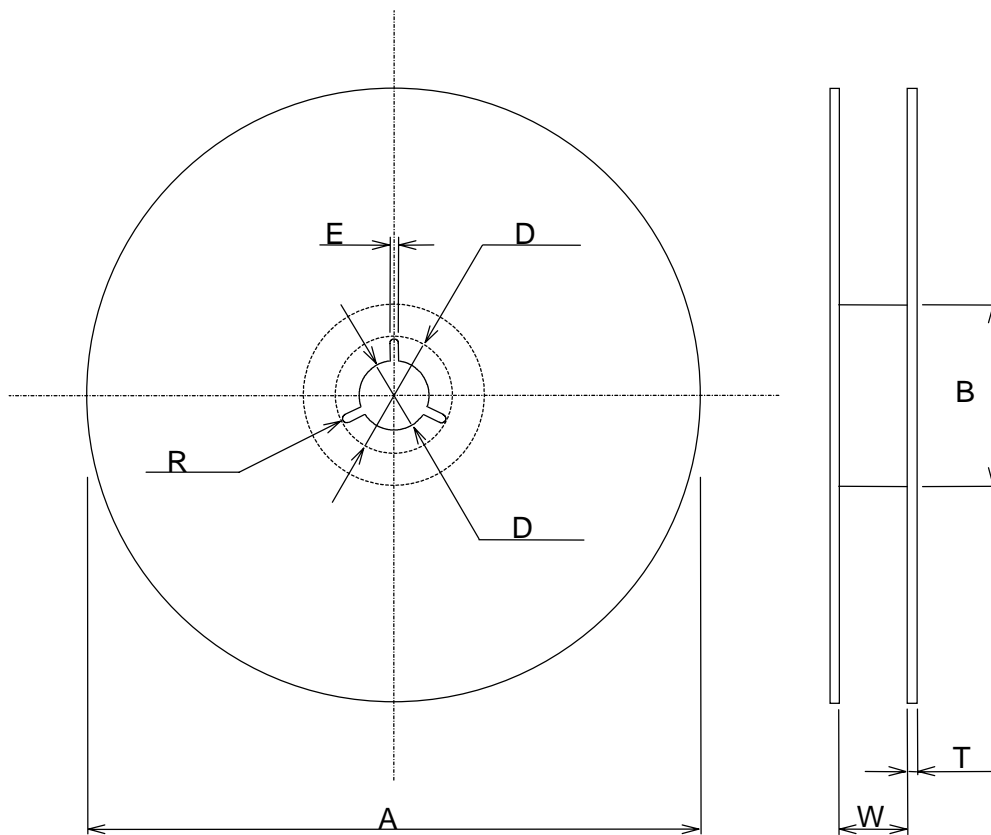

	A	B	C	D
Dimensions	330+/-2	80+/-2	13+/-0.2	21+/-0.8
	E	R	W	T
Dimensions	2+/-0.5	1	13.5+/-1	2.0+/-0.2

(UNIT : mm)

11-2-3 Leader and Blank Pocket

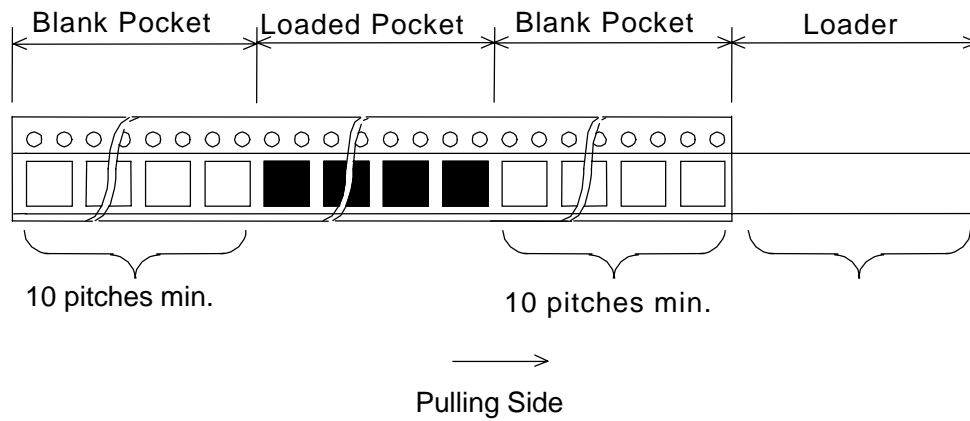

Parts Direction



11-2-4 Reel Label

Reel label shall be written the followings.

- Parts name
- Lot number
- Quantity
- Shipping date

11-2-5 Case Label

Case label shall be written the followings.

- Parts name
- Lot number
- Quantity
- Shipping date

12. Precautions in Handling

Static electricity may cause damage.

Care should be taken that such charges are not present in the vicinity.