



Keywords: automotive, power control, infotainment, body electronics, engine control, power train, ISO 9000, TS 16949

APPLICATION NOTE 5346

POWER CONTROL FOR AUTOMOTIVE APPLICATIONS

By: Masayuki Nakagawa

Abstract: This article discusses the requirements and design considerations for automotive applications, including those for engine control, infotainment, and body electronics. It also discusses several Maxim devices that are ideal for automotive power applications.

Introduction

Maxim Integrated's analog and mixed-signal ICs have been widely accepted and acclaimed in the car electronics market. This is because many of the digital arithmetic processing technologies introduced to navigation units, high-speed communications systems, and sensing units make use of large-capacity, high-speed processing.

To maintain strict quality standards required of on-board products, Maxim has upgraded ISO 9000 certification to the automobile standard TS 16949, complies with AECQ-100 to ensure the reliability of each device, and, at the same time, performs tests requested by each user. This article describes products intended for car electronics.

3A Output Step-Down DC-DC Converter with a Built-In FET

Modern car electronics require highly efficient power ICs because the vehicles are often equipped with a low-voltage, large-capacity core device. Since power ICs are mounted in radio units, it is important for ICs to operate in synchronization with the radio unit's frequency so that the switching frequency will not affect radios, TVs, GPSs, and other devices.

The [MAX2003](#) is a current-mode fully-synchronous single-output step-down converter with a low quiescent of 15 μ A at no load. MAX2003 is able to support a 45V load dump and utilizes a 45V process to ensure the reliability of onboard units (**Figure 1**). It is compatible with an input voltage range from 3.5V to 36V and capable of outputting a voltage of 1V to 10V.

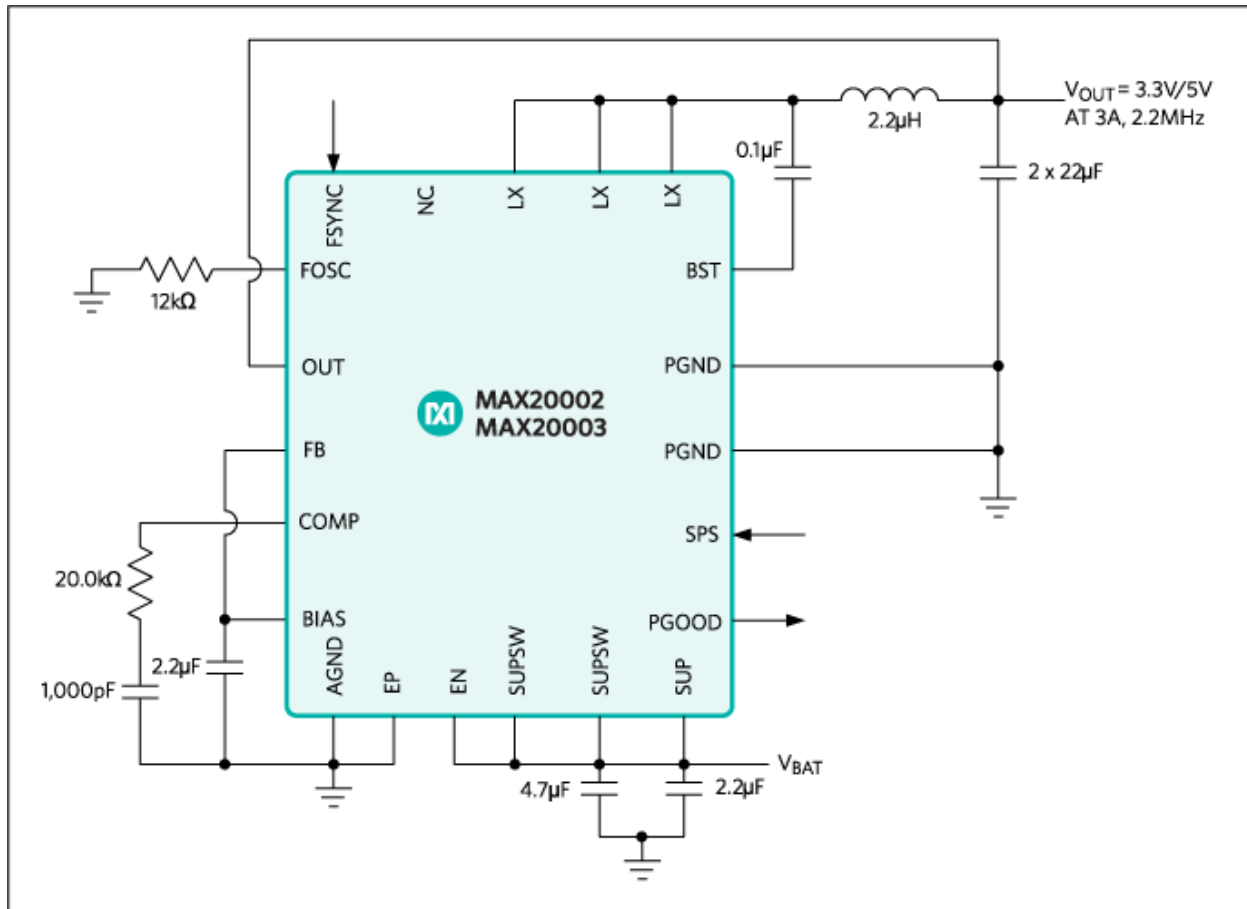

Figure 1. Application circuit of the MAX20003 step-down converter.

Recently, there have been strong demands for high efficiency under a light load, and switching loss reduced by skip mode. The MAX20003 operates in skip mode for reduced current consumption in light-load applications and supplies internal drive power from the output voltage. Thus, the device achieves an efficiency level of higher than 83% even under the conditions of an input voltage of 14V, an output voltage of 3.3V, and an output current of 10mA.

The MAX20003 switching frequency can be programmed using a resistor to ground on the FOSC pin from 220kHz to 2.2MHz. The 2.2MHz operation allows the MAX20003 to cover switching in excess of the AM radio frequency range, enabling EMI mitigation. The MAX20003 is available in a small 5mmx5mm 20-pin TQFN package with exposed pad and uses very few external components.

LDO with a Built-In Current-Sensing Amplifier and Switch for Remote Antenna

In the field of car electronics, a wide variety of radio units, including radios, digital TVs, and GPSs, are mounted in automobiles. In addition, a unit designed to convert radio signals into electric signals, an antenna unit, is frequently installed separately from the main system. In this case, it is necessary to monitor both on-board problems and the current consumed by the unit in the remote state, and communicate them to the main system.

The MAX16946 is a device developed to support automotive remote module power applications (Figure 2). The basic principle of operation of this device is that the voltage of the onboard battery is converted into any given voltage between 3.3V and 15V by a linear regulator system; this consumed current is detected by a current-sensing amplifier (CSA), and the output as an analog signal.

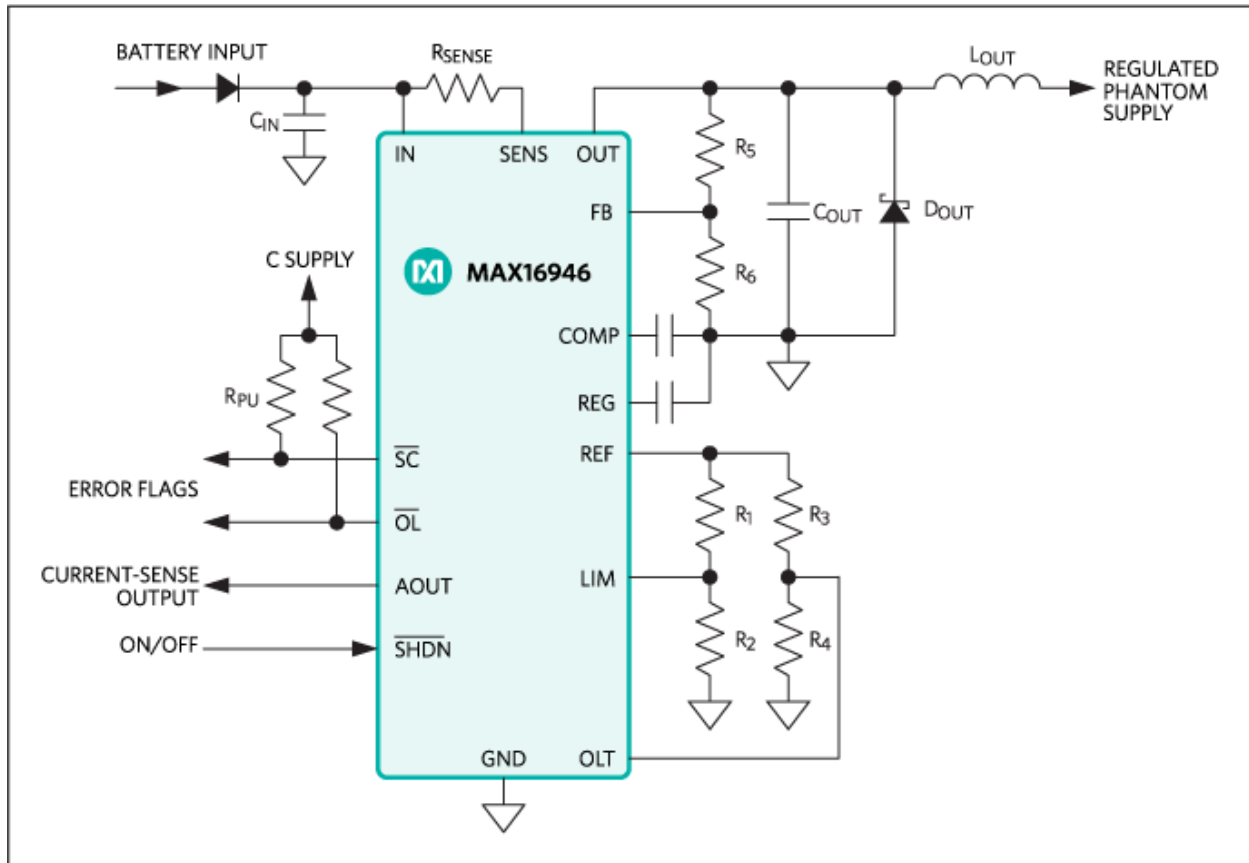

Figure 2. Application circuit of the MAX16946.

If the output detects a short circuit, earth fault, overcurrent, removal of load (detection of wire breakage), or another problem, each warning is communicated by a flag signal. The output-current capacity is 500mA at 85°C and will be protected by a thermal-shutdown function in the worst case.

Additionally, the dual-output MAX16948 is compatible with multiple power supplies. This product serves this application with the aid of a linear regulator system, but Maxim is considering a switching system in anticipation of growing demands for energy saving.

HB LED Driver with a Built-In High-Voltage CSA

Recently, the number of automobiles equipped with high-intensity LEDs for headlamps has increased. This is mainly because LEDs are superior to halogen and high-intensity discharge (HID) lamps, in that LEDs combine high efficiency, increased longevity, and distinguished design aesthetics. However, LED lamps required for car electronics need advanced analog technology because their intensity must be controlled at a constant level even in the wide voltage range of the on-board battery.

The MAX16833 drives high-intensity LEDs with a constant current and contains a high-side CSA. The switching FET is driven by detection by this sensing amplifier, so that the intensity of the LEDs connected in series can be maintained at a constant level. In addition, duty control (control that turns the LED current on and off) is used for the dimming of the LEDs, and a terminal for driving an FET other than the switching FET is provided.

The MAX16833 also supports three control systems, namely boost, SEPIC, and buck-boost. When the number of LEDs connected in series is large and the drop voltage of the LEDs is higher than the maximum value of the input voltage, only boost is applicable. When the drop voltage of the LEDs is within the maximum and minimum values of the input voltage and boost cannot provide proper control, SEPIC or buck-boost is also available.

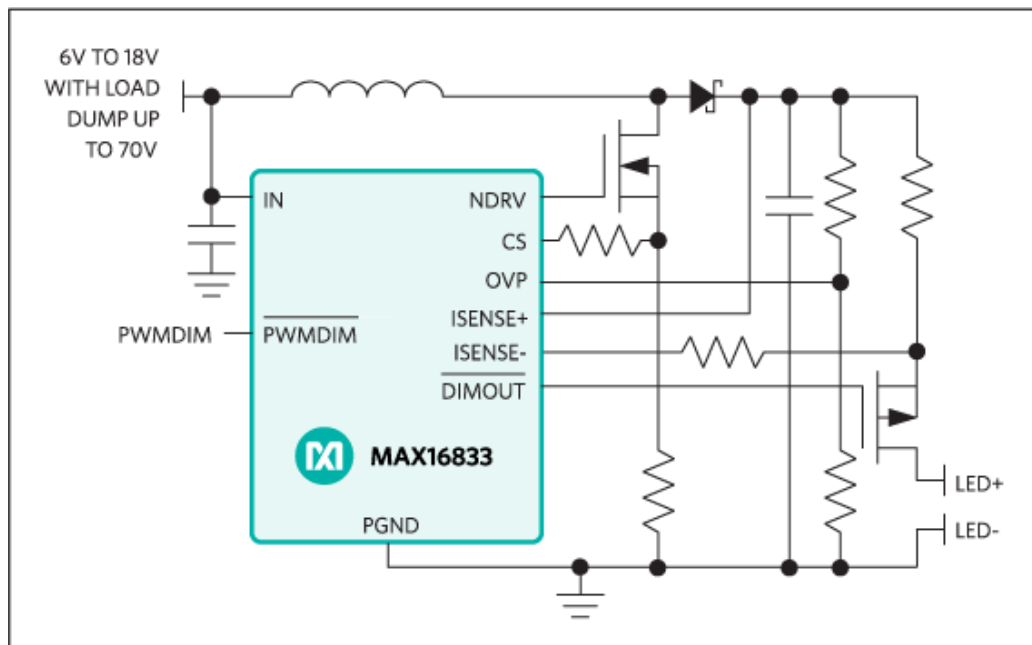

Figure 3. Application circuit of the MAX16833.

Conclusion

Maxim is constantly committed to the development of new products tailored to applications in the fragmented fields of infotainment, body electronics safety/security, and engine control and powertrain. This application note describes some of Maxim's devices for on-board automobile applications in the field of car electronics. We also develop new products, such as interfaces, battery monitors, and RF amplifiers.

| Related Parts | | |
|--------------------------|--|------------------------------|
| MAX16833 | High-Voltage HB LED Drivers with Integrated High-Side Current Sense | Free Samples |
| MAX16935 | 36V, 3.5A, 2.2MHz Step-Down Converters with 28µA Quiescent Current | Free Samples |
| MAX16936 | 36V, 220kHz to 2.2MHz Step-Down Converters with 28µA Quiescent Current | Free Samples |
| MAX16946 | Remote Antenna, Current-Sense and LDO/Switches | Free Samples |
| MAX16948 | Automotive Dual Remote Antenna Current-Sense LDO/Switch | |
| MAX20002 | 36V, 220kHz to 2.2MHz, 2A/3A Fully Integrated Step-Down Converters with 15µA Operating Current | Free Samples |

More Information

For Technical Support: <https://www.maximintegrated.com/en/support>

For Samples: <https://www.maximintegrated.com/en/samples>

Other Questions and Comments: <https://www.maximintegrated.com/en/contact>

Application Note 5346: <https://www.maximintegrated.com/en/an5346>

APPLICATION NOTE 5346, AN5346, AN 5346, APP5346, Appnote5346, Appnote 5346

© 2014 Maxim Integrated Products, Inc.

The content on this webpage is protected by copyright laws of the United States and of foreign countries. For requests to copy this content, [contact us](#).

Additional Legal Notices: <https://www.maximintegrated.com/en/legal>