

# SBPSUSL45



## Carpark Sensor



### Benefits

- **2-in-1** : sensor and RGB LED Indicator in one unit
- **Easy and fast** installation
- Automatic temperature **compensation**
- Clearly visible LED indication in a **360° visual angle**
- Select between **8 LED colours** to indicate for instance "vacant", "occupied", "booked", "disabled people"
- **Straightforward commissioning**: programming and test by using the configuration software

### Description

The ultrasonic sensor is part of the Dupline® Carpark system, which contains other variants of sensors, controllers and displays.

The SBPSUSL45 sensor is installed at the lane side pointing at the carpark bay at an angle of 45 degrees and detects cars parked in the bay.

The parking bay status is indicated by the built-in high-bright RGB LEDs, clearly visible in a 360° visual angle.

The LED colours to use for status indication are freely configurable, and they can be changed in daily operation through the UWP 3.0 configuration software. Typically, green is used for "vacant", red is used for "occupied", blue is used for "disabled people" and amber is used for "booked".

Each sensor needs to be connected to the Dupline® 3-wire bus.

The bus provides power and enables the sensors to transmit the status to the carpark controller UWP 3.0 / SBP2CPY24, which keep track of the number of available parking spaces in an area and shows the result on the connected displays.

### Applications

Parking Guidance Systems

**Main functions**

- Presence detections of cars in indoor parking space with coloured LED indication of space status.

**Structure**

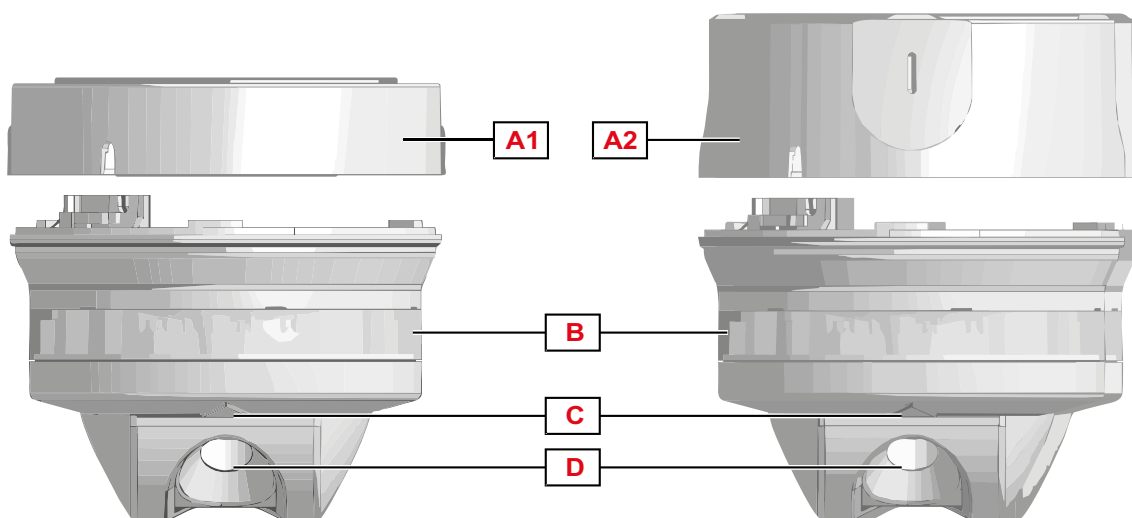

Element	Component	Function	
A1 / A2	Carpark base holder. The available versions are:		
	<b>Element</b>	<b>Code</b>	<b>Function</b>
	A1	SBPBASEA	Small base for cable tray and conduit/pipe mounting
A2	SBPBASEB	Tall base for ceiling mounting	
	<b>NOTE: The sensor is delivered without a base. Please order SBPBASEA or SBPBASEB separately</b>		
B	High-bright RBG LEDs with a 360° visual angle	The LED colours indicate the parking bay status for the drivers	
C	Local calibration button	This can be used to perform the sensor calibration by pressing it locally	
D	Ultrasonic sensor with 45 degrees detection angle	This detects the parking bay occupied status by using 40 kHz ultrasonic waves	

## Features

### General

<b>Material</b>	ABS	
<b>LED protection</b>	Transparent polycarbonate	
<b>Housing colour</b>	Light grey	
<b>Dimensions</b>	Base SBPBASEA + Sensor	103.5 x 116 mm
	Base SBPBASEB + Sensor	122 x 116 mm
<b>Weight</b>	Base SBPBASEA + Sensor	275 g
	Base SBPBASEB + Sensor	300 g
<b>RJ12 connector</b>	Female: in base Male: with cable in sensor	Internal communication between sensor and base

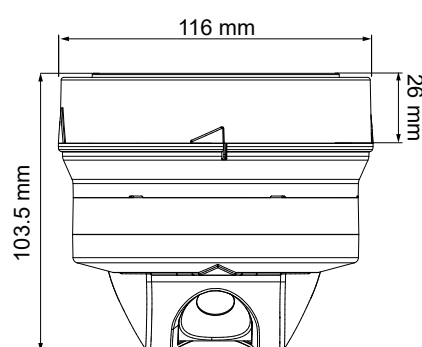

Fig. 1 Rail mounting - base A + Sensor

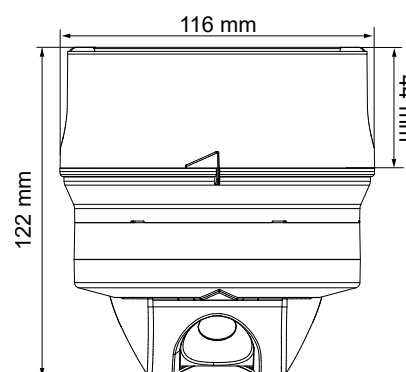

Fig. 2 Ceiling mounting - base B + Sensor

### Environmental

<b>Operating temperature</b>	-40 to 70°C (-40 to 158°F)
<b>Storage temperature</b>	-40 to 80°C (-40 to 176°F)
<b>Degree of protection</b>	IP34 The circuit board is treated to be protected against fumes and fine dust. The sensor is protected against water dripping from the ceiling.
<b>Humidity</b>	5-98% Relative humidity
<b>Pollution degree</b>	3 (IEC60664)

### Compatibility and conformity

<b>CE-marking</b>	
<b>Approvals</b>	

**Power Supply**

<b>Power supply</b>	By the Dupline® bus via the RJ12 connector; POW 20-28 Vdc
<b>Current consumption</b>	1 mA on the Dupline® bus; 27 mA on POW

**Sensor**

<b>Technology</b>	40 kHz ultrasonic element
<b>Max. distance between sensor and floor</b>	Between 2.2 m and 2.4 m
<b>Vertical mounting deviation</b>	±5 degree max
<b>Horizontal mounting deviation</b>	±2 degree max
<b>Total time response from sensor to UWP 3.0</b>	4.0 s @ 8 measures filter
<b>MTBF</b>	70,000 hours
<b>Temperature compensation</b>	The built-in temperature compensation makes the sensor stable and reliable

**Communication**

<b>Protocol</b>	Smart-Dupline®
-----------------	----------------

## Connection Diagrams

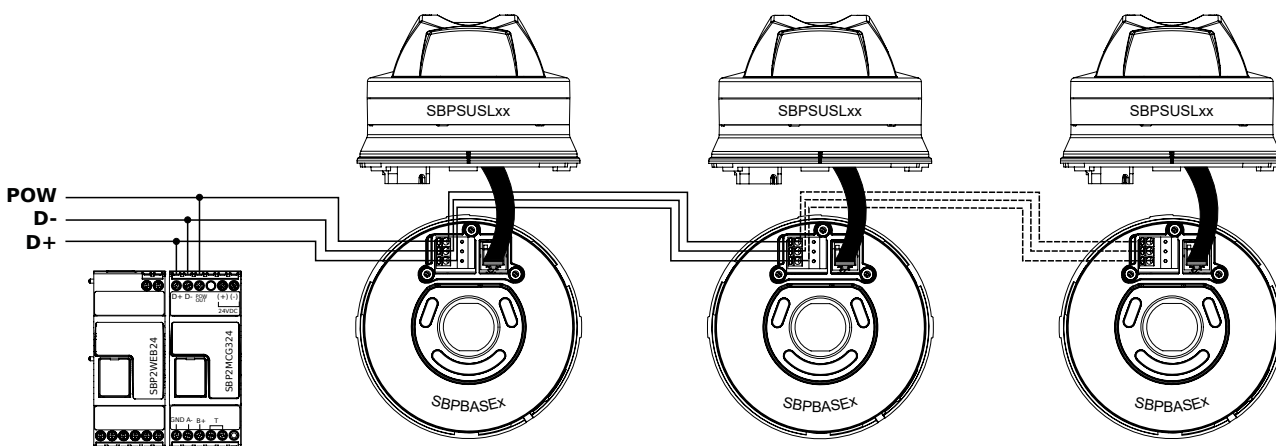

## Mode of operation

### Installation

The sensor should be placed at a height between 2.2 to 2.4m.  
The depth of detection is 1.5 m.

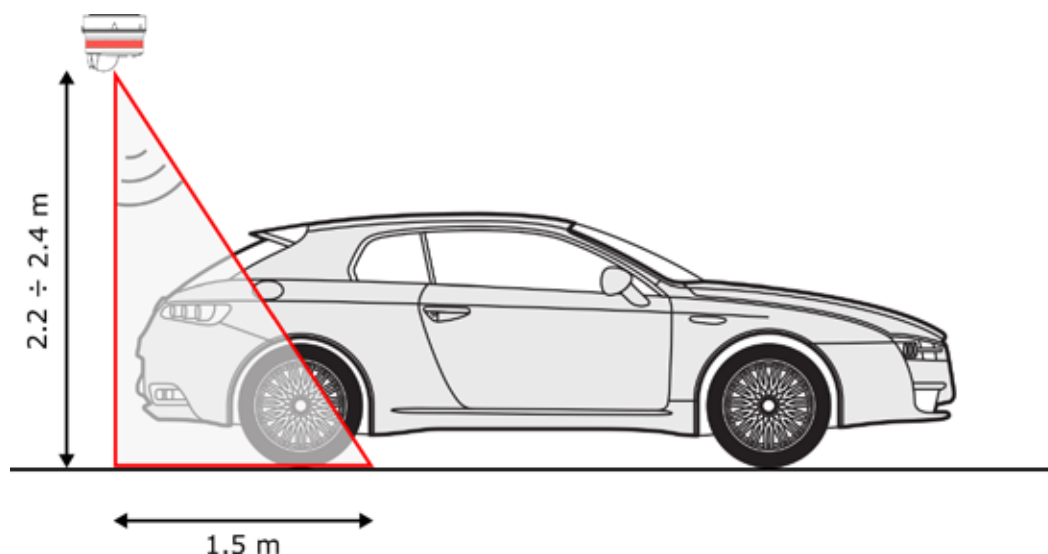

Fig. 3 Sensor height and distance

The following mounting suggestions are the standard ones; for any type of application other than those shown below, please contact our technical assistance before installing the SBPSUSL45 and the SBPBASEx.

#### Example 1

In this example the sensor is clearly visible for the drivers even if it is positioned more inside the parking bay, without renouncing the visibility. The detection capability of the sensor greatly increases, bringing the sensor closer to the parking bay: the detection range is 1.5 m.



The sensor is too far from the parking bay



Put the sensor as close as possible to the parking bay





### Example 2

In this example the sensor could have been installed closer to the parking bay: it should be mounted on the right hand of the cable tray

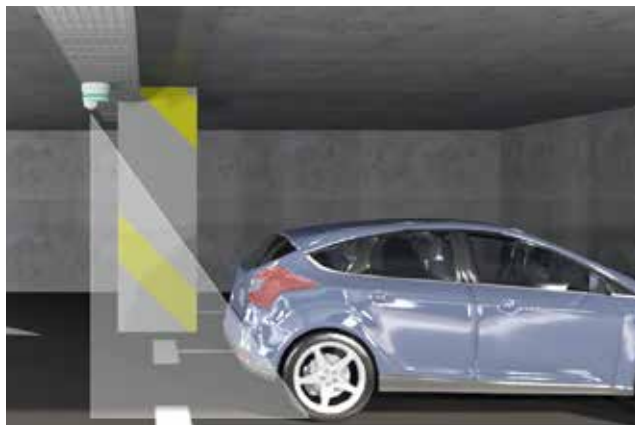

The sensor is wrongly mounted on the left hand of the cable tray



Put the sensor on the right hand of the cable tray



### Obstacles

The sensor must not be installed where it can encounter obstacles on the ceiling.

The obstacles on the ceiling (pipes, beams, lamps, fans and ducts) that can obstruct the sensor, must be at a minimum distance of 2.5 m (if they are at the same height of the sensor) and they must have a maximum height/thickness of 30 cm. (see figure below).

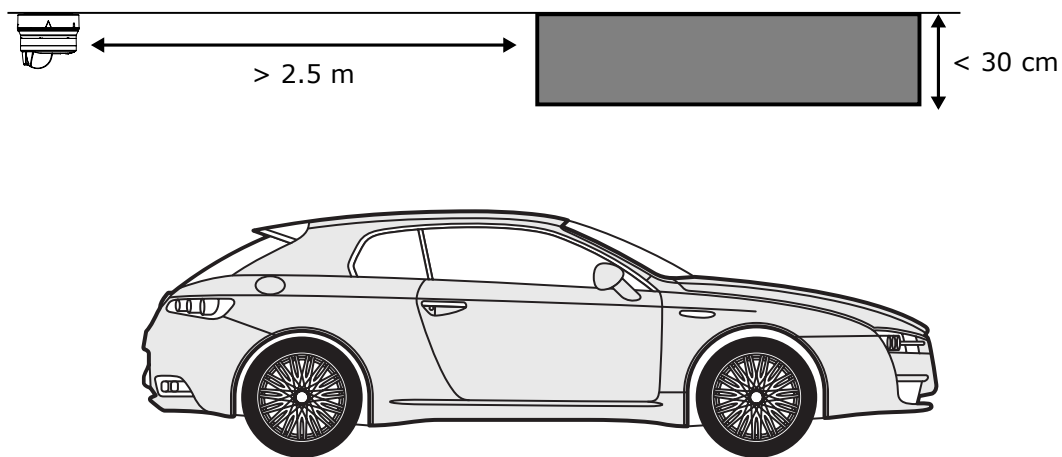

Fig. 4 The obstacles decrease the detection capability of the sensor

**Example 3**

In this example the LED lamp is too close to the sensor and wrongly mounted in front of the sensor, obstructing the visibility.



The LED lamp is wrongly mounted in front of the sensor



Put the sensor in front of the LED lamp



If the distance between the obstacle and the sensor is less than 2.5 m, the base of the sensor must be installed at least 5 cm below the obstacle.

**Note: The SBPBASEA base has to be used for conduit/pipe mounting**

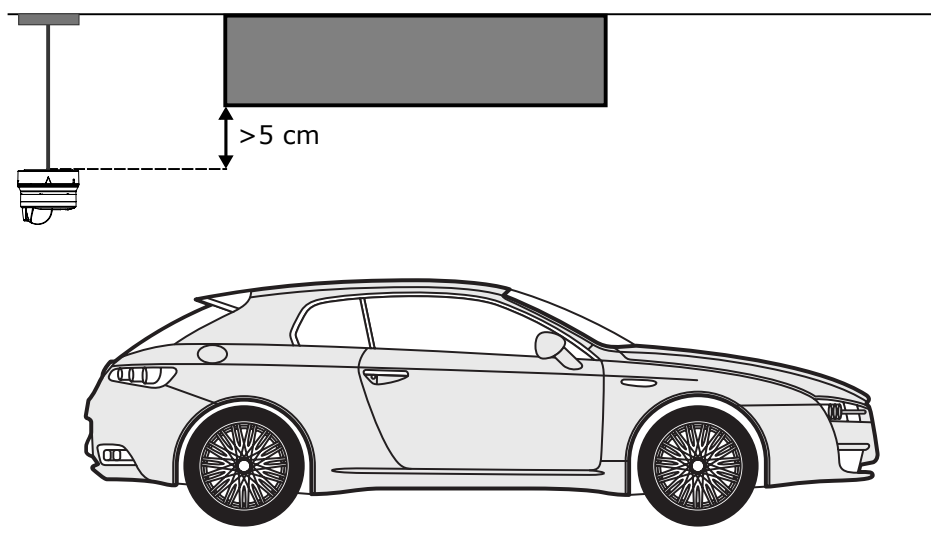

**Fig. 5** The base of the sensor must be at least 5 cm below the obstacle

**Example 4**

In this example the ventilation fan is lower than the sensor. The SBPBASEB (left picture) has to be replaced with SBPBASEA for conduit/pipe mounting.

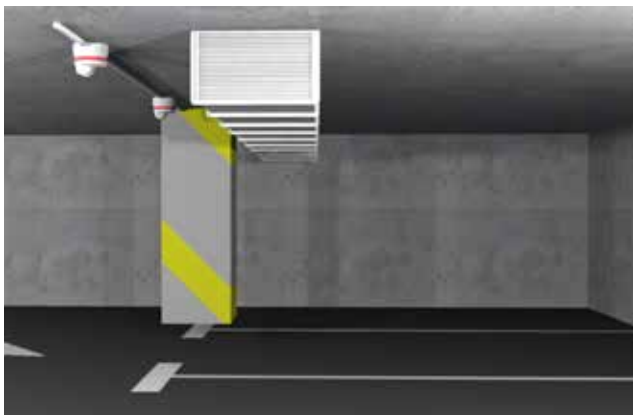

The sensor is obstructed by the obstacle

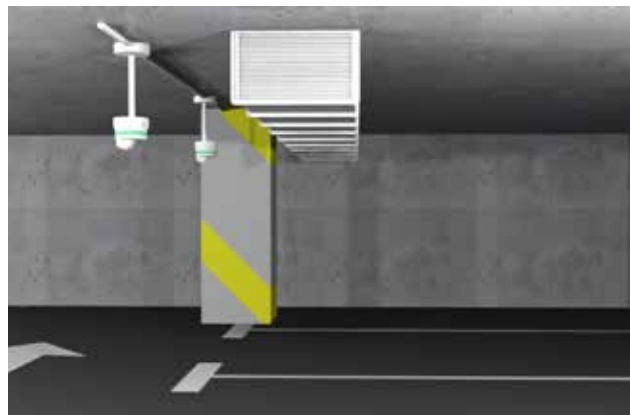

Put the SBPBASEA at least 5 cm below the obstacle

**Example 5**

In this example the obstacle (beam) is lower than the sensor and it is too close ( $< 2.5$  m).



The sensor is obstructed by the obstacle

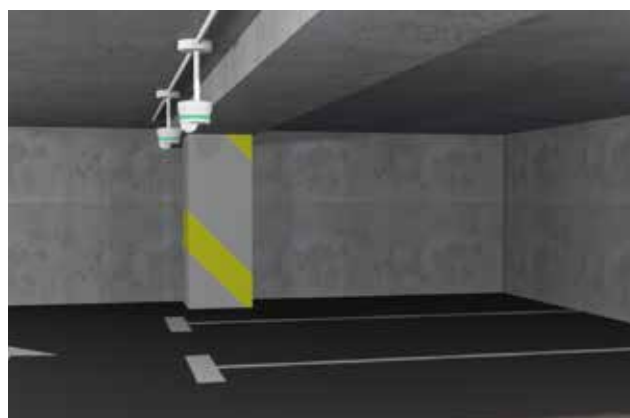

Put the SBPBASEA at least 5 cm below the obstacle







### Lateral obstacles

The same considerations above-mentioned have to be applied if the obstacle is on the side part of the sensor: in this case, the minimum distance between the lateral obstacle and the sensor must be at least 1 m. If they are at the same height of the sensor, they must have a maximum thickness of 30 cm.

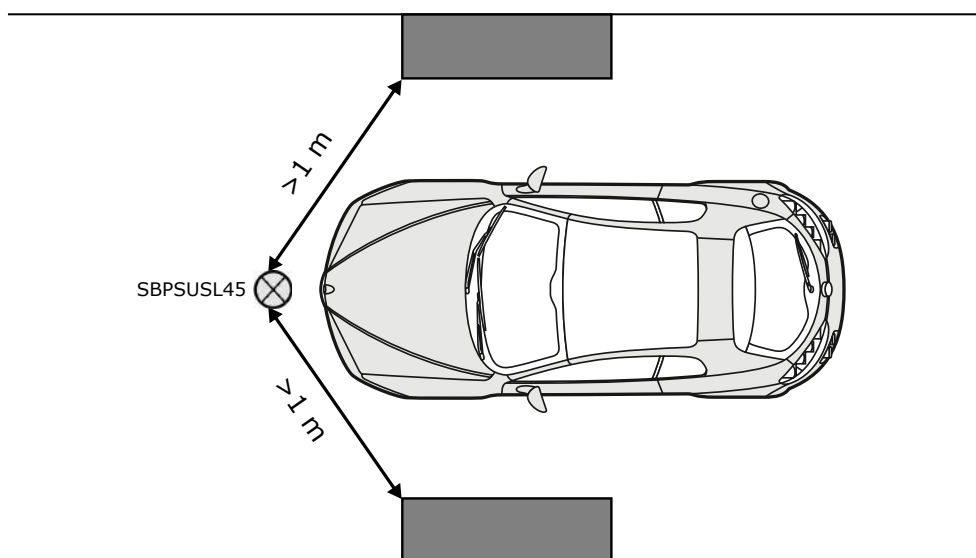

**Fig. 6** The lateral obstacle must be at a minimum distance of 1 m from the sensor

### Example 6

In this example the obstacle is on the side part of the sensor and the distance between them is less than 1 m. Moreover, the thickness of the obstacle is more than 30 cm. The SBPBASEA for conduit/pipe mounting has to be installed to mount the sensor at least 5 cm below the obstacles.

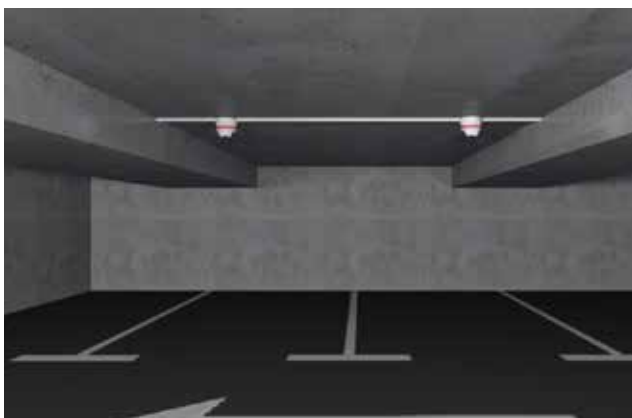

The obstacle is too close to the sensors

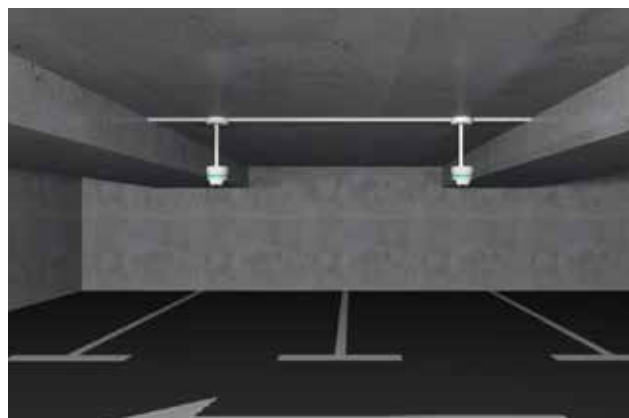

Put the SBPBASEA at least 5 cm below the obstacles



**Increase reliability**

To stop the vehicles at the parking bay area, especially for parking bays that are depth over 5 m, the **wheel-stoppers** are suggested.



The vehicle has been parked too far from the sensor



Wheel-stoppers avoid to park too far from the sensor



To increase reliability, it is mandatory to install the sensors when the lines on the parking lot have already been painted.

### SBPBASEx mounting

The sensor must be mounted on either base holder SBPBASEA (cable tray or conduit) or base holder SBPBASEB (ceiling mount).

Place the sensor with the vertical mark at the tip of the triangle base.

Turn the sensor clockwise until the vertical mark is positioned at the rear end of the triangle. The sensor is now attached to the base.

Release the sensor by turning it anti-clockwise.

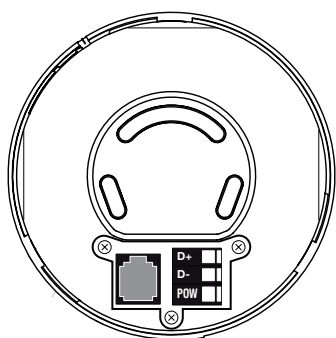

**Fig. 7** Basepart: mounted on the ceiling

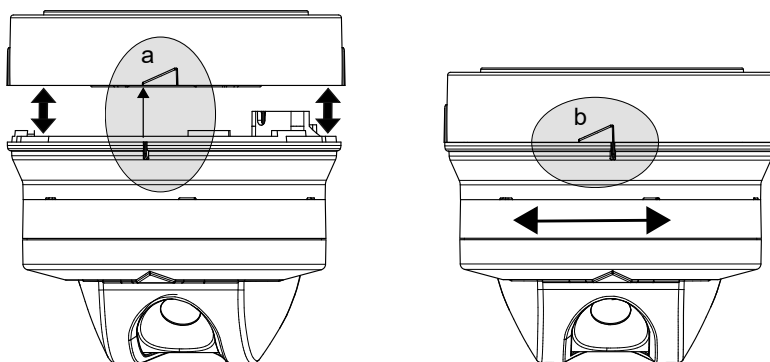

**Fig. 8** Mount / Unmount

When mounting the sensor on the ceiling or in a rail, the sensor must be installed at an angle of maximum  $\pm 5$  degrees deviation from the ceiling surface and a  $\pm 2$ -degrees' horizontal deviation to accomplish a safe and reliable signal from the sensor.

See drawing below.

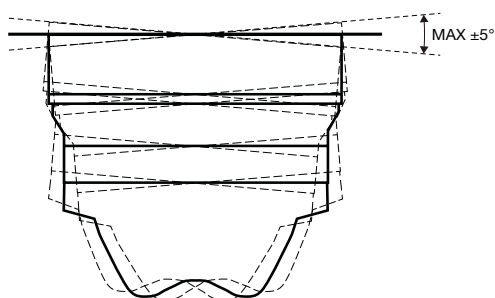

**Fig. 9** Maximum  $\pm 5^\circ$  vertical deviation

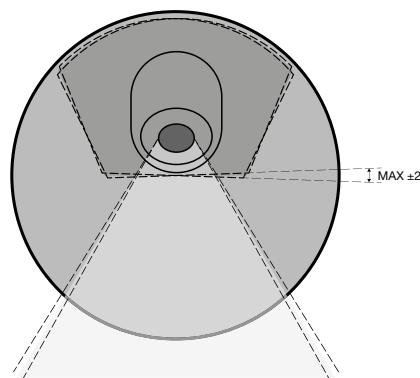

**Fig. 10** Maximum  $\pm 2^\circ$  horizontal deviation. Bottom view

Make sure that there is some extra wire for the sensor so that maintenance of the sensor/base in the future is enabled. Also place the wire correctly to avoid damage to the cable isolation.

**Configuration**

When sensor and base are mounted and connected to the Dupline® 3-wire network with power and communication, they are ready for configuration.

The UWP 3.0 configuration software automatically scans the network and finds all the sensors and other connected devices.

Once this has been done, the user assigns addresses to the sensors connected simply by walking from sensor to sensor and pressing the configuration button on the bottom.

Please refer to the UWP 3.0 Carpark software manual for further details about configuration.

The sensor emits an ultrasonic signal at a frequency of 40 kHz which is reflected when it hits the floor or a parked car and returned to the sensor. Depending on the shape of the received echo signal, the sensor can determine if there is a car parked or not. The calibration has to be carried out with no cars and any time structural changes are made in the parking bay.

All programming of the sensor is thoroughly described in the UWP 3.0 Carpark software manual: <http://productselection.net/searchproduct.php>

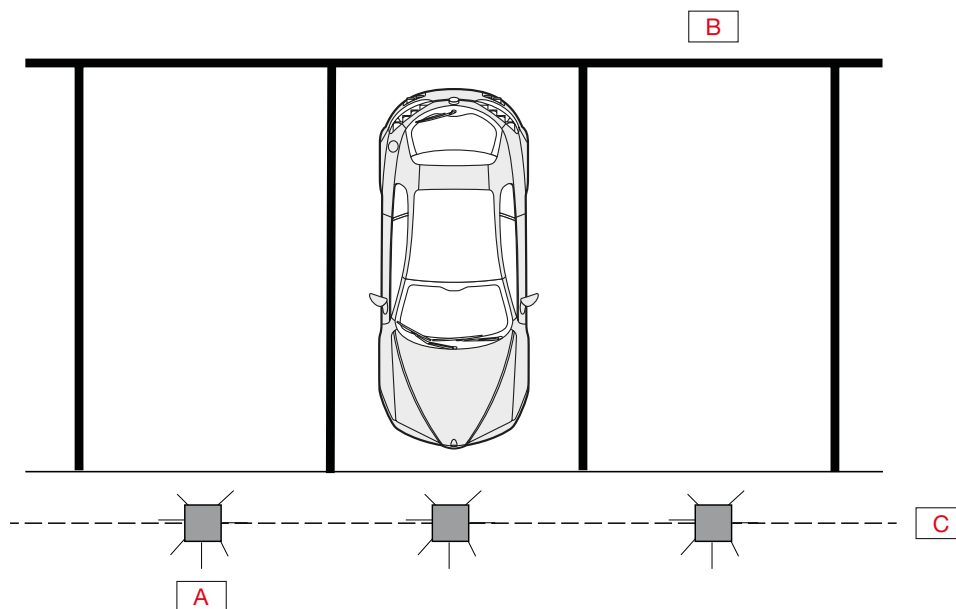

**Fig. 11 Sensor installation**

<b>A</b>	Sensor with LED	<b>C</b>	Dupline® bus
<b>B</b>	Parking spaces		

 **Sensor status and calibration**

Status	Condition	LED status	Note
<b>Normal</b>	Bay is occupied	Colour for occupied	By default, the colour is configured to be red
	Bay is vacant	Colour for vacant	By default, the colour is configured to be green
<b>Addressing procedure*</b>	Disabled	Red/green, according to the programming	Module has no address
	Enabled	Yellow, normal flash	Module is waiting for receiving a new address
	Accepted	Green, fast flash (for 3 s.)	Module has received the new address
	Assigned	Green, normal flash	Module already has an address
<b>Remote calibration</b>	In progress	Yellow, fast flash (for 15 sec)	
	Error	Red, normal flash (for 3 s.)	
	OK	Green, normal flash (for 3 s.)	
<b>Local calibration</b>	Start delay	Yellow, slow flash (for 15 s.)	
	In progress	Yellow, fast flash (for 15 s.)	
	Error	Red, normal flash (for 3 s.)	
	OK	Green, normal flash (for 3 s.)	
<b>Calibration required</b>		White, fast flash	The sensor needs to be calibrated
<b>Start-up</b>		White, flash (for 3 s.)	If it is not white, LEDs are damaged

\* Addressing procedure is described in the configuration manual.

All the LED status can be programmed by software



## References

### Further reading

Information	Document	Where to find it
Carpark installation	CP3 manual	<a href="http://www.productselection.net/MANUALS/UK/cp3_manual.pdf">www.productselection.net/MANUALS/UK/cp3_manual.pdf</a>
UWP 3.0 installation guide	System manual	<a href="http://www.productselection.net/MANUALS/UK/system_manual.pdf">www.productselection.net/MANUALS/UK/system_manual.pdf</a>
UWP 3.0 software manual	UWP 3.0 tool manual	<a href="http://www.productselection.net/MANUALS/UK/uwp3.0_tool.pdf">www.productselection.net/MANUALS/UK/uwp3.0_tool.pdf</a>
CP3 troubleshooting guide	Troubleshooting guide	<a href="http://www.productselection.net/MANUALS/UK/troubleshooting_guide.pdf">www.productselection.net/MANUALS/UK/troubleshooting_guide.pdf</a>
Installation manual	IM_SBPSUSL45	<a href="http://www.productselection.net/MANUALS/UK/IM_SBPSUSL45.pdf">www.productselection.net/MANUALS/UK/IM_SBPSUSL45.pdf</a>

### Order code



### SBPSUSL45

**Note:** The sensor is delivered without a base. Please order SBPBASEA or SBPBASEB separately.

### CARLO GAVAZZI compatible components

Purpose	Component name/code	Notes
Controller	UWP30RSEXXX	
Bus generator	SBP2MCG324	

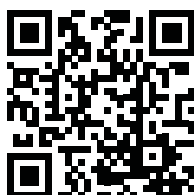

COPYRIGHT ©2016  
Content subject to change. Download the PDF: [www.productselection.net](http://www.productselection.net)